



**IAR Embedded  
Workbench**

# C-SPY® Debugging Guide

for the Texas Instruments

**MSP430 Microcontroller Family**

## **COPYRIGHT NOTICE**

© 2010-2017 IAR Systems AB.

No part of this document may be reproduced without the prior written consent of IAR Systems AB. The software described in this document is furnished under a license and may only be used or copied in accordance with the terms of such a license.

## **DISCLAIMER**

The information in this document is subject to change without notice and does not represent a commitment on any part of IAR Systems. While the information contained herein is assumed to be accurate, IAR Systems assumes no responsibility for any errors or omissions.

In no event shall IAR Systems, its employees, its contractors, or the authors of this document be liable for special, direct, indirect, or consequential damage, losses, costs, charges, claims, demands, claim for lost profits, fees, or expenses of any nature or kind.

## **TRADEMARKS**

IAR Systems, IAR Embedded Workbench, IAR Connect, C-SPY, C-RUN, C-STAT, visualSTATE, IAR KickStart Kit, IAR Experiment!, I-jet, I-jet Trace, I-scope, IAR Academy, IAR, and the logotype of IAR Systems are trademarks or registered trademarks owned by IAR Systems AB.

Microsoft and Windows are registered trademarks of Microsoft Corporation.

Texas Instruments is a registered trademark of Texas Instruments Corporation. MSP430 is a trademark of Texas Instruments Corporation.

Adobe and Acrobat Reader are registered trademarks of Adobe Systems Incorporated.

All other product names are trademarks or registered trademarks of their respective owners.

## **EDITION NOTICE**

Fifth edition: March 2017

Part number: UCS430-5

This guide applies to version 7.x of IAR Embedded Workbench® for the Texas Instruments MSP430 microcontroller family.

Internal reference: M21, Mym8.0, IMAE.

# Brief contents

Tables .....	21
Preface .....	23
<b>Part 1. Basic debugging</b> .....	<b>31</b>
The IAR C-SPY Debugger .....	33
Getting started using C-SPY .....	43
Executing your application .....	59
Variables and expressions .....	79
Breakpoints .....	103
Memory and registers .....	137
<b>Part 2. Analyzing your application</b> .....	<b>175</b>
Trace .....	177
The application timeline .....	191
Profiling .....	221
Code coverage .....	231
Power debugging .....	235
<b>Part 3. Advanced debugging</b> .....	<b>259</b>
Interrupts .....	261
The advanced cycle counter .....	283
State storage .....	291
The sequencer .....	299
C-SPY macros .....	305

The C-SPY command line utility—cspybat .....	363
<b>Part 4. Additional reference information .....</b>	<b>387</b>
Debugger options .....	389
Additional information on C-SPY drivers .....	401
Index .....	413

# Contents

Tables .....	21
Preface .....	23
<b>Who should read this guide</b> .....	23
Required knowledge .....	23
<b>How to use this guide</b> .....	23
<b>What this guide contains</b> .....	24
Part 1. Basic debugging .....	24
Part 2. Analyzing your application .....	24
Part 3. Advanced debugging .....	25
Part 4. Additional reference information .....	25
<b>Other documentation</b> .....	25
User and reference guides .....	26
The online help system .....	26
Web sites .....	27
<b>Document conventions</b> .....	27
Typographic conventions .....	27
Naming conventions .....	28
<b>Part I. Basic debugging</b> .....	31
The IAR C-SPY Debugger .....	33
<b>Introduction to C-SPY</b> .....	33
An integrated environment .....	33
General C-SPY debugger features .....	34
RTOS awareness .....	35
<b>Debugger concepts</b> .....	36
C-SPY and target systems .....	36
The debugger .....	37
The target system .....	37
The application .....	37
C-SPY debugger systems .....	37

The ROM-monitor program .....	38
Third-party debuggers .....	38
C-SPY plugin modules .....	38
<b>C-SPY drivers overview</b> .....	39
Differences between the C-SPY drivers .....	39
<b>The IAR C-SPY Simulator</b> .....	40
<b>The C-SPY hardware debugger drivers</b> .....	40
Features .....	41
Communication overview .....	41
<b>Getting started using C-SPY</b> .....	43
<b>Setting up C-SPY</b> .....	43
Setting up for debugging .....	43
Executing from reset .....	44
Using a setup macro file .....	44
Selecting a device description file .....	44
Loading plugin modules .....	45
<b>Starting C-SPY</b> .....	45
Starting a debug session .....	45
Loading executable files built outside of the IDE .....	46
Starting a debug session with source files missing .....	46
Loading multiple images .....	47
Editing in C-SPY windows .....	47
<b>Adapting for target hardware</b> .....	48
Modifying a device description file .....	48
Initializing target hardware before C-SPY starts .....	49
Using predefined C-SPY macros for device support .....	50
<b>Reference information on starting C-SPY</b> .....	50
C-SPY Debugger main window .....	50
Images window .....	54
Get Alternative File dialog box .....	55
Device Information window .....	56

Executing your application .....	59
<b>Introduction to application execution</b> .....	59
Briefly about application execution .....	59
Source and disassembly mode debugging .....	59
Single stepping .....	60
Troubleshooting slow stepping speed .....	63
Running the application .....	64
Highlighting .....	64
Viewing the call stack .....	65
Terminal input and output .....	65
Debug logging .....	65
<b>Reference information on application execution</b> .....	66
Disassembly window .....	67
Call Stack window .....	71
Terminal I/O window .....	73
Terminal I/O Log File dialog box .....	74
Debug Log window .....	75
Log File dialog box .....	77
Report Assert dialog box .....	78
Autostep settings dialog box .....	78
Variables and expressions .....	79
<b>Introduction to working with variables and expressions</b> .....	79
Briefly about working with variables and expressions .....	79
C-SPY expressions .....	80
Limitations on variable information .....	82
<b>Working with variables and expressions</b> .....	83
Using the windows related to variables and expressions .....	83
Viewing assembler variables .....	84
<b>Reference information on working with variables and expressions</b> .....	85
Auto window .....	85
Locals window .....	87
Watch window .....	89

Live Watch window .....	92
Statics window .....	94
Quick Watch window .....	97
Symbols window .....	100
Resolve Symbol Ambiguity dialog box .....	101
<b>Breakpoints .....</b>	<b>103</b>
<b>Introduction to setting and using breakpoints .....</b>	<b>103</b>
Reasons for using breakpoints .....	103
Briefly about setting breakpoints .....	103
Breakpoint types .....	104
Breakpoint icons .....	106
Breakpoints in the C-SPY simulator .....	106
Breakpoints in the C-SPY FET debugger driver .....	106
Breakpoint consumers .....	107
<b>Setting breakpoints .....</b>	<b>109</b>
Various ways to set a breakpoint .....	109
Toggling a simple code breakpoint .....	109
Setting breakpoints using the dialog box .....	109
Setting a data breakpoint in the Memory window .....	111
Setting breakpoints using system macros .....	111
Useful breakpoint hints .....	112
<b>Reference information on breakpoints .....</b>	<b>114</b>
Breakpoints window .....	115
Breakpoint Usage window .....	117
Code breakpoints dialog box .....	118
Log breakpoints dialog box .....	119
Data breakpoints dialog box .....	121
Data Log breakpoints dialog box .....	123
Immediate breakpoints dialog box .....	124
Range breakpoints dialog box .....	125
Conditional breakpoints dialog box .....	127
Advanced Trigger breakpoints dialog box .....	130
Enter Location dialog box .....	132



Breakpoint combiner dialog box .....	133
Resolve Source Ambiguity dialog box .....	134
<b>Memory and registers .....</b>	<b>137</b>
<b>Introduction to monitoring memory and registers .....</b>	<b>137</b>
Briefly about monitoring memory and registers .....	137
C-SPY memory zones .....	138
Memory configuration for the C-SPY simulator .....	139
<b>Monitoring memory and registers .....</b>	<b>140</b>
Defining application-specific register groups .....	141
Monitoring stack usage .....	142
<b>Reference information on memory and registers .....</b>	<b>144</b>
Memory window .....	145
Memory Save dialog box .....	149
Memory Restore dialog box .....	150
Fill dialog box .....	151
Symbolic Memory window .....	152
Stack window .....	155
Registers window .....	159
Register User Groups Setup window .....	162
SFR Setup window .....	164
Edit SFR dialog box .....	167
Memory Access Setup dialog box .....	169
Edit Memory Access dialog box .....	171
Memory Dump dialog box .....	172
<b>Part 2. Analyzing your application .....</b>	<b>175</b>
<b>Trace .....</b>	<b>177</b>
<b>Introduction to using trace .....</b>	<b>177</b>
Reasons for using trace .....	177
Briefly about trace .....	177
Requirements for using trace .....	178

<b>Collecting and using trace data</b> .....	178
Getting started with trace .....	178
Trace data collection using breakpoints .....	179
Searching in trace data .....	179
Browsing through trace data .....	180
<b>Reference information on trace</b> .....	180
Trace window .....	180
Function Trace window .....	184
Trace Start breakpoints dialog box .....	185
Trace Stop breakpoints dialog box .....	186
Trace Expressions window .....	187
Find in Trace dialog box .....	189
Find in Trace window .....	190
<b>The application timeline</b> .....	191
<b>Introduction to analyzing your application's timeline</b> .....	191
Briefly about analyzing the timeline .....	191
Requirements for timeline support .....	193
<b>Analyzing your application's timeline</b> .....	193
Displaying a graph in the Timeline window .....	194
Navigating in the graphs .....	194
Analyzing performance using the graph data .....	195
Getting started using data logging .....	196
Getting started using data sampling .....	197
<b>Reference information on application timeline</b> .....	197
Timeline window—Call Stack graph .....	198
Timeline window—Data Log graph .....	201
Data Log window .....	205
Data Log Summary window .....	208
Sampled Graphs window .....	211
Data Sample Setup window .....	215
Data Sample window .....	216
Viewing Range dialog box .....	218

Profiling .....	221
<b>Introduction to the profiler</b> .....	221
Reasons for using the profiler .....	221
Briefly about the profiler .....	221
Requirements for using the profiler .....	222
<b>Using the profiler</b> .....	223
Getting started using the profiler on function level .....	223
Analyzing the profiling data .....	224
Getting started using the profiler on instruction level .....	225
<b>Reference information on the profiler</b> .....	226
Function Profiler window .....	226
Code coverage .....	231
<b>Introduction to code coverage</b> .....	231
Reasons for using code coverage .....	231
Briefly about code coverage .....	231
Requirements and restrictions for using code coverage .....	231
<b>Reference information on code coverage</b> .....	231
Code Coverage window .....	232
Power debugging .....	235
<b>Introduction to power debugging</b> .....	235
Reasons for using power debugging .....	235
Briefly about power debugging .....	235
Requirements and restrictions for power debugging .....	237
<b>Optimizing your source code for power consumption</b> .....	237
Waiting for device status .....	238
Software delays .....	238
DMA versus polled I/O .....	238
Low-power mode diagnostics .....	238
CPU frequency .....	239
Detecting mistakenly unattended peripherals .....	239
Peripheral units in an event-driven system .....	240
Finding conflicting hardware setups .....	241

Analog interference .....	241
<b>Debugging in the power domain .....</b>	<b>242</b>
Displaying a power profile and analyzing the result .....	242
Displaying the power profile on a device without EnergyTrace++ ..	243
Detecting unexpected power usage during application execution ...	244
Measuring low power currents .....	244
Changing the graph resolution .....	245
<b>Reference information on power debugging .....</b>	<b>245</b>
Power Log Setup window .....	246
Power Log window .....	248
Power graph in the Timeline window .....	251
State Log window .....	252
State Log Summary window .....	254
Timeline window—State Log graph .....	257

## **Part 3. Advanced debugging .....**

Interrupts .....	261
<b>Introduction to interrupts .....</b>	<b>261</b>
Briefly about the interrupt simulation system .....	261
Interrupt characteristics .....	262
Interrupt simulation states .....	263
C-SPY system macros for interrupt simulation .....	264
Target-adapting the interrupt simulation system .....	265
Briefly about interrupt logging .....	265
<b>Using the interrupt system .....</b>	<b>265</b>
Simulating a simple interrupt .....	266
Simulating an interrupt in a multi-task system .....	267
Getting started using interrupt logging .....	268
<b>Reference information on interrupts .....</b>	<b>268</b>
Interrupt Setup dialog box .....	269
Edit Interrupt dialog box .....	271
Forced Interrupt window .....	272
Interrupt Status window .....	273

Interrupt Log window .....	275
Interrupt Log Summary window .....	277
Timeline window—Interrupt Log graph .....	280
<b>The advanced cycle counter .....</b>	<b>283</b>
<b>Introduction to the advanced cycle counter .....</b>	<b>283</b>
Reasons for using the advanced cycle counter .....	283
Briefly about the advanced cycle counter .....	283
Requirements for using the advanced cycle counter .....	283
<b>Using the cycle counter applications .....</b>	<b>284</b>
Counting all CPU cycles .....	284
Measuring the DMA load versus the CPU load .....	284
Profiling a specific part of your application .....	285
Measuring the Trigger hits .....	286
Measuring the number of CPU cycles for a task .....	286
<b>Reference information on the advanced cycle counter .....</b>	<b>287</b>
Advanced Cycle Counter Control window .....	287
<b>State storage .....</b>	<b>291</b>
<b>Introduction to state storage .....</b>	<b>291</b>
Reasons for using state storage .....	291
Briefly about state storage .....	291
Requirements .....	291
<b>Using state storage .....</b>	<b>292</b>
Setting up state storage .....	292
<b>Reference information on state storage .....</b>	<b>293</b>
State Storage Control window .....	294
State Storage window .....	296
<b>The sequencer .....</b>	<b>299</b>
<b>Introduction to the sequencer .....</b>	<b>299</b>
Reasons for using the sequencer .....	299
Briefly about the sequencer .....	299
Requirements for using the sequencer .....	300

<b>Using the sequencer</b> .....	300
Setting up the sequencer (simple setup) .....	300
Setting up the sequencer (advanced setup) .....	300
Using the sequencer to locate a problem .....	301
<b>Reference information on the sequencer</b> .....	303
Sequencer Control window .....	303
<b>C-SPY macros</b> .....	305
<b>Introduction to C-SPY macros</b> .....	305
Reasons for using C-SPY macros .....	305
Briefly about using C-SPY macros .....	306
Briefly about setup macro functions and files .....	306
Briefly about the macro language .....	306
<b>Using C-SPY macros</b> .....	307
Registering C-SPY macros—an overview .....	308
Executing C-SPY macros—an overview .....	308
Registering and executing using setup macros and setup files .....	309
Executing macros using Quick Watch .....	309
Executing a macro by connecting it to a breakpoint .....	310
Aborting a C-SPY macro .....	311
<b>Reference information on the macro language</b> .....	312
Macro functions .....	312
Macro variables .....	312
Macro parameters .....	313
Macro strings .....	313
Macro statements .....	314
Formatted output .....	315
<b>Reference information on reserved setup macro function names</b> .....	317
execUserPreload .....	317
execUserExecutionStarted .....	318
execUserExecutionStopped .....	318
execUserSetup .....	318
execUserPreReset .....	319

execUserReset .....	319
execUserExit .....	319
<b>Reference information on C-SPY system macros .....</b>	<b>319</b>
__abortLaunch .....	321
__cancelAllInterrupts .....	322
__cancelInterrupt .....	322
__clearBreak .....	323
__closeFile .....	323
__delay .....	323
__disableInterrupts .....	324
__driverType .....	324
__enableInterrupts .....	325
__evaluate .....	325
__fillMemory8 .....	326
__fillMemory16 .....	326
__fillMemory32 .....	327
__isBatchMode .....	328
__loadImage .....	329
__memoryRestore .....	330
__memorySave .....	330
__messageBoxYesCancel .....	331
__messageBoxYesNo .....	332
__openFile .....	332
__orderInterrupt .....	334
__popSimulatorInterruptExecutingStack .....	335
__readFile .....	335
__readFileByte .....	336
__readMemory8, __readMemoryByte .....	336
__readMemory16 .....	337
__readMemory32 .....	337
__registerMacroFile .....	338
__resetFile .....	338
__setAdvancedTriggerBreak .....	339
__setCodeBreak .....	340

__setConditionalBreak .....	341
__setDataBreak .....	343
__setDataLogBreak .....	344
__setLogBreak .....	345
__setRangeBreak .....	346
__setSimBreak .....	347
__setTraceStartBreak .....	348
__setTraceStopBreak .....	349
__sourcePosition .....	350
__strFind .....	350
__subString .....	351
__targetDebuggerVersion .....	351
__toLower .....	352
__toString .....	352
__toUpper .....	353
__unloadImage .....	353
__writeFile .....	354
__writeFileByte .....	354
__writeMemory8, __writeMemoryByte .....	355
__writeMemory16 .....	355
__writeMemory32 .....	356
<b>Graphical environment for macros</b> .....	356
Macro Registration window .....	357
Debugger Macros window .....	359
Macro Quicklaunch window .....	361
<b>The C-SPY command line utility—cspybat</b> .....	363
<b>Using C-SPY in batch mode</b> .....	363
Starting cspybat .....	363
Output .....	364
Invocation syntax .....	364
<b>Summary of C-SPY command line options</b> .....	365
General cspybat options .....	365
Options available for all C-SPY drivers .....	366



Options available for the simulator driver .....	366
Options available for the C-SPY FET Debugger driver .....	366
<b>Reference information on C-SPY command line options ...</b>	<b>367</b>
--allow_access_to_BSL .....	368
--allow_locked_flash_access .....	368
--attach_to_running_target .....	368
--backend .....	369
--connection .....	369
--core .....	369
--code_coverage_file .....	370
--cycles .....	370
-d .....	371
--debugfile .....	371
--derivative .....	372
--disable_interrupts .....	372
--disable_memory_cache .....	372
--downloadonly .....	372
--eem .....	373
--erase_exclude .....	374
--erase_ip_protected .....	374
--erase_main .....	374
--erase_main_and_info .....	375
--erase_retain_file .....	375
--erase_retain_target .....	375
-f .....	376
--function_profiling .....	376
--hardware_multiplier .....	377
--hwmult_type .....	377
--jtag_speed .....	378
--leave_target_running .....	378
--lptx .....	379
--macro .....	379
--macro_param .....	380
--mapu .....	380

--odd_word_check .....	380
-p .....	381
--plugin .....	381
--port .....	382
--protocol .....	382
--set_exit_breakpoint .....	383
--set_getchar_breakpoint .....	383
--set_putchar_breakpoint .....	383
--settlingtime .....	383
--silent .....	384
--timeout .....	384
--use_emulated_breakpoints .....	384
--use_virtual_breakpoints .....	385
--vccvoltage .....	385
--verify_all .....	385

## **Part 4. Additional reference information** ..... 387

Debugger options .....	389
<b>Setting debugger options</b> .....	389
<b>Reference information on general debugger options</b> .....	390
Setup .....	390
Images .....	391
Plugins .....	392
Extra Options .....	393
<b>Reference information on the C-SPY simulator</b> .....	394
Setup options for the simulator .....	394
<b>Reference information on C-SPY hardware debugger driver options</b> .....	395
Setup for FET Debugger .....	395
Download .....	397
Breakpoints .....	398

Additional information on C-SPY drivers .....	401
<b>Reference information on C-SPY driver menus</b> .....	401
<i>C-SPY driver</i> .....	401
Simulator menu .....	402
Emulator menu .....	404
<b>Reference information on the C-SPY simulator</b> .....	407
Simulated Frequency dialog box .....	408
<b>Reference information on the C-SPY FET Debugger</b>	
<b>driver</b> .....	408
General Clock Control dialog box .....	408
Extended Clock Control dialog box .....	409
<b>Resolving problems</b> .....	409
The device port pins do not work .....	410
Write failure during load .....	410
No contact with the target hardware .....	411
Index .....	413



# Tables

1: Typographic conventions used in this guide .....	27
2: Naming conventions used in this guide .....	28
3: Driver differences .....	39
4: C-SPY assembler symbols expressions .....	81
5: Handling name conflicts between hardware registers and assembler labels .....	81
6: C-SPY macros for breakpoints .....	112
7: Support for timeline information .....	193
8: Supported graphs in the Timeline window .....	193
9: C-SPY driver profiling support .....	223
10: Project options for enabling the profiler .....	223
11: Project options for enabling code coverage .....	232
12: Timer interrupt settings .....	267
13: Cycle Counter 1, combinations of start, stop, and clear reactions .....	289
14: Sequencer settings - example .....	302
15: State Storage Control settings—example .....	302
16: Examples of C-SPY macro variables .....	313
17: Summary of system macros .....	319
18: __cancelInterrupt return values .....	322
19: __disableInterrupts return values .....	324
20: __driverType return values .....	324
21: __enableInterrupts return values .....	325
22: __evaluate return values .....	325
23: __isBatchMode return values .....	328
24: __loadImage return values .....	329
25: __messageBoxYesCancel return values .....	332
26: __messageBoxYesNo return values .....	332
27: __openFile return values .....	333
28: __readFile return values .....	335
29: __setAdvancedTriggerBreak return values .....	340
30: __setCodeBreak return values .....	341
31: __setConditionalBreak return values .....	342

32: __setDataBreak return values .....	343
33: __setDataLogBreak return values .....	344
34: __setLogBreak return values .....	345
35: __setRangeBreak return values .....	347
36: __setSimBreak return values .....	348
37: __setTraceStartBreak return values .....	348
38: __setTraceStopBreak return values .....	349
39: __sourcePosition return values .....	350
40: __unloadImage return values .....	354
41: cspybat parameters .....	364
42: Options specific to the C-SPY drivers you are using .....	389

# Preface

Welcome to the *C-SPY® Debugging Guide*. The purpose of this guide is to help you fully use the features in the IAR C-SPY® Debugger for debugging your application based on the MSP430 microcontroller.

---

## Who should read this guide

Read this guide if you plan to develop an application using IAR Embedded Workbench and want to get the most out of the features available in C-SPY.

### REQUIRED KNOWLEDGE

To use the tools in IAR Embedded Workbench, you should have working knowledge of:

- The architecture and instruction set of the MSP430 microcontroller (refer to the chip manufacturer's documentation)
- The C or C++ programming language
- Application development for embedded systems
- The operating system of your host computer.

For more information about the other development tools incorporated in the IDE, refer to their respective documentation, see *Other documentation*, page 25.

---

## How to use this guide

Each chapter in this guide covers a specific *topic area*. In many chapters, information is typically divided in different sections based on *information types*:

- *Concepts*, which describes the topic and gives overviews of features related to the topic area. Any requirements or restrictions are also listed. Read this section to learn about the topic area.
- *Tasks*, which lists useful tasks related to the topic area. For many of the tasks, you can also find step-by-step descriptions. Read this section for information about required tasks as well as for information about how to perform certain tasks.
- *Reference information*, which gives reference information related to the topic area. Read this section for information about certain GUI components. You can easily access this type of information for a certain component in the IDE by pressing F1.

If you are new to using IAR Embedded Workbench, we suggest that you first read the guide *Getting Started with IAR Embedded Workbench®* for an overview of the tools and the features that the IDE offers. The tutorials, which you can find in the IAR Information Center, will help you get started using IAR Embedded Workbench.

Finally, we recommend the *Glossary* if you should encounter any unfamiliar terms in the IAR Systems user documentation.

---

## What this guide contains

Below is a brief outline and summary of the chapters in this guide.

**Note:** Some of the screenshots in this guide are taken from a similar product and not from IAR Embedded Workbench for MSP430.

### PART I. BASIC DEBUGGING

- *The IAR C-SPY Debugger* introduces you to the C-SPY debugger and to the concepts that are related to debugging in general and to C-SPY in particular. The chapter also introduces the various C-SPY drivers. The chapter briefly shows the difference in functionality that the various C-SPY drivers provide.
- *Getting started using C-SPY* helps you get started using C-SPY, which includes setting up, starting, and adapting C-SPY for target hardware.
- *Executing your application* describes the conceptual differences between source and disassembly mode debugging, the facilities for executing your application, and finally, how you can handle terminal input and output.
- *Variables and expressions* describes the syntax of the expressions and variables used in C-SPY, as well as the limitations on variable information. The chapter also demonstrates the various methods for monitoring variables and expressions.
- *Breakpoints* describes the breakpoint system and the various ways to set breakpoints.
- *Memory and registers* shows how you can examine memory and registers.

### PART 2. ANALYZING YOUR APPLICATION

- *Trace* describes how you can inspect the program flow up to a specific state using trace data.
- *The application timeline* describes the **Timeline** window, and how to use the information in it to analyze your application's behavior.
- *Profiling* describes how the profiler can help you find the functions in your application source code where the most time is spent during execution.



- *Code coverage* describes how the code coverage functionality can help you verify whether all parts of your code have been executed, thus identifying parts which have not been executed.
- *Power debugging* describes techniques for power debugging and how you can use C-SPY to find source code constructions that result in unexpected power consumption.

### PART 3. ADVANCED DEBUGGING

- *Interrupts* contains detailed information about the C-SPY interrupt simulation system and how to configure the simulated interrupts to make them reflect the interrupts of your target hardware.
- *The advanced cycle counter* describes the advanced cycle counter for MSP430 devices, and how it can help you to profile your application or to measure how long some tasks take.
- *State storage* describes how the state storage module can help you to examine how your code is executed, and find problems in a specific stage of the execution.
- *The sequencer* describes the sequencer module, a simple state machine that lets you break the execution or trigger the state storage module using a more complex method than a standard breakpoint.
- *C-SPY macros* describes the C-SPY macro system, its features, the purposes of these features, and how to use them.
- *The C-SPY command line utility—cspybat* describes how to use C-SPY in batch mode.

### PART 4. ADDITIONAL REFERENCE INFORMATION

- *Debugger options* describes the options you must set before you start the C-SPY debugger.
- *Additional information on C-SPY drivers* describes menus and features provided by the C-SPY drivers not described in any dedicated topics.

---

## Other documentation

User documentation is available as hypertext PDFs and as a context-sensitive online help system in HTML format. You can access the documentation from the Information Center or from the **Help** menu in the IAR Embedded Workbench IDE. The online help system is also available via the F1 key.

## USER AND REFERENCE GUIDES

The complete set of IAR Systems development tools is described in a series of guides. Information about:

- System requirements and information about how to install and register the IAR Systems products, is available in the booklet Quick Reference (available in the product box) and the *Installation and Licensing Guide*.
- Getting started using IAR Embedded Workbench and the tools it provides, is available in the guide *Getting Started with IAR Embedded Workbench®*.
- Using the IDE for project management and building, is available in the *IDE Project Management and Building Guide*.
- Using the IAR C-SPY® Debugger, is available in the *C-SPY® Debugging Guide for MSP430*.
- Programming for the IAR C/C++ Compiler for MSP430, is available in the *IAR C/C++ Compiler User Guide for MSP430*.
- Using the IAR XLINK Linker, the IAR XAR Library Builder, and the IAR XLIB Librarian, is available in the *IAR Linker and Library Tools Reference Guide*.
- Programming for the IAR Assembler for MSP430, is available in the *IAR Assembler Reference Guide for MSP430*.
- Performing a static analysis using C-STAT and the required checks, is available in the *C-STAT® Static Analysis Guide*.
- Developing safety-critical applications using the MISRA C guidelines, is available in the *IAR Embedded Workbench® MISRA C:2004 Reference Guide* or the *IAR Embedded Workbench® MISRA C:1998 Reference Guide*.
- Porting application code and projects created with a previous version of the IAR Embedded Workbench for MSP430, is available in the *IAR Embedded Workbench® Migration Guide*.

**Note:** Additional documentation might be available depending on your product installation.

## THE ONLINE HELP SYSTEM

The context-sensitive online help contains:

- Information about project management, editing, and building in the IDE
- Information about debugging using the IAR C-SPY® Debugger
- Reference information about the menus, windows, and dialog boxes in the IDE
- Compiler reference information
- Keyword reference information for the DLIB library functions. To obtain reference information for a function, select the function name in the editor window and press

F1. Note that if you select a function name in the editor window and press F1 while using the CLIB C standard library, you will get reference information for the DLIB C/EC++ standard library.

## WEB SITES

Recommended web sites:

- The Texas Instruments web site, **www.ti.com**, that contains information and news about the MSP430 microcontrollers.
- The IAR Systems web site, **www.iar.com**, that holds application notes and other product information.
- The web site of the C standardization working group, **www.open-std.org/jtc1/sc22/wg14**.
- The web site of the C++ Standards Committee, **www.open-std.org/jtc1/sc22/wg21**.
- The C++ programming language web site, **isocpp.org**.  
This web site also has a list of recommended books about C++ programming.
- The C and C++ reference web site, **en.cppreference.com**.

---

## Document conventions

When, in the IAR Systems documentation, we refer to the programming language C, the text also applies to C++, unless otherwise stated.

When referring to a directory in your product installation, for example `430\doc`, the full path to the location is assumed, for example `c:\Program Files\IAR Systems\Embedded Workbench N.n\430\doc`, where the initial digit of the version number reflects the initial digit of the version number of the IAR Embedded Workbench shared components.

## TYPOGRAPHIC CONVENTIONS

The IAR Systems documentation set uses the following typographic conventions:

Style	Used for
<i>computer</i>	<ul style="list-style-type: none"> <li>• Source code examples and file paths.</li> <li>• Text on the command line.</li> <li>• Binary, hexadecimal, and octal numbers.</li> </ul>
<i>parameter</i>	A placeholder for an actual value used as a parameter, for example <i>filename.h</i> where <i>filename</i> represents the name of the file.

*Table 1: Typographic conventions used in this guide*





Style	Used for
[option]	An optional part of a directive, where [ and ] are not part of the actual directive, but any [, ], {, or } are part of the directive syntax.
{option}	A mandatory part of a directive, where { and } are not part of the actual directive, but any [, ], {, or } are part of the directive syntax.
[option]	An optional part of a command.
[a b c]	An optional part of a command with alternatives.
{a b c}	A mandatory part of a command with alternatives.
<b>bold</b>	Names of menus, menu commands, buttons, and dialog boxes that appear on the screen.
<i>italic</i>	<ul style="list-style-type: none"> <li>• A cross-reference within this guide or to another guide.</li> <li>• Emphasis.</li> </ul>
...	An ellipsis indicates that the previous item can be repeated an arbitrary number of times.
	Identifies instructions specific to the IAR Embedded Workbench® IDE interface.
	Identifies instructions specific to the command line interface.
	Identifies helpful tips and programming hints.
	Identifies warnings.

Table 1: Typographic conventions used in this guide (Continued)

## NAMING CONVENTIONS

The following naming conventions are used for the products and tools from IAR Systems®, when referred to in the documentation:

Brand name	Generic term
IAR Embedded Workbench® for MSP430	IAR Embedded Workbench®
IAR Embedded Workbench® IDE for MSP430	the IDE
IAR C-SPY® Debugger for MSP430	C-SPY, the debugger
IAR C-SPY® Simulator	the simulator
IAR C/C++ Compiler™ for MSP430	the compiler
IAR Assembler™ for MSP430	the assembler
IAR XLINK Linker™	XLINK, the linker
IAR XAR Library Builder™	the library builder

Table 2: Naming conventions used in this guide

<b>Brand name</b>	<b>Generic term</b>
IAR XLIB Librarian™	the librarian
IAR DLIB Runtime Environment™	the DLIB runtime environment
IAR CLIB Runtime Environment™	the CLIB runtime environment

*Table 2: Naming conventions used in this guide (Continued)*



# Part I. Basic debugging

This part of the *C-SPY® Debugging Guide for MSP430* includes these chapters:

- The IAR C-SPY Debugger
- Getting started using C-SPY
- Executing your application
- Variables and expressions
- Breakpoints
- Memory and registers

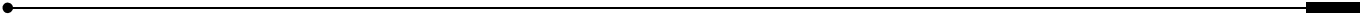
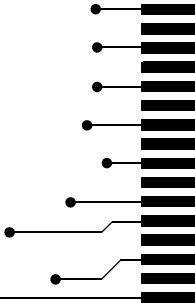





# The IAR C-SPY Debugger

- Introduction to C-SPY
- Debugger concepts
- C-SPY drivers overview
- The IAR C-SPY Simulator
- The C-SPY hardware debugger drivers

---

## Introduction to C-SPY

These topics are covered:

- An integrated environment
- General C-SPY debugger features
- RTOS awareness

### AN INTEGRATED ENVIRONMENT

C-SPY is a high-level-language debugger for embedded applications. It is designed for use with the IAR Systems compilers and assemblers, and is completely integrated in the IDE, providing development and debugging within the same application. This will give you possibilities such as:

- Editing while debugging. During a debug session, you can make corrections directly in the same source code window that is used for controlling the debugging. Changes will be included in the next project rebuild.
- Setting breakpoints at any point during the development cycle. You can inspect and modify breakpoint definitions also when the debugger is not running, and breakpoint definitions flow with the text as you edit. Your debug settings, such as watch properties, window layouts, and register groups will be preserved between your debug sessions.

All windows that are open in the Embedded Workbench workspace will stay open when you start the C-SPY Debugger. In addition, a set of C-SPY-specific windows are opened.

## GENERAL C-SPY DEBUGGER FEATURES

Because IAR Systems provides an entire toolchain, the output from the compiler and linker can include extensive debug information for the debugger, resulting in good debugging possibilities for you.

C-SPY offers these general features:

- Source and disassembly level debugging
 

C-SPY allows you to switch between source and disassembly debugging as required, for both C or C++ and assembler source code.
- Single-stepping on a function call level
 

Compared to traditional debuggers, where the finest granularity for source level stepping is line by line, C-SPY provides a finer level of control by identifying every statement and function call as a step point. This means that each function call—inside expressions, and function calls that are part of parameter lists to other functions—can be single-stepped. The latter is especially useful when debugging C++ code, where numerous extra function calls are made, for example to object constructors.
- Code and data breakpoints
 

The C-SPY breakpoint system lets you set breakpoints of various kinds in the application being debugged, allowing you to stop at locations of particular interest. For example, you set breakpoints to investigate whether your program logic is correct or to investigate how and when the data changes.
- Monitoring variables and expressions
 

For variables and expressions there is a wide choice of facilities. You can easily monitor values of a specified set of variables and expressions, continuously or on demand. You can also choose to monitor only local variables, static variables, etc.
- Container awareness
 

When you run your application in C-SPY, you can view the elements of library data types such as STL lists and vectors. This gives you a very good overview and debugging opportunities when you work with C++ STL containers.
- Call stack information
 

The compiler generates extensive call stack information. This allows the debugger to show, without any runtime penalty, the complete stack of function calls wherever the program counter is. You can select any function in the call stack, and for each function you get valid information for local variables and available registers.
- Powerful macro system
 

C-SPY includes a powerful internal macro system, to allow you to define complex sets of actions to be performed. C-SPY macros can be used on their own or in

conjunction with complex breakpoints and—if you are using the simulator—the interrupt simulation system to perform a wide variety of tasks.

### **Additional general C-SPY debugger features**

This list shows some additional features:

- Threaded execution keeps the IDE responsive while running the target application
- Automatic stepping
- The source browser provides easy navigation to functions, types, and variables
- Extensive type recognition of variables
- Configurable registers (CPU and peripherals) and memory windows
- Graphical stack view with overflow detection
- Support for code coverage and function level profiling
- The target application can access files on the host PC using file I/O (requires the DLIB library)
- UBROF, Intel-Standard, Intel-extended, Motorola, and TI msp430-txt input formats supported
- Optional terminal I/O emulation.

### **RTOS AWARENESS**

C-SPY supports RTOS-aware debugging.

These operating systems are currently supported:

- CMX
- FreeRTOS, OpenRTOS, and SafeRTOS
- Micrium uC/OS-II
- Micrium uC/OS-III
- OSEK
- Segger embOS
- TI-RTOS

RTOS plugin modules can be provided by IAR Systems, and by third-party suppliers. Contact your software distributor or IAR Systems representative, alternatively visit the IAR Systems web site, for information about supported RTOS modules.

A C-SPY RTOS awareness plugin module gives you a high level of control and visibility over an application built on top of an RTOS. It displays RTOS-specific items like task lists, queues, semaphores, mailboxes, and various RTOS system variables. Task-specific breakpoints and task-specific stepping make it easier to debug tasks.

A loaded plugin will add its own menu, set of windows, and buttons when a debug session is started (provided that the RTOS is linked with the application). For information about other RTOS awareness plugin modules, refer to the manufacturer of the plugin module.

---

## Debugger concepts

This section introduces some of the concepts and terms that are related to debugging in general and to C-SPY in particular. This section does not contain specific information related to C-SPY features. Instead, you will find such information in the other chapters of this documentation. The IAR Systems user documentation uses the terms described in this section when referring to these concepts.

These topics are covered:

- C-SPY and target systems
- The debugger
- The target system
- The application
- C-SPY debugger systems
- The ROM-monitor program
- Third-party debuggers
- C-SPY plugin modules

### **C-SPY AND TARGET SYSTEMS**

You can use C-SPY to debug either a software target system or a hardware target system.

This figure gives an overview of C-SPY and possible target systems:

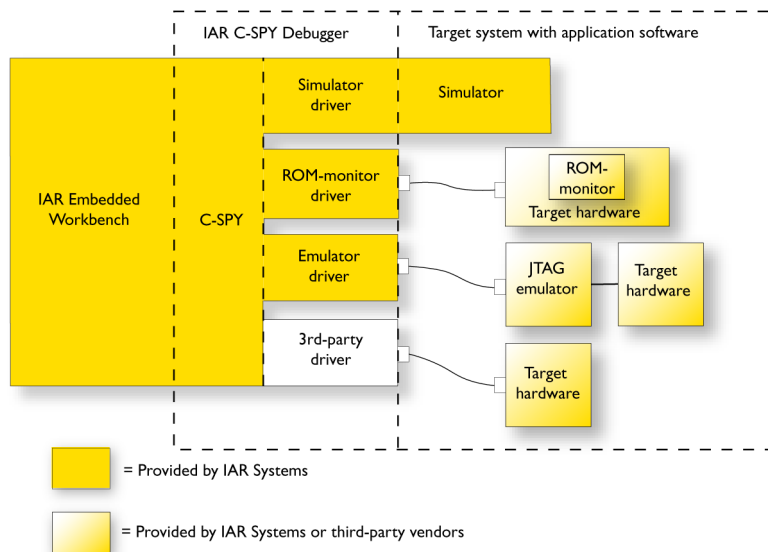

**Note:** In IAR Embedded Workbench for MSP430, there are no ROM-monitor drivers.

## THE DEBUGGER

The debugger, for instance C-SPY, is the program that you use for debugging your applications on a target system.

## THE TARGET SYSTEM

The target system is the system on which you execute your application when you are debugging it. The target system can consist of hardware, either an evaluation board or your own hardware design. It can also be completely or partially simulated by software. Each type of target system needs a dedicated C-SPY driver.

## THE APPLICATION

A user application is the software you have developed and which you want to debug using C-SPY.

## C-SPY DEBUGGER SYSTEMS

C-SPY consists of both a general part which provides a basic set of debugger features, and a target-specific back end. The back end consists of two components: a processor module—one for every microcontroller, which defines the properties of the

microcontroller, and a *C-SPY driver*. The C-SPY driver is the part that provides communication with and control of the target system. The driver also provides the user interface—menus, windows, and dialog boxes—to the functions provided by the target system, for instance, special breakpoints. Typically, there are three main types of C-SPY drivers:

- Simulator driver
- ROM-monitor driver
- Emulator driver.

C-SPY is available with a simulator driver, and depending on your product package, optional drivers for hardware debugger systems. For an overview of the available C-SPY drivers and the functionality provided by each driver, see *C-SPY drivers overview*, page 39.

## THE ROM-MONITOR PROGRAM

The ROM-monitor program is a piece of firmware that is loaded to non-volatile memory on your target hardware; it runs in parallel with your application. The ROM-monitor communicates with the debugger and provides services needed for debugging the application, for instance stepping and breakpoints.

## THIRD-PARTY DEBUGGERS

You can use a third-party debugger together with the IAR Systems toolchain as long as the third-party debugger can read any of the output formats provided by XLINK, such as UBROF, ELF/DWARF, COFF, Intel-extended, Motorola, TI msp430-txt, or any other available format. For information about which format to use with a third-party debugger, see the user documentation supplied with that tool.

## C-SPY PLUGIN MODULES

C-SPY is designed as a modular architecture with an open SDK that can be used for implementing additional functionality to the debugger in the form of plugin modules. These modules can be seamlessly integrated in the IDE.

Plugin modules are provided by IAR Systems, or can be supplied by third-party vendors. Examples of such modules are:

- Code Coverage, which is integrated in the IDE.
- The various C-SPY drivers for debugging using certain debug systems.
- RTOS plugin modules for support for real-time OS aware debugging.
- C-SPYLink that bridges IAR visualSTATE and IAR Embedded Workbench to make true high-level state machine debugging possible directly in C-SPY, in addition to

the normal C level symbolic debugging. For more information, see the documentation provided with IAR visualSTATE.

For more information about the C-SPY SDK, contact IAR Systems.

---

## C-SPY drivers overview

At the time of writing this guide, the IAR C-SPY Debugger for the MSP430 microcontrollers is available with drivers for these target systems and evaluation boards:

- Simulator
- FET Debugger.

### DIFFERENCES BETWEEN THE C-SPY DRIVERS

This table summarizes the key differences between the C-SPY drivers:

Feature	Simulator	FET Debugger
Code breakpoints	Unlimited	Yes <sup>1</sup>
Data breakpoints	Yes	—
Execution in real time	—	Yes
Zero memory footprint	Yes	Yes
Simulated interrupts	Yes	—
Real interrupts	—	Yes
Interrupt logging	Yes	—
Data logging	Yes	—
Live watch	Yes	—
Cycle counter	Yes	Yes <sup>1</sup>
Code coverage	Yes	—
Data coverage	Yes	—
Function/instruction profiling	Yes	— <sup>1</sup>
Trace	Yes	—
Power debugging <sup>1</sup>	—	Yes

*Table 3: Driver differences*

<sup>1</sup> With specific requirements or restrictions, see the respective chapter in this guide.

---

## The IAR C-SPY Simulator

The C-SPY Simulator simulates the functions of the target processor entirely in software, which means that you can debug the program logic long before any hardware is available. Because no hardware is required, it is also the most cost-effective solution for many applications.

The C-SPY Simulator supports:

- Instruction-level simulation
- Memory configuration and validation
- Interrupt simulation
- Peripheral simulation (using the C-SPY macro system in conjunction with immediate breakpoints).

Simulating hardware instead of using a hardware debugging system means that some limitations do not apply, but that there are other limitations instead. For example:

- You can set an unlimited number of breakpoints in the simulator.
- When you stop executing your application, time actually stops in the simulator. When you stop application execution on a hardware debugging system, there might still be activities in the system. For example, peripheral units might still be active and reading from or writing to SFR ports.
- Application execution is significantly much slower in a simulator compared to when using a hardware debugging system. However, during a debug session, this might not necessarily be a problem.
- The simulator is not cycle accurate.
- Peripheral simulation is limited in the C-SPY Simulator and therefore the simulator is suitable mostly for debugging code that does not interact too much with peripheral units.

---

## The C-SPY hardware debugger drivers

The C-SPY Flash Emulator Tool Debugger is a JTAG debugger that supports all Texas Instruments' debug probes and boards, and several third-party JTAG debug probes. It provides automatic flash downloading and takes advantage of on-chip debug facilities.

To make the C-SPY FET Debugger work, a communication driver must be installed on the host PC. This driver is automatically installed during the installation of the IAR Embedded Workbench IDE. Because the hardware debugger kernel is built into the microcontroller, no ordinary ROM-monitor program or extra specific hardware is needed to make the debugging work. You can also use the debugger on your own hardware design.



At the time of writing this guide, the IAR C-SPY Debugger for the MSP430 microcontrollers is available with drivers for these JTAG debug probes supported by the FET debugger driver:

- MSP-FET430UIF
- MSP-FET
- eZFET
- eZ430
- Olimex JTAG interface
- Elprotronic JTAG interface.

## FEATURES

In addition to the general features of C-SPY, the FET Debugger driver also provides:

- Execution in real time with full access to the microcontroller
- High-speed communication through a JTAG interface
- Zero memory footprint on the target system
- Hardware code breakpoints
- Built-in flash loader.

Depending on the level of Enhanced Emulation Module (EEM) support, you might have access also to:

- State storage
- Sequencer
- Clock control.

## COMMUNICATION OVERVIEW

Most target systems have a debug probe or a debug adapter connected between the host computer and the evaluation board.

The C-SPY FET Debugger driver uses the USB or parallel port to communicate with the FET Interface module. The FET Interface module communicates with the JTAG interface on the hardware.

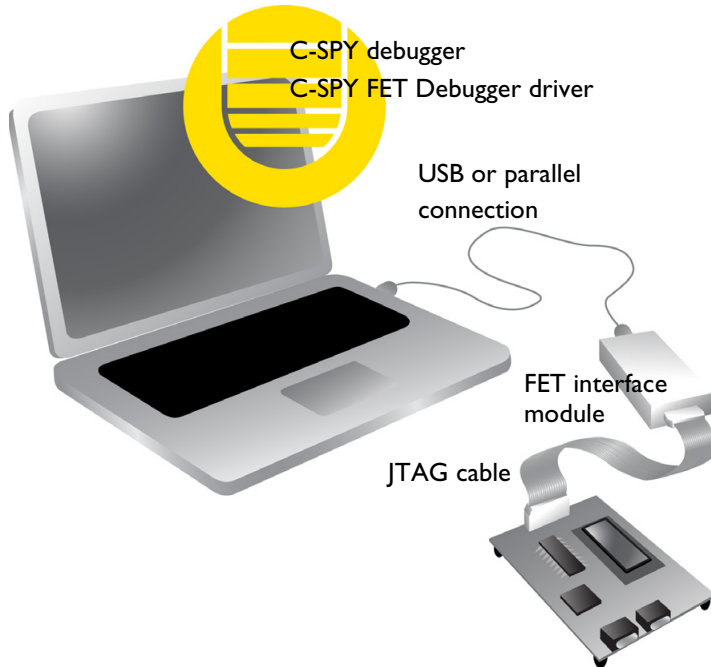

For further information, refer to the documentation supplied with the FET Debugger.

When a debug session is started, your application is automatically downloaded and programmed into flash memory. You can disable this feature, if necessary.

### Hardware installation

For information about the hardware installation, see the documentation supplied with the hardware debugger from Texas Instruments. The following power-up sequence is recommended to ensure proper communication between the target board, hardware debugger, and C-SPY:

- 1 Power up the target board.
- 2 Power up the hardware debugger.
- 3 Start the C-SPY debug session.

# Getting started using C-SPY

- Setting up C-SPY
- Starting C-SPY
- Adapting for target hardware
- Reference information on starting C-SPY

---

## Setting up C-SPY

These tasks are covered:

- Setting up for debugging
- Executing from reset
- Using a setup macro file
- Selecting a device description file
- Loading plugin modules

### SETTING UP FOR DEBUGGING

- 1** Before you start C-SPY, choose **Project>Options>Debugger>Setup** and select the C-SPY driver that matches your debugger system: simulator or a hardware debugger system.
- 2** In the **Category** list, select the appropriate C-SPY driver and make your settings.  
For information about these options, see *Debugger options*, page 389.
- 3** Click **OK**.
- 4** Choose **Tools>Options** to open the **IDE Options** dialog box:
  - Select **Debugger** to configure the debugger behavior
  - Select **Stack** to configure the debugger's tracking of stack usage.

For more information about these options, see the *IDE Project Management and Building Guide*.

See also *Adapting for target hardware*, page 48.

## EXECUTING FROM RESET

The **Run to** option—available on the **Debugger>Setup** page—specifies a location you want C-SPY to run to when you start a debug session as well as after each reset. C-SPY will place a temporary breakpoint at this location and all code up to this point is executed before stopping at the location. Note that this temporary breakpoint is removed when the debugger stops, regardless of how. If you stop the execution before the **Run to** location has been reached, the execution will not stop at that location when you start the execution again.

The default location to run to is the `main` function. Type the name of the location if you want C-SPY to run to a different location. You can specify assembler labels or whatever can be evaluated to such, for instance function names.

If you leave the check box empty,

## USING A SETUP MACRO FILE

A setup macro file is a macro file that you choose to load automatically when C-SPY starts. You can define the setup macro file to perform actions according to your needs, using setup macro functions and system macros. Thus, if you load a setup macro file you can initialize C-SPY to perform actions automatically.

For more information about setup macro files and functions, see *Introduction to C-SPY macros*, page 305. For an example of how to use a setup macro file, see *Initializing target hardware before C-SPY starts*, page 49.

### To register a setup macro file:

- 1 Before you start C-SPY, choose **Project>Options>Debugger>Setup**.
- 2 Select **Use macro file** and type the path and name of your setup macro file, for example `Setup.mac`. If you do not type a filename extension, the extension `mac` is assumed.

## SELECTING A DEVICE DESCRIPTION FILE

C-SPY uses device description files to handle device-specific information.

A default device description file is automatically used based on your project settings. If you want to override the default file, you must select your device description file. Device description files are provided in the `msp430\config` directory and they have the filename extension `ddf`.

For more information about device description files, see *Adapting for target hardware*, page 48.

**To override the default device description file:**

- 1 Before you start C-SPY, choose **Project>Options>Debugger>Setup**.
- 2 Enable the use of a device description file and select a file using the **Device description file** browse button.

**Note:** You can easily view your device description files that are used for your project. Choose **Project>Open Device Description File** and select the file you want to view.

**LOADING PLUGIN MODULES**

On the **Plugins** page you can specify C-SPY plugin modules to load and make available during debug sessions. Plugin modules can be provided by IAR Systems, and by third-party suppliers. Contact your software distributor or IAR Systems representative, or visit the IAR Systems web site, for information about available modules.

For more information, see *Plugins*, page 392.

---

## Starting C-SPY

When you have set up the debugger, you are ready to start a debug session.

These tasks are covered:

- Starting a debug session
- Loading executable files built outside of the IDE
- Starting a debug session with source files missing
- Loading multiple images
- Editing in C-SPY windows

**STARTING A DEBUG SESSION**

You can choose to start a debug session with or without loading the current executable file.



To start C-SPY and download the current executable file, click the **Download and Debug** button. Alternatively, choose **Project>Download and Debug**.



To start C-SPY without downloading the current executable file, click the **Debug without Downloading** button. Alternatively, choose **Project>Debug without Downloading**.

## LOADING EXECUTABLE FILES BUILT OUTSIDE OF THE IDE

You can also load C-SPY with an application that was built outside the IDE, for example applications built on the command line. To load an externally built executable file and to set build options you must first create a project for it in your workspace.

### To create a project for an externally built file:

- 1 Choose **Project>Create New Project**, and specify a project name.
- 2 To add the executable file to the project, choose **Project>Add Files** and make sure to choose **All Files** in the **Files of type** drop-down list. Locate the executable file.
- 3 To start the executable file, click the **Download and Debug** button. The project can be reused whenever you rebuild your executable file.

The only project options that are meaningful to set for this kind of project are options in the **General Options** and **Debugger** categories. Make sure to set up the general project options in the same way as when the executable file was built.

## STARTING A DEBUG SESSION WITH SOURCE FILES MISSING

Normally, when you use the IAR Embedded Workbench IDE to edit source files, build your project, and start the debug session, all required files are available and the process works as expected.

However, if C-SPY cannot automatically find the source files, for example if the application was built on another computer, the **Get Alternative File** dialog box is displayed:

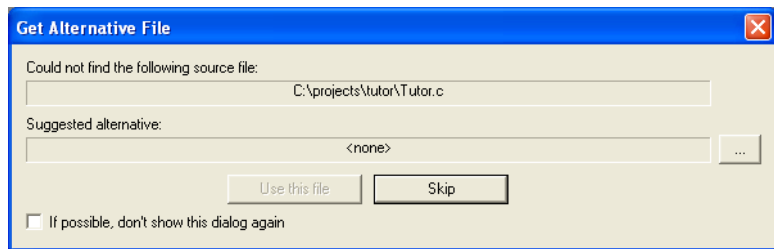

Typically, you can use the dialog box like this:

- The source files are not available: Click **If possible, don't show this dialog again** and then click **Skip**. C-SPY will assume that there simply is no source file available. The dialog box will not appear again, and the debug session will not try to display the source code.
- Alternative source files are available at another location: Specify an alternative source code file, click **If possible, don't show this dialog again**, and then click **Use**

**this file.** C-SPY will assume that the alternative file should be used. The dialog box will not appear again, unless a file is needed for which there is no alternative file specified and which cannot be located automatically.

If you restart the IAR Embedded Workbench IDE, the **Get Alternative File** dialog box will be displayed again once even if you have clicked **If possible, don't show this dialog again**. This gives you an opportunity to modify your previous settings.

For more information, see *Get Alternative File dialog box*, page 55.

## LOADING MULTIPLE IMAGES

Normally, a debuggable application consists of exactly one file that you debug. However, you can also load additional debug files (images). This means that the complete program consists of several images.

Typically, this is useful if you want to debug your application in combination with a prebuilt ROM image that contains an additional library for some platform-provided features. The ROM image and the application are built using separate projects in the IAR Embedded Workbench IDE and generate separate output files.

If more than one image has been loaded, you will have access to the combined debug information for all the loaded images. In the Images window you can choose whether you want to have access to debug information for one image or for all images.

### To load additional images at C-SPY startup:

- 1 Choose **Project>Options>Debugger>Images** and specify up to three additional images to be loaded. For more information, see *Images*, page 391.
- 2 Start the debug session.

To load additional images at a specific moment:

Use the `__loadImage` system macro and execute it using either one of the methods described in *Using C-SPY macros*, page 307.

To display a list of loaded images:

Choose **Images** from the **View** menu. The **Images** window is displayed, see *Images window*, page 54.

## EDITING IN C-SPY WINDOWS

You can edit the contents of the **Memory**, **Symbolic Memory**, **Registers**, **Register User Groups Setup**, **Auto**, **Watch**, **Locals**, **Statics**, **Live Watch**, and **Quick Watch** windows.

Use these keyboard keys to edit the contents of these windows:

<b>Enter</b>	Makes an item editable and saves the new value.
<b>Esc</b>	Cancels a new value.

In windows where you can edit the **Expression** field and in the **Quick Watch** window, you can specify the number of elements to be displayed in the field by adding a semicolon followed by an integer. For example, to display only the three first elements of an array named `myArray`, or three elements in sequence starting with the element pointed to by a pointer, write:

```
myArray;3
```

To display three elements pointed to by `myPtr`, `myPtr+1`, and `myPtr+2`, write:

```
myPtr;3
```

Optionally, add a comma and another integer that specifies which element to start with. For example, to display elements 10–14, write:

```
myArray;5,10
```

To display `myPtr+10`, `myPtr+11`, `myPtr+12`, `myPtr+13`, and `myPtr+14`, write:

```
myPtr;5,10
```

**Note:** For pointers, there are no built-in limits on displayed element count, and no validation of the pointer value.

---

## Adapting for target hardware

These tasks are covered:

- Modifying a device description file
- Initializing target hardware before C-SPY starts
- Using predefined C-SPY macros for device support

### MODIFYING A DEVICE DESCRIPTION FILE

C-SPY uses device description files provided with the product to handle several of the target-specific adaptations, see *Selecting a device description file*, page 44. They contain device-specific information such as:

- Memory information for device-specific memory zones, see *C-SPY memory zones*, page 138.
- Definitions of memory-mapped peripheral units, device-specific CPU registers, and groups of these.



- Definitions for device-specific interrupts, which makes it possible to simulate these interrupts in the C-SPY simulator; see *Interrupts*, page 261.

Normally, you do not need to modify the device description file. However, if the predefinitions are not sufficient for some reason, you can edit the file. Note, however, that the format of these descriptions might be updated in future upgrades of the product.

Make a copy of the device description file that best suits your needs, and modify it according to the description in the file. Reload the project to make the changes take effect.

For information about how to load a device description file, see *Selecting a device description file*, page 44.

## INITIALIZING TARGET HARDWARE BEFORE C-SPY STARTS

You can use C-SPY macros to initialize target hardware before C-SPY starts. For example, if your hardware uses external memory that must be enabled before code can be downloaded to it, C-SPY needs a macro to perform this action before your application can be downloaded.

- 1 Create a new text file and define your macro function.

By using the built-in `execUserPreload` setup macro function, your macro function will be executed directly after the communication with the target system is established but before C-SPY downloads your application.

For example, a macro that enables external SDRAM could look like this:

```
/* Your macro function. */
enableExternalSDRAM()
{
    __message "Enabling external SDRAM\n";
    __writeMemory32(...);
}

/* Setup macro determines time of execution. */
execUserPreload()
{
    enableExternalSDRAM();
}
```

- 2 Save the file with the filename extension `mac`.
- 3 Before you start C-SPY, choose **Project>Options>Debugger** and click the **Setup** tab.
- 4 Select the option **Use Setup file** and choose the macro file you just created.

Your setup macro will now be loaded during the C-SPY startup sequence.

## USING PREDEFINED C-SPY MACROS FOR DEVICE SUPPORT

For some MSP430 devices, there are predefined C-SPY macros available for specific device support, typically provided by the chip manufacturer. These macros are useful for performing certain device-specific tasks,

You can easily access and execute these macros using the **Macro Quicklaunch** window.

---

## Reference information on starting C-SPY

Reference information about:

- *C-SPY Debugger main window*, page 50
- *Images window*, page 54
- *Get Alternative File dialog box*, page 55
- *Device Information window*, page 56

See also:

- Tools options for the debugger in the *IDE Project Management and Building Guide*.

## C-SPY Debugger main window

When you start a debug session, these debugger-specific items appear in the main IAR Embedded Workbench IDE window:

- A dedicated **Debug** menu with commands for executing and debugging your application
- Depending on the C-SPY driver you are using, a driver-specific menu, often referred to as the *Driver menu* in this documentation. Typically, this menu contains menu commands for opening driver-specific windows and dialog boxes.
- A special debug toolbar
- Several windows and dialog boxes specific to C-SPY.

The C-SPY main window might look different depending on which components of the product installation you are using.

### Menu bar

These menus are available during a debug session:

#### Debug

Provides commands for executing and debugging the source application. Most of the commands are also available as icon buttons on the debug toolbar.

### C-SPY driver menu

Provides commands specific to a C-SPY driver. The driver-specific menu is only available when the driver is used. For information about the driver-specific menu commands, see *Reference information on C-SPY driver menus*, page 401.

## Debug menu

The **Debug** menu is available during a debug session. The **Debug** menu provides commands for executing and debugging the source application. Most of the commands are also available as icon buttons on the debug toolbar.

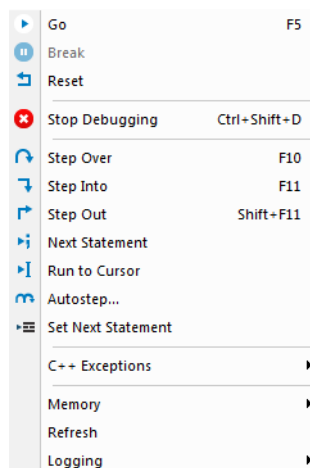

These commands are available:

#### **Go (F5)**

Executes from the current statement or instruction until a breakpoint or program exit is reached.

#### **Break**

Stops the application execution.



#### **Reset**

Resets the target processor. Click the drop-down button to access a menu with additional commands.

**Enable Run to 'label'**, where *label* typically is *main*. Enables and disables the project option **Run to** without exiting the debug session. This menu command is only available if you have selected **Run to** in the **Options** dialog box.

**Reset strategies**, which contains a list of reset strategies supported by the C-SPY driver you are using. This means that you can choose a different reset strategy than the one used initially without exiting the debug session. Reset strategies are only available if the C-SPY driver you are using supports alternate reset strategies.



### Stop Debugging (Ctrl+Shift+D)

Stops the debugging session and returns you to the project manager.



### Step Over (F10)

Executes the next statement, function call, or instruction, without entering C or C++ functions or assembler subroutines.



### Step Into (F11)

Executes the next statement or instruction, or function call, entering C or C++ functions or assembler subroutines.



### Step Out (Shift+F11)

Executes from the current statement up to the statement after the call to the current function.



### Next Statement

Executes directly to the next statement without stopping at individual function calls.



### Run to Cursor

Executes from the current statement or instruction up to a selected statement or instruction.



### Autostep

Displays a dialog box where you can customize and perform autostepping, see *Autostep settings dialog box*, page 78.



### Set Next Statement

Moves the program counter directly to where the cursor is, without executing any source code. Note, however, that this creates an anomaly in the program flow and might have unexpected effects.

### C++ Exceptions>

#### Break on Throw

This menu command is not supported by your product package.

### C++ Exceptions>

#### Break on Uncaught Exception

This menu command is not supported by your product package.

**Memory>Save**

Displays a dialog box where you can save the contents of a specified memory area to a file, see *Memory Save dialog box*, page 149.

**Memory>Restore**

Displays a dialog box where you can load the contents of a file in, for example Intel-extended, TI msp430-txt, or Motorola s-record format to a specified memory zone, see *Memory Restore dialog box*, page 150.

**Refresh**

Refreshes the contents of all debugger windows. Because window updates are automatic, this is needed only in unusual situations, such as when target memory is modified in ways C-SPY cannot detect. It is also useful if code that is displayed in the Disassembly window is changed.

**Logging>Set Log file**

Displays a dialog box where you can choose to log the contents of the **Debug Log** window to a file. You can select the type and the location of the log file. You can choose what you want to log: errors, warnings, system information, user messages, or all of these. See *Log File dialog box*, page 77.

**Logging>****Set Terminal I/O Log file**

Displays a dialog box where you can choose to log simulated target access communication to a file. You can select the destination of the log file. See *Terminal I/O Log File dialog box*, page 74

**C-SPY windows**

Depending on the C-SPY driver you are using, these windows specific to C-SPY are available during a debug session:

- C-SPY Debugger main window
- Disassembly window
- Memory window
- Symbolic Memory window
- Registers window
- Watch window
- Locals window
- Auto window
- Live Watch window
- Quick Watch window

- Statics window
- Call Stack window
- Trace window
- Function Trace window
- Timeline window, see *Reference information on application timeline*, page 197
- Terminal I/O window
- Code Coverage window
- Function Profiler window
- Images window
- Stack window
- Symbols window.

Additional windows are available depending on which C-SPY driver you are using.

## Images window

The **Images** window is available from the **View** menu.

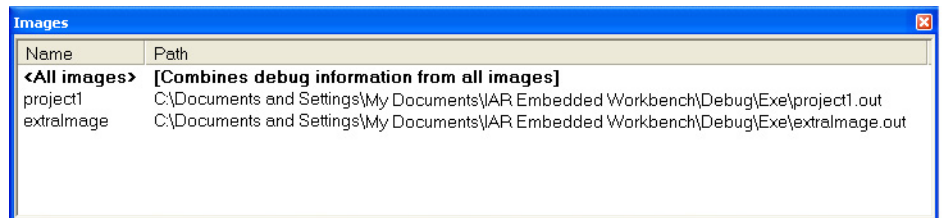

This window lists all currently loaded images (debug files).

Normally, a source application consists of exactly one image that you debug. However, you can also load additional images. This means that the complete debuggable unit consists of several images. See also *Loading multiple images*, page 47.

### Requirements

None; this window is always available.

### Display area

C-SPY can either use debug information from all of the loaded images simultaneously, or from one image at a time. Double-click on a row to show information only for that image. The current choice is highlighted.

This area lists the loaded images in these columns:

**Name**

The name of the loaded image.

**Path**

The path to the loaded image.

**Context menu**

This context menu is available:

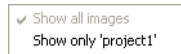

These commands are available:

**Show all images**

Shows debug information for all loaded debug images.

**Show only *image***

Shows debug information for the selected debug image.

**Related information**

For related information, see:

- *Loading multiple images*, page 47
- *Images*, page 391
- *\_\_loadImage*, page 329.

## Get Alternative File dialog box

The **Get Alternative File** dialog box is displayed if C-SPY cannot automatically find the source files to be loaded, for example if the application was built on another computer.

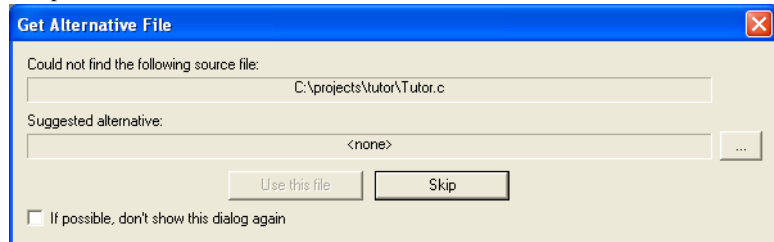

See also *Starting a debug session with source files missing*, page 46.

### Could not find the following source file

The missing source file.

### Suggested alternative

Specify an alternative file.

### Use this file

After you have specified an alternative file, **Use this file** establishes that file as the alias for the requested file. Note that after you have chosen this action, C-SPY will automatically locate other source files if these files reside in a directory structure similar to the first selected alternative file.

The next time you start a debug session, the selected alternative file will be preloaded automatically.

### Skip

C-SPY will assume that the source file is not available for this debug session.

### If possible, don't show this dialog again

Instead of displaying the dialog box again for a missing source file, C-SPY will use the previously supplied response.

### Related information

For related information, see *Starting a debug session with source files missing*, page 46.

## Device Information window

The **Device Information** window is available from the **Emulator** menu.

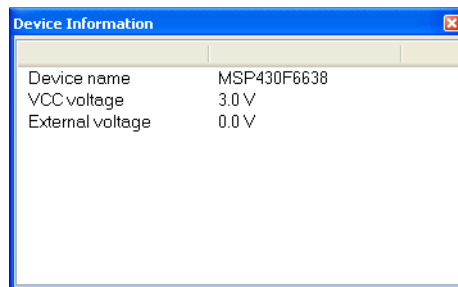

Displays information about the target hardware being used.



## Requirements

The C-SPY FET Debugger driver.



# Executing your application

- Introduction to application execution
- Reference information on application execution

---

## Introduction to application execution

These topics are covered:

- Briefly about application execution
- Source and disassembly mode debugging
- Single stepping
- Troubleshooting slow stepping speed
- Running the application
- Highlighting
- Viewing the call stack
- Terminal input and output
- Debug logging

### **BRIEFLY ABOUT APPLICATION EXECUTION**

C-SPY allows you to monitor and control the execution of your application. By single-stepping through it, and setting breakpoints, you can examine details about the application execution, for example the values of variables and registers. You can also use the call stack to step back and forth in the function call chain.

The terminal I/O and debug log features let you interact with your application.

You can find commands for execution on the **Debug** menu and on the toolbar.

### **SOURCE AND DISASSEMBLY MODE DEBUGGING**

C-SPY allows you to switch between source mode and disassembly mode debugging as needed.

Source debugging provides the fastest and easiest way of developing your application, without having to worry about how the compiler or assembler has implemented the code. In the editor windows you can execute the application one statement at a time while monitoring the values of variables and data structures.

Disassembly mode debugging lets you focus on the critical sections of your application, and provides you with precise control of the application code. You can open a disassembly window which displays a mnemonic assembler listing of your application based on actual memory contents rather than source code, and lets you execute the application exactly one machine instruction at a time.

Regardless of which mode you are debugging in, you can display registers and memory, and change their contents.

## SINGLE STEPPING

C-SPY allows more stepping precision than most other debuggers because it is not line-oriented but statement-oriented. The compiler generates detailed stepping information in the form of *step points* at each statement, and at each function call. That is, source code locations where you might consider whether to execute a step into or a step over command. Because the step points are located not only at each statement but also at each function call, the step functionality allows a finer granularity than just stepping on statements.

There are several factors that can slow down the stepping speed. If you find it too slow, see *Troubleshooting slow stepping speed*, page 63 for some tips.

### The step commands

There are four step commands:

- **Step Into**
- **Step Over**
- **Next Statement**
- **Step Out.**

Using the **Autostep settings** dialog box, you can automate the single stepping. For more information, see *Autostep settings dialog box*, page 78.

Consider this example and assume that the previous step has taken you to the  $f(i)$  function call (highlighted):

```
extern int g(int);
int f(int n)
{
    value = g(n-1) + g(n-2) + g(n-3);
    return value;
}
int main()
{
    ...
    f(i);
    value ++;
}
```



### Step Into

While stepping, you typically consider whether to step into a function and continue stepping inside the function or subroutine. The **Step Into** command takes you to the first step point within the subroutine  $g(n-1)$ :

```
extern int g(int);
int f(int n)
{
    value = g(n-1) + g(n-2) + g(n-3);
    return value;
}
```

The **Step Into** command executes to the next step point in the normal flow of control, regardless of whether it is in the same or another function.



### Step Over

The **Step Over** command executes to the next step point in the same function, without stopping inside called functions. The command would take you to the  $g(n-2)$  function call, which is not a statement on its own but part of the same statement as  $g(n-1)$ . Thus, you can skip uninteresting calls which are parts of statements and instead focus on critical parts:

```
extern int g(int);
int f(int n)
{
    value = g(n-1) + g(n-2) + g(n-3);
    return value;
}
```



### Next Statement

The **Next Statement** command executes directly to the next statement, in this case `return value`, allowing faster stepping:

```
extern int g(int);
int f(int n)
{
    value = g(n-1) + g(n-2) + g(n-3);
    return value;
}
```



### Step Out

When inside the function, you can—if you wish—use the **Step Out** command to step out of it before it reaches the exit. This will take you directly to the statement immediately after the function call:

```
extern int g(int);
int f(int n)
{
    value = g(n-1) + g(n-2) g(n-3);
    return value;
}
int main()
{
    ...
    f(i);
    value ++;
}
```

The possibility of stepping into an individual function that is part of a more complex statement is particularly useful when you use C code containing many nested function calls. It is also very useful for C++, which tends to have many implicit function calls, such as constructors, destructors, assignment operators, and other user-defined operators.

This detailed stepping can in some circumstances be either invaluable or unnecessarily slow. For this reason, you can also step only on statements, which means faster stepping.

### Single-stepping and flash memory in the C-SPY FET Debugger

When you use the FET Debugger driver, be aware that single-stepping over instructions that manipulate the flash memory might cause some unexpected side-effects.

Multiple internal machine cycles are required to clear and program the flash memory. When single-stepping over instructions that manipulate the flash memory, control is given back to C-SPY before these operations are complete. Consequently, C-SPY will

update its memory window with erroneous information. A workaround to this behavior is to follow the flash access instruction with a `NOP` instruction, and then step past the `NOP` before reviewing the effects of the flash access instruction.

## TROUBLESHOOTING SLOW STEPPING SPEED

If you find that stepping speed is slow, these troubleshooting tips might speed up stepping:

- If you are using a hardware debugger system, keep track of how many hardware breakpoints that are used and make sure some of them are left for stepping.  
Stepping in C-SPY is normally performed using breakpoints. When C-SPY performs a step command, a breakpoint is set on the next statement and the application executes until it reaches this breakpoint. If you are using a hardware debugger system, the number of hardware breakpoints—typically used for setting a stepping breakpoint in code that is located in flash/ROM memory—is limited. If you, for example, step into a `C switch` statement, breakpoints are set on each branch; this might consume several hardware breakpoints. If the number of available hardware breakpoints is exceeded, C-SPY switches into single stepping on assembly level, which can be very slow.  
For more information, see *Breakpoints in the C-SPY FET debugger driver*, page 106 and *Breakpoint consumers*, page 107.
- Disable trace data collection, using the **Enable/Disable** button in both the **Trace** and the **Function Profiling** windows. Trace data collection might slow down stepping because the collected trace data is processed after each step. Note that it is not sufficient to just close the corresponding windows to disable trace data collection.
- Choose to view only a limited selection of SFR registers. You can choose between two alternatives. Either type `#SFR_name` (where `SFR_name` reflects the name of the SFR you want to monitor) in the **Watch** window, or create your own filter for displaying a limited group of SFRs in the **Register** window. Displaying many SFR registers might slow down stepping because all registers must be read from the hardware after each step. See *Defining application-specific register groups*, page 141.
- Close the **Memory** and **Symbolic Memory** windows if they are open, because the visible memory must be read after each step and that might slow down stepping.
- Close any window that displays expressions such as **Watch**, **Live Watch**, **Locals**, **Statics** if it is open, because all these windows read memory after each step and that might slow down stepping.
- Close the **Stack** window if it is open. Choose **Tools>Options>Stack** and disable the **Enable graphical stack display and stack usage tracking** option if it is enabled.

- If possible, increase the communication speed between C-SPY and the target board/emulator.

## RUNNING THE APPLICATION

### Go

The **Go** command continues execution from the current position until a breakpoint or program exit is reached.

### Run to Cursor

The **Run to Cursor** command executes to the position in the source code where you have placed the cursor. The **Run to Cursor** command also works in the **Disassembly** window and in the **Call Stack** window.

## HIGHLIGHTING

At each stop, C-SPY highlights the corresponding C or C++ source or instruction with a green color, in the editor and the **Disassembly** window respectively. In addition, a green arrow appears in the editor window when you step on C or C++ source level, and in the **Disassembly** window when you step on disassembly level. This is determined by which of the windows is the active window. If none of the windows are active, it is determined by which of the windows was last active.

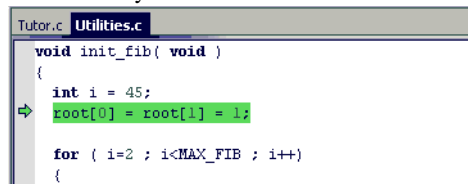

```
Tutor.c Utilities.c
void init_fib( void )
{
    int i = 45;
    ⇒ root[0] = root[1] = 1;
    for ( i=2 ; i<MAX_FIB ; i++)
    {
```

For simple statements without function calls, the whole statement is typically highlighted. When stopping at a statement with function calls, C-SPY highlights the first call because this illustrates more clearly what **Step Into** and **Step Over** would mean at that time.

Occasionally, you will notice that a statement in the source window is highlighted using a pale variant of the normal highlight color. This happens when the program counter is at an assembler instruction which is part of a source statement but not exactly at a step point. This is often the case when stepping in the **Disassembly** window. Only when the program counter is at the first instruction of the source statement, the ordinary highlight color is used.



## VIEWING THE CALL STACK

The compiler generates extensive call frame information. This allows C-SPY to show, without any runtime penalty, the complete function call chain at any time.



Typically, this is useful for two purposes:

- Determining in what context the current function has been called
- Tracing the origin of incorrect values in variables and in parameters, thus locating the function in the call chain where the problem occurred.

The **Call Stack** window shows a list of function calls, with the current function at the top. When you inspect a function in the call chain, the contents of all affected windows are updated to display the state of that particular call frame. This includes the editor, **Locals**, **Register**, **Watch**, and **Disassembly** windows. A function would normally not make use of all registers, so these registers might have undefined states and be displayed as dashes (---).

In the editor and **Disassembly** windows, a green highlight indicates the topmost, or current, call frame; a yellow highlight is used when inspecting other frames.

For your convenience, it is possible to select a function in the call stack and click the **Run to Cursor** command to execute to that function.

Assembler source code does not automatically contain any call frame information. To see the call chain also for your assembler modules, you can add the appropriate `CFI` assembler directives to the assembler source code. For more information, see the *IAR Assembler Reference Guide for MSP430*.

## TERMINAL INPUT AND OUTPUT

Sometimes you might have to debug constructions in your application that use `stdin` and `stdout` without an actual hardware device for input and output. The **Terminal I/O** window lets you enter input to your application, and display output from it. You can also direct terminal I/O to a file, using the **Terminal I/O Log Files** dialog box.



This facility is useful in two different contexts:

- If your application uses `stdin` and `stdout`
- For producing debug trace printouts.

For more information, see *Terminal I/O window*, page 73 and *Terminal I/O Log File dialog box*, page 74.

## DEBUG LOGGING

The **Debug Log** window displays debugger output, such as diagnostic messages, macro-generated output, and information about trace.



It can sometimes be convenient to log the information to a file where you can easily inspect it, see *Log File dialog box*, page 77. The two main advantages are:

- The file can be opened in another tool, for instance an editor, so you can navigate and search within the file for particularly interesting parts
- The file provides history about how you have controlled the execution, for instance, which breakpoints that have been triggered etc.

---

## Reference information on application execution

Reference information about:

- *Disassembly window*, page 67
- *Call Stack window*, page 71
- *Terminal I/O window*, page 73
- *Terminal I/O Log File dialog box*, page 74
- *Debug Log window*, page 75
- *Log File dialog box*, page 77
- *Report Assert dialog box*, page 78
- *Autostep settings dialog box*, page 78

See also Terminal I/O options in the *IDE Project Management and Building Guide*.

## Disassembly window

The C-SPY **Disassembly** window is available from the **View** menu.

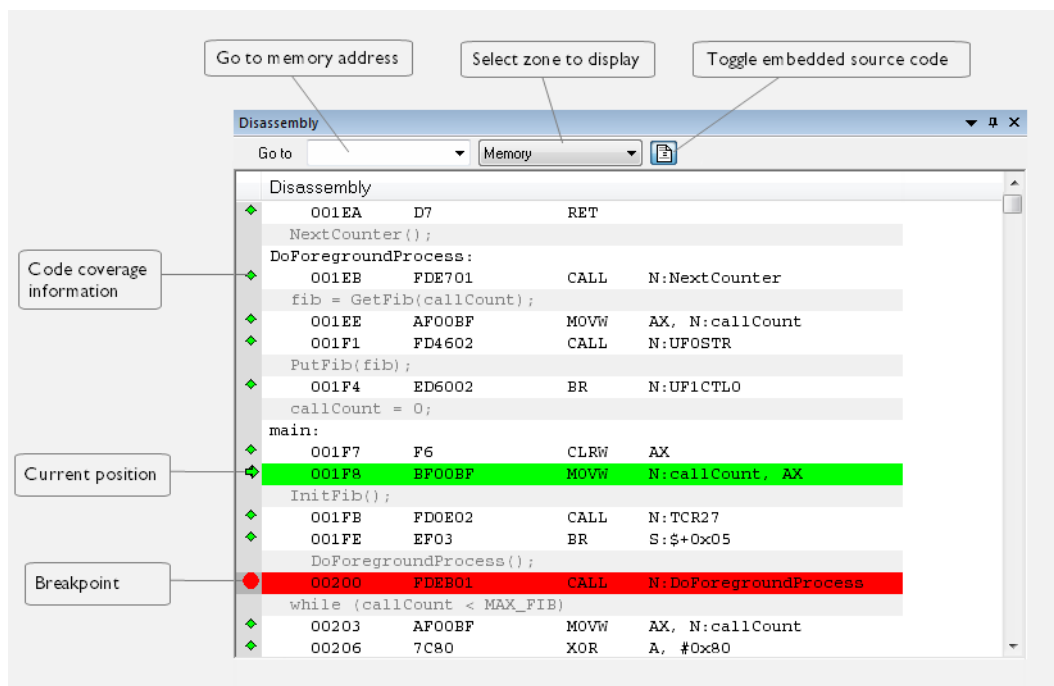

This figure reflects the C-SPY simulator.

This window shows the application being debugged as disassembled application code.

**To change the default color of the source code in the Disassembly window:**

- 1 Choose **Tools>Options>Debugger**.
- 2 Set the default color using the **Source code coloring in disassembly window** option.



To view the corresponding assembler code for a function, you can select it in the editor window and drag it to the **Disassembly** window.

See also *Source and disassembly mode debugging*, page 59.

### Requirements

None; this window is always available.

## Toolbar

The toolbar contains:

### Go to

The memory location or symbol you want to view.

### Zone

Selects a memory zone, see *C-SPY memory zones*, page 138.

### Toggle Mixed-Mode

Toggles between displaying only disassembled code or disassembled code together with the corresponding source code. Source code requires that the corresponding source file has been compiled with debug information

## Display area

The display area shows the disassembled application code.

This area contains these graphic elements:

Green highlight	Indicates the current position, that is the next assembler instruction to be executed. To move the cursor to any line in the <b>Disassembly</b> window, click the line. Alternatively, move the cursor using the navigation keys.
Yellow highlight	Indicates a position other than the current position, such as when navigating between frames in the <b>Call Stack</b> window or between items in the <b>Trace</b> window.
Red dot	Indicates a breakpoint. Double-click in the gray left-side margin of the window to set a breakpoint. For more information, see <i>Breakpoints</i> , page 103.
Green diamond	Indicates code that has been executed—that is, code coverage.

If instruction profiling has been enabled from the context menu, an extra column in the left-side margin appears with information about how many times each instruction has been executed.

## Context menu

This context menu is available:

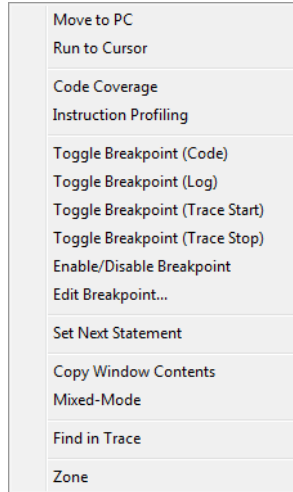

**Note:** The contents of this menu are dynamic, which means that the commands on the menu might depend on your product package.

These commands are available:

### Move to PC

Displays code at the current program counter location.

### Run to Cursor

Executes the application from the current position up to the line containing the cursor.

### Code Coverage

Displays a submenu that provides commands for controlling code coverage. This command is only enabled if the driver you are using supports it.

<b>Enable</b>	Toggles code coverage on or off.
<b>Show</b>	Toggles the display of code coverage on or off. Executed code is indicated by a green diamond.
<b>Clear</b>	Clears all code coverage information.

**Instruction Profiling**

Displays a submenu that provides commands for controlling instruction profiling. This command is only enabled if the driver you are using supports it.

<b>Enable</b>	Toggles instruction profiling on or off.
<b>Show</b>	Toggles the display of instruction profiling on or off. For each instruction, the left-side margin displays how many times the instruction has been executed.
<b>Clear</b>	Clears all instruction profiling information.

**Toggle Breakpoint (Code)**

Toggles a code breakpoint. Assembler instructions and any corresponding label at which code breakpoints have been set are highlighted in red. For more information, see *Code breakpoints dialog box*, page 118.

**Toggle Breakpoint (Log)**

Toggles a log breakpoint for trace printouts. Assembler instructions at which log breakpoints have been set are highlighted in red. For more information, see *Log breakpoints dialog box*, page 119.

**Toggle Breakpoint (Trace Start)**

Toggles a Trace Start breakpoint. When the breakpoint is triggered, the trace data collection starts. Note that this menu command is only available if the C-SPY driver you are using supports trace. For more information, see *Trace Start breakpoints dialog box*, page 185.

**Toggle Breakpoint (Trace Stop)**

Toggles a Trace Stop breakpoint. When the breakpoint is triggered, the trace data collection stops. Note that this menu command is only available if the C-SPY driver you are using supports trace. For more information, see *Trace Stop breakpoints dialog box*, page 186.

**Enable/Disable Breakpoint**

Enables and Disables a breakpoint. If there is more than one breakpoint at a specific line, all those breakpoints are affected by the **Enable/Disable** command.

**Edit Breakpoint**

Displays the breakpoint dialog box to let you edit the currently selected breakpoint. If there is more than one breakpoint on the selected line, a submenu is displayed that lists all available breakpoints on that line.

**Set Next Statement**

Sets the program counter to the address of the instruction at the insertion point.

### Copy Window Contents

Copies the selected contents of the **Disassembly** window to the clipboard.

### Mixed-Mode

Toggles between showing only disassembled code or disassembled code together with the corresponding source code. Source code requires that the corresponding source file has been compiled with debug information.

### Find in Trace

Searches the contents of the **Trace** window for occurrences of the given location—the position of the insertion point in the source code—and reports the result in the **Find in Trace** window. This menu command requires support for Trace in the C-SPY driver you are using, see *Differences between the C-SPY drivers*, page 39.

### Zone

Selects a memory zone, see *C-SPY memory zones*, page 138.

## Call Stack window

The **Call Stack** window is available from the **View** menu.

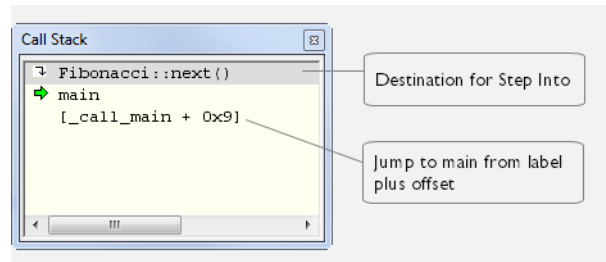

This window displays the C function call stack with the current function at the top. To inspect a function call, double-click it. C-SPY now focuses on that call frame instead.

If the next **Step Into** command would step to a function call, the name of the function is displayed in the gray bar at the top of the window. This is especially useful for implicit function calls, such as C++ constructors, destructors, and operators.

See also *Viewing the call stack*, page 65.

### Requirements

None; this window is always available.

## Display area

Each entry in the display area is formatted in one of these ways:

<code>function(values)***</code>	A C/C++ function with debug information.  Provided that <b>Show Arguments</b> is enabled, <i>values</i> is a list of the current values of the parameters, or empty if the function does not take any parameters.  ***, if present, indicates that the function has been inlined by the compiler. For information about function inlining, see the <i>IAR C/C++ Compiler User Guide for MSP430</i> .
<code>[label + offset]</code>	An assembler function, or a C/C++ function without debug information.
<code>&lt;exception_frame&gt;</code>	An interrupt.

## Context menu

This context menu is available:

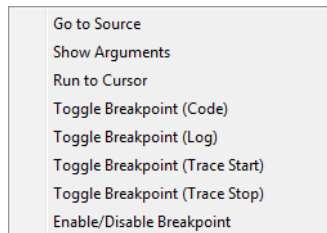

This figure reflects the C-SPY simulator.

These commands are available:

### Go to Source

Displays the selected function in the **Disassembly** or editor windows.

### Show Arguments

Shows function arguments.

### Run to Cursor

Executes until return to the function selected in the call stack.

### Toggle Breakpoint (Code)

Toggles a code breakpoint.



**Toggle Breakpoint (Conditional)**

Toggles a conditional breakpoint.

**Toggle Breakpoint (Advanced Trigger)**

Toggles an Advanced Trigger breakpoint.

**Toggle Breakpoint (Log)**

Toggles a log breakpoint.

**Toggle Breakpoint (Trace Start)**

Toggles a Trace Start breakpoint. When the breakpoint is triggered, trace data collection starts. Note that this menu command is only available if the C-SPY driver you are using supports it.

**Toggle Breakpoint (Trace Stop)**

Toggles a Trace Stop breakpoint. When the breakpoint is triggered, trace data collection stops. Note that this menu command is only available if the C-SPY driver you are using supports it.

**Enable/Disable Breakpoint**

Enables or disables the selected breakpoint

## Terminal I/O window

The **Terminal I/O** window is available from the **View** menu.

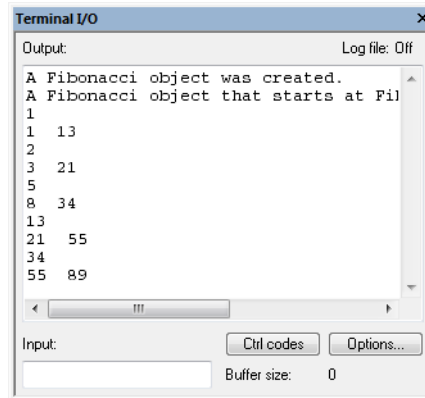

Use this window to enter input to your application, and display output from it.

**To use this window, you must:**

- I Link your application with the option **With I/O emulation modules**.

C-SPY will then direct `stdin`, `stdout` and `stderr` to this window. If the **Terminal I/O** window is closed, C-SPY will open it automatically when input is required, but not for output.

See also *Terminal input and output*, page 65.

### Requirements

None; this window is always available.

### Input

Type the text that you want to input to your application.

### Ctrl codes

Opens a menu for input of special characters, such as EOF (end of file) and NUL.

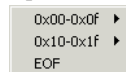

### Options

Opens the **IDE Options** dialog box where you can set options for terminal I/O. For reference information about the options available in this dialog box, see *Terminal I/O options* in *IDE Project Management and Building Guide*.

## Terminal I/O Log File dialog box

The **Terminal I/O Log File** dialog box is available by choosing **Debug>Logging>Set Terminal I/O Log File**.

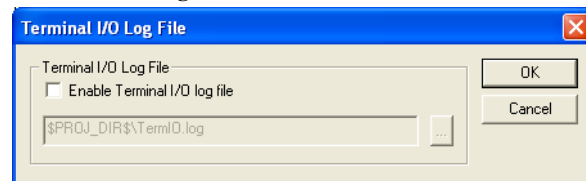

Use this dialog box to select a destination log file for terminal I/O from C-SPY.

See also *Terminal input and output*, page 65.

### Requirements

None; this dialog box is always available.

## Terminal IO Log Files

Controls the logging of terminal I/O. To enable logging of terminal I/O to a file, select **Enable Terminal IO log file** and specify a filename. The default filename extension is `log`. A browse button is available for your convenience.

## Debug Log window

The **Debug Log** window is available by choosing **View>Messages**.

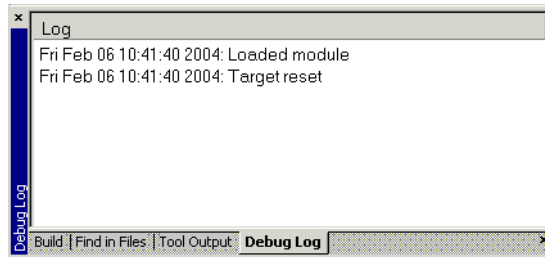

This window displays debugger output, such as diagnostic messages, macro-generated output, and information about trace. This output is only available during a debug session. When opened, this window is, by default, grouped together with the other message windows, see *IDE Project Management and Building Guide*.

Double-click any rows in one of the following formats to display the corresponding source code in the editor window:

```
<path> (<row>) :<message>
<path> (<row>, <column>) :<message>
```

See also *Debug logging*, page 65 and *Log File dialog box*, page 77.

## Requirements

None; this window is always available.

## Context menu

This context menu is available:

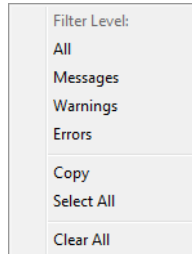

These commands are available:

### **All**

Shows all messages sent by the debugging tools and drivers.

### **Messages**

Shows all C-SPY messages.

### **Warnings**

Shows warnings and errors.

### **Errors**

Shows errors only.

### **Copy**

Copies the contents of the window.

### **Select All**

Selects the contents of the window.

### **Clear All**

Clears the contents of the window.

## Log File dialog box

The **Log File** dialog box is available by choosing **Debug>Logging>Set Log File**.

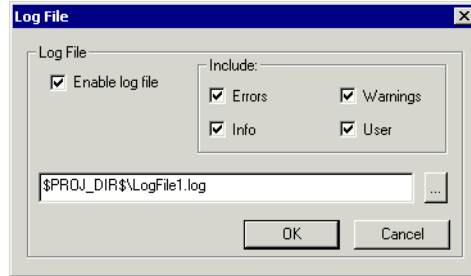

Use this dialog box to log output from C-SPY to a file.

### Requirements

None; this dialog box is always available.

### Enable Log file

Enables or disables logging to the file.

### Include

The information printed in the file is, by default, the same as the information listed in the Log window. Use the browse button, to override the default file and location of the log file (the default filename extension is `log`). To change the information logged, choose between:

#### Errors

C-SPY has failed to perform an operation.

#### Warnings

An error or omission of concern.

#### Info

Progress information about actions C-SPY has performed.

#### User

Messages from C-SPY macros, that is, your messages using the `__message` statement.

## Report Assert dialog box

The **Report Assert dialog box** appears if you have a call to the `assert` function in your application source code, and the assert condition is false. In this dialog box you can choose how to proceed.

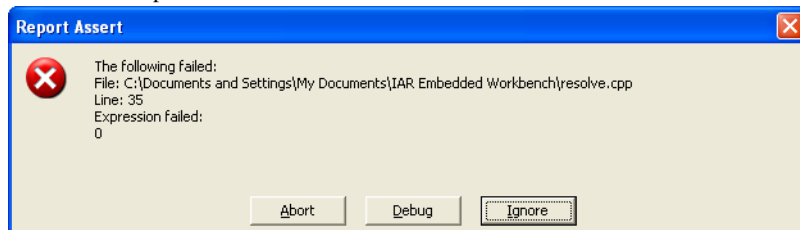

### Abort

The application stops executing and the runtime library function `abort`, which is part of your application on the target system, will be called. This means that the application itself terminates its execution.

### Debug

C-SPY stops the execution of the application and returns control to you.

### Ignore

The assertion is ignored and the application continues to execute.

## Autostep settings dialog box

The **Autostep settings** dialog box is available from the **Debug** menu.

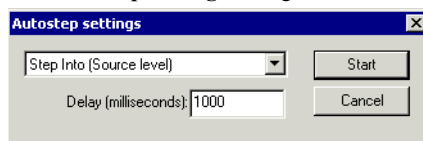

Use this dialog box to customize autostepping.

The drop-down menu lists the available step commands, see *Single stepping*, page 60.

### Requirements

None; this dialog box is always available.

### Delay

Specify the delay between each step in milliseconds.

# Variables and expressions

- Introduction to working with variables and expressions
- Working with variables and expressions
- Reference information on working with variables and expressions

---

## Introduction to working with variables and expressions

This section introduces different methods for looking at variables and introduces some related concepts.

These topics are covered:

- Briefly about working with variables and expressions
- C-SPY expressions
- Limitations on variable information.

### BRIEFLY ABOUT WORKING WITH VARIABLES AND EXPRESSIONS

There are several methods for looking at variables and calculating their values. These methods are suitable for basic debugging:

- **Tooltip watch**—in the editor window—provides the simplest way of viewing the value of a variable or more complex expressions. Just point at the variable with the mouse pointer. The value is displayed next to the variable.
- The **Auto** window displays a useful selection of variables and expressions in, or near, the current statement. The window is automatically updated when execution stops.
- The **Locals** window displays the local variables, that is, auto variables and function parameters for the active function. The window is automatically updated when execution stops.
- The **Watch** window allows you to monitor the values of C-SPY expressions and variables. The window is automatically updated when execution stops.
- The **Live Watch** window repeatedly samples and displays the values of expressions while your application is executing. Variables in the expressions must be statically located, such as global variables.
- The **Statics** window displays the values of variables with static storage duration. The window is automatically updated when execution stops.

- The **Macro Quicklaunch** window and the **Quick Watch** window give you precise control over when to evaluate an expression.
- The **Symbols** window displays all symbols with a static location, that is, C/C++ functions, assembler labels, and variables with static storage duration, including symbols from the runtime library.

These additional methods for looking at variables are suitable for more advanced analysis:

- The **Data Log** window and the **Data Log Summary** window display logs of accesses to up to four different memory locations you choose by setting data log breakpoints. Data logging can help you locate frequently accessed data. You can then consider whether you should place that data in more efficient memory.
- The **Data Sample** window displays samples for up to four different variables. You can also display the data samples as graphs in the **Sampled Graphs** window. By using data sampling, you will get an indication of the data value over a length of time. Because it is a sampled value, data sampling is best suited for slow-changing data.

For more information about these windows, see *The application timeline*, page 191.

## C-SPY EXPRESSIONS

C-SPY expressions can include any type of C expression, except for calls to functions. The following types of symbols can be used in expressions:

- C/C++ symbols
- Assembler symbols (register names and assembler labels)
- C-SPY macro functions
- C-SPY macro variables.

Expressions that are built with these types of symbols are called C-SPY expressions and there are several methods for monitoring these in C-SPY. Examples of valid C-SPY expressions are:

```
i + j
i = 42
myVar = cVar
cVar = myVar + 2
#asm_label
#R2
#PC
my_macro_func(19)
```

If you have a static variable with the same name declared in several different functions, use the notation `function::variable` to specify which variable to monitor.



## C/C++ symbols

C symbols are symbols that you have defined in the C source code of your application, for instance variables, constants, and functions (functions can be used as symbols but cannot be executed). C symbols can be referenced by their names. Note that C++ symbols might implicitly contain function calls which are not allowed in C-SPY symbols and expressions.

**Note:** Some attributes available in C/C++, like `volatile`, are not fully supported by C-SPY. For example, this line will not be accepted by C-SPY:

```
sizeof(unsigned char volatile __memattr *)
```

However, this line will be accepted:

```
sizeof(unsigned char __memattr *)
```

## Assembler symbols

Assembler symbols can be assembler labels or registers, for example the program counter, the stack pointer, or other CPU registers. If a device description file is used, all memory-mapped peripheral units, such as I/O ports, can also be used as assembler symbols in the same way as the CPU registers. See *Modifying a device description file*, page 48.

Assembler symbols can be used in C-SPY expressions if they are prefixed by #.

Example	What it does
#PC++	Increments the value of the program counter.
myVar = #SP	Assigns the current value of the stack pointer register to your C-SPY variable.
myVar = #label	Sets myVar to the value of an integer at the address of label.
myptr = &#label7	Sets myptr to an int * pointer pointing at label7.

Table 4: C-SPY assembler symbols expressions

In case of a name conflict between a hardware register and an assembler label, hardware registers have a higher precedence. To refer to an assembler label in such a case, you must enclose the label in back quotes ` (ASCII character 0x60). For example:

Example	What it does
#PC	Refers to the program counter.
#`PC`	Refers to the assembler label PC.

Table 5: Handling name conflicts between hardware registers and assembler labels

Which processor-specific symbols are available by default can be seen in the **Register** window, using the CPU Registers register group. See *Registers window*, page 159.

## C-SPY macro functions

Macro functions consist of C-SPY macro variable definitions and macro statements which are executed when the macro is called.

For information about C-SPY macro functions and how to use them, see *Briefly about the macro language*, page 306.

## C-SPY macro variables

Macro variables are defined and allocated outside your application, and can be used in a C-SPY expression. In case of a name conflict between a C symbol and a C-SPY macro variable, the C-SPY macro variable will have a higher precedence than the C variable. Assignments to a macro variable assign both its value and type.

For information about C-SPY macro variables and how to use them, see *Reference information on the macro language*, page 312.

## Using sizeof

According to standard C, there are two syntactical forms of `sizeof`:

```
sizeof(type)
sizeof expr
```

The former is for types and the latter for expressions.

**Note:** In C-SPY, do not use parentheses around an expression when you use the `sizeof` operator. For example, use `sizeof x+2` instead of `sizeof (x+2)`.

## LIMITATIONS ON VARIABLE INFORMATION

The value of a C variable is valid only on step points, that is, the first instruction of a statement and on function calls. This is indicated in the editor window with a bright green highlight color. In practice, the value of the variable is accessible and correct more often than that.

When the program counter is inside a statement, but not at a step point, the statement or part of the statement is highlighted with a pale variant of the ordinary highlight color.

## Effects of optimizations

The compiler is free to optimize the application software as much as possible, as long as the expected behavior remains. The optimization can affect the code so that debugging might be more difficult because it will be less clear how the generated code relates to the source code. Typically, using a high optimization level can affect the code in a way that will not allow you to view a value of a variable as expected.

Consider this example:

```
myFunction()
{
    int i = 42;
    ...
    x = computer(i); /* Here, the value of i is known to C-SPY */
    ...
}
```

From the point where the variable `i` is declared until it is actually used, the compiler does not need to waste stack or register space on it. The compiler can optimize the code, which means that C-SPY will not be able to display the value until it is actually used. If you try to view the value of a variable that is temporarily unavailable, C-SPY will display the text:

Unavailable

If you need full information about values of variables during your debugging session, you should make sure to use the lowest optimization level during compilation, that is, **None**.

---

## Working with variables and expressions

These tasks are covered:

- Using the windows related to variables and expressions
- Viewing assembler variables

See also *Analyzing your application's timeline*, page 193.

### USING THE WINDOWS RELATED TO VARIABLES AND EXPRESSIONS

Where applicable, you can add, modify, and remove expressions, and change the display format in the windows related to variables and expressions.

To add a value you can also click in the dotted rectangle and type the expression you want to examine. To modify the value of an expression, click the **Value** field and modify its content. To remove an expression, select it and press the Delete key.



For text that is too wide to fit in a column—in any of these windows, except the **Trace** window—and thus is truncated, just point at the text with the mouse pointer and tooltip information is displayed.

Right-click in any of the windows to access the context menu which contains additional commands. Convenient drag-and-drop between windows is supported, except for in the

**Locals** window, **Data logging** windows, and the **Quick Watch** window where it is not relevant.

## VIEWING ASSEMBLER VARIABLES

An assembler label does not convey any type information at all, which means C-SPY cannot easily display data located at that label without getting extra information. To view data conveniently, C-SPY by default treats all data located at assembler labels as variables of type `int`. However, in the **Watch**, **Live Watch**, and **Quick Watch** windows, you can select a different interpretation to better suit the declaration of the variables.

In this figure, you can see four variables in the **Watch** window and their corresponding declarations in the assembler source file to the left:

The screenshot shows the C-SPY interface with the assembler source file on the left and the Watch window on the right. The source file contains the following code:

```

NAME main

PUBLIC __iar_program_start

SECTION .intvec : CODE (2)
CODE32

__iar_program_start
B main

SECTION .text : CODE (2)

asmvar1: DC32 42
asmvar2: DC32 456
asmvar3: DC8 55
asmvar4: DC8 10

CODE32
main: NOP
B main
END

```

The Watch window displays the following data:

Expression	Value	Location	Type
asmvar1	42	0x00000080	int
asmvar2	456	0x00000084	int
asmvar3	55	0x00000088	<8-bit unsigned>
asmvar4	2615	0x0000008c	int

The context menu for the `asmvar4` row shows the following options:

- Default Format
- Binary Format
- Octal Format
- Decimal Format
- Hexadecimal Format
- Char Format
- Show As
  - As Is
  - 8-bit Signed
  - 8-bit Unsigned**
  - 16-bit Signed
  - 16-bit Unsigned
  - 32-bit Signed
  - 32-bit Unsigned
  - 64-bit Signed
  - 64-bit Unsigned
  - float
  - double
- Save to File...

Note that `asmvar4` is displayed as an `int`, although the original assembler declaration probably intended for it to be a single byte quantity. From the context menu you can make C-SPY display the variable as, for example, an 8-bit unsigned variable. This has already been specified for the `asmvar3` variable.

## Reference information on working with variables and expressions

Reference information about:

- *Auto window*, page 85
- *Locals window*, page 87
- *Watch window*, page 89
- *Live Watch window*, page 92
- *Statics window*, page 94
- *Quick Watch window*, page 97
- *Symbols window*, page 100
- *Resolve Symbol Ambiguity dialog box*, page 101

See also:

- *Reference information on trace*, page 180 for trace-related reference information
- *Macro Quicklaunch window*, page 361

### Auto window

The **Auto** window is available from the **View** menu.

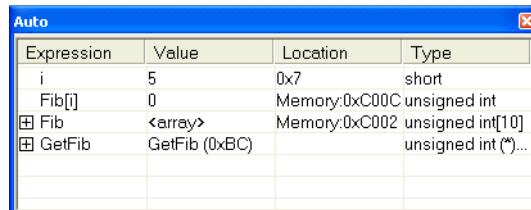

Expression	Value	Location	Type
i	5	0x7	short
Fib[i]	0	Memory:0xC00C	unsigned int
⊕ Fib	<array>	Memory:0xC002	unsigned int[10]
⊕ GetFib	GetFib (0xBC)		unsigned int (*)...

This window displays a useful selection of variables and expressions in, or near, the current statement. Every time execution in C-SPY stops, the values in the **Auto** window are recalculated. Values that have changed since the last stop are highlighted in red.

See also *Editing in C-SPY windows*, page 47.

### Requirements

None; this window is always available.

## Context menu

This context menu is available:

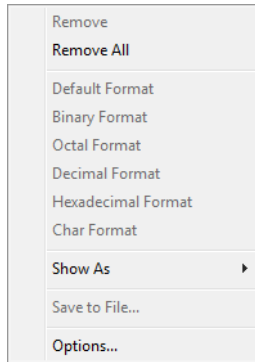

**Note:** The contents of this menu are dynamic and depend on which features that your combination of software and hardware supports. However, the list of menu commands below is complete and covers all possible commands.

These commands are available:

### Remove

Removes the selected expression from the window.

### Remove All

Removes all expressions listed in the window.

### Default Format, Binary Format, Octal Format, Decimal Format, Hexadecimal Format, Char Format

Changes the display format of expressions. The display format setting affects different types of expressions in different ways. Your selection of display format is saved between debug sessions. These commands are available if a selected line in the window contains a variable.

The display format setting affects different types of expressions in these ways:

Variables	The display setting affects only the selected variable, not other variables.
-----------	--

Array elements	The display setting affects the complete array, that is, the same display format is used for each array element.
----------------	--

Structure fields      All elements with the same definition—the same field name and C declaration type—are affected by the display setting.

### Show As

Displays a submenu that provides commands for changing the default type interpretation of variables. The commands on this submenu are mainly useful for assembler variables—data at assembler labels—because these are, by default, displayed as integers. For more information, see *Viewing assembler variables*, page 84.

### Options

Displays the **IDE Options** dialog box where you can set various options, for example the **Update interval** option. The default value of this option is 1000 milliseconds, which means the **Live Watch** window will be updated once every second during program execution.

### Save to File

Saves content to a file in a tab-separated format.

## Locals window

The **Locals** window is available from the **View** menu.

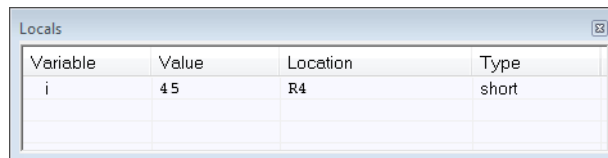

Variable	Value	Location	Type
i	45	R4	short

This window displays the local variables and parameters for the current function. Every time execution in C-SPY stops, the values in the window are recalculated. Values that have changed since the last stop are highlighted in red.

See also *Editing in C-SPY windows*, page 47.

### Requirements

None; this window is always available.

## Context menu

This context menu is available:

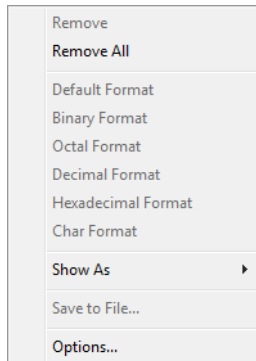

**Note:** The contents of this menu are dynamic and depend on which features that your combination of software and hardware supports. However, the list of menu commands below is complete and covers all possible commands.

These commands are available:

### Remove

Removes the selected expression from the window.

### Remove All

Removes all expressions listed in the window.

### Default Format, Binary Format, Octal Format, Decimal Format, Hexadecimal Format, Char Format

Changes the display format of expressions. The display format setting affects different types of expressions in different ways. Your selection of display format is saved between debug sessions. These commands are available if a selected line in the window contains a variable.

The display format setting affects different types of expressions in these ways:

Variables	The display setting affects only the selected variable, not other variables.
Array elements	The display setting affects the complete array, that is, the same display format is used for each array element.



Structure fields All elements with the same definition—the same field name and C declaration type—are affected by the display setting.

### Show As

Displays a submenu that provides commands for changing the default type interpretation of variables. The commands on this submenu are mainly useful for assembler variables—data at assembler labels—because these are, by default, displayed as integers. For more information, see *Viewing assembler variables*, page 84.

### Options

Displays the **IDE Options** dialog box where you can set various options, for example the **Update interval** option. The default value of this option is 1000 milliseconds, which means the **Live Watch** window will be updated once every second during program execution.

### Save to File

Saves content to a file in a tab-separated format.

## Watch window

The **Watch** window is available from the **View** menu.

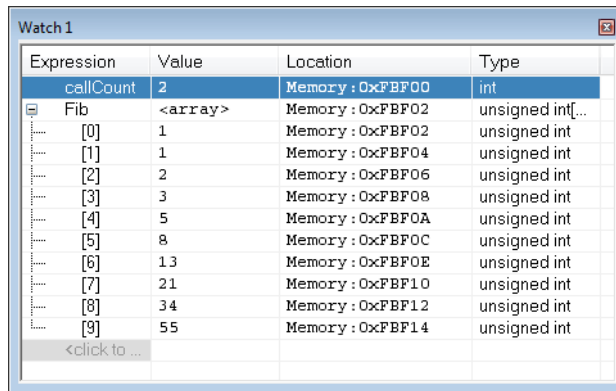

Expression	Value	Location	Type
callCount	2	Memory : 0xFBFF00	int
Fib	<array>	Memory : 0xFBFF02	unsigned int[...]
[0]	1	Memory : 0xFBFF02	unsigned int
[1]	1	Memory : 0xFBFF04	unsigned int
[2]	2	Memory : 0xFBFF06	unsigned int
[3]	3	Memory : 0xFBFF08	unsigned int
[4]	5	Memory : 0xFBFF0A	unsigned int
[5]	8	Memory : 0xFBFF0C	unsigned int
[6]	13	Memory : 0xFBFF0E	unsigned int
[7]	21	Memory : 0xFBFF10	unsigned int
[8]	34	Memory : 0xFBFF12	unsigned int
[9]	55	Memory : 0xFBFF14	unsigned int
<click to ...			

Use this window to monitor the values of C-SPY expressions or variables. You can open up to four instances of this window, where you can view, add, modify, and remove expressions. Tree structures of arrays, structs, and unions are expandable, which means that you can study each item of these.

Every time execution in C-SPY stops, the values in the **Watch** window are recalculated. Values that have changed since the last stop are highlighted in red.



Be aware that expanding very huge arrays can cause an out-of-memory crash. To avoid this, expansion is automatically performed in steps of 5000 elements.

See also *Editing in C-SPY windows*, page 47.

## Requirements

None; this window is always available.

## Context menu

This context menu is available:

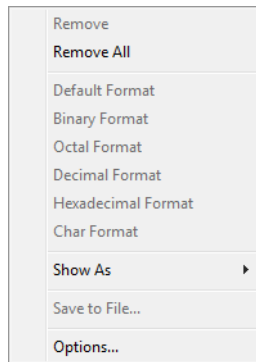

**Note:** The contents of this menu are dynamic and depend on which features that your combination of software and hardware supports. However, the list of menu commands below is complete and covers all possible commands.

These commands are available:

### Remove

Removes the selected expression from the window.

### Remove All

Removes all expressions listed in the window.

**Default Format,  
Binary Format,  
Octal Format,  
Decimal Format,  
Hexadecimal Format,  
Char Format**

Changes the display format of expressions. The display format setting affects different types of expressions in different ways. Your selection of display format is saved between debug sessions. These commands are available if a selected line in the window contains a variable.

The display format setting affects different types of expressions in these ways:

Variables	The display setting affects only the selected variable, not other variables.
Array elements	The display setting affects the complete array, that is, the same display format is used for each array element.
Structure fields	All elements with the same definition—the same field name and C declaration type—are affected by the display setting.

**Show As**

Displays a submenu that provides commands for changing the default type interpretation of variables. The commands on this submenu are mainly useful for assembler variables—data at assembler labels—because these are, by default, displayed as integers. For more information, see *Viewing assembler variables*, page 84.

**Options**

Displays the **IDE Options** dialog box where you can set various options, for example the **Update interval** option. The default value of this option is 1000 milliseconds, which means the **Live Watch** window will be updated once every second during program execution.

**Save to File**

Saves content to a file in a tab-separated format.

## Live Watch window

The **Live Watch** window is available from the **View** menu.

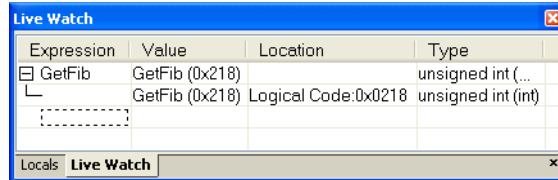

This window repeatedly samples and displays the value of expressions while your application is executing. Variables in the expressions must be statically located, such as global variables.

See also *Editing in C-SPY windows*, page 47.

### Requirements

The C-SPY simulator.

### Display area

This area contains these columns:

#### Expression

The name of the variable. The base name of the variable is followed by the full name, which includes module, class, or function scope. This column is not editable.

#### Value

The value of the variable. Values that have changed are highlighted in red.

Dragging text or a variable from another window and dropping it on the **Value** column will assign a new value to the variable in that row.

This column is editable.

#### Location

The location in memory where this variable is stored.

#### Type

The data type of the variable.

## Context menu

This context menu is available:

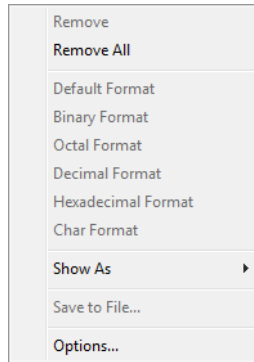

**Note:** The contents of this menu are dynamic and depend on which features that your combination of software and hardware supports. However, the list of menu commands below is complete and covers all possible commands.

These commands are available:

### **Remove**

Removes the selected expression from the window.

### **Remove All**

Removes all expressions listed in the window.

### **Default Format,**

### **Binary Format,**

### **Octal Format,**

### **Decimal Format,**

### **Hexadecimal Format,**

### **Char Format**

Changes the display format of expressions. The display format setting affects different types of expressions in different ways. Your selection of display format is saved between debug sessions. These commands are available if a selected line in the window contains a variable.

The display format setting affects different types of expressions in these ways:

Variables	The display setting affects only the selected variable, not other variables.
-----------	--

Array elements	The display setting affects the complete array, that is, the same display format is used for each array element.
----------------	--

Structure fields All elements with the same definition—the same field name and C declaration type—are affected by the display setting.

### Show As

Displays a submenu that provides commands for changing the default type interpretation of variables. The commands on this submenu are mainly useful for assembler variables—data at assembler labels—because these are, by default, displayed as integers. For more information, see *Viewing assembler variables*, page 84.

### Options

Displays the **IDE Options** dialog box where you can set various options, for example the **Update interval** option. The default value of this option is 1000 milliseconds, which means the **Live Watch** window will be updated once every second during program execution.

### Save to File

Saves content to a file in a tab-separated format.

## Statics window

The **Statics** window is available from the **View** menu.

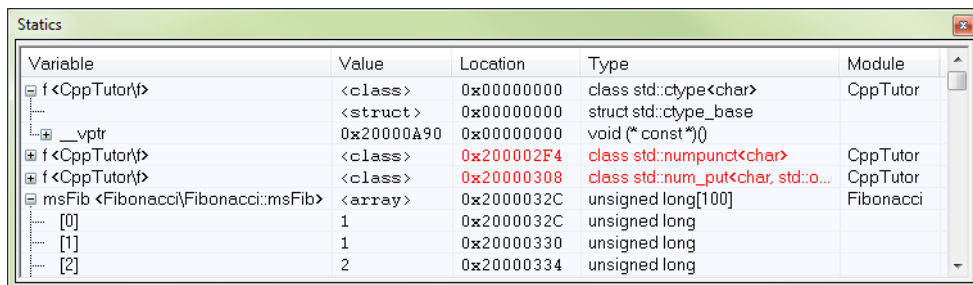

Variable	Value	Location	Type	Module
f <CppTutor\>	<class>	0x00000000	class std::ctype<char>	CppTutor
.....	<struct>	0x00000000	struct std::ctype_base	
.....	0x20000A90	0x00000000	void (* const*)()	
.....	.....	.....	.....	.....
f <CppTutor\>	<class>	0x200002F4	class std::num_punct<char>	CppTutor
f <CppTutor\>	<class>	0x20000308	class std::num_put<char, std::o...	CppTutor
msFib <Fibonacci\Fibonacci:msFib>	<array>	0x2000032C	unsigned long[100]	Fibonacci
..... [0]	1	0x2000032C	unsigned long	
..... [1]	1	0x20000330	unsigned long	
..... [2]	2	0x20000334	unsigned long	

This window displays the values of variables with static storage duration that you have selected. Typically, that is variables with file scope but it can also be static variables in functions and classes. Note that `volatile` declared variables with static storage duration will not be displayed.

Every time execution in C-SPY stops, the values in the **Statics** window are recalculated. Values that have changed since the last stop are highlighted in red.

Click any column header (except for **Value**) to sort on that column.

See also *Editing in C-SPY windows*, page 47.

### To select variables to monitor:

- 1 In the window, right-click and choose **Select statics** from the context menu. The window now lists all variables with static storage duration.
- 2 Either individually select the variables you want to display, or choose one of the **Select** commands from the context menu.
- 3 When you have made your selections, choose **Select statics** from the context menu to toggle back to normal display mode.

### Requirements

None; this window is always available.

### Display area

This area contains these columns:

#### Expression

The name of the variable. The base name of the variable is followed by the full name, which includes module, class, or function scope. This column is not editable.

#### Value

The value of the variable. Values that have changed are highlighted in red.

Dragging text or a variable from another window and dropping it on the **Value** column will assign a new value to the variable in that row.

This column is editable.

#### Location

The location in memory where this variable is stored.

#### Type

The data type of the variable.

#### Module

The module of the variable.

## Context menu

This context menu is available:

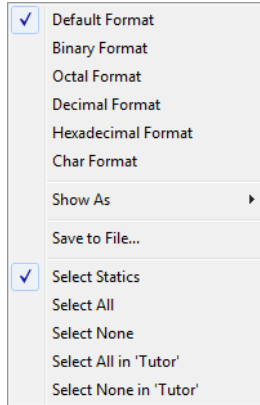

These commands are available:

### **Default Format, Binary Format, Octal Format, Decimal Format, Hexadecimal Format, Char Format**

Changes the display format of expressions. The display format setting affects different types of expressions in different ways. Your selection of display format is saved between debug sessions. These commands are available if a selected line in the window contains a variable.

The display format setting affects different types of expressions in these ways:

Variables	The display setting affects only the selected variable, not other variables.
Array elements	The display setting affects the complete array, that is, the same display format is used for each array element.
Structure fields	All elements with the same definition—the same field name and C declaration type—are affected by the display setting.

### **Save to File**

Saves the content of the **Statics** window to a log file.



**Select Statics**

Selects all variables with static storage duration; this command also enables all **Select** commands below. Select the variables you want to monitor. When you have made your selections, select this menu command again to toggle back to normal display mode.

**Select All**

Selects all variables.

**Select None**

Deselects all variables.

**Select All in *module***

Selects all variables in the selected module.

**Select None in *module***

Deselects all variables in the selected module.

## Quick Watch window

The **Quick Watch** window is available from the **View** menu and from the context menu in the editor window.

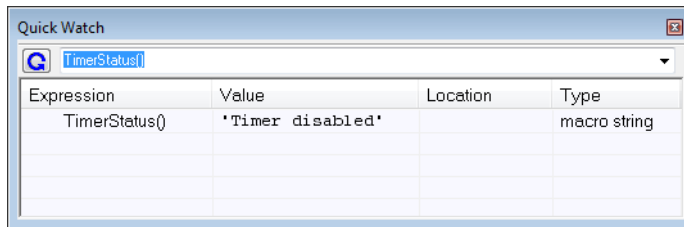

Use this window to watch the value of a variable or expression and evaluate expressions at a specific point in time.

In contrast to the **Watch** window, the **Quick Watch** window gives you precise control over when to evaluate the expression. For single variables this might not be necessary, but for expressions with possible side effects, such as assignments and C-SPY macro functions, it allows you to perform evaluations under controlled conditions.

See also *Editing in C-SPY windows*, page 47.

**To evaluate an expression:**

- 1 In the editor window, right-click on the expression you want to examine and choose **Quick Watch** from the context menu that appears.
- 2 The expression will automatically appear in the **Quick Watch** window.

Alternatively:

**3** In the **Quick Watch** window, type the expression you want to examine in the **Expressions** text box.



**4** Click the **Recalculate** button to calculate the value of the expression.

For an example, see *Using C-SPY macros*, page 307.

### Requirements

None; this window is always available.

### Context menu

This context menu is available:

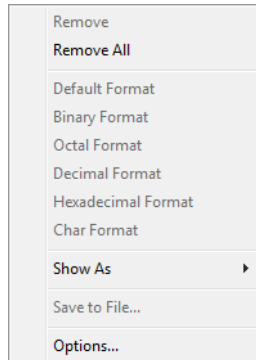

**Note:** The contents of this menu are dynamic and depend on which features that your combination of software and hardware supports. However, the list of menu commands below is complete and covers all possible commands.

These commands are available:

#### **Remove**

Removes the selected expression from the window.

#### **Remove All**

Removes all expressions listed in the window.

**Default Format,  
Binary Format,  
Octal Format,  
Decimal Format,  
Hexadecimal Format,  
Char Format**

Changes the display format of expressions. The display format setting affects different types of expressions in different ways. Your selection of display format is saved between debug sessions. These commands are available if a selected line in the window contains a variable.

The display format setting affects different types of expressions in these ways:

Variables	The display setting affects only the selected variable, not other variables.
Array elements	The display setting affects the complete array, that is, the same display format is used for each array element.
Structure fields	All elements with the same definition—the same field name and C declaration type—are affected by the display setting.

**Show As**

Displays a submenu that provides commands for changing the default type interpretation of variables. The commands on this submenu are mainly useful for assembler variables—data at assembler labels—because these are, by default, displayed as integers. For more information, see *Viewing assembler variables*, page 84.

**Options**

Displays the **IDE Options** dialog box where you can set various options, for example the **Update interval** option. The default value of this option is 1000 milliseconds, which means the **Live Watch** window will be updated once every second during program execution.

**Save to File**

Saves content to a file in a tab-separated format.

## Symbols window

The **Symbols** window is available from the **View** menu after you have enabled the Symbols plugin module.

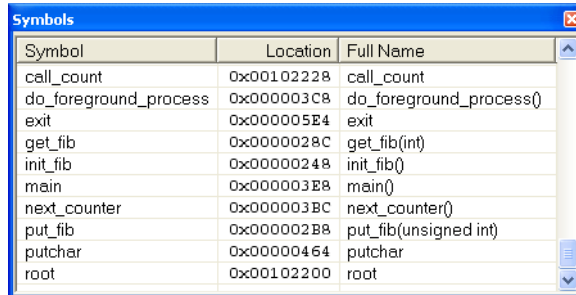

Symbol	Location	Full Name
call_count	0x00102228	call_count
do_foreground_process	0x000003C8	do_foreground_process()
exit	0x000005E4	exit
get_fib	0x0000028C	get_fib(int)
init_fib	0x00000248	init_fib()
main	0x000003E8	main()
next_counter	0x000003BC	next_counter()
put_fib	0x000002B8	put_fib(unsigned int)
putchar	0x00000464	putchar
root	0x00102200	root

This window displays all symbols with a static location, that is, C/C++ functions, assembler labels, and variables with static storage duration, including symbols from the runtime library.

To enable the Symbols plugin module, choose **Project>Options>Debugger>Select plugins to load>Symbols**.

### Requirements

None; this window is always available.

### Display area

This area contains these columns:

#### Symbol

The symbol name.

#### Location

The memory address.

#### Full name

The symbol name; often the same as the contents of the Symbol column but differs for example for C++ member functions.

Click the column headers to sort the list by symbol name, location, or full name.

## Context menu

This context menu is available:



These commands are available:

### Functions

Toggles the display of function symbols on or off in the list.

### Variables

Toggles the display of variables on or off in the list.

### Labels

Toggles the display of labels on or off in the list.

## Resolve Symbol Ambiguity dialog box

The **Resolve Symbol Ambiguity** dialog box appears, for example, when you specify a symbol in the **Disassembly** window to go to, and there are several instances of the same symbol due to templates or function overloading.

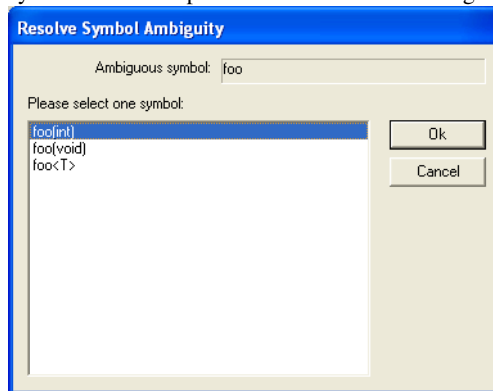

### Requirements

None; this window is always available.

### Ambiguous symbol

Indicates which symbol that is ambiguous.

**Please select one symbol**

A list of possible matches for the ambiguous symbol. Select the one you want to use.

# Breakpoints

- Introduction to setting and using breakpoints
- Setting breakpoints
- Reference information on breakpoints

---

## Introduction to setting and using breakpoints

These topics are covered:

- Reasons for using breakpoints
- Briefly about setting breakpoints
- Breakpoint types
- Breakpoint icons
- Breakpoints in the C-SPY simulator
- Breakpoint consumers

### REASONS FOR USING BREAKPOINTS

C-SPY® lets you set various types of breakpoints in the application you are debugging, allowing you to stop at locations of particular interest. You can set a breakpoint at a *code* location to investigate whether your program logic is correct, or to get trace printouts. In addition to code breakpoints, and depending on what C-SPY driver you are using, additional breakpoint types might be available. For example, you might be able to set a *data* breakpoint, to investigate how and when the data changes.

You can let the execution stop under certain *conditions*, which you specify. You can also let the breakpoint trigger a *side effect*, for instance executing a C-SPY macro function, by transparently stopping the execution and then resuming. The macro function can be defined to perform a wide variety of actions, for instance, simulating hardware behavior.

All these possibilities provide you with a flexible tool for investigating the status of your application.

### BRIEFLY ABOUT SETTING BREAKPOINTS

You can set breakpoints in many various ways, allowing for different levels of interaction, precision, timing, and automation. All the breakpoints you define will appear in the Breakpoints window. From this window you can conveniently view all breakpoints, enable and disable breakpoints, and open a dialog box for defining new

breakpoints. The **Breakpoint Usage** window also lists all internally used breakpoints, see *Breakpoint consumers*, page 107.

Breakpoints are set with a higher precision than single lines, using the same mechanism as when stepping; for more information about the precision, see *Single stepping*, page 60.

You can set breakpoints while you edit your code even if no debug session is active. The breakpoints will then be validated when the debug session starts. Breakpoints are preserved between debug sessions.

**Note:** For most hardware debugger systems it is only possible to set breakpoints when the application is not executing.

## BREAKPOINT TYPES

Depending on the C-SPY driver you are using, C-SPY supports different types of breakpoints.

### Code breakpoints

Code breakpoints are used for code locations to investigate whether your program logic is correct or to get trace printouts. Code breakpoints are triggered when an instruction is fetched from the specified location. If you have set the breakpoint on a specific machine instruction, the breakpoint will be triggered and the execution will stop, before the instruction is executed.

For the C-SPY FET Debugger driver, a code breakpoint can be either a hardware or a software breakpoint.

### Log breakpoints

Log breakpoints provide a convenient way to add trace printouts without having to add any code to your application source code. Log breakpoints are triggered when an instruction is fetched from the specified location. If you have set the breakpoint on a specific machine instruction, the breakpoint will be triggered and the execution will temporarily stop and print the specified message in the C-SPY **Debug Log** window.

### Trace Start and Stop breakpoints

Trace Start and Stop breakpoints start and stop trace data collection—a convenient way to analyze instructions between two execution points.

### Data breakpoints

Data breakpoints are primarily useful for variables that have a fixed address in memory. If you set a breakpoint on an accessible local variable, the breakpoint is set on the



corresponding memory location. The validity of this location is only guaranteed for small parts of the code. Data breakpoints are triggered when data is accessed at the specified location. The execution will usually stop directly after the instruction that accessed the data has been executed.

### Data Log breakpoints

Data log breakpoints are triggered when a specified memory address is accessed. A log entry is written in the **Data Log** window for each access. Data logs can also be displayed on the Data Log graph in the **Timeline** window, if that window is enabled.

You can set data log breakpoints using the **Breakpoints** window, the **Memory** window, and the editor window.

Using a single instruction, the microcontroller can only access values that are two bytes or less. If you specify a data log breakpoint on a memory location that cannot be accessed by one instruction, for example a `double` or a too large area in the **Memory** window, the result might not be what you intended.

### Immediate breakpoints

The C-SPY Simulator lets you set *immediate* breakpoints, which will halt instruction execution only temporarily. This allows a C-SPY macro function to be called when the simulated processor is about to read data from a location or immediately after it has written data. Instruction execution will resume after the action.

This type of breakpoint is useful for simulating memory-mapped devices of various kinds (for instance serial ports and timers). When the simulated processor reads from a memory-mapped location, a C-SPY macro function can intervene and supply appropriate data. Conversely, when the simulated processor writes to a memory-mapped location, a C-SPY macro function can act on the value that was written.

### Range breakpoints

*Range breakpoints* can be set on a data or an address range, and the action can be specified to occur on an access inside or outside the specified range. These breakpoints are only available if you are using a device that supports the Enhanced Emulation Module at the required level.

### Advanced trigger breakpoints

*Advanced trigger breakpoints* can be set with various operators on the address bus, the data bus, or on a register, to be triggered by a certain kind of access. These breakpoints are only available if you are using a device that supports the Enhanced Emulation Module at the required level.

## Conditional breakpoints

*Conditional breakpoints* can be set with various operators on the address bus, the data bus, or on a register, to be triggered by a certain kind of access. You can also specify a conditional value. These breakpoints are only available if you are using a device that supports the Enhanced Emulation Module at the required level.

## BREAKPOINT ICONS

A breakpoint is marked with an icon in the left margin of the editor window, and the icon varies with the type of breakpoint:

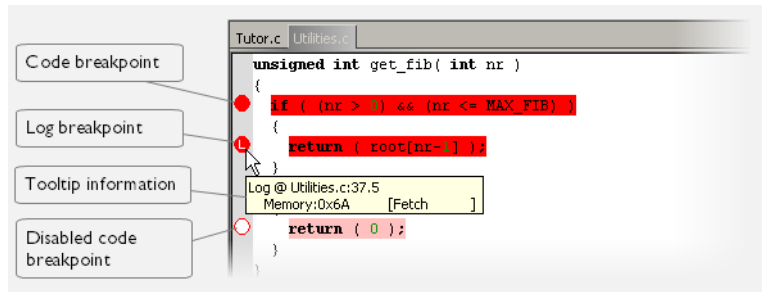

If the breakpoint icon does not appear, make sure the option **Show bookmarks** is selected, see Editor options in the *IDE Project Management and Building Guide*.



Just point at the breakpoint icon with the mouse pointer to get detailed tooltip information about all breakpoints set on the same location. The first row gives user breakpoint information, the following rows describe the physical breakpoints used for implementing the user breakpoint. The latter information can also be seen in the **Breakpoint Usage** window.

**Note:** The breakpoint icons might look different for the C-SPY driver you are using.

## BREAKPOINTS IN THE C-SPY SIMULATOR

The C-SPY simulator supports all breakpoint types and you can set an unlimited amount of breakpoints.

## BREAKPOINTS IN THE C-SPY FET DEBUGGER DRIVER

Using the C-SPY drivers for the C-SPY FET debugger, you can set *code* breakpoints. If you are using a device that supports the *Enhanced Emulation Module* at the required level, you also have access to an extended breakpoint system with support for:

- breakpoints on addresses, data, and registers

- defining which type of access that should trigger the breakpoint: read, write, or fetch
- setting conditional breakpoints
- triggering different actions: stopping the execution, or starting the state storage module
- emulated breakpoints.

The Enhanced Emulation Module (at the required level) also gives you access to the sequencer module which is a state machine that uses breakpoints for triggering new states.

### Hardware breakpoints

To set breakpoints, the C-SPY FET Debugger uses the hardware breakpoints available on the device. The number of hardware breakpoints is limited, and when all hardware breakpoints have been used, C-SPY can use software breakpoints.

For information about the number of available hardware breakpoints for each device, see the release notes or the hardware documentation.

### Software breakpoints

There are two types of software breakpoints: *virtual breakpoints* and *emulated breakpoints*. See , for information about how to specify which type to use.

When virtual breakpoints are used, C-SPY is forced into single-step mode after all hardware breakpoints have been used. However, if your device supports the Enhanced Emulation Module at the required level, you can use emulated breakpoints for access to an unlimited number of breakpoints.

When emulated breakpoints are used, the instruction where the breakpoint is set will be replaced by a special instruction that the debugger recognizes. When the debugger encounters such an instruction, it stops. This mechanism uses one hardware breakpoint to emulate an unlimited number of breakpoints.

To prevent the debugger from executing in single-step mode if you do not use emulated software breakpoints, you can disable the use of virtual breakpoints and—in the CLIB runtime environment—fine-tune the use of breakpoint consumers. This will increase the performance of the debugger, but you will only have access to the available number of hardware breakpoints. For information about the breakpoint consumers of the debugger system, see *Breakpoint consumers*, page 107.

## BREAKPOINT CONSUMERS

A debugger system includes several consumers of breakpoints.

## User breakpoints

The breakpoints you define in the breakpoint dialog box or by toggling breakpoints in the editor window often consume one physical breakpoint each, but this can vary greatly. Some user breakpoints consume several physical breakpoints and conversely, several user breakpoints can share one physical breakpoint. User breakpoints are displayed in the same way both in the **Breakpoint Usage** window and in the **Breakpoints** window, for example **Data @[R] callCount**.

## C-SPY itself

C-SPY itself also consumes breakpoints. C-SPY will set a breakpoint if:

- The debugger option **Run to** has been selected, and any step command is used. These are temporary breakpoints which are only set during a debug session. This means that they are not visible in the Breakpoints window.
- The linker option **With I/O emulation modules** has been selected.

In the DLIB runtime environment, C-SPY will set a system breakpoint on the `__DebugBreak` label.

In the CLIB runtime environment, C-SPY will set a breakpoint if:

- the library functions `putchar` and `getchar` are used (low-level routines used by functions like `printf` and `scanf`)
- the application has an `exit` label.

You can disable the setting of system breakpoints on the `putchar` and `getchar` functions and on the `exit` label; see *Breakpoints*, page 398.

When the **Run to** option is selected and all hardware breakpoints have already been used, a virtual breakpoint will be set even if you have deselected the **Use virtual breakpoints** option. When you start the debugger under these conditions, C-SPY will prompt you to choose whether you want to execute in single-step mode or stop at the first instruction.

These types of breakpoint consumers are displayed in the **Breakpoint Usage** window, for example, **C-SPY Terminal I/O & libsupport module**.

## C-SPY plugin modules

For example, modules for real-time operating systems can consume additional breakpoints. Specifically, by default, the **Stack** window consumes one physical breakpoint.

### To disable the breakpoint used by the Stack window:

- 1 Choose **Tools>Options>Stack**.
- 2 Deselect the **Stack pointer(s) not valid until program reaches: label** option.

To disable the **Stack** window entirely, choose **Tools>Options>Stack** and make sure all options are deselected.

## Setting breakpoints

These tasks are covered:

- Various ways to set a breakpoint
- Toggling a simple code breakpoint
- Setting breakpoints using the dialog box
- Setting a data breakpoint in the Memory window
- Setting breakpoints using system macros
- Useful breakpoint hints.

### VARIOUS WAYS TO SET A BREAKPOINT

You can set a breakpoint in various ways:

- Toggling a simple code breakpoint.
- Using the **New Breakpoints** dialog box and the **Edit Breakpoints** dialog box available from the context menus in the editor window, **Breakpoints** window, and in the **Disassembly** window. The dialog boxes give you access to all breakpoint options.
- Setting a data breakpoint on a memory area directly in the **Memory** window.
- Using predefined system macros for setting breakpoints, which allows automation.

The different methods offer different levels of simplicity, complexity, and automation.

### TOGGLING A SIMPLE CODE BREAKPOINT

Toggling a code breakpoint is a quick method of setting a breakpoint. The following methods are available both in the editor window and in the **Disassembly** window:

- Click in the gray left-side margin of the window
- Place the insertion point in the C source statement or assembler instruction where you want the breakpoint, and click the **Toggle Breakpoint** button in the toolbar
- Choose **Edit>Toggle Breakpoint**
- Right-click and choose **Toggle Breakpoint** from the context menu.



### SETTING BREAKPOINTS USING THE DIALOG BOX

The advantage of using a breakpoint dialog box is that it provides you with a graphical interface where you can interactively fine-tune the characteristics of the breakpoints.

You can set the options and quickly test whether the breakpoint works according to your intentions.

All breakpoints you define using a breakpoint dialog box are preserved between debug sessions.

You can open the dialog box from the context menu available in the editor window, Breakpoints window, and in the **Disassembly** window.

### To set a new breakpoint:

- 1 Choose **View>Breakpoints** to open the **Breakpoints** window.
- 2 In the **Breakpoints** window, right-click, and choose **New Breakpoint** from the context menu.
- 3 On the submenu, choose the breakpoint type you want to set.  
Depending on the C-SPY driver you are using, different breakpoint types are available.
- 4 In the breakpoint dialog box that appears, specify the breakpoint settings and click **OK**.

The breakpoint is displayed in the **Breakpoints** window.

### To modify an existing breakpoint:

- 1 In the **Breakpoints** window, editor window, or in the **Disassembly** window, select the breakpoint you want to modify and right-click to open the context menu.

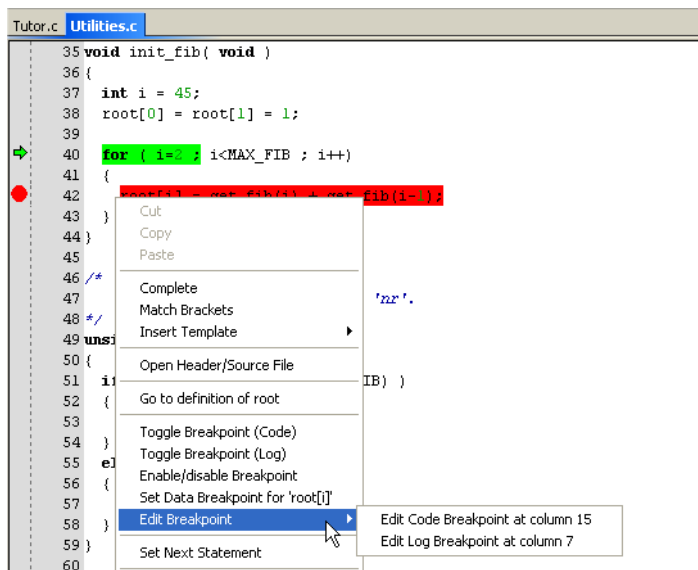

If there are several breakpoints on the same source code line, the breakpoints will be listed on a submenu.

- 2 On the context menu, choose the appropriate command.
- 3 In the breakpoint dialog box that appears, specify the breakpoint settings and click **OK**.

The breakpoint is displayed in the **Breakpoints** window.

## SETTING A DATA BREAKPOINT IN THE MEMORY WINDOW

You can set breakpoints directly on a memory location in the **Memory** window.

Right-click in the window and choose the breakpoint command from the context menu that appears. To set the breakpoint on a range, select a portion of the memory contents.

The breakpoint is not highlighted in the **Memory** window; instead, you can see, edit, and remove it using the **Breakpoints** window, which is available from the **View** menu. The breakpoints you set in the **Memory** window will be triggered for both read and write accesses. All breakpoints defined in this window are preserved between debug sessions.

**Note:** Setting breakpoints directly in the **Memory** window is only possible if the driver you use supports this.

## SETTING BREAKPOINTS USING SYSTEM MACROS

You can set breakpoints not only in the breakpoint dialog box but also by using built-in C-SPY system macros. When you use system macros for setting breakpoints, the breakpoint characteristics are specified as macro parameters.

Macros are useful when you have already specified your breakpoints so that they fully meet your requirements. You can define your breakpoints in a macro file, using built-in system macros, and execute the file at C-SPY startup. The breakpoints will then be set automatically each time you start C-SPY. Another advantage is that the debug session will be documented, and that several engineers involved in the development project can share the macro files.

**Note:** If you use system macros for setting breakpoints, you can still view and modify them in the Breakpoints window. In contrast to using the dialog box for defining breakpoints, all breakpoints that are defined using system macros are removed when you exit the debug session.

These breakpoint macros are available:

<b>C-SPY macro for breakpoints</b>	<b>Simulator</b>	<b>FET Debugger</b>
<code>__setAdvancedTriggerBreak</code>	—	Yes
<code>__setCodeBreak</code>	Yes	Yes
<code>__setConditionalBreak</code>	—	Yes
<code>__setDataBreak</code>	Yes	—
<code>__setLogBreak</code>	Yes	Yes
<code>__setRangeBreak</code>	—	Yes
<code>__setDataLogBreak</code>	Yes	—
<code>__setSimBreak</code>	Yes	—
<code>__setTraceStartBreak</code>	Yes	—
<code>__setTraceStopBreak</code>	Yes	—
<code>__clearBreak</code>	Yes	Yes

Table 6: C-SPY macros for breakpoints

For information about each breakpoint macro, see *Reference information on C-SPY system macros*, page 319.

### Setting breakpoints at C-SPY startup using a setup macro file

You can use a setup macro file to define breakpoints at C-SPY startup. Follow the procedure described in *Using C-SPY macros*, page 307.

## USEFUL BREAKPOINT HINTS

Below are some useful hints related to setting breakpoints.



### Tracing incorrect function arguments

If a function with a pointer argument is sometimes incorrectly called with a `NULL` argument, you might want to debug that behavior. These methods can be useful:

- Set a breakpoint on the first line of the function with a condition that is true only when the parameter is 0. The breakpoint will then not be triggered until the problematic situation actually occurs. The advantage of this method is that no extra source code is needed. The drawback is that the execution speed might become unacceptably low.



- You can use the `assert` macro in your problematic function, for example:

```
int MyFunction(int * MyPtr)
{
    assert(MyPtr != 0); /* Assert macro added to your source
                        code. */
    /* Here comes the rest of your function. */
}
```

The execution will break whenever the condition is true. The advantage is that the execution speed is only very slightly affected, but the drawback is that you will get a small extra footprint in your source code. In addition, the only way to get rid of the execution stop is to remove the macro and rebuild your source code.

- Instead of using the `assert` macro, you can modify your function like this:

```
int MyFunction(int * MyPtr)
{
    if(MyPtr == 0)
        MyDummyStatement; /* Dummy statement where you set a
                           breakpoint. */
    /* Here comes the rest of your function. */
}
```

You must also set a breakpoint on the extra dummy statement, so that the execution will break whenever the condition is true. The advantage is that the execution speed is only very slightly affected, but the drawback is that you will still get a small extra footprint in your source code. However, in this way you can get rid of the execution stop by just removing the breakpoint.



### Performing a task and continuing execution

You can perform a task when a breakpoint is triggered and then automatically continue execution.

You can use the **Action** text box to associate an action with the breakpoint, for instance a C-SPY macro function. When the breakpoint is triggered and the execution of your application has stopped, the macro function will be executed. In this case, the execution will not continue automatically.

Instead, you can set a condition which returns 0 (false). When the breakpoint is triggered, the condition—which can be a call to a C-SPY macro that performs a task—is evaluated and because it is not true, execution continues.

Consider this example where the C-SPY macro function performs a simple task:

```
__var my_counter;

count ()
{
    my_counter += 1;
    return 0;
}
```

To use this function as a condition for the breakpoint, type `count ()` in the **Expression** text box under **Conditions**. The task will then be performed when the breakpoint is triggered. Because the macro function `count` returns 0, the condition is false and the execution of the program will resume automatically, without any stop.



### Using breakpoints when programming flash memory

When programming the flash memory, do not set a breakpoint on the instruction immediately following the *write to flash* operation. A simple work-around is to follow the *write to flash* operation with a `NOP` instruction, and set a breakpoint on the instruction following the `NOP` instruction.

---

## Reference information on breakpoints

Reference information about:

- *Breakpoints window*, page 115
- *Breakpoint Usage window*, page 117
- *Code breakpoints dialog box*, page 118
- *Log breakpoints dialog box*, page 119
- *Data breakpoints dialog box*, page 121
- *Data Log breakpoints dialog box*, page 123
- *Immediate breakpoints dialog box*, page 124
- *Range breakpoints dialog box*, page 125
- *Conditional breakpoints dialog box*, page 127
- *Advanced Trigger breakpoints dialog box*, page 130
- *Enter Location dialog box*, page 132
- *Breakpoint combiner dialog box*, page 133
- *Resolve Source Ambiguity dialog box*, page 134.

See also:

- *Reference information on C-SPY system macros*, page 319
- *Reference information on trace*, page 180.

## Breakpoints window

The **Breakpoints** window is available from the **View** menu.

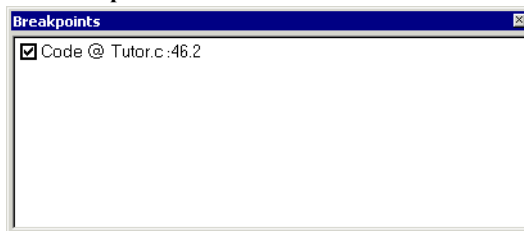

This window lists all breakpoints you define.

Use this window to conveniently monitor, enable, and disable breakpoints; you can also define new breakpoints and modify existing breakpoints.

### Requirements

None; this window is always available.

### Display area

This area lists all breakpoints you define. For each breakpoint, information about the breakpoint type, source file, source line, and source column is provided.

## Context menu

This context menu is available:

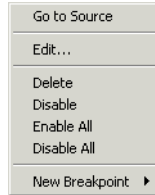

These commands are available:

### Go to Source

Moves the insertion point to the location of the breakpoint, if the breakpoint has a source location. Double-click a breakpoint in the **Breakpoints** window to perform the same command.

### Edit

Opens the breakpoint dialog box for the breakpoint you selected.

### Delete

Deletes the breakpoint. Press the Delete key to perform the same command.

### Enable

Enables the breakpoint. The check box at the beginning of the line will be selected. You can also perform the command by manually selecting the check box. This command is only available if the breakpoint is disabled.

### Disable

Disables the breakpoint. The check box at the beginning of the line will be deselected. You can also perform this command by manually deselecting the check box. This command is only available if the breakpoint is enabled.

### Enable All

Enables all defined breakpoints.

### Disable All

Disables all defined breakpoints.

### New Breakpoint

Displays a submenu where you can open the breakpoint dialog box for the available breakpoint types. All breakpoints you define using this dialog box are preserved between debug sessions.

## Breakpoint Usage window

The **Breakpoint Usage** window is available from the menu specific to the C-SPY driver you are using.

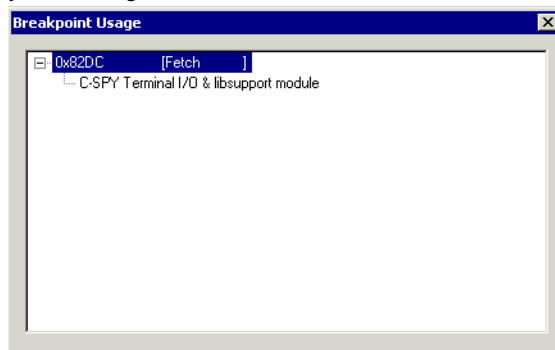

This window lists all breakpoints currently set in the target system, both the ones you have defined and the ones used internally by C-SPY. The format of the items in this window depends on the C-SPY driver you are using.

The window gives a low-level view of all breakpoints, related but not identical to the list of breakpoints displayed in the **Breakpoints** window.

C-SPY uses breakpoints when stepping. Use the **Breakpoint Usage** window for:

- Identifying all breakpoint consumers
- Checking that the number of active breakpoints is supported by the target system
- Configuring the debugger to use the available breakpoints in a better way, if possible.

For more information, see *Breakpoints in the C-SPY FET debugger driver*, page 106.

### Requirements

None; this window is always available.

### Display area

For each breakpoint in the list, the address and access type are displayed. Each breakpoint in the list can also be expanded to show its originator.

## Code breakpoints dialog box

The **Code** breakpoints dialog box is available from the context menu in the editor window, **Breakpoints** window, and in the **Disassembly** window.

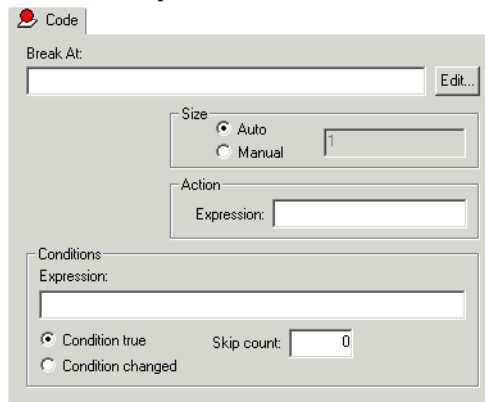

This figure reflects the C-SPY simulator.

Use the **Code** breakpoints dialog box to set a code breakpoint, see *Setting breakpoints using the dialog box*, page 109.

### Requirements

None; this dialog box is always available.

### Break At

Specify the code location of the breakpoint in the text box. Alternatively, click the **Edit** button to open the **Enter Location** dialog box, see *Enter Location dialog box*, page 132.

### Size

Determines whether there should be a size—in practice, a range—of locations where the breakpoint will trigger. Each fetch access to the specified memory range will trigger the breakpoint. Select how to specify the size:

#### Auto

The size will be set automatically, typically to 1.

#### Manual

Specify the size of the breakpoint range in the text box.

**Note:** The **Size** option is not available for the C-SPY FET Debugger driver.

**Action**

Specify a valid C-SPY expression, which is evaluated when the breakpoint is triggered and the condition is true. For more information, see *Useful breakpoint hints*, page 112.

**Conditions**

Specify simple or complex conditions:

**Expression**

Specify a valid C-SPY expression, see *C-SPY expressions*, page 80.

**Condition true**

The breakpoint is triggered if the value of the expression is true.

**Condition changed**

The breakpoint is triggered if the value of the expression has changed since it was last evaluated.

**Skip count**

The number of times that the breakpoint condition must be fulfilled before the breakpoint starts triggering. After that, the breakpoint will trigger every time the condition is fulfilled.

**Log breakpoints dialog box**

The **Log** breakpoints dialog box is available from the context menu in the editor window, **Breakpoints** window, and in the **Disassembly** window.

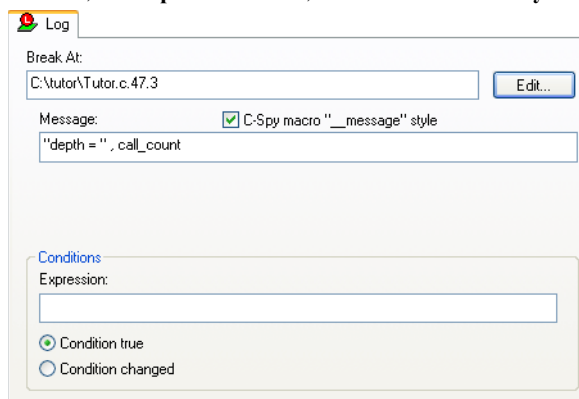

This figure reflects the C-SPY simulator.

Use the **Log** breakpoints dialog box to set a log breakpoint, see *Setting breakpoints using the dialog box*, page 109.

### Requirements

The C-SPY simulator.

### Trigger at

Specify the code location of the breakpoint. Alternatively, click the **Edit** button to open the **Enter Location** dialog box, see *Enter Location dialog box*, page 132.

### Message

Specify the message you want to be displayed in the C-SPY **Debug Log** window. The message can either be plain text, or—if you also select the option **C-SPY macro** "**\_\_message**" **style**—a comma-separated list of arguments.

### C-SPY macro "**\_\_message**" style

Select this option to make a comma-separated list of arguments specified in the **Message** text box be treated exactly as the arguments to the C-SPY macro language statement `__message`, see *Formatted output*, page 315.

### Conditions

Specify simple or complex conditions:

#### Expression

Specify a valid C-SPY expression, see *C-SPY expressions*, page 80.

#### Condition true

The breakpoint is triggered if the value of the expression is true.

#### Condition changed

The breakpoint is triggered if the value of the expression has changed since it was last evaluated.



## Data breakpoints dialog box

The **Data** breakpoints dialog box is available from the context menu in the editor window, **Breakpoints** window, the **Memory** window, and in the **Disassembly** window.

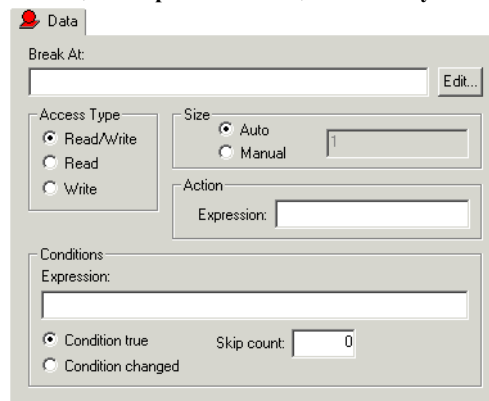

This figure reflects the C-SPY simulator.

Use the **Data** breakpoints dialog box to set a data breakpoint, see *Setting breakpoints using the dialog box*, page 109. Data breakpoints never stop execution within a single instruction. They are recorded and reported after the instruction is executed.

### Requirements

The C-SPY simulator.

### Break At

Specify the data location of the breakpoint in the text box. Alternatively, click the **Edit** button to open the **Enter Location** dialog box, see *Enter Location dialog box*, page 132.

### Access Type

Selects the type of memory access that triggers the breakpoint:

#### Read/Write

Reads from or writes to location.

#### Read

Reads from location.

#### Write

Writes to location.

## Size

Determines whether there should be a size—in practice, a range—of locations where the breakpoint will trigger. Each fetch access to the specified memory range will trigger the breakpoint. Select how to specify the size:

### Auto

The size will automatically be based on the type of expression the breakpoint is set on. For example, if you set the breakpoint on a 12-byte structure, the size of the breakpoint will be 12 bytes.

### Manual

Specify the size of the breakpoint range in the text box.

For data breakpoints, this can be useful if you want the breakpoint to be triggered on accesses to data structures, such as arrays, structs, and unions.

## Action

Specify a valid C-SPY expression, which is evaluated when the breakpoint is triggered and the condition is true. For more information, see *Useful breakpoint hints*, page 112.

## Conditions

Specify simple or complex conditions:

### Expression

Specify a valid C-SPY expression, see *C-SPY expressions*, page 80.

### Condition true

The breakpoint is triggered if the value of the expression is true.

### Condition changed

The breakpoint is triggered if the value of the expression has changed since it was last evaluated.

### Skip count

The number of times that the breakpoint condition must be fulfilled before the breakpoint starts triggering. After that, the breakpoint will trigger every time the condition is fulfilled.

## Data Log breakpoints dialog box

The **Data Log** breakpoints dialog box is available from the context menu in the **Breakpoints** window.

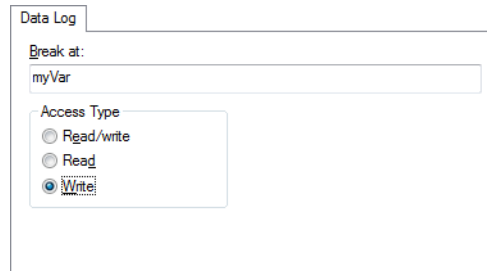

This figure reflects the C-SPY simulator.

Use the **Data Log** breakpoints dialog box to set a maximum of four data log breakpoints on memory addresses, see *Setting breakpoints using the dialog box*, page 109.

See also *Data Log breakpoints*, page 105 and *Getting started using data logging*, page 196.

### Requirements

The C-SPY simulator.

### Break At

Specify a memory location as a variable (with static storage duration) or as an address.

### Access Type

Selects the type of access to the variable that generates a log entry:

#### Read/Write

Read and write accesses from or writes to location of the variable.

#### Read

Read accesses from the location of the variable.

#### Write

Write accesses to location of the variable.

## Immediate breakpoints dialog box

The **Immediate** breakpoints dialog box is available from the context menu in the editor window, **Breakpoints** window, the **Memory** window, and in the **Disassembly** window.

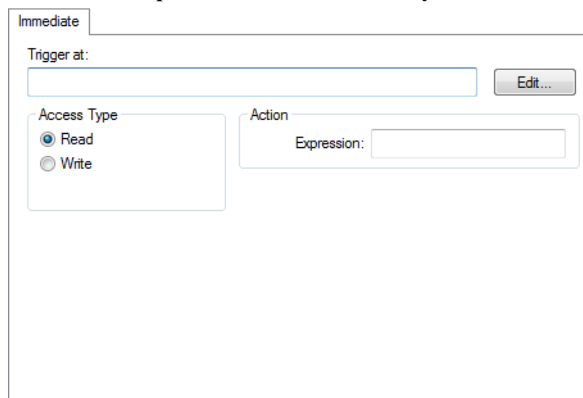

In the C-SPY simulator, use the **Immediate** breakpoints dialog box to set an immediate breakpoint, see *Setting breakpoints using the dialog box*, page 109. Immediate breakpoints do not stop execution at all; they only suspend it temporarily.

### Requirements

The C-SPY simulator.

### Trigger at

Specify the data location of the breakpoint. Alternatively, click the **Edit** button to open the **Enter Location** dialog box, see *Enter Location dialog box*, page 132.

### Access Type

Selects the type of memory access that triggers the breakpoint:

#### Read

Reads from location.

#### Write

Writes to location.

### Action

Specify a valid C-SPY expression, which is evaluated when the breakpoint is triggered and the condition is true. For more information, see *Useful breakpoint hints*, page 112.

## Range breakpoints dialog box

The **Range** breakpoints dialog box is available from the context menu in the Breakpoints window and the Memory window.

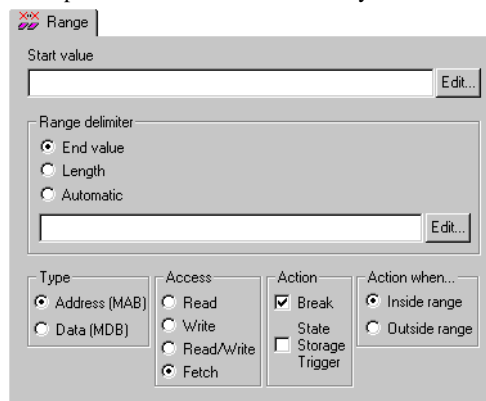

Use the **Range** breakpoints dialog box to set a range breakpoint.

Range breakpoints are available for the C-SPY FET Debugger driver on devices that support the Enhanced Emulation Module at the required level.

### Requirements

The C-SPY FET Debugger driver.

### Start value

Specify the start value for the range breakpoint in the **Start value** text box; an expression, an absolute address, or a source location. Alternatively, click the **Edit** button to open the **Enter Location** dialog box; see *Enter Location dialog box*, page 132.

### Range delimiter

Sets the end location of the range. Choose the type of delimiter and specify the value in the text box:

#### End value

The same type of value as for the **Start value**.

#### Length

The length of the range in bytes (in hexadecimal notation).

### **Automatic**

Bases the range automatically on the type of expression the breakpoint is set on. For example, if you set the breakpoint on a 12-byte structure, the range of the breakpoint will be 12 bytes.

## **Type**

Selects which breakpoint type to use:

### **Address (MAB)**

Sets a breakpoint on a specified address, or anything that can be evaluated to one. The breakpoint is triggered when the specified location is accessed. If you have set the breakpoint on a specific machine instruction, the breakpoint will be triggered and the execution will stop exactly before the instruction will be executed.

### **Data (MDB)**

Sets a breakpoint on a specified value. It is the value on the data bus that triggers the breakpoint.

## **Access type**

Selects the type of access that triggers the selected breakpoint:

### **Read**

Read from location.

### **Write**

Write to location.

### **Read/Write**

Read from or write to location.

### **Fetch**

At instruction fetch.

## **Action**

Selects the action that occurs when the breakpoint is triggered:

### **Break**

The execution stops when the breakpoint is triggered.

### **State Storage Trigger**

Defines the breakpoint as a state storage trigger. To control the behavior of the state storage module, see *State Storage Control window*, page 294.

**Action when**

Selects when the action shall occur:

**Inside range**

The action occurs at an access inside the specified range.

**Outside range**

The action occurs at an access outside of the specified range.

**Conditional breakpoints dialog box**

The **Conditional** breakpoints dialog box is available from the context menu in the Breakpoints window and the Disassembly window.

The screenshot shows the 'Conditional' dialog box with the following settings:

- Break At:** C:\EEM Examples\EEM\_examples\AdvancedDebugging1.c:70:3
- Type:** Address bus (MAB) (selected), Data bus (MDB), Register
- Operator:** == (selected), >=, <=, !=
- Access:** Read, Write, Read/Write, Fetch (selected)
- Mask:** 0xFFFFFFFF, Enable checkbox
- Condition:** MDB Value (empty), Mask: 0xFFFFFFFF, Enable checkbox
- Operator:** == (selected), >=, <=, !=
- Access:** Read, Write, Read/Write (selected)
- Action:** Break (checked), State Storage Trigger, Cycle Counter Trigger

Use the **Conditional** breakpoints dialog box to set a conditional breakpoint.

Conditional breakpoints are available for the C-SPY FET Debugger driver on devices that support the Enhanced Emulation Module at the required level.

**Requirements**

The C-SPY FET Debugger driver.

**Break At**

Specify the location for the breakpoint in the **Break At** text box. Alternatively, click the **Edit** button to open the **Enter Location** dialog box; see *Enter Location dialog box*, page 132.

## Type

Selects which breakpoint type to use:

### Address bus (MAB)

Sets a breakpoint on the address specified in the **Break At** text box, or anything that can be evaluated to one. The breakpoint is triggered when the specified location is accessed. If you have set the breakpoint on a specific machine instruction, the breakpoint will be triggered and the execution will stop exactly before the instruction will be executed.

### Data bus (MDB)

Sets a breakpoint on a specified value. It is the value on the data bus that triggers the breakpoint.

### Register

Sets a breakpoint on a register. Specify the register, or anything that can be evaluated to such, in the **Break At** text box. In the **Register Value** text box, type the value that should trigger the breakpoint.

## Operator

Selects a condition operator for when the breakpoint should be triggered:

==

Equal to.

>=

Greater than or equal to.

<=

Less than or equal to.

!=

Not equal to.

## Access

Selects the type of access that triggers the selected breakpoint:

### Read

Read from location.

### Write

Write to location.

### Read/Write

Read from or write to location.



**Fetch**

At instruction fetch.

**Mask**

Specify a bit mask value that the breakpoint address or value will be masked with. (On the FET hardware the mask is inverted, but this is *not* the case in the FET Debugger driver.)

**Condition**

Optionally, specify an additional condition to a conditional breakpoint. This means that a conditional breakpoint can be a single data breakpoint or a combination of two breakpoints that must occur at the same time. These settings can be specified for the additional condition:

**MDB/Register Value**

The extra conditional data value.

**Mask**

The bit mask value that the breakpoint value will be masked with.

**Operator**

The operator of condition, either ==, >=, <=, or !=.

**Access**

The access type of the condition, either Read, Write, or Read/Write.

**Action**

Selects the action that occurs when the breakpoint is triggered:

**Break**

The execution stops when the breakpoint is triggered.

**State Storage Trigger**

State storage starts when the breakpoint is triggered. To control the behavior of the state storage module, see *State Storage Control window*, page 294.

**Cycle Counter Trigger**

Starts, stops, resets, or counts the Cycle counter 1. To control the behavior of the cycle counter, see *The advanced cycle counter*, page 283.

## Advanced Trigger breakpoints dialog box

The **Advanced Trigger** breakpoints dialog box is available from the context menu in the Breakpoints window and the Disassembly window.

Use the **Advanced Trigger** breakpoints dialog box to set an advanced trigger breakpoint.

Advanced trigger breakpoints are available for the C-SPY FET Debugger driver on devices that support the Enhanced Emulation Module at the required level.

### Requirements

The C-SPY FET Debugger driver.

### Break At

Specify the location for the breakpoint in the **Break At** text box. Alternatively, click the **Edit** button to open the **Enter Location** dialog box; see *Enter Location dialog box*, page 132.

### Type

Selects which breakpoint type to use:

#### Address bus (MAB)

Sets a breakpoint on a specified address, or anything that can be evaluated to one. The breakpoint is triggered when the specified location is accessed. If you have set the breakpoint on a specific machine instruction, the breakpoint will be triggered and the execution will stop exactly before the instruction will be executed.

**Data bus (MDB)**

Sets a breakpoint on a specified value. It is the value on the data bus that triggers the breakpoint.

**Register**

Sets a breakpoint on a register. Specify the register, or anything that can be evaluated to such, in the **Break At** text box. In the **Value** text box, type the value that should trigger the breakpoint.

**Operator**

Selects a condition operator for when the breakpoint should be triggered:

==

Equal to.

>=

Greater than or equal to.

<=

Less than or equal to.

!=

Not equal to.

**Mask**

Specify a bit mask value that the breakpoint address or value will be masked with. (On the FET hardware the mask is inverted, but this is *not* the case in the FET Debugger driver.)

**Value**

Specify the data value in the specified register that should be triggered.

**Access type**

Selects the type of access that triggers the selected breakpoint.

**Action**

Selects the action that occurs when the breakpoint is triggered:

**Break**

The execution stops when the breakpoint is triggered.

### State Storage Trigger

State storage starts when the breakpoint is triggered. To control the behavior of the state storage module, see *State Storage Control window*, page 294.

### Cycle Counter Trigger

Starts, stops, resets, or counts the Cycle counter 1. To control the behavior of the cycle counter, see *The advanced cycle counter*, page 283.

## Enter Location dialog box

The **Enter Location** dialog box is available from the breakpoints dialog box, either when you set a new breakpoint or when you edit a breakpoint.

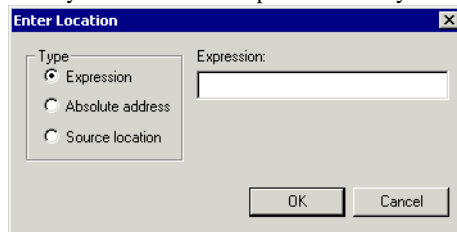

Use the **Enter Location** dialog box to specify the location of the breakpoint.

**Note:** This dialog box looks different depending on the **Type** you select.

### Type

Selects the type of location to be used for the breakpoint, choose between:

#### Expression

A C-SPY expression, whose value evaluates to a valid code or data location.

A code location, for example the function `main`, is typically used for code breakpoints.

A data location is the name of a variable and is typically used for data breakpoints. For example, `my_var` refers to the location of the variable `my_var`, and `arr[3]` refers to the location of the fourth element of the array `arr`. For static variables declared with the same name in several functions, use the syntax `my_func::my_static_variable` to refer to a specific variable.

For more information about C-SPY expressions, see *C-SPY expressions*, page 80.

### Absolute address

An absolute location on the form *zone:hexaddress* or simply *hexaddress* (for example `Memory:0x42`). *zone* refers to C-SPY memory zones and specifies in which memory the address belongs, see *C-SPY memory zones*, page 138.

### Source location

A location in your C source code using the syntax:

```
{filename}.row.column.
```

*filename* specifies the filename and full path.

*row* specifies the row in which you want the breakpoint.

*column* specifies the column in which you want the breakpoint.

For example, `{C:\src\prog.c}.22.3`

sets a breakpoint on the third character position on row 22 in the source file `prog.c`. Note that in quoted form, for example in a C-SPY macro, you must instead write `{C:\src\prog.c}.22.3`.

Note that the Source location type is usually meaningful only for code locations in code breakpoints. Depending on the C-SPY driver you are using, **Source location** might not be available for data and immediate breakpoints.

## Breakpoint combiner dialog box

The **Breakpoint combiner** dialog box is available from the **Emulator** menu.

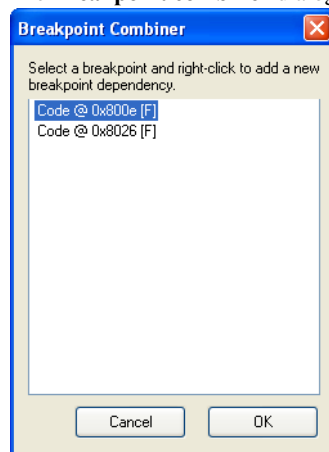

Use this dialog box to combine two already defined breakpoints.

Select a breakpoint and right-click to display a list of breakpoints to combine it with. When two breakpoints have been combined, the defined action will not occur until both breakpoints have been reached.

**Note:** Only available for devices that support the Enhanced Emulation Module at the required level. The settings are not saved when the debug session is closed.

## Requirements

The C-SPY FET Debugger driver.

## Resolve Source Ambiguity dialog box

The **Resolve Source Ambiguity** dialog box appears, for example, when you try to set a breakpoint on templates and the source location corresponds to more than one function.

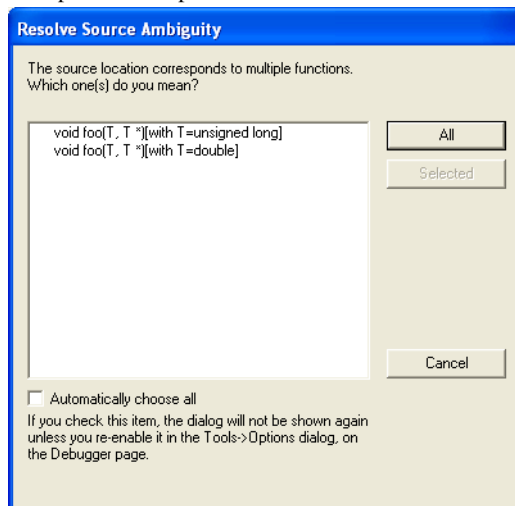

To resolve a source ambiguity, perform one of these actions:

- In the text box, select one or several of the listed locations and click **Selected**.
- Click **All**.

### All

The breakpoint will be set on all listed locations.

### Selected

The breakpoint will be set on the source locations that you have selected in the text box.

**Cancel**

No location will be used.

**Automatically choose all**

Determines that whenever a specified source location corresponds to more than one function, all locations will be used.

Note that this option can also be specified in the **IDE Options** dialog box, see Debugger options in the *IDE Project Management and Building Guide*.





# Memory and registers

- Introduction to monitoring memory and registers
- Monitoring memory and registers
- Reference information on memory and registers

---

## Introduction to monitoring memory and registers

These topics are covered:

- Briefly about monitoring memory and registers
- C-SPY memory zones
- Memory configuration for the C-SPY simulator

### BRIEFLY ABOUT MONITORING MEMORY AND REGISTERS

C-SPY provides many windows for monitoring memory and registers, each of them available from the **View** menu:

- The **Memory** window  
Gives an up-to-date display of a specified area of memory—a memory zone—and allows you to edit it. *Data coverage* along with execution of your application is highlighted with different colors. You can fill specified areas with specific values and you can set breakpoints directly on a memory location or range. You can open several instances of this window, to monitor different memory areas. The content of the window can be regularly updated while your application is executing.
- The **Symbolic Memory** window  
Displays how variables with static storage duration are laid out in memory. This can be useful for better understanding memory usage or for investigating problems caused by variables being overwritten, for example by buffer overruns.
- The **Stack** window  
Displays the contents of the stack, including how stack variables are laid out in memory. In addition, integrity checks of the stack can be performed to detect and warn about problems with stack overflow. For example, the **Stack** window is useful for determining the optimal size of the stack. You can open up to two instances of this window, each showing different stacks or different display modes of the same stack.

- The **Registers** window

Gives an up-to-date display of the contents of the processor registers and SFRs, and allows you to edit them. Because of the large amount of registers—memory-mapped peripheral unit registers and CPU registers—it is inconvenient to show all registers concurrently in the **Registers** window. Instead you can divide registers into *application-specific groups*. You can choose to load either predefined register groups or define your own groups. You can open several instances of this window, each showing a different register group.

- The **SFR Setup** window

Displays the currently defined SFRs that C-SPY has information about, both factory-defined (retrieved from the device description file) and custom-defined SFRs. If required, you can use the **Edit SFR** dialog box to customize the SFR definitions.

To view the memory contents for a specific variable, simply drag the variable to the **Memory** window or the **Symbolic** memory window. The memory area where the variable is located will appear.



Reading the value of some registers might influence the runtime behavior of your application. For example, reading the value of a UART status register might reset a pending bit, which leads to the lack of an interrupt that would have processed a received byte. To prevent this from happening, make sure that the **Registers** window containing any such registers is closed when debugging a running application.

## C-SPY MEMORY ZONES

In C-SPY, the term *zone* is used for a named memory area. A memory address, or *location*, is a combination of a zone and a numerical offset into that zone. The MSP430

architecture has only one zone, `Memory`, which covers the whole MSP430 memory range.

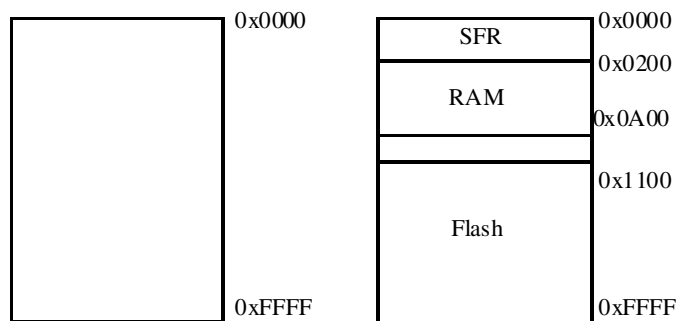

Default zone `Memory`

Additional zones for MSP430F149

Memory zones are used in several contexts, most importantly in the **Memory** and **Disassembly** windows, and in C-SPY macros. In the windows, use the **Zone** box to choose which memory zone to display.

### Device-specific zones

Memory information for device-specific zones is defined in the *device description files*. When you load a device description file, additional zones that adhere to the specific memory layout become available.

See the device description file for information about available memory zones.

These zones are available, depending on the device description file you are using: `SFR`, `RAM`, `INFO`, and `Flash`. Some devices have `FRAM` instead of `Flash`.

If your hardware does not have the same memory layout as any of the predefined device description files, you can define customized zones by adding them to the file.

For more information, see *Selecting a device description file*, page 44 and *Modifying a device description file*, page 48.

## MEMORY CONFIGURATION FOR THE C-SPY SIMULATOR

To simulate the target system properly, the C-SPY simulator needs information about the memory configuration. By default, C-SPY uses a configuration based on information retrieved from the device description file.

The C-SPY simulator provides various mechanisms to improve the configuration further:

- If the default memory configuration does not specify the required memory address ranges, you can specify the memory address ranges shall be based on:
  - The zones predefined in the device description file
  - The section information available in the debug file
  - Or, you can define your own memory address ranges, which you typically might want to do if the files do not specify memory ranges for the *specific* device that you are using, but instead for a *family* of devices (perhaps with various amounts of on-chip RAM).
- For each memory address range, you can specify an *access type*. If a memory access occurs that does not agree with the specified access type, C-SPY will regard this as an illegal access and warn about it. In addition, an access to memory that is not defined is regarded as an illegal access. The purpose of memory access checking is to help you to identify memory access violations.

For more information, see *Memory Access Setup dialog box*, page 169.

---

## Monitoring memory and registers

These tasks are covered:

- *Defining application-specific register groups*, page 141
- *Monitoring stack usage*, page 142

## DEFINING APPLICATION-SPECIFIC REGISTER GROUPS

Defining application-specific register groups minimizes the amount of registers displayed in the **Registers** windows and makes the debugging easier.

- 1 Choose **View>Registers>Register User Groups Setup** during a debug session.

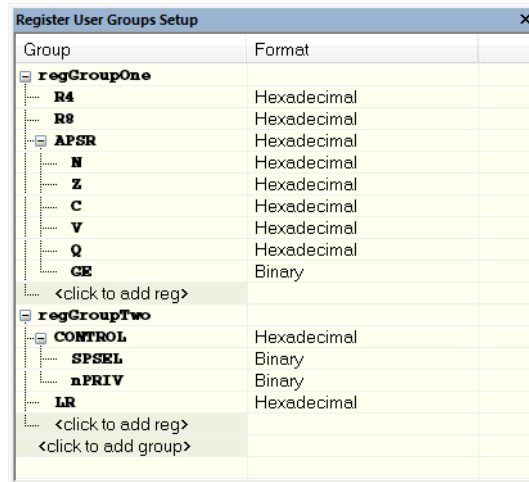

Right-clicking in the window displays a context menu with commands. For information about these commands, see *Register User Groups Setup window*, page 162.

- 2 Click on <click to add group> and specify the name of your group, for example **My Timer Group** and press Enter.
- 3 Underneath the group name, click on <click to add reg> and type the name of a register, and press Enter. You can also drag a register name from another window in the IDE. Repeat this for all registers that you want to add to your group.
- 4 As an optional step, right-click any registers for which you want to change the integer base, and choose **Format** from the context menu to select a suitable base.
- 5 When you are done, your new group is now available in the **Registers** windows.

If you want to define more application-specific groups, repeat this procedure for each group you want to define.

**Note:** If a certain SFR that you need cannot be added to a group, you can register your own SFRs. For more information, see *SFR Setup window*, page 164.

## MONITORING STACK USAGE

These are the two main use cases for the **Stack** window:

- Monitoring stack memory usage
- Monitoring the stack memory content.

In both cases, C-SPY retrieves information about the defined stack size and its allocation from the definition in the linker configuration file of the segment holding the stack. If you, for some reason, have modified the stack initialization in the system startup code, `cstartup`, you should also change the segment definition in the linker configuration file accordingly; otherwise the **Stack** window cannot track the stack usage. For more information about this, see the *IAR C/C++ Compiler User Guide for MSP430*.

### To monitor stack memory usage:

1 Before you start C-SPY, choose **Tools>Options**. On the **Stack** page:

- Select **Enable graphical stack display and stack usage tracking**. This option also enables the option **Warn when exceeding stack threshold**. Specify a suitable threshold value.
- Notice also the option **Warn when stack pointer is out of bounds**. Any such warnings are displayed in the **Debug Log** window.

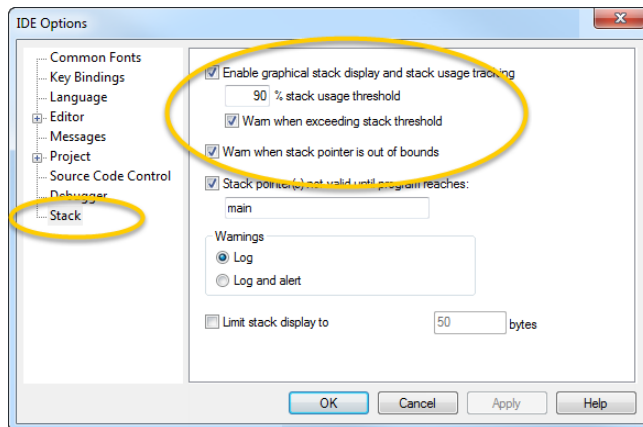

2 Start C-SPY.

When your application is first loaded, and upon each reset, the memory for the stack area is filled with the dedicated byte value `0xCD` before the application starts executing.

3 Choose **View>Stack>Stack 1** to open the **Stack** window.

Notice that you can open up to two **Stack** windows, each showing a different stack—if several stacks are available—or the same stack with different display settings.

#### 4 Start executing your application.

Whenever execution stops, the stack memory is searched from the end of the stack until a byte whose value is not `0xCD` is found, which is assumed to be how far the stack has been used. The light gray area of the stack bar represents the *unused* stack memory area, whereas the dark gray area of the bar represents the *used* stack memory.

For this example, you can see that only 44% of the reserved memory address range was used, which means that it could be worth considering decreasing the size of memory:

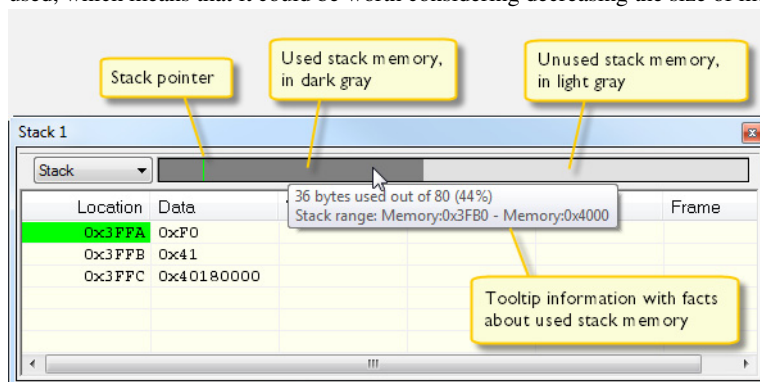

**Note:** Although this is a reasonably reliable way to track stack usage, there is no guarantee that a stack overflow is detected. For example, a stack *can* incorrectly grow outside its bounds, and even modify memory outside the stack area, without actually modifying any of the bytes near the end of the stack range. Likewise, your application might modify memory within the stack area by mistake.

See also the *IAR C/C++ Compiler User Guide for MSP430* for information about stack usage analysis.

#### To monitor the stack memory content:

- 1 Before you start monitoring stack memory, you might want to disable the option **Enable graphical stack display and stack usage tracking** to improve performance during debugging.
- 2 Start C-SPY.
- 3 Choose **View>Stack>Stack 1** to open the **Stack** window.

Notice that you can access various context menus in the display area from where you can change display format, etc.

#### 4 Start executing your application.

Whenever execution stops, you can monitor the stack memory, for example to see function parameters that are passed on the stack:

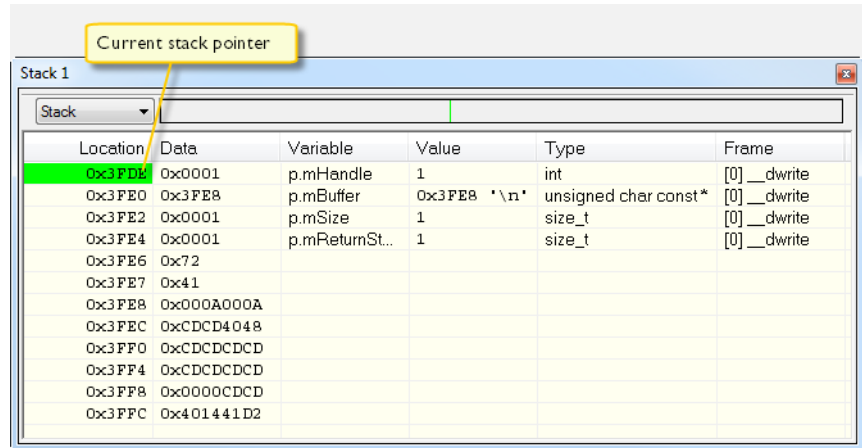

## Reference information on memory and registers

Reference information about:

- *Memory window*, page 145
- *Memory Save dialog box*, page 149
- *Memory Restore dialog box*, page 150
- *Fill dialog box*, page 151
- *Symbolic Memory window*, page 152
- *Stack window*, page 155
- *Registers window*, page 159
- *Register User Groups Setup window*, page 162
- *SFR Setup window*, page 164
- *Edit SFR dialog box*, page 167
- *Memory Access Setup dialog box*, page 169
- *Edit Memory Access dialog box*, page 171.
- *Memory Dump dialog box*, page 172



## Memory window

The **Memory** window is available from the **View** menu.

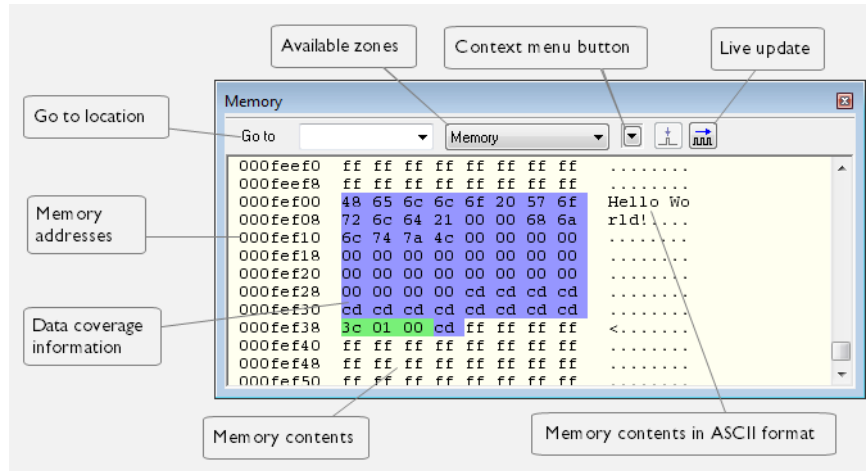

This window gives an up-to-date display of a specified area of memory—a memory zone—and allows you to edit it. You can open several instances of this window, which is very convenient if you want to keep track of several memory or register zones, or monitor different parts of the memory.



To view the memory corresponding to a variable, you can select it in the editor window and drag it to the **Memory** window.

See also *Editing in C-SPY windows*, page 47.

### Requirements

None; this window is always available.

### Toolbar

The toolbar contains:

#### Go to

The memory location or symbol you want to view.

#### Zone

Selects a memory zone, see *C-SPY memory zones*, page 138.

#### Context menu button

Displays the context menu.

### Update Now

Updates the content of the **Memory** window while your application is executing. This button is only enabled if the C-SPY driver you are using has access to the target system memory while your application is executing.

### Live Update

Updates the contents of the **Memory** window regularly while your application is executing. This button is only enabled if the C-SPY driver you are using has access to the target system memory while your application is executing. To set the update frequency, specify an appropriate frequency in the **IDE Options>Debugger** dialog box.

### Display area

The display area shows the addresses currently being viewed, the memory contents in the format you have chosen, and—provided that the display mode is set to **1x Units**—the memory contents in ASCII format. You can edit the contents of the display area, both in the hexadecimal part and the ASCII part of the area.

Data coverage is displayed with these colors:

Yellow	Indicates data that has been read.
Blue	Indicates data that has been written
Green	Indicates data that has been both read and written.

**Note:** Data coverage is not supported by all C-SPY drivers. Data coverage is supported by the C-SPY Simulator.

## Context menu

This context menu is available:

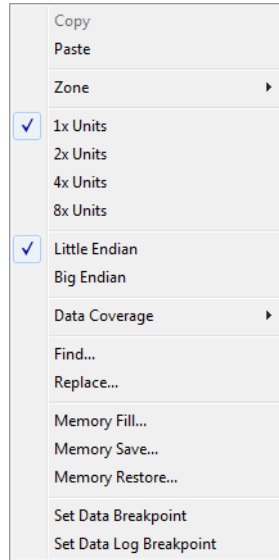

These commands are available:

### Copy, Paste

Standard editing commands.

### Zone

Selects a memory zone, see *C-SPY memory zones*, page 138.

### 1x Units

Displays the memory contents as single bytes.

### 2x Units

Displays the memory contents as 2-byte groups.

### 4x Units

Displays the memory contents as 4-byte groups.

### 8x Units

Displays the memory contents as 8-byte groups.

### Little Endian

Displays the contents in little-endian byte order.

### **Big Endian**

Displays the contents in big-endian byte order.

### **Data Coverage**

Choose between:

**Enable** toggles data coverage on or off.

**Show** toggles between showing or hiding data coverage.

**Clear** clears all data coverage information.

These commands are only available if your C-SPY driver supports data coverage.

### **Find**

Displays a dialog box where you can search for text within the **Memory** window; read about the **Find** dialog box in the *IDE Project Management and Building Guide*.

### **Replace**

Displays a dialog box where you can search for a specified string and replace each occurrence with another string; read about the **Replace** dialog box in the *IDE Project Management and Building Guide*.

### **Memory Fill**

Displays a dialog box, where you can fill a specified area with a value, see *Fill dialog box*, page 151.

### **Memory Save**

Displays a dialog box, where you can save the contents of a specified memory area to a file, see *Memory Save dialog box*, page 149.

### **Memory Restore**

Displays a dialog box, where you can load the contents of a file in Intel-hex or Motorola s-record format to a specified memory zone, see *Memory Restore dialog box*, page 150.

### **Set Data Breakpoint**

Sets breakpoints directly in the **Memory** window. The breakpoint is not highlighted; you can see, edit, and remove it in the **Breakpoints** dialog box. The breakpoints you set in this window will be triggered for both read and write access. For more information, see *Setting a data breakpoint in the Memory window*, page 111.

### Set Data Log Breakpoint

Sets a breakpoint on the start address of a memory selection directly in the **Memory** window. The breakpoint is not highlighted; you can see, edit, and remove it in the **Breakpoints** dialog box. The breakpoints you set in this window will be triggered by both read and write accesses; to change this, use the **Breakpoints** window. For more information, see *Data Log breakpoints*, page 105 and *Getting started using data logging*, page 196.

## Memory Save dialog box

The **Memory Save** dialog box is available by choosing **Debug>Memory>Save** or from the context menu in the **Memory** window.

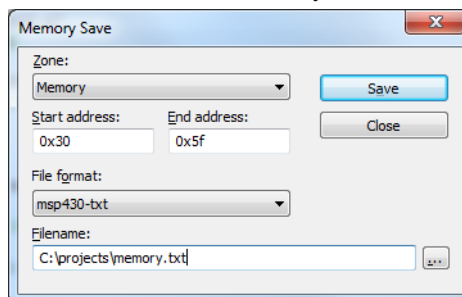

Use this dialog box to save the contents of a specified memory area to a file.

### Requirements

None; this dialog box is always available.

### Zone

Selects a memory zone, see *C-SPY memory zones*, page 138.

### Start address

Specify the start address of the memory range to be saved.

### End address

Specify the end address of the memory range to be saved.

### File format

Selects the file format to be used, which is msp430-txt by default.

**Filename**

Specify the destination file to be used; a browse button is available for your convenience.

**Save**

Saves the selected range of the memory zone to the specified file.

## Memory Restore dialog box

The **Memory Restore** dialog box is available by choosing **Debug>Memory>Restore** or from the context menu in the **Memory** window.

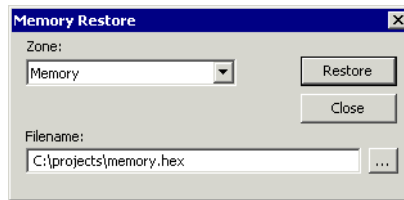

Use this dialog box to load the contents of a file in Intel-extended, Motorola S-record, or TI msp430-txt format to a specified memory zone.

**Requirements**

None; this dialog box is always available.

**Zone**

Selects a memory zone, see *C-SPY memory zones*, page 138.

**Filename**

Specify the file to be read; a browse button is available for your convenience.

**Restore**

Loads the contents of the specified file to the selected memory zone.

## Fill dialog box

The **Fill** dialog box is available from the context menu in the **Memory** window.

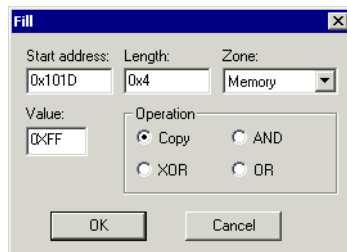

Use this dialog box to fill a specified area of memory with a value.

### Requirements

None; this dialog box is always available.

### Start address

Type the start address—in binary, octal, decimal, or hexadecimal notation.

### Length

Type the length—in binary, octal, decimal, or hexadecimal notation.

### Zone

Selects a memory zone, see *C-SPY memory zones*, page 138.

### Value

Type the 8-bit value to be used for filling each memory location.

### Operation

These are the available memory fill operations:

#### Copy

Value will be copied to the specified memory area.

#### AND

An AND operation will be performed between Value and the existing contents of memory before writing the result to memory.

#### XOR

An XOR operation will be performed between Value and the existing contents of memory before writing the result to memory.

OR

An OR operation will be performed between Value and the existing contents of memory before writing the result to memory.

## Symbolic Memory window

The **Symbolic Memory** window is available from the **View** menu during a debug session.

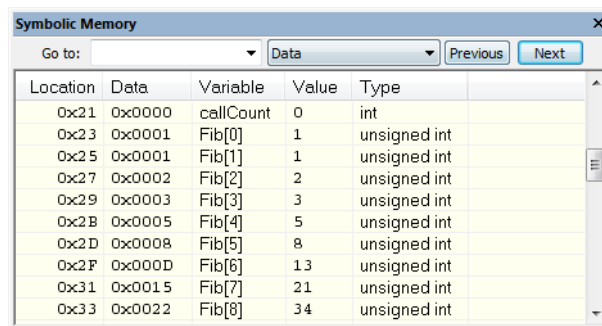

Location	Data	Variable	Value	Type
0x21	0x0000	callCount	0	int
0x23	0x0001	Fib[0]	1	unsigned int
0x25	0x0001	Fib[1]	1	unsigned int
0x27	0x0002	Fib[2]	2	unsigned int
0x29	0x0003	Fib[3]	3	unsigned int
0x2B	0x0005	Fib[4]	5	unsigned int
0x2D	0x0008	Fib[5]	8	unsigned int
0x2F	0x000D	Fib[6]	13	unsigned int
0x31	0x0015	Fib[7]	21	unsigned int
0x33	0x0022	Fib[8]	34	unsigned int

This window displays how variables with static storage duration, typically variables with file scope but also static variables in functions and classes, are laid out in memory. This can be useful for better understanding memory usage or for investigating problems caused by variables being overwritten, for example buffer overruns. Other areas of use are spotting alignment holes or for understanding problems caused by buffers being overwritten.



To view the memory corresponding to a variable, you can select it in the editor window and drag it to the **Symbolic Memory** window.

See also *Editing in C-SPY windows*, page 47.

### Requirements

None; this window is always available.

### Toolbar

The toolbar contains:

#### Go to

The memory location or symbol you want to view.

#### Zone

Selects a memory zone, see *C-SPY memory zones*, page 138.



**Previous**

Highlights the previous symbol in the display area.

**Next**

Highlights the next symbol in the display area.

**Display area**

This area contains these columns:

**Location**

The memory address.

**Data**

The memory contents in hexadecimal format. The data is grouped according to the size of the symbol. This column is editable.

**Variable**

The variable name; requires that the variable has a fixed memory location. Local variables are not displayed.

**Value**

The value of the variable. This column is editable.

**Type**

The type of the variable.

There are several different ways to navigate within the memory space:

- Text that is dropped in the window is interpreted as symbols
- The scroll bar at the right-side of the window
- The toolbar buttons **Next** and **Previous**
- The toolbar list box **Go to** can be used for locating specific locations or symbols.

**Note:** Rows are marked in red when the corresponding value has changed.

## Context menu

This context menu is available:

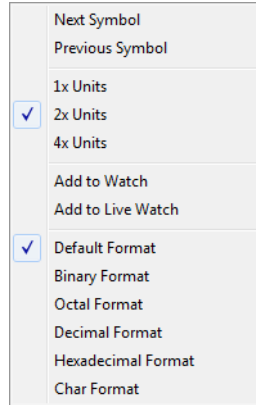

These commands are available:

### Next Symbol

Highlights the next symbol in the display area.

### Previous Symbol

Highlights the previous symbol in the display area.

### 1x Units

Displays the memory contents as single bytes. This applies only to rows which do not contain a variable.

### 2x Units

Displays the memory contents as 2-byte groups.

### 4x Units

Displays the memory contents as 4-byte groups.

### Add to Watch

Adds the selected symbol to the **Watch** window.

### Add to Live Watch

Adds the selected symbol to the **Live Watch** window.

### Default format

Displays the memory contents in the default format.

### Binary format

Displays the memory contents in binary format.

**Octal format**

Displays the memory contents in octal format.

**Decimal format**

Displays the memory contents in decimal format.

**Hexadecimal format**

Displays the memory contents in hexadecimal format.

**Char format**

Displays the memory contents in char format.

**Stack window**

The **Stack** window is available from the **View** menu.

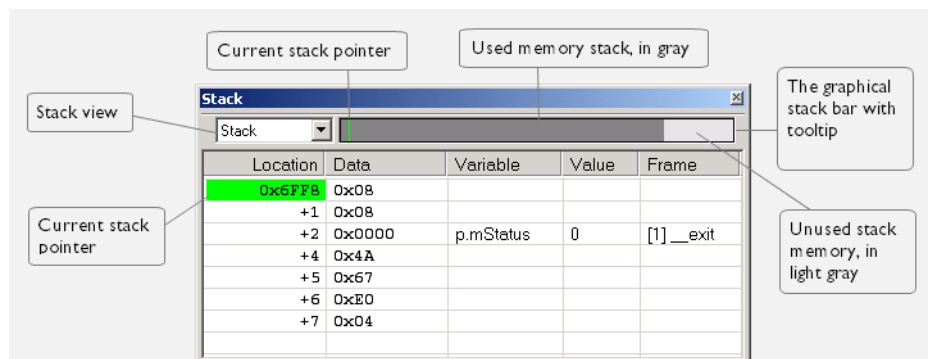

This window is a memory window that displays the contents of the stack. The graphical stack bar shows stack usage.

**Note:** By default, this window uses one physical breakpoint. For more information, see *Breakpoint consumers*, page 107.

For information about options specific to the **Stack** window, see the *IDE Project Management and Building Guide*.

**Requirements**

None; this window is always available.

## Toolbar

The toolbar contains:

### Stack

Selects which stack to view. This applies to microcontrollers with multiple stacks.

## The graphical stack bar

Displays the state of the stack graphically.

The left end of the stack bar represents the bottom of the stack, in other words, the position of the stack pointer when the stack is empty. The right end represents the end of the memory address range reserved for the stack. The graphical stack bar turns red when the stack usage exceeds a threshold that you can specify.

To enable the stack bar, choose **Tools>Options>Stack>Enable graphical stack display and stack usage tracking**. This means that the functionality needed to detect and warn about stack overflows is enabled.



Place the mouse pointer over the stack bar to get tooltip information about stack usage.

## Display area

This area contains these columns:

### Location

Displays the location in memory. The addresses are displayed in increasing order. The address referenced by the stack pointer, in other words the top of the stack, is highlighted in a green color.

### Data

Displays the contents of the memory unit at the given location. From the **Stack** window context menu, you can select how the data should be displayed; as a 1-, 2-, or 4-byte group of data.

### Variable

Displays the name of a variable, if there is a local variable at the given location. Variables are only displayed if they are declared locally in a function, and located on the stack and not in registers.

### Value

Displays the value of the variable.

### Type

Displays the data type of the variable.

**Frame**

Displays the name of the function that the call frame corresponds to.

**Context menu**

This context menu is available:

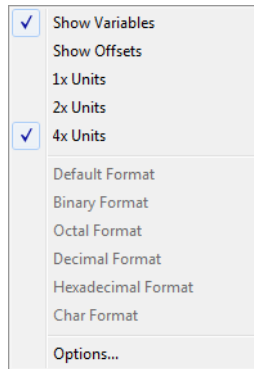

These commands are available:

**Show variables**

Displays separate columns named **Variables**, **Value**, and **Frame** in the **Stack** window. Variables located at memory addresses listed in the **Stack** window are displayed in these columns.

**Show offsets**

Displays locations in the **Location** column as offsets from the stack pointer. When deselected, locations are displayed as absolute addresses.

**1x Units**

Displays the memory contents as single bytes.

**2x Units**

Displays the memory contents as 2-byte groups.

**4x Units**

Displays the memory contents as 4-byte groups.

**Default Format,  
Binary Format,  
Octal Format,  
Decimal Format,  
Hexadecimal Format,  
Char Format**

Changes the display format of expressions. The display format setting affects different types of expressions in different ways. Your selection of display format is saved between debug sessions. These commands are available if a selected line in the window contains a variable.

The display format setting affects different types of expressions in these ways:

Variables	The display setting affects only the selected variable, not other variables.
Array elements	The display setting affects the complete array, that is, the same display format is used for each array element.
Structure fields	All elements with the same definition—the same field name and C declaration type—are affected by the display setting.

**Options**

Opens the **IDE Options** dialog box where you can set options specific to the **Stack** window, see the *IDE Project Management and Building Guide*.

## Registers window

The **Registers** windows are available from the **View** menu.

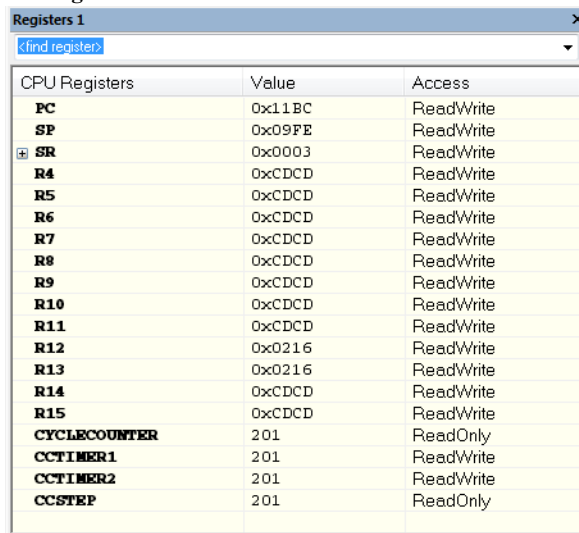

CPU Registers	Value	Access
<b>PC</b>	0x11BC	ReadWrite
<b>SP</b>	0x09FE	ReadWrite
<b>SR</b>	0x0003	ReadWrite
<b>R4</b>	0xCDCD	ReadWrite
<b>R5</b>	0xCDCD	ReadWrite
<b>R6</b>	0xCDCD	ReadWrite
<b>R7</b>	0xCDCD	ReadWrite
<b>R8</b>	0xCDCD	ReadWrite
<b>R9</b>	0xCDCD	ReadWrite
<b>R10</b>	0xCDCD	ReadWrite
<b>R11</b>	0xCDCD	ReadWrite
<b>R12</b>	0x0216	ReadWrite
<b>R13</b>	0x0216	ReadWrite
<b>R14</b>	0xCDCD	ReadWrite
<b>R15</b>	0xCDCD	ReadWrite
<b>CYCLECOUNTER</b>	201	ReadOnly
<b>CCTIMER1</b>	201	ReadWrite
<b>CCTIMER2</b>	201	ReadWrite
<b>CCSTEP</b>	201	ReadOnly

These windows give an up-to-date display of the contents of the processor registers and special function registers, and allows you to edit the content of some of the registers. Optionally, you can choose to load either predefined register groups or your own user-defined groups.

You can open up to four instances of this window, which is very convenient if you want to keep track of different register groups.

See also *Editing in C-SPY windows*, page 47.

### To enable predefined register groups:

- 1 Select a device description file that suits your device, see *Selecting a device description file*, page 44.
- 2 Display the register groups that are defined in the device description file in the **Registers** window by right-clicking in the window and choosing **View Group** from the context menu.

For information about creating your own user-defined register groups, see *Defining application-specific register groups*, page 141.

### Requirements

None; this window is always available.

## Toolbar

The toolbar contains:

### <find register>

Specify the name of a register that you want to find. Press the Enter key and the first register group where this register is found is displayed. User-defined register groups are not searched. The register search box has a history depth of 20 search entries.

## Display area

Displays registers and their values. Some registers are expandable, which means that the register contains interesting bits or subgroups of bits.

If you drag a numerical value, a valid expression, or a register name from another part of the IDE to an editable value cell in a **Registers** window, the value will be changed to that of what you dragged. If you drop a register name somewhere else in the window, the window contents will change to display the first register group where this register is found.

### *Register group name*

The name of the register.

### **Value**

The current value of the register. Every time C-SPY stops, a value that has changed since the last stop is highlighted. Some of the registers are editable. To edit the contents of an editable register, click it and modify its value. Press Esc to cancel the change.

To change the display format of the value, right-click on the register and choose **Format** from the context menu.

### **Access**

The access type of the register. Some of the registers are read-only, some of the registers are write-only.

**Note:** When the FET Debugger is used, the cycle counter registers can only be used while single-stepping in the **Disassembly** window.



For the C-SPY Simulator (and some C-SPY hardware debugger drivers), these additional support registers are available in the `group`:

<b>CYCLECOUNTER</b>	Cleared when an application is started or reset and is incremented with the number of used cycles during execution.
<b>CCSTEP</b>	Shows the number of used cycles during the last performed C/C++ source or assembler step.
<b>CCTIMER1</b> and <b>CCTIMER2</b>	Two <i>trip counts</i> that can be cleared manually at any given time. They are incremented with the number of used cycles during execution.

### Context menu

This context menu is available:

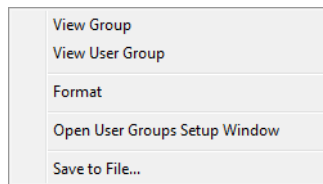

These commands are available:

#### View Group

Selects which predefined register group to display, by default **CPU Registers**. If some of your SFRs are missing, you can register your own SFRs in a Custom group, see *SFR Setup window*, page 164. Additional predefined registers are defined in a specific register definition file—with the filename extension `sfr`—which is included from the register section of the device description file. These registers are the device-specific memory-mapped control and status registers for the peripheral units on the MSP430 microcontrollers.

#### View User Group

Selects which user-defined register group to display. For information about creating your own user-defined register groups, see *Defining application-specific register groups*, page 141.

#### Format

Changes the display format for the contents of the register you clicked on. The display format setting affects different types of registers in different ways. Your selection of display format is saved between debug sessions.

**Open User Groups Setup Window**

Opens a window where you can create your own user-defined register groups, see *Register User Groups Setup window*, page 162.

**Save to File**

Opens a standard save dialog box to save the contents of the window to a tab-separated text file.

**Register User Groups Setup window**

The **Register User Groups Setup** window is available from the **View** menu or from the context menu in the **Registers** windows.

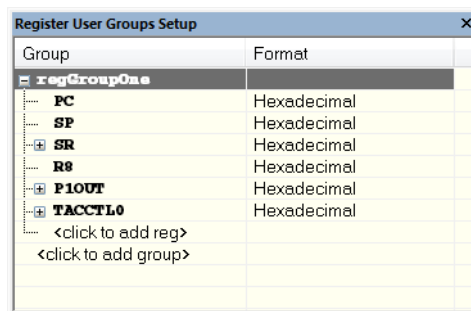

Use this window to define your own application-specific register groups. These register groups can then be viewed in the **Registers** windows.

Defining application-specific register groups means that the **Registers** windows can display just those registers that you need to watch for your current debugging task. This makes debugging much easier.

**Requirements**

None; this window is always available.

**Display area**

This area contains these columns:

**Group**

The names of register groups and the registers they contain. Clicking on <click to add group> or <click to add reg> and typing the name of a register group or register, adds new groups and registers, respectively. You can also drag a register name from another window in the IDE. Click a name to change it.

A dimmed register name indicates that it is not supported by the selected device.

**Format**

Shows the display format for the register's value. To change the display format of the value, right-click on the register and choose **Format** from the context menu. The selected format is used in all **Registers** windows.

**Context menu**

This context menu is available:

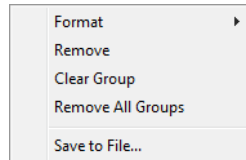

These commands are available:

**Format**

Changes the display format for the contents of the register you clicked on. The display format setting affects different types of registers in different ways. Your selection of display format is saved between debug sessions.

**Remove**

Removes the register or group you clicked on.

**Clear Group**

Removes all registers from the group you clicked on.

**Remove All Groups**

Deletes all user-defined register groups from your project.

**Save to File**

Opens a standard save dialog box to save the contents of the window to a tab-separated text file.

## SFR Setup window

The **SFR Setup** window is available from the **Project** menu.

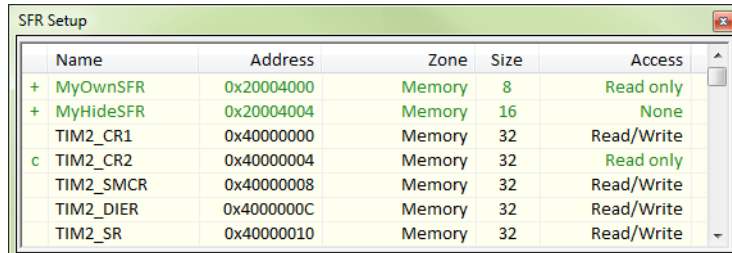

Name	Address	Zone	Size	Access
+ MyOwnSFR	0x20004000	Memory	8	Read only
+ MyHideSFR	0x20004004	Memory	16	None
TIM2_CR1	0x40000000	Memory	32	Read/Write
c TIM2_CR2	0x40000004	Memory	32	Read only
TIM2_SMCR	0x40000008	Memory	32	Read/Write
TIM2_DIER	0x4000000C	Memory	32	Read/Write
TIM2_SR	0x40000010	Memory	32	Read/Write

This window displays the currently defined SFRs that C-SPY has information about. You can choose to display only factory-defined or custom-defined SFRs, or both. If required, you can use the **Edit SFR** dialog box to customize the SFR definitions, see *Edit SFR dialog box*, page 167. For factory-defined SFRs (that is, retrieved from the `ddf` file in use), you can only customize the access type.

To quickly find an SFR, drag a text or hexadecimal number string and drop in this window. If what you drop starts with a 0 (zero), the **Address** column is searched, otherwise the **Name** column is searched.

Any custom-defined SFRs are added to a dedicated register group called Custom, which you can choose to display in the **Register** window. Your custom-defined SFRs are saved in `projectCustomSFR.sfr`. This file is automatically loaded in the IDE when you start C-SPY with a project whose name matches the prefix of the filename of the `sfr` file.

You can only add or modify SFRs when the C-SPY debugger is not running.

### Requirements

None; this window is always available.

### Display area

This area contains these columns:

#### Status

A character that signals the status of the SFR, which can be one of:  
blank, a factory-defined SFR.

C, a factory-defined SFR that has been modified.

+, a custom-defined SFR.

?, an SFR that is ignored for some reason. An SFR can be ignored when a factory-defined SFR has been modified, but the SFR is no longer available, or it is located somewhere else or with a different size. Typically, this might happen if you change to another device.

**Name**

A unique name of the SFR.

**Address**

The memory address of the SFR.

**Zone**

Selects a memory zone, see *C-SPY memory zones*, page 138.

**Size**

The size of the register, which can be any of **8**, **16**, **32**, or **64**.

**Access**

The access type of the register, which can be one of **Read/Write**, **Read only**, **Write only**, or **None**.

You can click a name or an address to change the value. The hexadecimal 0x prefix for the address can be omitted, the value you enter will still be interpreted as hexadecimal. For example, if you enter 4567, you will get 0x4567.

You can click a column header to sort the SFRs according to the column property.

Color coding used in the display area:

- Green, which indicates that the corresponding value has changed
- Red, which indicates an ignored SFR.

## Context menu

This context menu is available:

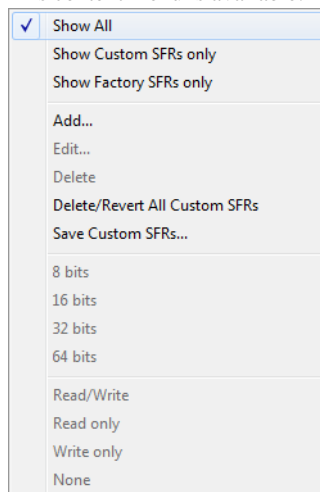

These commands are available:

### Show All

Shows all SFR.

### Show Custom SFRs only

Shows all custom-defined SFRs.

### Show Factory SFRs only

Shows all factory-defined SFRs retrieved from the ddf file.

### Add

Displays the **Edit SFR** dialog box where you can add a new SFR, see *Edit SFR dialog box*, page 167.

### Edit

Displays the **Edit SFR** dialog box where you can edit an SFR, see *Edit SFR dialog box*, page 167.

### Delete

Deletes an SFR. This command only works on custom-defined SFRs.

### Delete/revert All Custom SFRs

Deletes all custom-defined SFRs and reverts all modified factory-defined SFRs to their factory settings.

**Save Custom SFRs**

Opens a standard save dialog box to save all custom-defined SFRs.

**8|16|32|64 bits**

Selects display format for the selected SFR, which can be **8**, **16**, **32**, or **64** bits. Note that the display format can only be changed for custom-defined SFRs.

**Read/Write|Read only|Write only|None**

Selects the access type of the selected SFR, which can be **Read/Write**, **Read only**, **Write only**, or **None**. Note that for factory-defined SFRs, the default access type is indicated.

**Edit SFR dialog box**

The **Edit SFR** dialog box is available from the context menu in the **SFR Setup** window.

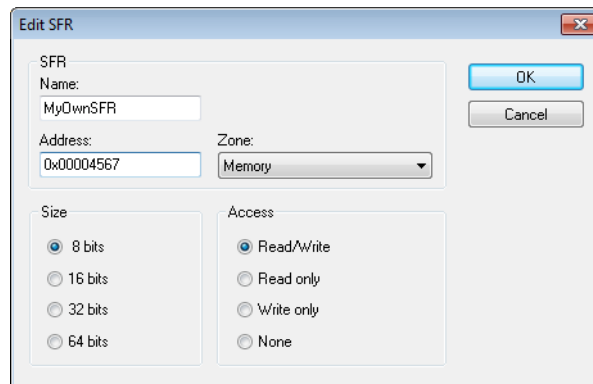

Definitions of the SFRs are retrieved from the device description file in use. Use this dialog box to either modify these factory-defined definitions or define new SFRs. See also *SFR Setup window*, page 164.

**Requirements**

None; this dialog box is always available.

**Name**

Specify the name of the SFR that you want to add or edit.

**Address**

Specify the address of the SFR that you want to add or edit. The hexadecimal 0x prefix for the address can be omitted, the value you enter will still be interpreted as hexadecimal. For example, if you enter 4567, you will get 0x4567.

**Zone**

Selects the memory zone for the SFR you want to add or edit. The list of zones is retrieved from the `adf` file that is currently used.

**Size**

Selects the size of the SFR. Choose between **8**, **16**, **32**, or **64** bits. Note that the display format can only be changed for custom-defined SFRs.

**Access**

Selects the access type of the SFR. Choose between **Read/Write**, **Read only**, **Write only**, or **None**. Note that for factory-defined SFRs, the default access type is indicated.



## Memory Access Setup dialog box

The **Memory Access Setup** dialog box is available from the C-SPY driver menu.

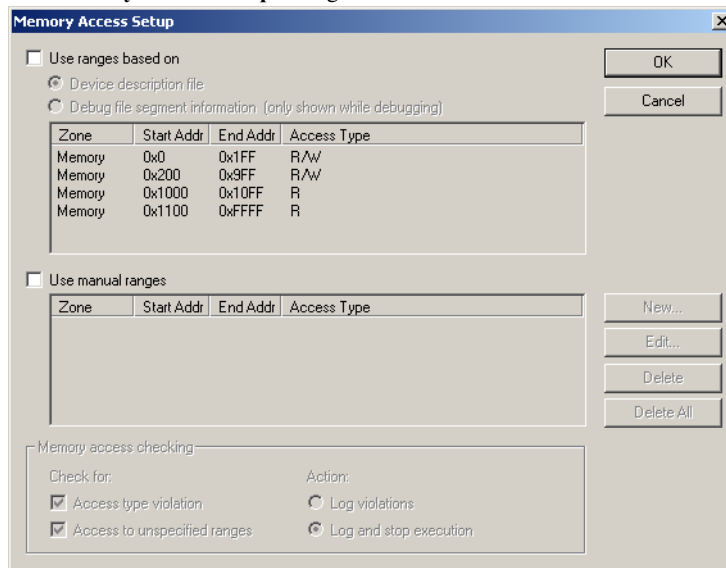

Use this dialog box to specify which set of memory address ranges to be used by C-SPY during debugging.

**Note:** If you enable both the **Use ranges based on** and the **Use manual ranges** option, memory accesses are checked for all defined ranges.

For information about the columns and the properties displayed, see *Edit Memory Access dialog box*, page 171. See also *Memory configuration for the C-SPY simulator*, page 139

### Requirements

The C-SPY simulator.

### Use ranges based on

Specify if the memory configuration should be retrieved from a predefined configuration. Choose between:

#### Device description file

Retrieves the memory configuration from the device description file that you have specified. See *Selecting a device description file*, page 44.

This option is used by default.

### Debug file segment information

Retrieves the memory configuration from the debug file, which has retrieved it from the linker configuration file. This information is only available during a debug session. The advantage of using this option is that the simulator can catch memory accesses outside the linked application.

### Use manual ranges

Specify your own ranges manually via the **Edit Memory Access** dialog box. To open this dialog box, click **New** to specify a new memory address range, or select an existing memory address range and choose **Edit** to modify it. For more information, see *Edit Memory Access dialog box*, page 171.

The ranges you define manually are saved between debug sessions.

### Memory access checking

**Check for** determines what to check for:

- **Access type violation**
- **Access to unspecified ranges**

**Action** selects the action to be performed if an access violation occurs. Choose between:

- **Log violations**
- **Log and stop execution**

Any violations are logged in the **Debug Log** window.

### Buttons

These buttons are available for manual ranges:

#### New

Opens the **Edit Memory Access** dialog box, where you can specify a new memory address range and associate an access type with it, see *Edit Memory Access dialog box*, page 171.

#### Edit

Opens the **Edit Memory Access** dialog box, where you can edit the selected memory address range. See *Edit Memory Access dialog box*, page 171.

#### Delete

Deletes the selected memory address range definition.

#### Delete All

Deletes all defined memory address range definitions.

## Edit Memory Access dialog box

The **Edit Memory Access** dialog box is available from the **Memory Access Setup** dialog box.

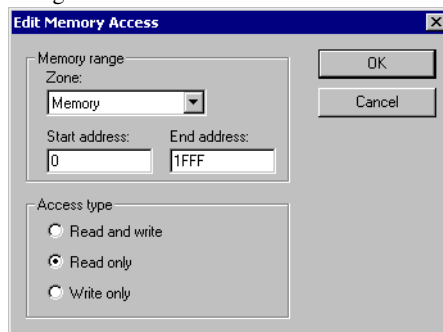

Use this dialog box to specify your memory address ranges for which you want to detect illegal accesses during the simulation, and assign an access type to each range.

### Requirements

The C-SPY simulator.

### Memory range

Defines the memory address range specific to your device:

#### Zone

Selects a memory zone, see *C-SPY memory zones*, page 138.

#### Start address

Specify the start address for the memory address range, in hexadecimal notation.

#### End address

Specify the end address for the memory address range, in hexadecimal notation.

### Access type

Selects an access type to the memory address range. Choose between:

- **Read and write**
- **Read only**
- **Write only**

## Memory Dump dialog box

The **Memory Dump** dialog box is available from the **Emulator** menu.

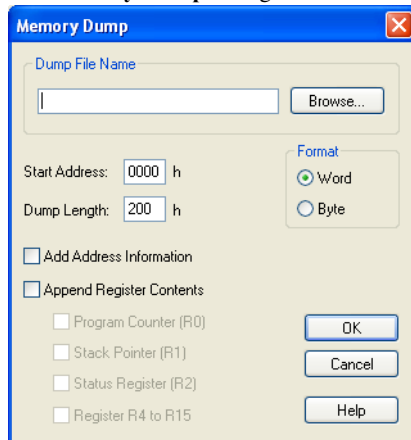

Use this dialog box to write memory contents to a file.

### Requirements

The C-SPY FET Debugger driver.

### Dump File Name

Specify the name of the destination file where the contents of the selected part of the memory will be saved in text format. You can find the file using the **Browse** button.

### Start Address

Specify the start address for the memory section you want to save to a file.

### Dump Length

Specify the length of the memory section you want to save to a file, in hexadecimal notation. The maximum length is FFFF, which limits the number of bytes that can be written to 65535. Consequently, you cannot write memory from address 0x0000 to 0xFFFF, inclusive, as this would require a length specifier of 65536 bytes (0x10000).

### Add address information

Adds address information to the file.

**Append register contents**

Appends register contents to the file. Choose between:

**Program Counter (R0)**

**Stack Pointer (R1)**

**Status Register (R2)**

**Register R4 to R15**

**Format**

Selects format for the text that is written to the file. Choose between:

**Word**

**Byte**



# Part 2. Analyzing your application

This part of the *C-SPY® Debugging Guide for MSP430* includes these chapters:

- Trace
- The application timeline
- Profiling
- Code coverage
- Power debugging

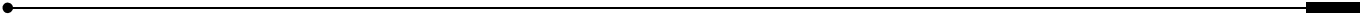
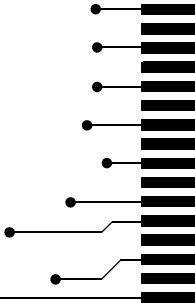

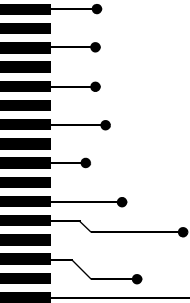



# Trace

- Introduction to using trace
- Collecting and using trace data
- Reference information on trace

---

## Introduction to using trace

These topics are covered:

- Reasons for using trace
- Briefly about trace
- Requirements for using trace

See also:

- *Getting started using data logging*, page 196
- *Power debugging*, page 235
- *Getting started using interrupt logging*, page 268
- *Profiling*, page 221
- *Using state storage*, page 292

### REASONS FOR USING TRACE

By using trace, you can inspect the program flow up to a specific state, for instance an application crash, and use the trace data to locate the origin of the problem. Trace data can be useful for locating programming errors that have irregular symptoms and occur sporadically.

### BRIEFLY ABOUT TRACE

To use trace in C-SPY requires that your target system can generate trace data. Once generated, C-SPY can collect it and you can visualize and analyze the data in various windows and dialog boxes.

Trace data is a continuously collected sequence of every executed instruction for a selected portion of the execution.

### Trace features in C-SPY

In C-SPY, you can use the trace-related windows **Trace**, **Function Trace**, **Timeline**, and **Find in Trace**.

Depending on your C-SPY driver, you:

- Can set various types of trace breakpoints to control the collection of trace data.
- Have access to windows such as the **Interrupt Log**, **Interrupt Log Summary**, **Data Log**, and **Data Log Summary**.

In addition, several other features in C-SPY also use trace data, features such as Profiling, Code coverage, and Instruction profiling.

### REQUIREMENTS FOR USING TRACE

The C-SPY simulator supports trace-related functionality, and there are no specific requirements.

Trace data cannot be collected from the hardware debugger systems.

---

## Collecting and using trace data

These tasks are covered:

- Getting started with trace
- Trace data collection using breakpoints
- Searching in trace data
- Browsing through trace data.

### GETTING STARTED WITH TRACE



- 1 After you have built your application and started C-SPY, open the **Trace** window—available from the driver-specific menu—and click the **Activate** button to enable collecting trace data.
- 2 Start the execution. When the execution stops, for example because a breakpoint is triggered, trace data is displayed in the **Trace** window. For more information about the window, see *Trace window*, page 180.

## TRACE DATA COLLECTION USING BREAKPOINTS

A convenient way to collect trace data between two execution points is to start and stop the data collection using dedicated breakpoints. Choose between these alternatives:

- In the editor or **Disassembly** window, position your insertion point, right-click, and toggle a **Trace Start** or **Trace Stop** breakpoint from the context menu.
- In the **Breakpoints** window, choose **Trace Start** or **Trace Stop**.
- The C-SPY system macros `__setTraceStartBreak` and `__setTraceStopBreak` can also be used.

For more information about these breakpoints, see *Trace Start breakpoints dialog box*, page 185 and *Trace Stop breakpoints dialog box*, page 186, respectively.

## SEARCHING IN TRACE DATA

When you have collected trace data, you can perform searches in the collected data to locate the parts of your code or data that you are interested in, for example, a specific interrupt or accesses of a specific variable.

You specify the search criteria in the **Find in Trace** dialog box and view the result in the **Find in Trace** window.

The **Find in Trace** window is very similar to the **Trace** window, showing the same columns and data, but *only* those rows that match the specified search criteria. Double-clicking an item in the **Find in Trace** window brings up the same item in the **Trace** window.

### To search in your trace data:



- 1 On the **Trace** window toolbar, click the **Find** button.
- 2 In the **Find in Trace** dialog box, specify your search criteria.

Typically, you can choose to search for:

- A specific piece of text, for which you can apply further search criteria
- An address range
- A combination of these, like a specific piece of text within a specific address range.

For more information about the various options, see *Find in Trace dialog box*, page 189.

- 3 When you have specified your search criteria, click **Find**. The **Find in Trace** window is displayed, which means you can start analyzing the trace data. For more information, see *Find in Trace window*, page 190.

## BROWSING THROUGH TRACE DATA

To follow the execution history, simply look and scroll in the **Trace** window. Alternatively, you can enter *browse mode*.



To enter browse mode, double-click an item in the **Trace** window, or click the **Browse** toolbar button.

The selected item turns yellow and the source and disassembly windows will highlight the corresponding location. You can now move around in the trace data using the up and down arrow keys, or by scrolling and clicking; the source and **Disassembly** windows will be updated to show the corresponding location. This is like stepping backward and forward through the execution history.

Double-click again to leave browse mode.

---

## Reference information on trace

Reference information about:

- *Trace window*, page 180
- *Function Trace window*, page 184
- *Trace Start breakpoints dialog box*, page 185
- *Trace Stop breakpoints dialog box*, page 186
- *Trace Expressions window*, page 187
- *Find in Trace dialog box*, page 189
- *Find in Trace window*, page 190.

## Trace window

The **Trace** window is available from the C-SPY driver menu.

This window displays the collected trace data.

See also *Collecting and using trace data*, page 178.

### Requirements

The C-SPY simulator.

## Trace toolbar

The toolbar in the **Trace** window and in the **Function Trace** window contains:



### Enable/Disable

Enables and disables collecting and viewing trace data in this window. This button is not available in the **Function Trace** window.



### Clear trace data

Clears the trace buffer. Both the **Trace** window and the **Function Trace** window are cleared.



### Toggle source

Toggles the **Trace** column between showing only disassembly or disassembly together with the corresponding source code.



### Browse

Toggles browse mode on or off for a selected item in the **Trace** window.



### Find

Displays a dialog box where you can perform a search, see *Find in Trace dialog box*, page 189.



### Save

Displays a standard **Save As** dialog box where you can save the collected trace data to a text file, with tab-separated columns.



### Edit Settings

In the C-SPY simulator, this button is not enabled.

### Edit Expressions (C-SPY simulator only)



Opens the **Trace Expressions** window, see *Trace Expressions window*, page 187.

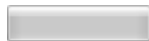

### Progress bar

When a large amount of trace data has been collected, there might be a delay before all of it has been processed and can be displayed. The progress bar reflects that processing.

## Display area

This area displays a collected sequence of executed machine instructions. In addition, the window can display trace data for expressions.

#	Cycles	Trace	callCount
1396	2766	FFF80574 MOV.L SP, R2	10
1397	2767	FFF80576 MOV #0x01:4, R1	10
1398	2771	FFF80578 BSR.A __DebugBreak	10
		__DebugBreak:	
1399	2777	FFF804E0 RTS	10
1400	2780	FFF8057C BRA.B 0xFFF80572	10
1401	2781	FFF80572 MOV.L R6, [SP]	10
1402	2782	FFF80574 MOV.L SP, R2	10
1403	2783	FFF80576 MOV #0x01:4, R1	10

This area contains these columns for the C-SPY simulator:

### #

A serial number for each row in the trace buffer. Simplifies the navigation within the buffer.

### Cycles

The number of cycles elapsed to this point.

### Trace

The collected sequence of executed machine instructions. Optionally, the corresponding source code can also be displayed.

### Expression

Each expression you have defined to be displayed appears in a separate column. Each entry in the expression column displays the value *after* executing the instruction on the same row. You specify the expressions for which you want to collect trace data in the **Trace Expressions** window, see *Trace Expressions window*, page 187.

A red-colored row indicates that the previous row and the red row are not consecutive. This means that there is a gap in the collected trace data, for example because trace data has been lost due to an overflow.

## Context menu

This context menu is available:

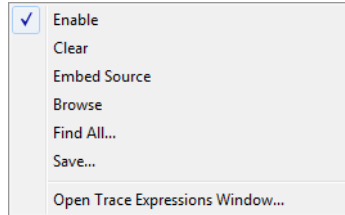

**Note:** The contents of this menu are dynamic and depend on which features that your combination of software and hardware supports. However, the list of menu commands below is complete and covers all possible commands.

These commands are available:

### Enable

Enables and disables collecting and viewing trace data in this window.

### Clear

Clears the trace buffer. Both the **Trace** window and the **Function Trace** window are cleared.

### Embed source

Toggles the **Trace** column between showing only disassembly or disassembly together with the corresponding source code.

### Browse

Toggles browse mode on or off for a selected item in the **Trace** window.

### Find All

Displays a dialog box where you can perform a search in the Trace window, see *Find in Trace dialog box*, page 189. The search results are displayed in the **Find in Trace** window—available by choosing the **View>Messages** command, see *Find in Trace window*, page 190.

### Save

Displays a standard **Save As** dialog box where you can save the collected trace data to a text file, with tab-separated columns.

### Open Trace Expressions Window

Opens the **Trace Expressions** window, see *Trace Expressions window*, page 187.

## Function Trace window

The **Function Trace** window is available from the C-SPY driver menu during a debug session.

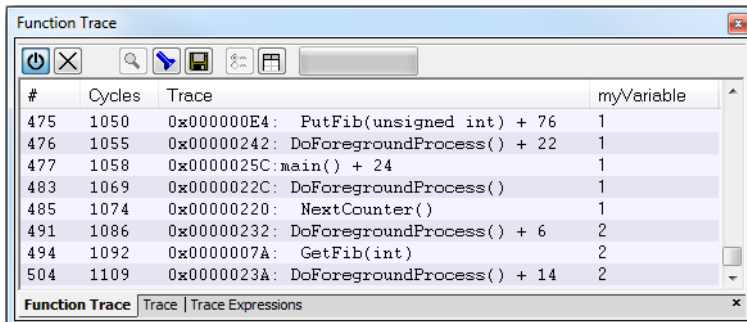

This window displays a subset of the trace data displayed in the **Trace** window. Instead of displaying all rows, the **Function Trace** window shows:

- The functions called or returned to, instead of the traced instruction
- The corresponding trace data.

### Requirements

The C-SPY simulator.

### Toolbar

For information about the toolbar, see *Trace window*, page 180.

### Display area

For information about the columns in the display area, see *Trace window*, page 180



## Trace Start breakpoints dialog box

The **Trace Start** dialog box is available from the context menu that appears when you right-click in the **Breakpoints** window.

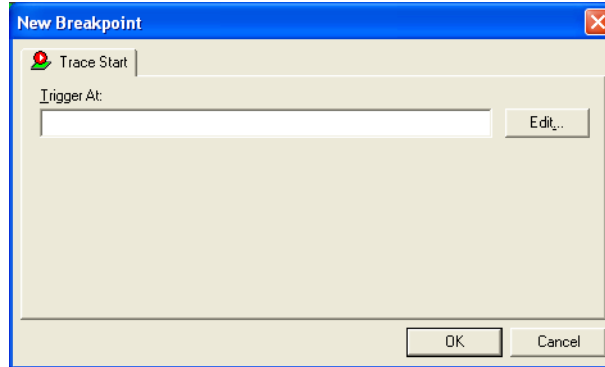

Use this dialog box to set a Trace Start breakpoint where you want to start collecting trace data. If you want to collect trace data only for a specific range, you must also set a Trace Stop breakpoint where you want to stop collecting data.

See also *Trace Stop breakpoints dialog box*, page 186 and *Trace data collection using breakpoints*, page 179.

### To set a Trace Start breakpoint:

- 1 In the editor or **Disassembly** window, right-click and choose **Trace Start** from the context menu.  
Alternatively, open the **Breakpoints** window by choosing **View>Breakpoints**.
- 2 In the **Breakpoints** window, right-click and choose **New Breakpoint>Trace Start**.  
Alternatively, to modify an existing breakpoint, select a breakpoint in the **Breakpoints** window and choose **Edit** on the context menu.
- 3 In the **Trigger At** text box, specify an expression, an absolute address, or a source location. Click **OK**.
- 4 When the breakpoint is triggered, the trace data collection starts.

### Requirements

The C-SPY simulator.

### Trigger at

Specify the code location of the breakpoint. Alternatively, click the **Edit** button to open the **Enter Location** dialog box, see *Enter Location dialog box*, page 132.

## Trace Stop breakpoints dialog box

The **Trace Stop** dialog box is available from the context menu that appears when you right-click in the **Breakpoints** window.

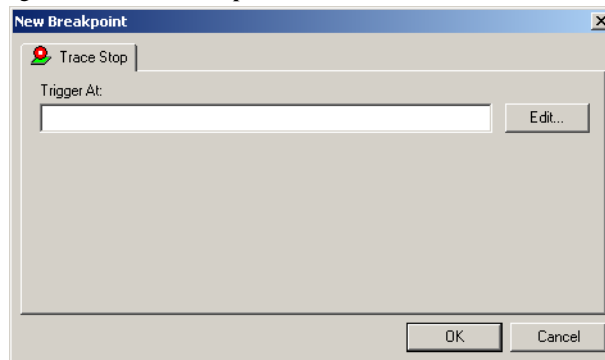

Use this dialog box to set a Trace Stop breakpoint where you want to stop collecting trace data. If you want to collect trace data only for a specific range, you might also need to set a Trace Start breakpoint where you want to start collecting data.

See also *Trace Start breakpoints dialog box*, page 185 and *Trace data collection using breakpoints*, page 179.

### To set a Trace Stop breakpoint:

- 1 In the editor or **Disassembly** window, right-click and choose **Trace Stop** from the context menu.  
Alternatively, open the **Breakpoints** window by choosing **View>Breakpoints**.
- 2 In the **Breakpoints** window, right-click and choose **New Breakpoint>Trace Stop**.  
Alternatively, to modify an existing breakpoint, select a breakpoint in the **Breakpoints** window and choose **Edit** on the context menu.
- 3 In the **Trigger At** text box, specify an expression, an absolute address, or a source location. Click **OK**.
- 4 When the breakpoint is triggered, the trace data collection stops.

### Requirements

The C-SPY simulator.

### Trigger at

Specify the code location of the breakpoint. Alternatively, click the **Edit** button to open the **Enter Location** dialog box, see *Enter Location dialog box*, page 132.

## Trace Expressions window

The **Trace Expressions** window is available from the **Trace** window toolbar.

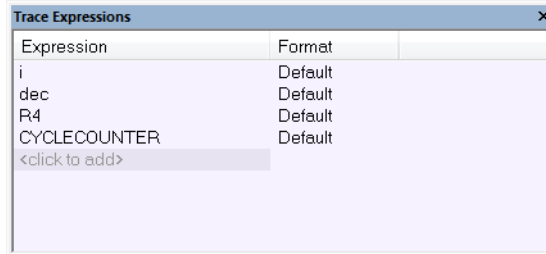

Use this window to specify, for example, a specific variable (or an expression) for which you want to collect trace data.

### Requirements

The C-SPY simulator.

### Display area

Use the display area to specify expressions for which you want to collect trace data:

#### Expression

Specify any expression that you want to collect data from. You can specify any expression that can be evaluated, such as variables and registers.

#### Format

Shows which display format that is used for each expression. Note that you can change display format via the context menu.

Each row in this area will appear as an extra column in the **Trace** window.

## Context menu

This context menu is available:

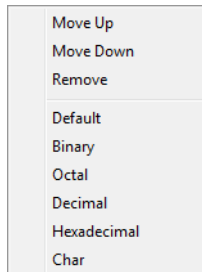

These commands are available:

### Move Up

Moves the selected expression upward in the window.

### Move Down

Moves the selected expression downward in the window.

### Remove

Removes the selected expression from the window.

### Default Format, Binary Format, Octal Format, Decimal Format, Hexadecimal Format, Char Format

Changes the display format of expressions. The display format setting affects different types of expressions in different ways. Your selection of display format is saved between debug sessions. These commands are available if a selected line in the window contains a variable.

The display format setting affects different types of expressions in these ways:

Variables	The display setting affects only the selected variable, not other variables.
Array elements	The display setting affects the complete array, that is, the same display format is used for each array element.
Structure fields	All elements with the same definition—the same field name and C declaration type—are affected by the display setting.

## Find in Trace dialog box

The **Find in Trace** dialog box is available by clicking the **Find** button on the **Trace** window toolbar or by choosing **Edit>Find and Replace>Find**.

Note that the **Edit>Find and Replace>Find** command is context-dependent. It displays the **Find in Trace** dialog box if the **Trace** window is the current window or the **Find** dialog box if the editor window is the current window.

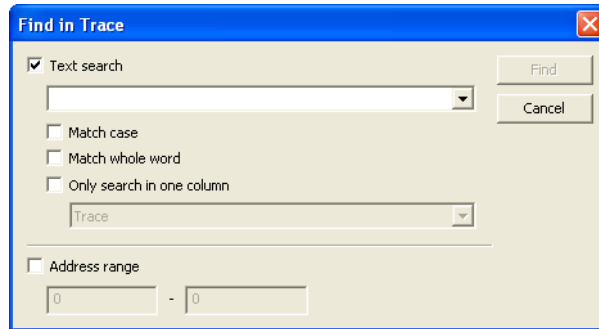

Use this dialog box to specify the search criteria for advanced searches in the trace data.

The search results are displayed in the **Find in Trace** window—available by choosing the **View>Messages** command, see *Find in Trace window*, page 190.

See also *Searching in trace data*, page 179.

### Requirements

The C-SPY simulator.

### Text search

Specify the string you want to search for. To specify the search criteria, choose between:

#### Match Case

Searches only for occurrences that exactly match the case of the specified text. Otherwise **int** will also find **INT** and **Int** and so on.

#### Match whole word

Searches only for the string when it occurs as a separate word. Otherwise **int** will also find **print**, **sprintf** and so on.

#### Only search in one column

Searches only in the column you selected from the drop-down list.

## Address Range

Specify the address range you want to display or search. The trace data within the address range is displayed. If you also have specified a text string in the **Text search** field, the text string is searched for within the address range.

## Find in Trace window

The **Find in Trace** window is available from the **View>Messages** menu. Alternatively, it is automatically displayed when you perform a search using the **Find in Trace** dialog box or perform a search using the **Find in Trace** command available from the context menu in the editor window.

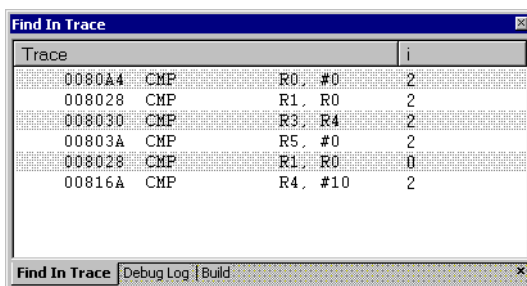

The screenshot shows a window titled "Find In Trace" with a table of trace data. The table has two columns: "Trace" and "i". The data rows are as follows:

Trace	i
0080A4 CMP R0, #0	2
008028 CMP R1, R0	2
008030 CMP R3, R4	2
00803A CMP R5, #0	2
008028 CMP R1, R0	0
00816A CMP R4, #10	2

The window also has a status bar at the bottom with the text "Find In Trace | Debug Log | Build" and a close button (X).

This window displays the result of searches in the trace data. Double-click an item in the **Find in Trace** window to bring up the same item in the **Trace** window.

Before you can view any trace data, you must specify the search criteria in the **Find in Trace** dialog box, see *Find in Trace dialog box*, page 189.

See also *Searching in trace data*, page 179.

## Requirements

The C-SPY simulator.

## Display area

The **Find in Trace** window looks like the **Trace** window and shows the same columns and data, but *only* those rows that match the specified search criteria.

# The application timeline

- Introduction to analyzing your application's timeline
- Analyzing your application's timeline
- Reference information on application timeline

---

## Introduction to analyzing your application's timeline

These topics are covered:

- Briefly about analyzing the timeline
- Requirements for timeline support

See also:

- *Trace*, page 177

### BRIEFLY ABOUT ANALYZING THE TIMELINE

C-SPY can provide information for various aspects of your application, collected when the application is running. This can help you to analyze the application's behavior.

You can view the timeline information in different representations:

- As different *graphs* that correlate with the running application in relation to a shared *time axis*.
- As detailed logs
- As summaries of the logs.

Depending on the capabilities of your hardware, the debug probe, and the C-SPY driver you are using, timeline information can be provided for:

**Call stack** Can be represented in the **Timeline** window, as a graph that displays the sequence of function calls and returns collected by the trace system. You get timing information between the function invocations.

Note that there is also a related **Call Stack** window and a **Function Trace** window, see *Call Stack window*, page 71 and *Function Trace window*, page 184, respectively.

- Data logging** Based on data logs collected by the trace system for up to four different variables or address ranges, specified by means of *Data Log breakpoints*. Choose to display the data logs:
- In the **Timeline** window, as a graph of how the values change over time.
  - In the **Data Log** window and the **Data Log Summary** window.
- Interrupt logging** Based on interrupt logs collected by the trace system. Choose to display the interrupt logs:
- In the **Timeline** window, as a graph of the interrupt events during the execution of your application.
  - In the **Interrupt Log** window and the **Interrupt Log Summary** window.
- Interrupt logging can, for example, help you locate which interrupts you can fine-tune to make your application more efficient. For more information, see the chapter *Interrupts*.
- Power logging** Based on logged power measurement samples generated by the debug probe or associated hardware. Choose to display the power logs:
- In the **Timeline** window, as a graph of the power measurement samples. You can choose to display graphs for current, voltage, and energy.
  - In the **Power Log** window.
- Power logs can be useful for finding peaks in the power consumption and by double-clicking on a value you can see the corresponding source code. The precision depends on the frequency of the samples, but there is a good chance that you find the source code sequence that caused the peak.
- For more information, see the chapter *Power debugging*, page 235.
- State logging** Based on logged activity—state changes—for peripheral units and clocks, as well as for CPU modes generated by the debug probe or associated hardware. Choose to display the state logs:
- In the **Timeline** window, as a graph of the state changes.
  - In the **State Log** window and in the **State Log Summary** window.
- The information is useful for tracing the activity on the target system.
- For more information, see the chapter *Power debugging*, page 235.



## REQUIREMENTS FOR TIMELINE SUPPORT

Target system	Call Stack	Data logging		Interrupt logging	Power logging
C-SPY simulator	Yes	Yes	—	Yes	—

Table 7: Support for timeline information

Depending on the capabilities of the hardware, the debug probe, and the C-SPY driver you are using, trace-based timeline information is supported for:

Target system	Call Stack	Data logging	Interrupt logging	State logging	Power logging
C-SPY simulator	Yes	Yes	Yes		—
C-SPY FET Debugger driver	—	—	—	Yes	Yes

Table 8: Supported graphs in the Timeline window

For more information about requirements related to trace data, see *Requirements for using trace*, page 178.

---

## Analyzing your application's timeline

These tasks are covered:

- *Displaying a graph in the Timeline window*, page 194
- *Navigating in the graphs*, page 194
- *Analyzing performance using the graph data*, page 195
- *Getting started using data logging*, page 196
- *Getting started using data sampling*, page 197

See also:

- *Debugging in the power domain*, page 242
- *Using the interrupt system*, page 265

## DISPLAYING A GRAPH IN THE TIMELINE WINDOW

The **Timeline** window can display several graphs; follow this example procedure to display any of these graphs. For an overview of the graphs and what they display, see *Briefly about analyzing the timeline*, page 191.

- 1 Choose **Project>Options>FET Debugger>Setup** and select **Enable ULP/LPMx.5 debug**.  
If you are using the C-SPY simulator, choose **Simulator>Simulated Frequency** to set up a frequency that matches the simulated hardware.
- 2 Start C-SPY.
- 3 Choose **Timeline** from the C-SPY driver menu to open the **Timeline** window.
- 4 In the **Timeline** window, right-click in the window and choose **Select graphs** from the context menu to select which graphs to be displayed.
- 5 In the **Timeline** window, right-click in the graph area and choose **Enable** from the context menu to enable a specific graph.
- 6 For the Data Log graph, you must set a Data Log breakpoint for each variable you want a graphical representation of in the **Timeline** window. See *Data Log breakpoints dialog box*, page 123.
- 7 Click **Go** on the toolbar to start executing your application. The graphs that you have enabled appear.

## NAVIGATING IN THE GRAPHS

After you have performed the steps in *Displaying a graph in the Timeline window*, page 194, you can use any of these alternatives to navigate in the graph:

- Right-click and from the context menu choose **Zoom In** or **Zoom Out**.  
Alternatively, use the + and – keys. The graph zooms in or out depending on which command you used.
- Right-click in the graph and from the context menu choose **Navigate** and the appropriate command to move backwards and forwards on the graph. Alternatively, use any of the shortcut keys: arrow keys, Home, End, and Ctrl+End.
- Double-click on a sample of interest to highlight the corresponding source code in the editor window and in the **Disassembly** window.
- Click on the graph and drag to select a time interval, which will correlate to the running application. The selection extends vertically over all graphs, but appears highlighted in a darker color for the selected graph. Press Enter or right-click and

from the context menu choose **Zoom>Zoom to Selection**. The selection zooms in. Use the navigation keys in combination with the Shift key to extend the selection.

## ANALYZING PERFORMANCE USING THE GRAPH DATA

The **Timeline** window provides a set of tools for analyzing the graph data.

- 1 In the **Timeline** window, right-click and choose **Time Axis Unit** from the context menu. Select which unit to be used on the time axis; choose between **Seconds** and **Cycles**. If **Cycles** is not available, the graphs are based on different clock sources.
- 2 Execute your application to display a graph, following the steps described in *Displaying a graph in the Timeline window*, page 194.
- 3 Whenever execution stops, point at the graph with the mouse pointer to get detailed tooltip information for that location.

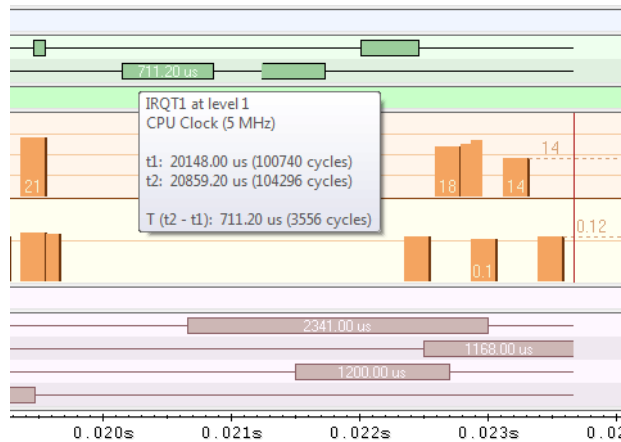

Note that if you have enabled several graphs, you can move the mouse pointer over the different graphs to get graph-specific information.

- 4 Click in the graph and drag to select a time interval. Point in the graph with the mouse pointer to get timing information for the selection.

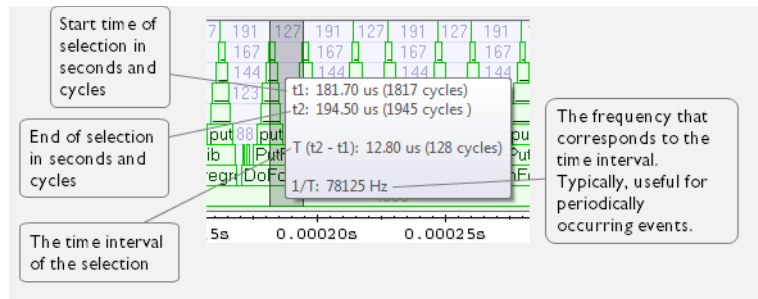

## GETTING STARTED USING DATA LOGGING

- 1 To set a data log breakpoint, use one of these methods:
  - In the **Breakpoints** window, right-click and choose **New Breakpoint>Data Log** to open the breakpoints dialog box. Set a breakpoint on the memory location that you want to collect log information for. This can be specified either as a variable or as an address.
  - In the **Memory** window, select a memory area, right-click and choose **Set Data Log Breakpoint** from the context menu. A breakpoint is set on the start address of the selection.
  - In the editor window, select a variable, right-click and choose **Set Data Log Breakpoint** from the context menu. The breakpoint will be set on the part of the variable that the microcontroller can access using one instruction.

You can set up to four data log breakpoints. For more information about data log breakpoints, see *Data Log breakpoints*, page 105.
- 2 Choose **C-SPY driver>Data Log** to open the **Data Log** window. Optionally, you can also choose:
  - **C-SPY driver>Data Log Summary** to open the **Data Log Summary** window
  - **C-SPY driver>Timeline** to open the **Timeline** window to view the Data Log graph.
- 3 From the context menu, available in the **Data Log** window, choose **Enable** to enable the logging.
- 4 Start executing your application program to collect the log information.
- 5 To view the data log information, look in the **Data Log** window, the **Data Log Summary** window, or the Data graph in the **Timeline** window.

- 6 If you want to save the log or summary to a file, choose **Save to log file** from the context menu in the window in question.
- 7 To disable data logging, choose **Disable** from the context menu in each window where you have enabled it.

## GETTING STARTED USING DATA SAMPLING

- 1 Choose *C-SPY driver*>**Data Sample Setup** to open the **Data Sample Setup** window.
- 2 In the **Data Sample Setup** window, perform these actions:
  - In the **Expression** column, type the name of the variable for which you want to sample data. The variable must be an integral type with a maximum size of 32 bits and you can specify up to four variables. Make sure that the checkbox is selected for the variable that you want to sample.
  - In the **Sampling interval** column, type the number of milliseconds to pass between the samples.
- 3 To view the result of data sampling, you must enable it in the window in question:
  - Choose *C-SPY driver*>**Data Sample** to open the **Data Sample** window. From the context menu, choose **Enable**.
  - Choose *C-SPY driver*>**Sampled Graphs** to open the **Sampled Graphs** window. From the context menu, choose **Enable**.
- 4 Start executing your application program. This starts the data sampling. When the execution stops, for example because a breakpoint is triggered, you can view the result either in the **Data Sample** window or as the Data Sample graph in the **Sampled Graphs** window
- 5 If you want to save the log or summary to a file, choose **Save to log file** from the context menu in the window in question.
- 6 To disable data sampling, choose **Disable** from the context menu in each window where you have enabled it.

---

## Reference information on application timeline

Reference information about:

- *Timeline window—Call Stack graph*, page 198
- *Timeline window—Data Log graph*, page 201
- *Data Log window*, page 205
- *Data Log Summary window*, page 208

- *Viewing Range dialog box*, page 218

See also:

- *Timeline window—Interrupt Log graph*, page 280
- *Interrupt Log window*, page 275
- *Interrupt Log Summary window*, page 277
- *Power graph in the Timeline window*, page 251
- *Power Log window*, page 248
- *Timeline window—State Log graph*, page 257
- *State Log window*, page 252
- *State Log Summary window*, page 254

## Timeline window—Call Stack graph

The **Timeline** window is available from the *C-SPY driver* menu during a debug session.

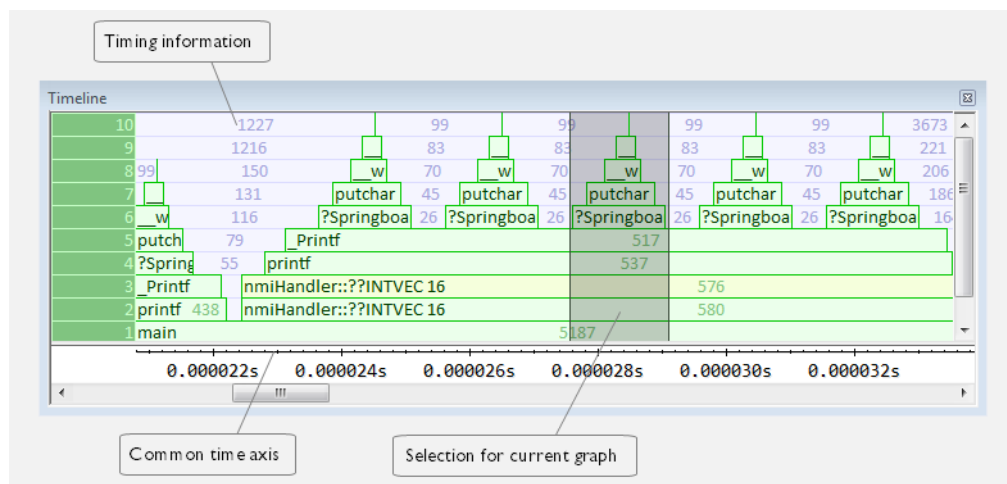

This window displays trace data represented as different graphs, in relation to a shared time axis.

The Call Stack graph displays the sequence of function calls and returns collected by the trace system.

**Note:** There is a limit on the number of saved logs. When this limit is exceeded, the oldest entries in the buffer are erased.

## Requirements

The C-SPY simulator.

## Display area for the Call Stack graph

Each function invocation is displayed as a horizontal bar which extends from the time of entry until the return. Called functions are displayed above its caller. The horizontal bars use four different colors:

- Medium green for normal C functions with debug information
- Light green for functions known to the debugger only through an assembler label
- Medium yellow for normal interrupt handlers, with debug information
- Light yellow for interrupt handlers known to the debugger only through an assembler label

The timing information represents the number of cycles spent in, or between, the function invocations.

At the bottom of the window, there is a shared time axis that uses seconds or cycles as the time unit.

Click in the graph to display the corresponding source code.

## Context menu

This context menu is available:

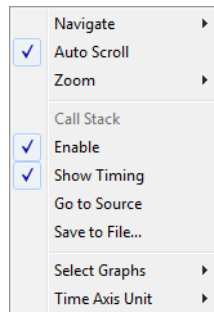

**Note:** The contents of this menu are dynamic and depend on which features that your combination of software and hardware supports. However, the list of menu commands below is complete and covers all possible commands.

These commands are available:

### Navigate

Commands for navigating the graph(s). Choose between:

**Next** moves the selection to the next relevant point in the graph. Shortcut key: right arrow.

**Previous** moves the selection backward to the previous relevant point in the graph. Shortcut key: left arrow.

**First** moves the selection to the first data entry in the graph. Shortcut key: Home.

**Last** moves the selection to the last data entry in the graph. Shortcut key: End.

**End** moves the selection to the last data in any displayed graph, in other words the end of the time axis. Shortcut key: Ctrl+End.

### Auto Scroll

Toggles automatic scrolling on or off. When on, the most recently collected data is automatically displayed when you choose **Navigate>End**.

### Zoom

Commands for zooming the window, in other words, changing the time scale. Choose between:

**Zoom to Selection** makes the current selection fit the window. Shortcut key: Return.

**Zoom In** zooms in on the time scale. Shortcut key: +.

**Zoom Out** zooms out on the time scale. Shortcut key: -.

**10ns, 100ns, 1us**, etc makes an interval of 10 nanoseconds, 100 nanoseconds, 1 microsecond, respectively, fit the window.

**1ms, 10ms**, etc makes an interval of 1 millisecond or 10 milliseconds, respectively, fit the window.

**10m, 1h**, etc makes an interval of 10 minutes or 1 hour, respectively, fit the window.

### Call Stack

A heading that shows that the Call stack-specific commands below are available.

### Enable

Toggles the display of the graph on or off. If you disable a graph, that graph will be indicated as **OFF** in the window. If no data has been collected for a graph, **no data** will appear instead of the graph.



**Show Timing**

Toggles the display of the timing information on or off.

**Go To Source**

Displays the corresponding source code in an editor window, if applicable.

**Save to File**

Saves all contents (or the selected contents) of the Call Stack graph to a file. The menu command is only available when C-SPY is not running.

**Select Graphs**

Selects which graphs to be displayed in the **Timeline** window.

**Time Axis Unit**

Selects the unit used in the time axis; choose between **Seconds** and **Cycles**.

If **Cycles** is not available, the graphs are based on different clock sources. In that case you can view cycle values as tooltip information by pointing at the graph with your mouse pointer.

**Profile Selection**

Enables profiling time intervals in the **Function Profiler** window. Note that this command is only available if the C-SPY driver supports PC Sampling.

**Timeline window—Data Log graph**

The **Timeline** window is available from the C-SPY driver menu during a debug session.

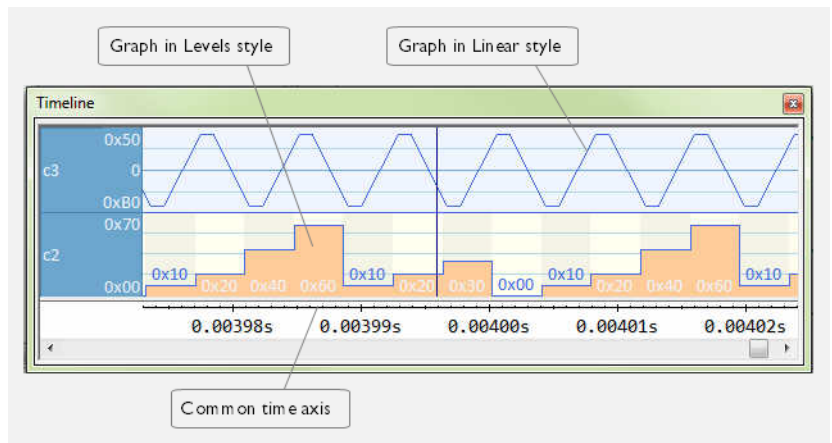

This window displays trace data represented as different graphs, in relation to a shared time axis.

The Data Log graph displays the data logs collected by the trace system, for up to four different variables or address ranges specified as Data Log breakpoints.

**Note:** There is a limit on the number of saved logs. When this limit is exceeded, the oldest entries in the buffer are erased.

## Requirements

The C-SPY simulator.

### Display area for the Data Log graph

Where:

- The label area at the left end of the graph displays the variable name or the address for which you have specified the Data Log breakpoint.
- The graph itself displays how the value of the variable changes over time. The label area also displays the limits, or range, of the Y-axis for a variable. You can use the context menu to change these limits. The graph is a graphical representation of the information in the **Data Log** window, see *Data Log window*, page 205.
- The graph can be displayed either as a thin line between consecutive logs or as a rectangle for every log (optionally color-filled).
- A red vertical line indicates overflow, which means that the communication channel failed to transmit all data logs from the target system. A red question mark indicates a log without a value.

At the bottom of the window, there is a shared time axis that uses seconds or cycles as the time unit.

## Context menu

This context menu is available:

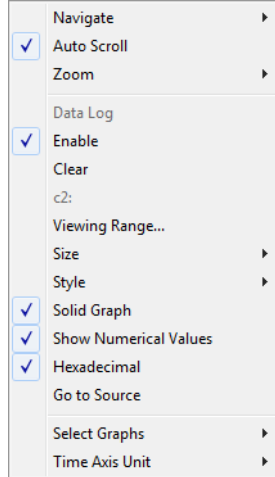

**Note:** The contents of this menu are dynamic and depend on which features that your combination of software and hardware supports. However, the list of menu commands below is complete and covers all possible commands.

These commands are available:

### Navigate

Commands for navigating the graph(s). Choose between:

**Next** moves the selection to the next relevant point in the graph. Shortcut key: right arrow.

**Previous** moves the selection backward to the previous relevant point in the graph. Shortcut key: left arrow.

**First** moves the selection to the first data entry in the graph. Shortcut key: Home.

**Last** moves the selection to the last data entry in the graph. Shortcut key: End.

**End** moves the selection to the last data in any displayed graph, in other words the end of the time axis. Shortcut key: Ctrl+End.

### Auto Scroll

Toggles automatic scrolling on or off. When on, the most recently collected data is automatically displayed when you choose **Navigate>End**.

### **Zoom**

Commands for zooming the window, in other words, changing the time scale. Choose between:

**Zoom to Selection** makes the current selection fit the window. Shortcut key: Return.

**Zoom In** zooms in on the time scale. Shortcut key: +.

**Zoom Out** zooms out on the time scale. Shortcut key: -.

**10ns, 100ns, 1us**, etc makes an interval of 10 nanoseconds, 100 nanoseconds, 1 microsecond, respectively, fit the window.

**1ms, 10ms**, etc makes an interval of 1 millisecond or 10 milliseconds, respectively, fit the window.

**10m, 1h**, etc makes an interval of 10 minutes or 1 hour, respectively, fit the window.

### **Data Log**

A heading that shows that the Data Log-specific commands below are available.

#### **Enable**

Toggles the display of the graph on or off. If you disable a graph, that graph will be indicated as **OFF** in the window. If no data has been collected for a graph, **no data** will appear instead of the graph.

#### **Clear**

Deletes the log information. Note that this will happen also when you reset the debugger.

#### *Variable*

The name of the variable for which the Data Log-specific commands below apply. This menu command is context-sensitive, which means it reflects the Data Log graph you selected in the **Timeline** window (one of up to four).

#### **Viewing Range**

Displays a dialog box, see *Viewing Range dialog box*, page 218.

#### **Size**

Determines the vertical size of the graph; choose between **Small**, **Medium**, and **Large**.

#### **Solid Graph**

Displays the graph as a color-filled solid graph instead of as a thin line.

**Show Numerical Value**

Shows the numerical value of the variable, in addition to the graph.

**Hexadecimal**

Toggles between displaying the selected value in decimal or hexadecimal format. Note that this setting also affects the log window.

**Go To Source**

Displays the corresponding source code in an editor window, if applicable.

**Select Graphs**

Selects which graphs to be displayed in the **Timeline** window.

**Time Axis Unit**

Selects the unit used in the time axis; choose between **Seconds** and **Cycles**.

If **Cycles** is not available, the graphs are based on different clock sources. In that case you can view cycle values as tooltip information by pointing at the graph with your mouse pointer.

**Data Log window**

The **Data Log** window is available from the C-SPY driver menu.

Time	Program Counter	I1	Address	s2	Address
0.160us	---			W 0x0000	@ 0x2004
0.160us	0xFFE00049	-	@ 0x2000		
24.480us	0xFFE000B5			R 0x0000	@ 0x2006
24.720us	0xFFE000BF			W 0x0042	@ 0x2004
24.760us	0xFFE000C6			R 0x0042	@ 0x2006
24.960us	0xFFE000E4	W 0x00004444	@ 0x2000		
78.760us	0xFFE00104			R 0x0042	@ 0x2004+?
79.000us	---			W 0x0084	@ 0x2004
100.800us	0xFFE00104			R 0x0084	@ 0x2006
101.040us	0xFFE0010E			W 0x00C6	@ 0x2004
136.640us	<b>Overflow</b>				
136.880us	0xFFE0010E			-	@ 0x2004

White rows indicate read accesses

Grey rows indicate write accesses

Use this window to log accesses to up to four different memory locations or areas.

**Note:** There is a limit on the number of saved logs. When this limit is exceeded, the oldest entries in the buffer are erased.

See also *Getting started using data logging*, page 196.

## Requirements

The C-SPY simulator.

## Display area

Each row in the display area shows the time, the program counter, and, for every tracked data object, its value and address. All information is cleared on reset. The information is displayed in these columns:

### Time

If the time is displayed in italics, the target system has not been able to collect a correct time, but instead had to approximate it.

This column is available when you have selected **Show time** from the context menu.

### Cycles

The number of cycles from the start of the execution until the event.

If a cycle is displayed in italics, the target system has not been able to collect a correct time, but instead had to approximate it.

This column is available when you have selected **Show cycles** from the context menu.

### Program Counter\*

Displays one of these:

An address, which is the content of the PC, that is, the address of the instruction that performed the memory access.

---, the target system failed to provide the debugger with any information.

**Overflow** in red, the communication channel failed to transmit all data from the target system.

### Value

Displays the access type and the value (using the access size) for the location or area you want to log accesses to. For example, if zero is read using a byte access it will be displayed as 0x00, and for a long access it will be displayed as 0x00000000.

To specify what data you want to log accesses to, use the **Data Log** breakpoint dialog box. See *Data Log breakpoints*, page 105.

## Address

The actual memory address that is accessed. For example, if only a byte of a word is accessed, only the address of the byte is displayed. The address is calculated as base address + offset, where the base address is retrieved from the **Data Log** breakpoint dialog box and the offset is retrieved from the logs. If the log from the target system does not provide the debugger with an offset, the offset contains + ?.

\* You can double-click a line in the display area. If the value of the PC for that line is available in the source code, the editor window displays the corresponding source code (this does not include library source code).

## Context menu

This context menu is available:

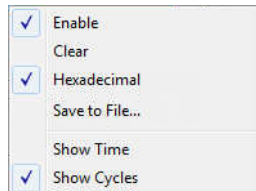

These commands are available:

### Enable

Enables the logging system. The system will log information also when the window is closed.

### Clear

Deletes the log information. Note that this will happen also when you reset the debugger.

### Hexadecimal

Toggles between displaying the selected value in decimal or hexadecimal format. Note that this setting also affects the log window.

### Save to File

Displays a standard file selection dialog box where you can select the destination file for the log information. The entries in the log file are separated by TAB and LF characters. An X in the **Approx** column indicates that the timestamp is an approximation.

### Show Time

Displays the **Time** column.

If the **Time** column is displayed by default in the C-SPY driver you are using, this menu command is not available.

### Show Cycles

Displays the **Cycles** column.

If the **Cycles** column is not supported in the C-SPY driver you are using, this menu command is not available.

## Data Log Summary window

The **Data Log Summary** window is available from the C-SPY driver menu.

Data	Total Accesses	Read Accesses	Write Accesses	Unknown Accesses
tVar1	42	0	25	17
tVar2	66	17	49	0
tVar3	32	32	0	0

Approximative time count: 16  
 Overflow count: 8  
 Current time: 4301.52 us

This window displays a summary of data accesses to specific memory location or areas.

See also *Getting started using data logging*, page 196.

### Requirements

The C-SPY simulator.

### Display area

Each row in this area displays the type and the number of accesses to each memory location or area in these columns. Summary information is listed at the bottom of the display area.

#### Data

The name of the data object you have selected to log accesses to. To specify what data object you want to log accesses to, use the **Data Log** breakpoint dialog box. See *Data Log breakpoints*, page 105.

#### Total Accesses

The total number of accesses.



If the sum of read accesses and write accesses is less than the total accesses, the target system for some reason did not provide valid access type information for all accesses.

**Read Accesses**

The total number of read accesses.

**Write Accesses**

The total number of write accesses.

**Unknown Accesses**

The number of unknown accesses, in other words, accesses where the access type is not known.

**Approximative time count**

The information displayed depends on the C-SPY driver you are using.

For some C-SPY drivers, this information is not displayed or the value is always zero. In this case, all logs have an exact time stamp.

For other C-SPY drivers, a non-zero value is displayed. The value represents the amount of logs with an approximative time stamp. This might happen if the bandwidth in the communication channel is too low compared to the amount of data packets generated by the CPU or if the CPU generated packets with an approximative time stamp.

**Overflow count**

The information displayed depends on the C-SPY driver you are using.

For some C-SPY drivers, this information is not displayed or the value is always zero.

For other C-SPY drivers, the number represents the amount of overflows in the communication channel which can cause logs to be lost. If this happens, it indicates that logs might be incomplete. To solve this, make sure not to use all C-SPY log features simultaneously or check used bandwidth for the communication channel.

**Current time|cycles**

The information displayed depends on the C-SPY driver you are using.

For some C-SPY drivers, the value is always zero or not visible at all.

For other C-SPY drivers, the number represents the current time or cycles—the number of cycles or the execution time since the start of execution.

## Context menu

This context menu is available:

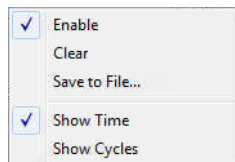

These commands are available:

### Enable

Enables the logging system. The system will log information also when the window is closed.

### Clear

Deletes the log information. Note that this will happen also when you reset the debugger.

### Save to File

Displays a standard file selection dialog box where you can select the destination file for the log information. The entries in the log file are separated by `TAB` and `LF` characters. An **X** in the **Approx** column indicates that the timestamp is an approximation.

### Show Time

Displays the **Time** column.

If the **Time** column is displayed by default in the C-SPY driver you are using, this menu command is not available.

### Show Cycles

Displays the **Cycles** column.

If the **Cycles** column is not supported in the C-SPY driver you are using, this menu command is not available.

## Sampled Graphs window

The **Sampled Graphs** window is available from the C-SPY driver menu.

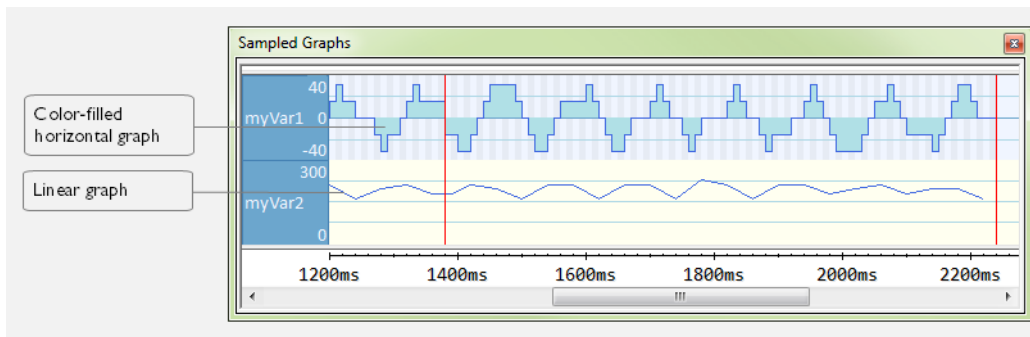

Use this window to display graphs for up to four different variables, and where:

- The graph displays how the value of the variable changes over time. The area on the left displays the limits, or range, of the Y-axis for the variable. You can use the context menu to change these limits. The graph is a graphical representation of the information in the **Data Sample** window, see *Data Sample window*, page 216.
- The graph can be displayed as levels, where a horizontal line—optionally color-filled—shows the value until the next sample. Alternatively, the graph can be linear, where a line connects consecutive samples.
- A red vertical line indicates the time of application execution stops.

At the bottom of the window, there is a shared time axis that uses seconds as the time unit.

To navigate in the graph, use any of these alternatives:

- Right-click and choose **Zoom In** or **Zoom Out** from the context menu. Alternatively, use the + and – keys to zoom.
- Right-click in the graph and choose **Navigate** and the appropriate command to move backward and forward on the graph. Alternatively, use any of the shortcut keys: arrow keys, Home, End, and Ctrl+End.
- Double-click on a sample to highlight the corresponding source code in the editor window and in the **Disassembly** window.
- Click on the graph and drag to select a time interval. Press Enter or right-click and choose **Zoom>Zoom to Selection** from the context menu. The selection zooms in.



Hover with the mouse pointer in the graph to get detailed tooltip information for that location.

See also *Getting started using data sampling*, page 197.



The graphs require hardware breakpoints. To preserve the required hardware breakpoints, use the option **Use only emulated breakpoints**, see *Breakpoints*, page 398.

## Requirements

A device that supports the trace buffer.

## Context menu

This context menu is available:

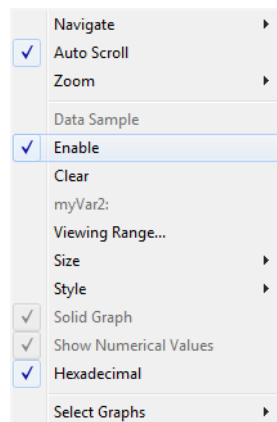

These commands are available:

### Navigate

Commands for navigating in the graphs. Choose between:

**Next** moves the selection to the next relevant point in the graph. Shortcut key: right arrow.

**Previous** moves the selection to the previous relevant point in the graph. Shortcut key: left arrow.

**First** moves the selection to the first data entry in the graph. Shortcut key: Home.

**Last** moves the selection to the last data entry in the graph. Shortcut key: End.

**End** moves the selection to the last data in any displayed graph, in other words the end of the time axis. Shortcut key: Ctrl+End.

**Auto Scroll**

Toggles automatic scrolling on or off. When on, the most recently collected data is automatically displayed when you choose **Navigate>End**.

**Zoom**

Commands for zooming the window, in other words, changing the time scale. Choose between:

**Zoom to Selection** makes the current selection fit the window. Shortcut key: Return.

**Zoom In** zooms in on the time scale. Shortcut key: +.

**Zoom Out** zooms out on the time scale. Shortcut key: -.

**1us, 10us, 100us** makes an interval of 1 microsecond, 10 microseconds, or 100 microseconds, respectively, fit the window.

**1ms, 10ms, 100ms** makes an interval of 1 millisecond, 10 milliseconds, or 100 milliseconds, respectively, fit the window.

**1s, 10s, 100s** makes an interval of 1 second, 10 seconds, or 100 seconds, respectively, fit the window.

**1k s, 10k s, 100k s** makes an interval of 1,000 seconds, 10,000 seconds, or 100,000 seconds, respectively, fit the window.

**1M s, 10M s,** makes an interval of 1,000,000 seconds or 10,000,000 seconds, respectively, fit the window.

**Data Sample**

A menu item that shows that the Data Sample-specific commands below are available.

**Open Setup window (Data Sample Graph)**

Opens the **Data Sample Setup** window.

**Enable**

Toggles the display of the graph on or off. If you disable a graph, that graph will be indicated as **OFF** in the window. If no data has been collected for a graph, **no data** will appear instead of the graph.

**Clear**

Clears the sampled data.

### ***Variable***

The name of the variable for which the Data Sample-specific commands below apply. This menu item is context-sensitive, which means it reflects the Data Sample graph you selected in the **Sampled Graphs** window (one of up to four).

### **Viewing Range**

Displays a dialog box, see *Viewing Range dialog box*, page 218.

### **Size**

Controls the vertical size of the graph; choose between **Small**, **Medium**, and **Large**.

### **Style**

Choose how to display the graph. Choose between:

**Levels**, where a horizontal line—optionally color-filled—shows the value until the next sample.

**Linear**, where a line connects consecutive samples.

### **Solid Graph**

Displays the graph as a color-filled solid graph instead of as a thin line. This is only possible if the graph is displayed as Levels.

### **Hexadecimal**

Toggles between displaying the selected value in decimal or hexadecimal format. Note that this setting also affects the log window.

### **Show Numerical Value**

Shows the numerical value of the variable, in addition to the graph.

### **Select Graphs**

Selects which graphs to display in the **Sampled Graphs** window.

## Data Sample Setup window

The **Data Sample Setup** window is available from the C-SPY driver menu.

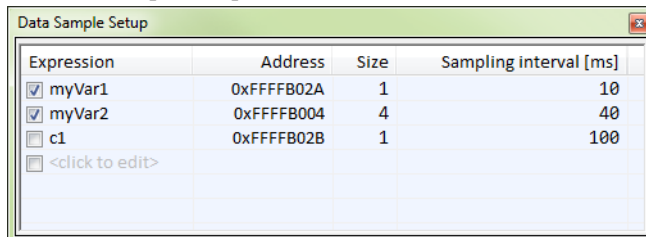

Use this window to specify up to four variables to sample data for. You can view the sampled data for the variables either in the **Data Sample** window or as graphs in the **Sampled Graphs** window.

See also *Getting started using data sampling*, page 197.

### Requirements

A device that supports the trace buffer.

### Display area

This area contains these columns:

#### Expression

Type the name of the variable which must be an integral type with a maximum size of 32 bits. Click the check box to enable or disable data sampling for the variable.

Alternatively, drag an expression from the editor window and drop it in the display area.

Variables in the expressions must be statically located, for example global variables.

#### Address

The actual memory address that is accessed. The column cells cannot be edited.

#### Size

The size of the variable, either 1, 2, or 4 bytes. The column cells cannot be edited.

#### Sampling interval [ms]

Type the number of milliseconds to pass between the samples. The shortest allowed interval is 10 ms and the interval you specify must be a multiple of that.

Note that the sampling time you specify is just the interval (according to the Microsoft Windows calculations) for how often C-SPY checks with the C-SPY driver (which in turn must check with the MCU for a value). If this takes longer than the sampling interval you have specified, the next sampling will be omitted. If this occurs, you might want to consider increasing the sampling time.

### Context menu

This context menu is available:

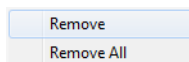

These commands are available:

#### Remove

Removes the selected variable.

#### Remove All

Removes all variables.

## Data Sample window

The **Data Sample** window is available from the C-SPY driver menu.

The Data Sample window displays a table with the following data:

Sampling Time	myVar1	myVar2
1160 ms	R 0x00	R 0x000000E8
1170 ms	R 0x10	
1170 ms	<i>Stop</i>	
1180 ms	R 0x10	R 0x000000D8
1190 ms	R 0x20	
1200 ms	R 0x10	
1210 ms	R 0x10	R 0x000000B8
1220 ms	R 0x00	

Use this window to view the result of the data sampling for the variables you have selected in the **Data Sample Setup** window.

Choose **Enable** from the context menu to enable data sampling.

See also *Getting started using data sampling*, page 197.

### Requirements

A device that supports the trace buffer.



## Display area

This area contains these columns:

### Sampling Time

The time when the data sample was collected. Time starts at zero after a reset. Every time the execution stops, a red `STOP` indicates when the stop occurred.

### *The selected expression*

The column headers display the names of the variables that you selected in the **Data Sample Setup** window. The column cells display the sampling values for the variable.

\* You can double-click a row in the display area. If you have enabled the data sample graph in the **Sampled Graphs** window, the selection line will be moved to reflect the time of the row you double-clicked.

## Context menu

This context menu is available:

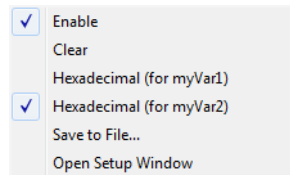

These commands are available:

### **Enable**

Enables data sampling.

### **Clear**

Clears the sampled data.

### **Hexadecimal**

Toggles between displaying the selected value in decimal or hexadecimal format. Note that this setting also affects the log window.

### **Save to File**

Displays a standard file selection dialog box where you can select the destination file for the log information. The entries in the log file are separated by `TAB` and `LF` characters. An **X** in the **Approx** column indicates that the timestamp is an approximation.

### **Open setup window**

Opens the **Data Sample Setup** window.

## Viewing Range dialog box

The **Viewing Range** dialog box is available from the context menu that appears when you right-click in any graph in the **Timeline** window that uses the linear, levels or columns style.

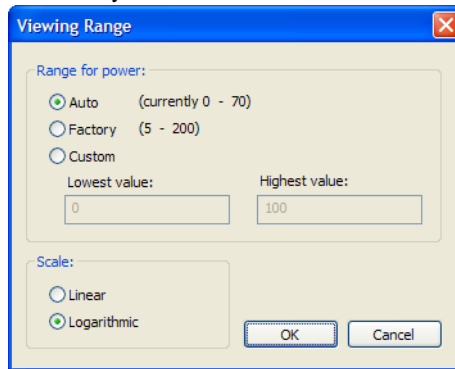

Use this dialog box to specify the value range, that is, the range for the Y-axis for the graph.

### Requirements

The C-SPY FET Debugger driver.

### Range for ...

Selects the viewing range for the displayed values:

#### Auto

Uses the range according to the range of the values that are actually collected, continuously keeping track of minimum or maximum values. The currently computed range, if any, is displayed in parentheses. The range is rounded to reasonably *even* limits.

#### Factory

For the Power Log graph: Uses the range according to the properties of the measuring hardware (only if supported by the product edition you are using).

For the other graphs: Uses the range according to the value range of the variable, for example 0–65535 for an unsigned 16-bit integer.

#### Custom

Use the text boxes to specify an explicit range.

**Scale**

Selects the scale type of the Y-axis:

- **Linear**
- **Logarithmic.**



# Profiling

- Introduction to the profiler
- Using the profiler
- Reference information on the profiler

---

## Introduction to the profiler

These topics are covered:

- Reasons for using the profiler
- Briefly about the profiler
- Requirements for using the profiler

### REASONS FOR USING THE PROFILER

*Function profiling* can help you find the functions in your source code where the most time is spent during execution. You should focus on those functions when optimizing your code. A simple method of optimizing a function is to compile it using speed optimization. Alternatively, you can move the data used by the function into more efficient memory. For detailed information about efficient memory usage, see the *IAR C/C++ Compiler User Guide for MSP430*.

Alternatively, you can use *filtered profiling*, which means that you can exclude, for example, individual functions from being profiled. To profile only a specific part of your code, you can select a *time interval*—using the **Timeline** window—for which C-SPY produces profiling information.

*Instruction profiling* can help you fine-tune your code on a very detailed level, especially for assembler source code. Instruction profiling can also help you to understand where your compiled C/C++ source code spends most of its time, and perhaps give insight into how to rewrite it for better performance.

### BRIEFLY ABOUT THE PROFILER

*Function profiling* information is displayed in the **Function Profiler** window, that is, timing information for the functions in an application. Profiling must be turned on explicitly using a button on the window's toolbar, and will stay enabled until it is turned off.

*Instruction profiling* information is displayed in the **Disassembly** window, that is, the number of times each instruction has been executed.

### Profiling sources

The profiler can use different mechanisms, or *sources*, to collect profiling information. Depending on the available trace source features, one or more of the sources can be used for profiling:

- Trace (calls)

The full instruction trace is analyzed to determine all function calls and returns. When the collected instruction sequence is incomplete or discontinuous, the profiling information is less accurate.

- Trace (flat)

Each instruction in the full instruction trace or each PC Sample is assigned to a corresponding function or code fragment, without regard to function calls or returns. This is most useful when the application does not exhibit normal call/return sequences, such as when you are using an RTOS, or when you are profiling code which does not have full debug information.

### Power sampling

Some debug probes support sampling of the power consumption of the development board. Each sample is associated with a PC sample and represents the power consumption (actually, the electrical current) for a small time interval preceding the time of the sample. When the profiler is set to use *Power Sampling*, additional columns are displayed in the **Profiler** window. Each power sample is associated with a function or code fragment, just as with regular PC Sampling. Note that this does not imply that all the energy corresponding to a sample can be attributed to that function or code fragment. The time scales of power samples and instruction execution are vastly different; during one power measurement, the CPU has typically executed many thousands of instructions. Power Sampling is a statistics tool.

## REQUIREMENTS FOR USING THE PROFILER

The C-SPY simulator supports the profiler; there are no specific requirements.

The function profiler is available in the hardware debugger system if your device and debug probe support it. The instruction profiler is not available in the hardware debugger system.

This table lists the C-SPY driver profiling support:

C-SPY driver	Trace (calls)	Trace (flat)	Power
C-SPY simulator	X	X	--
C-SPY FET Debugger driver	--	--	X

Table 9: C-SPY driver profiling support

## Using the profiler

These tasks are covered:

- Getting started using the profiler on function level
- Analyzing the profiling data
- Getting started using the profiler on instruction level



### GETTING STARTED USING THE PROFILER ON FUNCTION LEVEL

**To display function profiling information in the Function Profiler window:**

- 1 Build your application using these options:

Category	Setting
C/C++ Compiler	Output>Generate debug information
Linker	Output>Format>Debug information for C-SPY

Table 10: Project options for enabling the profiler

- 2 To set up the profiler for function profiling, choose **Options>Debugger>FET Debugger>Setup** and select **Enable ULP/LPMx.5 debug**.
- 3  When you have built your application and started C-SPY, choose **C-SPY driver>Function Profiler** to open the **Function Profiler** window, and click the **Enable** button to turn on the profiler. Alternatively, choose **Enable** from the context menu that is available when you right-click in the **Function Profiler** window.
- 4 Start executing your application to collect the profiling information.
- 5 Profiling information is displayed in the **Function Profiler** window. To sort, click on the relevant column header.
- 6  When you start a new sampling, you can click the **Clear** button—alternatively, use the context menu—to clear the data.

## ANALYZING THE PROFILING DATA

Here follow some examples of how to analyze the data.

The first figure shows the result of profiling using **Source: Trace (calls)**. The profiler follows the program flow and detects function entries and exits.

- For the **InitFib** function, **Flat Time** 231 is the time spent inside the function itself.
- For the **InitFib** function, **Acc Time** 487 is the time spent inside the function itself, including all functions **InitFib** calls.
- For the **InitFib/GetFib** function, **Acc Time** 256 is the time spent inside **GetFib** (but only when called from **InitFib**), including any functions **GetFib** calls.
- Further down in the data, you can find the **GetFib** function separately and see all of its subfunctions (in this case none).

Function	Calls	Flat Time	Flat Time (%)	Acc. Time	Acc. Time (%)
main	1	165	3.58	4356	94.39
DoForegroundProcess	10			3704	
InitFib	1			487	
PutFib	10	3174	68.78	3174	68.78
NextCounter	10	100	2.17	100	2.17
InitFib	1	231	5.01	487	10.55
GetFib	16			256	
GetFib	26	416	9.01	416	9.01
DoForegroundProcess	10	270	5.85	3704	80.26
GetFib	10			160	
NextCounter	10				
PutFib	10				
<Other>	0	25			98.85
main	1				

The second figure shows the result of profiling using **Source: Trace (flat)**. In this case, the profiler does not follow the program flow, instead the profiler only detects whether the PC address is within the function scope. For incomplete trace data, the data might contain minor errors.



For the **InitFib** function, **Flat Time** 231 is the time (number of hits) spent inside the function itself.

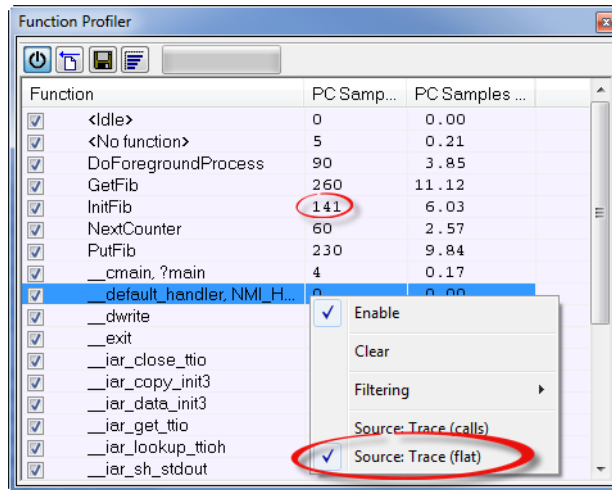

To secure valid data when using a debug probe, make sure to use the maximum trace buffer size and set a breakpoint in your code to stop the execution before the buffer is full.

## GETTING STARTED USING THE PROFILER ON INSTRUCTION LEVEL

**To display instruction profiling information in the Disassembly window:**

- 1 To set up the profiler for function profiling, choose **Options>Debugger>FET Debugger>Setup** and select **Enable ULP/LPMx.5 debug**.
- 2 When you have built your application and started C-SPY, choose **View>Disassembly** to open the **Disassembly** window, and choose **Instruction Profiling>Enable** from the context menu that is available when you right-click in the left-hand margin of the **Disassembly** window.
- 3 Make sure that the **Show** command on the context menu is selected, to display the profiling information.
- 4 Start executing your application to collect the profiling information.
- 5 When the execution stops, for instance because the program exit is reached or a breakpoint is triggered, you can view instruction level profiling information in the left-hand margin of the window.

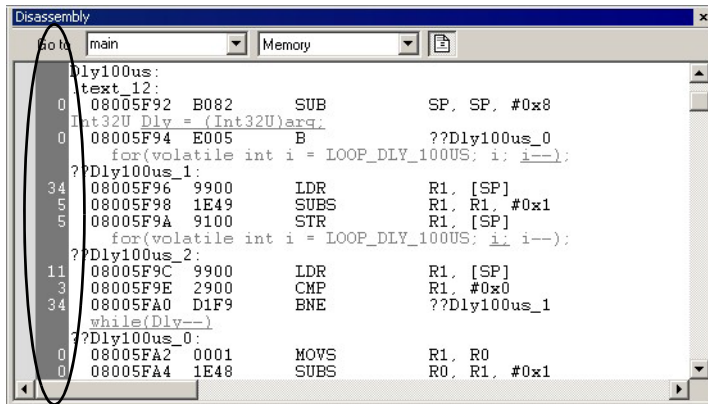

```

Disassembly
Go to: main Memory
Dly100us:
text_12:
0 08005F92 B082 SUB SP, SP, #0x8
Int32U_Dly = (Int32U)arg;
0 08005F94 E005 B ??Dly100us_0
for(volatile int i = LOOP_DLY_100US; i; i--):
??Dly100us_1:
34 08005F96 9900 LDR R1, [SP]
5 08005F98 1E49 SUBS R1, R1, #0x1
5 08005F9A 9100 STR R1, [SP]
for(volatile int i = LOOP_DLY_100US; i; i--):
??Dly100us_2:
11 08005F9C 9900 LDR R1, [SP]
3 08005F9E 2900 CMP R1, #0x0
34 08005FA0 D1F9 BNE ??Dly100us_1
while(Dly--)
??Dly100us_0:
0 08005FA2 0001 MOVS R1, R0
0 08005FA4 1E48 SUBS R0, R1, #0x1

```

For each instruction, the number of times it has been executed is displayed.

## Reference information on the profiler

Reference information about:

- *Function Profiler window*, page 226

See also:

- *Disassembly window*, page 67

## Function Profiler window

The **Function Profiler** window is available from the C-SPY driver menu.

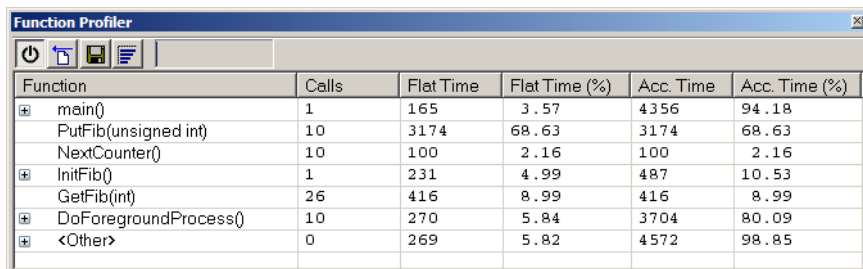

Function	Calls	Flat Time	Flat Time (%)	Acc. Time	Acc. Time (%)
main()	1	165	3.57	4356	94.18
PutFib(unsigned int)	10	3174	68.63	3174	68.63
NextCounter()	10	100	2.16	100	2.16
InitFib()	1	231	4.99	487	10.53
GetFib(int)	26	416	8.99	416	8.99
DoForegroundProcess()	10	270	5.84	3704	80.09
<Other>	0	269	5.82	4572	98.85

This figure reflects the C-SPY simulator driver.

This window displays function profiling information.

When Trace(flat) is selected, a checkbox appears on each line in the left-side margin of the window. Use these checkboxes to include or exclude lines from the profiling. Excluded lines are dimmed but not removed.

See also *Using the profiler*, page 223.

## Requirements

One of these alternatives:

- The C-SPY simulator
- The C-SPY FET Debugger driver and an MSP430 device with JSTATE register and an eZFET or MSP-FET debug probe.

Note that if you are using the C-SPY FET Debugger driver, the profiling sources Trace (flat) and Trace (calls) are not available.

## Toolbar

The toolbar contains:



### Enable/Disable

Enables or disables the profiler.



### Clear

Clears all profiling data.



### Save

Opens a standard **Save As** dialog box where you can save the contents of the window to a file, with tab-separated columns. Only non-expanded rows are included in the list file.



### Graphical view

Overlays the values in the percentage columns with a graphical bar.

### *Progress bar*

Displays a backlog of profiling data that is still being processed. If the rate of incoming data is higher than the rate of the profiler processing the data, a backlog is accumulated. The progress bar indicates that the profiler is still processing data, but also approximately how far the profiler has come in the process. Note that because the profiler consumes data at a certain rate and the target system supplies data at another rate, the amount of data remaining to be processed can both increase and decrease. The progress bar can grow and shrink accordingly.

## Display area

The content in the display area depends on which source that is used for the profiling information:

- For the Trace (calls) source, the display area contains one line for each function compiled with debug information enabled. When some profiling information has been collected, it is possible to expand rows of functions that have called other functions. The child items for a given function list all the functions that have been called by the parent function and the corresponding statistics.
- For the Trace (flat) source, the display area contains one line for each C function of your application, but also lines for sections of code from the runtime library or from other code without debug information, denoted only by the corresponding assembler labels. Each executed PC address from trace data is treated as a separate sample and is associated with the corresponding line in the Profiling window. Each line contains a count of those samples.

For information about which views that are supported in the C-SPY driver you are using, see *Requirements for using the profiler*, page 222.

More specifically, the display area provides information in these columns:

### **Function (All sources)**

The name of the profiled C function.

### **Calls (Trace (calls))**

The number of times the function has been called.

### **Flat time (Trace (calls))**

The time expressed in cycles spent inside the function.

### **Flat time (%) (Trace (calls))**

Flat time expressed as a percentage of the total time.

### **Acc. time (Trace (calls))**

The time expressed in cycles spent inside the function and everything called by the function.

### **Acc. time (%) (Trace (calls))**

Accumulated time expressed as a percentage of the total time.

### **PC Samples (Trace (flat))**

The number of PC samples associated with the function.

### **PC Samples (%) (Trace (flat))**

The number of PC samples associated with the function as a percentage of the total number of samples.

**Power Samples (Power Sampling)**

The number of power samples associated with that function.

**Energy (%) (Power Sampling)**

The accumulated value of all measurements associated with that function, expressed as a percentage of all measurements.

**Avg Current [mA] (Power Sampling)**

The average measured value for all samples associated with that function.

**Min Current [mA] (Power Sampling)**

The minimum measured value for all samples associated with that function.

**Max Current [mA] (Power Sampling)**

The maximum measured value for all samples associated with that function.

**Context menu**

This context menu is available:

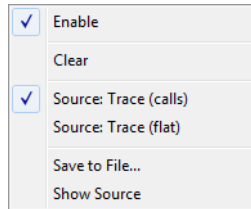

The contents of this menu depend on the C-SPY driver you are using.

These commands are available:

**Enable**

Enables the profiler. The system will collect information also when the window is closed.

**Clear**

Clears all profiling data.

**Filtering**

Selects which part of your code to profile. Choose between:

**Check All**—Excludes all lines from the profiling.

**Uncheck All**—Includes all lines in the profiling.

**Load**—Reads all excluded lines from a saved file.

**Save**—Saves all excluded lines to a file. Typically, this can be useful if you are a group of engineers and want to share sets of exclusions.

These commands are only available when using Trace (flat).

**Source\***

Selects which source to be used for the profiling information. See also *Profiling sources*, page 222. Choose between:

**Trace (calls)**—the instruction count for instruction profiling is only as complete as the collected trace data.

**Trace (flat)**—the instruction count for instruction profiling is only as complete as the collected trace data.

**Power Sampling**

Toggles power sampling information on or off.

**Save to File**

Saves all profiling data to a file.

**Show Source**

Opens the editor window (if not already opened) and highlights the selected source line.

\* The available sources depend on the C-SPY driver you are using.

# Code coverage

- Introduction to code coverage
- Reference information on code coverage.

---

## Introduction to code coverage

These topics are covered:

- Reasons for using code coverage
- Briefly about code coverage
- Requirements and restrictions for using code coverage.

### REASONS FOR USING CODE COVERAGE

The code coverage functionality is useful when you design your test procedure to verify whether all parts of the code have been executed. It also helps you identify parts of your code that are not reachable.

### BRIEFLY ABOUT CODE COVERAGE

The **Code Coverage** window reports the status of the current code coverage analysis for C code. For every program, module, and function, the analysis shows the percentage of code that has been executed since code coverage was turned on up to the point where the application has stopped. In addition, all statements that have not been executed are listed. The analysis will continue until turned off.

**Note:** Assembler code is not covered by the code coverage analysis. To view assembler code, use the **Disassembly** window.

### REQUIREMENTS AND RESTRICTIONS FOR USING CODE COVERAGE

Code coverage is supported by the C-SPY Simulator and there are no specific requirements or restrictions.

---

## Reference information on code coverage

Reference information about:

- *Code Coverage window*, page 232.

See also *Single stepping*, page 60.

## Code Coverage window

The **Code Coverage** window is available from the **View** menu.

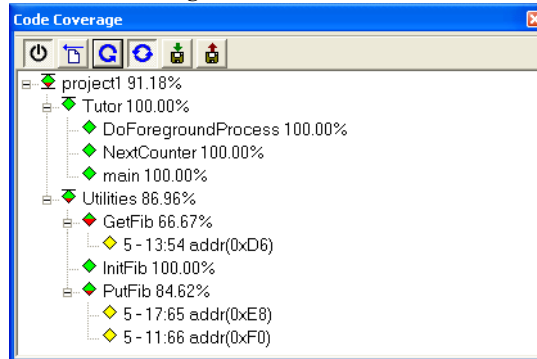

This window reports the status of the current code coverage analysis. For every program, module, and function, the analysis shows the percentage of code that has been executed since code coverage was turned on up to the point where the application has stopped. In addition, all statements that have not been executed are listed. The analysis will continue until turned off.

An asterisk (\*) in the title bar indicates that C-SPY has continued to execute, and that the **Code Coverage** window must be refreshed because the displayed information is no longer up to date. To update the information, use the **Refresh** button.

### To get started using code coverage:

- 1 Before using the code coverage functionality you must build your application using these options:

Category	Setting
C/C++ Compiler	Output>Generate debug information
Linker	Format>Debug information for C-SPY
Debugger	Plugins>Code Coverage

Table 11: Project options for enabling code coverage

- 2 After you have built your application and started C-SPY, choose **View>Code Coverage** to open the **Code Coverage** window.
- 3 Click the **Activate** button, alternatively choose **Activate** from the context menu, to switch on code coverage.







- 4 Start the execution. When the execution stops, for instance because the program exit is reached or a breakpoint is triggered, click the **Refresh** button to view the code coverage information.

### Requirements

The C-SPY simulator.

### Display area

The code coverage information is displayed in a tree structure, showing the program, module, function, and statement levels. The window displays only source code that was compiled with debug information. Thus, startup code, exit code, and library code is not displayed in the window. Furthermore, coverage information for statements in inlined functions is not displayed. Only the statement containing the inlined function call is marked as executed. The plus sign and minus sign icons allow you to expand and collapse the structure.

These icons give you an overview of the current status on all levels:

Red diamond	Signifies that 0% of the modules or functions has been executed.
Green diamond	Signifies that 100% of the modules or functions has been executed.
Red and green diamond	Signifies that some of the modules or functions have been executed.
Yellow diamond	Signifies a statement that has not been executed.

The percentage displayed at the end of every program, module, and function line shows the amount of statements that has been covered so far, that is, the number of executed statements divided with the total number of statements.

For statements that have not been executed (yellow diamond), the information displayed is the column number range and the row number of the statement in the source window, followed by the address of the step point:

```
<column_start>-<column_end>: row address.
```

A statement is considered to be executed when one of its instructions has been executed. When a statement has been executed, it is removed from the window and the percentage is increased correspondingly.

Double-clicking a statement or a function in the **Code Coverage** window displays that statement or function as the current position in the editor window, which becomes the

active window. Double-clicking a module on the program level expands or collapses the tree structure.

### Context menu

This context menu is available:

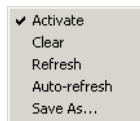

These commands are available:



#### Activate

Switches code coverage on and off during execution.



#### Clear

Clears the code coverage information. All step points are marked as not executed.



#### Refresh

Updates the code coverage information and refreshes the window. All step points that have been executed since the last refresh are removed from the tree.



#### Auto-refresh

Toggles the automatic reload of code coverage information on and off. When turned on, the code coverage information is reloaded automatically when C-SPY stops at a breakpoint, at a step point, and at program exit.

#### Save As

Saves the current code coverage result in a text file.



#### Save session

Saves your code coverage session data to a \*.dat file. This is useful if you for some reason must abort your debug session, but want to continue the session later on. This command is available on the toolbar. This command might not be supported by the C-SPY driver you are using.



#### Restore session

Restores previously saved code coverage session data. This is useful if you for some reason must abort your debug session, but want to continue the session later on. This command is available on the toolbar. This command might not be supported by the C-SPY driver you are using.

# Power debugging

- Introduction to power debugging
- Optimizing your source code for power consumption
- Debugging in the power domain
- Reference information on power debugging.

---

## Introduction to power debugging

These topics are covered:

- Reasons for using power debugging
- Briefly about power debugging
- Requirements and restrictions for power debugging.

### REASONS FOR USING POWER DEBUGGING

Long battery lifetime is a very important factor for many embedded systems in almost any market segment: medical, consumer electronics, home automation, etc. The power consumption in these systems does not only depend on the hardware design, but also on how the hardware is used. The system software controls how it is used.

For examples of when power debugging can be useful, see *Optimizing your source code for power consumption*, page 237.

### BRIEFLY ABOUT POWER DEBUGGING

Power debugging is based on the ability to sample the power consumption—more precisely, the power being consumed by the CPU and the peripheral units—and correlate each sample with the application's instruction sequence and hence with the source code and various events in the program execution.

Traditionally, the main software design goal has been to use as little memory as possible. However, by correlating your application's power consumption with its source code you can get insight into how the software affects the power consumption, and thus how it can be minimized.

Power debugging in C-SPY supports the EnergyTrace™ Technology provided by Texas Instruments.

## Measuring power consumption

Debug probes with EnergyTrace™ Technology support measure the power supplied to a target microcontroller. A software-controlled DC–DC converter generates the target power supply. The time density of the DC–DC converter charge pulses equals the power consumption of the target microcontroller. A built-in on-the-fly calibration circuit defines the energy equivalent of a single DC–DC charge pulse.

For more information about the debug probes, see the *MSP430 Hardware Tools User's Guide* on the Texas Instruments website.

## Power debugging using C-SPY

C-SPY provides an interface for configuring your power debugging and a set of windows for viewing the power values:

- The **Power Setup** window is where you can specify a threshold and an action to be executed when the threshold is reached. This means that you can enable or disable the power measurement or you can stop the application's execution and determine the cause of unexpected power values.
- The **Power Log** window displays all logged power values. This window can be used for finding peaks in the power logging and because the values are correlated with the executed code, you can double-click on a value in the **Power Log** window to get the corresponding code. The precision depends on the frequency of the samples, but there is a good chance that you find the source code sequence that caused the peak.
- The Power graph in the **Timeline** window displays power values on a time scale. This provides a convenient way of viewing the power consumption in relation to the other information displayed in the window. The **Timeline** window is correlated to both the **Power Log** window, the source code window, and the **Disassembly** window, which means you are just a double-click away from the source code that corresponds to the values you see on the timeline.
- The **State Log** window logs activity—state changes—for peripheral units and clocks, as well as for CPU modes. The **State Log Summary** window displays a summary of the logged activity. The State Log graphs display a graphical view of the activity. The information is useful for tracing the activity on the target system.
- The **Function Profiler** window combines the function profiling with the power logging to display the power consumption per function—power profiling. You will get a list of values per function and also the average values together with max and min values. Thus, you will find the regions in the application that you should focus when optimizing for power consumption.

## REQUIREMENTS AND RESTRICTIONS FOR POWER DEBUGGING

Power debugging in C-SPY support two capture modes, with different capabilities:

- EnergyTrace™, which can output timestamps, voltage, current, and energy information. This mode is available for all MSP430 devices with both MSP-FET (black box) and eZ-FET.
- EnergyTrace++™, which can output timestamps, state log information for peripheral units, clocks, and CPU modes (64-bit JSTATE register content), voltage, current, and energy information. This mode is available for all MSP430 devices with the JSTATE register, currently the MSP430FR59xx device family, together with both the MSP-FET (black box) and the eZ-FET debugger probe. The respective device-specific .menu file includes an <energytrace>1</energytrace> tag.

To use the features in C-SPY for power debugging, you also need:

- The C-SPY FET Debugger driver.

**Note:** The MSP-FET430UIF (gray box) and the eZ430 debug probes do not support power debugging.

---

## Optimizing your source code for power consumption

This section gives some examples where power debugging can be useful and thus hopefully help you identify source code constructions that can be optimized for low power consumption.

These topics are covered:

- Waiting for device status
- Software delays
- DMA versus polled I/O
- Low-power mode diagnostics
- CPU frequency
- Detecting mistakenly unattended peripherals
- Peripheral units in an event-driven system
- Finding conflicting hardware setups
- Analog interference

## WAITING FOR DEVICE STATUS

One common construction that could cause unnecessary power consumption is to use a poll loop for waiting for a status change of, for example a peripheral device. Constructions like this example execute without interruption until the status value changes into the expected state.

```
while (USBD_GetState() < USBD_STATE_CONFIGURED);
while ((BASE_PMC->PMC_SR & MC_MCKRDY) != PMC_MCKRDY);
```

To minimize power consumption, rewrite polling of a device status change to use interrupts if possible, or a timer interrupt so that the CPU can sleep between the polls.

## SOFTWARE DELAYS

A software delay might be implemented as a `for` or `while` loop like for example:

```
i = 10000; /* A software delay */
do i--;
while (i != 0);
```

Such software delays will keep the CPU busy with executing instructions performing nothing except to make the time go by. Time delays are much better implemented using a hardware timer. The timer interrupt is set up and after that, the CPU goes down into a low power mode until it is awakened by the interrupt.

## DMA VERSUS POLLED I/O

DMA has traditionally been used for increasing transfer speed. For MCUs there are plenty of DMA techniques to increase flexibility, speed, and to lower power consumption. Sometimes, CPUs can even be put into sleep mode during the DMA transfer. Power debugging lets you experiment and see directly in the debugger what effects these DMA techniques will have on power consumption compared to a traditional CPU-driven polled solution.

## LOW-POWER MODE DIAGNOSTICS

Many embedded applications spend most of their time waiting for something to happen: receiving data on a serial port, watching an I/O pin change state, or waiting for a time delay to expire. If the processor is still running at full speed when it is idle, battery life is consumed while very little is being accomplished. So in many applications, the microcontroller is only active during a very small amount of the total time, and by placing it in a low-power mode during the idle time, the battery life can be extended considerably.

A good approach is to have a task-oriented design. In a task-oriented design, a task can be defined with the lowest priority, and it will only execute when there is no other task that needs to be executed. This idle task is the perfect place to implement power

management. In practice, every time the idle task is activated, it sets the microcontroller into a low-power mode. All MSP430 devices have a number of different low-power modes, in which different parts of the microcontroller can be turned off when they are not needed. The oscillator can for example either be turned off or switched to a lower frequency. In addition, individual peripheral units, timers, and the CPU can be stopped. The different low-power modes have different power consumption based on which peripherals are left turned on. A power debugging tool can be very useful when experimenting with different low-level modes.

You can use the Function profiler in C-SPY to compare power measurements for the task or function that sets the system in a low-power mode when different low-power modes are used. Both the mean value and the percentage of the total power consumption can be useful in the comparison.

## CPU FREQUENCY

Power consumption in a CMOS MCU is theoretically given by the formula:

$$P = f * U^2 * k$$

where  $f$  is the clock frequency,  $U$  is the supply voltage, and  $k$  is a constant.

Power debugging lets you verify the power consumption as a factor of the clock frequency. A system that spends very little time in sleep mode at 10 MHz is expected to spend 50% of the time in sleep mode when running at 20 MHz. You can use the power data collected in C-SPY to verify the expected behavior, and if there is a non-linear dependency on the clock frequency, make sure to choose the operating frequency that gives the lowest power consumption.

## DETECTING MISTAKENLY UNATTENDED PERIPHERALS

Peripheral units can consume much power even when they are not actively in use. If you are designing for low power, it is important that you disable the peripheral units and not just leave them unattended when they are not in use. But for different reasons, a peripheral unit can be left with its power supply on; it can be a careful and correct design decision, or it can be an inadequate design or just a mistake. If not the first case, then more power than expected will be consumed by your application. This will be easily revealed by the Power graph in the **Timeline** window. Double-clicking in the **Timeline** window where the power consumption is unexpectedly high will take you to the corresponding source code and disassembly code. In many cases, it is enough to disable the peripheral unit when it is inactive, for example by turning off its clock which in most cases will shut down its power consumption completely.

However, there are some cases where clock gating will not be enough. Analog peripherals like converters or comparators can consume a substantial amount of power

even when the clock is turned off. The **Timeline** window will reveal that turning off the clock was not enough and that you need to turn off the peripheral completely.

### PERIPHERAL UNITS IN AN EVENT-DRIVEN SYSTEM

Consider a system where one task uses an analog comparator while executing, but the task is suspended by a higher-priority task. Ideally, the comparator should be turned off when the task is suspended and then turned on again once the task is resumed. This would minimize the power being consumed during the execution of the high-priority task.

This is a schematic diagram of the power consumption of an assumed event-driven system where the system at the point of time  $t_0$  is in an inactive mode and the current is  $I_0$ :



At  $t_1$ , the system is activated whereby the current rises to  $I_1$  which is the system's power consumption in active mode when at least one peripheral device turned on, causing the current to rise to  $I_1$ . At  $t_2$ , the execution becomes suspended by an interrupt which is handled with high priority. Peripheral devices that were already active are not turned off, although the task with higher priority is not using them. Instead, more peripheral devices are activated by the new task, resulting in an increased current  $I_2$  between  $t_2$  and  $t_3$  where control is handed back to the task with lower priority.

The functionality of the system could be excellent and it can be optimized in terms of speed and code size. But also in the power domain, more optimizations can be made. The shadowed area represents the energy that could have been saved if the peripheral devices that are not used between  $t_2$  and  $t_3$  had been turned off, or if the priorities of the two tasks had been changed.



If you use the **Timeline** window, you can make a closer examination and identify that unused peripheral devices were activated and consumed power for a longer period than necessary. Naturally, you must consider whether it is worth it to spend extra clock cycles to turn peripheral devices on and off in a situation like in the example.

## FINDING CONFLICTING HARDWARE SETUPS

To avoid floating inputs, it is a common design practice to connect unused MCU I/O pins to ground. If your source code by mistake configures one of the grounded I/O pins as a logical 1 output, a high current might be drained on that pin. This high unexpected current is easily observed by reading the current value from the Power graph in the **Timeline** window. It is also possible to find the corresponding erratic initialization code by looking at the Power graph at application startup.

A similar situation arises if an I/O pin is designed to be an input and is driven by an external circuit, but your code incorrectly configures the input pin as output.

## ANALOG INTERFERENCE

When mixing analog and digital circuits on the same board, the board layout and routing can affect the analog noise levels. To ensure accurate sampling of low-level analog signals, it is important to keep noise levels low. Obtaining a well-mixed signal design requires careful hardware considerations. Your software design can also affect the quality of the analog measurements.

Performing a lot of I/O activity at the same time as sampling analog signals causes many digital lines to toggle state at the same time, which might introduce extra noise into the AD converter.

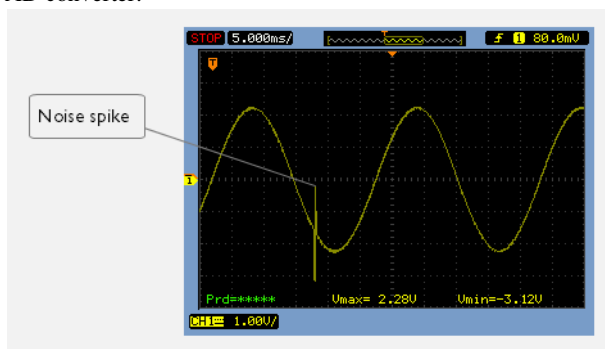

Power debugging will help you investigate interference from digital and power supply lines into the analog parts. Power spikes in the vicinity of AD conversions could be the source of noise and should be investigated. All data presented in the **Timeline** window

is correlated to the executed code. Simply double-clicking on a suspicious power value will bring up the corresponding C source code.

---

## Debugging in the power domain

These tasks are covered:

- Displaying a power profile and analyzing the result
- Displaying the power profile on a device without EnergyTrace++
- Detecting unexpected power usage during application execution
- Measuring low power currents
- Changing the graph resolution.

See also:

- *Power graph in the Timeline window*, page 251

### DISPLAYING A POWER PROFILE AND ANALYZING THE RESULT

**To view the power profile on a device with EnergyTrace++:**

- 1** Before you start the debug session, choose **Project>Options>Debugger>FET Debugger>Setup>Enable ULP/LPMx.5 debug**.
- 2** Start the debugger.
- 3** Choose **C-SPY driver>Power Log Setup**. In the **ID** column, make sure to select the alternatives for which you want to enable power logging: **Current**, **Voltage**, or **Energy**.
- 4** Choose **C-SPY driver>Timeline** to open the **Timeline** window.
- 5** Right-click in the graph area and choose **Enable** from the context menu to enable the power graph you want to view. Repeat this for each graph you want to view.
- 6** Choose **C-SPY driver>Power Log** to open the **Power Log** window.
- 7** Optionally, if you want to correlate power values to the status of peripheral units, clocks, and CPU modes, right-click in the State Log graph area, and choose **Enable** from the context menu.
- 8** Optionally, before you start executing your application you can configure the viewing range of the Y-axis for the power graphs. See *Viewing Range dialog box*, page 218.

- 9 Click **Go** on the toolbar to start executing your application. In the **Power Log** window, all power values are displayed. In the **Timeline** window, you will see a graphical representation of the power values, and a graphical representation of the logged activity—state changes—for peripheral units and clocks, as well as CPU modes if you enabled the State Log graph. For information about how to navigate on the graph, see *Power graph in the Timeline window*, page 251.

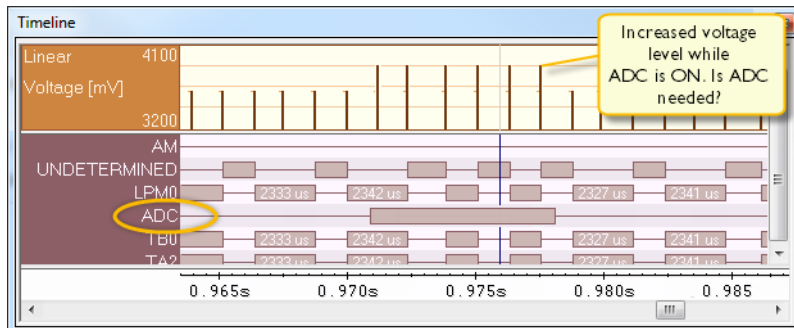

- 10 To analyze power consumption:

- Double-click on an interesting power value to highlight the corresponding source code in the editor window and in the **Disassembly** window. The corresponding log is highlighted in the **Power Log** window. For examples of when this can be useful, see *Optimizing your source code for power consumption*, page 237.
- You can identify peripheral units to disable if they are not used. You can detect this by analyzing the power graph in combination with the State Log Graph in the **Timeline** window. See also *Detecting mistakenly unattended peripherals*, page 239.

## DISPLAYING THE POWER PROFILE ON A DEVICE WITHOUT ENERGYTRACE++

### To view the power profile on a device without EnergyTrace++:

- 1 Start the debugger.
- 2 Choose **C-SPY driver>Power Log Setup**. In the **ID** column, make sure to select the alternatives for which you want to enable power logging: **Current**, **Voltage**, or **Energy**.
- 3 Choose **C-SPY driver>Timeline** to open the **Timeline** window.
- 4 Right-click in the graph area and choose **Enable** from the context menu to enable the power graph you want to view. Repeat this for each graph you want to view.
- 5 Choose **C-SPY driver>Power Log** to open the **Power Log** window.

- Click **Go** on the toolbar to start executing your application. In the **Power Log** window, all power values are displayed. In the **Timeline** window, you will see a graphical representation of the power values. For information about how to navigate on the graph, see *Power graph in the Timeline window*, page 251.

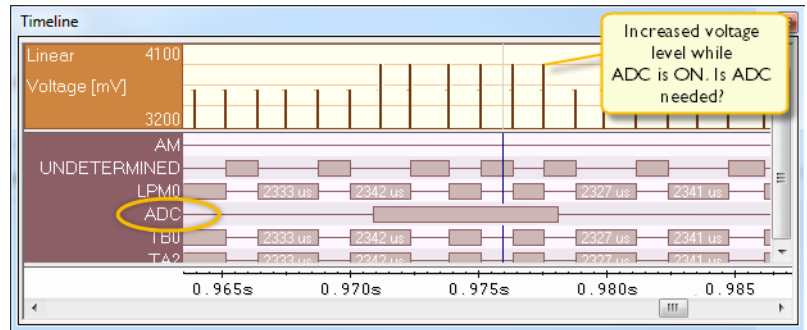

## DETECTING UNEXPECTED POWER USAGE DURING APPLICATION EXECUTION

To detect unexpected power consumption on a device with EnergyTrace++:

- Choose **C-SPY driver>Power Log Setup** to open the **Power Setup** window.
- In the **Power Setup** window, specify a threshold value and the appropriate action, for example **Log All and Halt CPU Above Threshold**.
- Choose **C-SPY driver>Power Log** to open the **Power Log** window. If you continuously want to save the power values to a file, choose **Choose Live Log File** from the context menu. In this case you also need to choose **Enable Live Logging to**.
- Start the execution.

When the power consumption passes the threshold value, the execution will stop and perform the action you specified.

If you saved your logged power values to a file, you can open that file in an external tool for further analysis.

## MEASURING LOW POWER CURRENTS

During the capture of the internal states or even when simply executing until a breakpoint stops the execution, the target microcontroller is constantly accessed via JTAG or Spy-Bi-Wire debug logic. These debug accesses consume energy that will be included in the numbers displayed in the **Power Log** window and graphs. To measure the power numbers of just the application, it is therefore recommended to use the

**Release JTAG on Go** option, which means that the debug logic of the target microcontroller is not accessed while measuring the power consumption.

#### To measure low power currents:

- 1 Before you start the debug session, choose **Project>Options>Debugger>FET Debugger>Setup>Enable ULP/LPMx.5 debug**.
- 2 Start the debugger.
- 3 Choose **C-SPY driver>Release JTAG on Go**.
- 4 Choose **C-SPY driver>Power Log Setup**. In the **ID** column, select the alternatives for which you want to enable power logging: **Current**, **Voltage**, or **Energy**.
- 5 To enable the graphs in the **Timeline** window, choose **Emulator>Timeline** to open the **Timeline** window. Right-click in the graph area for each graph that you have enabled power logging for and choose **Enable** from the context menu.
- 6 Start the execution.

Power logging is enabled and you can now see the graphs appear in the **Timeline** window.

## CHANGING THE GRAPH RESOLUTION

#### To change the resolution of a Power graph in the Timeline window:

- 1 In the **Timeline** window, select the Power graph, right-click and choose **Open Setup Window** to open the **Power Log Setup** window.
- 2 From the context menu in the **Power Log Setup** window, choose a suitable unit of measurement.
- 3 In the **Timeline** window, select the Power graph, right-click and choose **Viewing Range** from the context menu.
- 4 In the **Viewing Range** dialog box, select **Custom** and specify range values in the **Lowest value** and the **Highest value** text boxes. Click **OK**.
- 5 The graph is automatically updated accordingly.

---

## Reference information on power debugging

Reference information about:

- *Power Log Setup window*, page 246
- *Power graph in the Timeline window*, page 251.
- *Power Log window*, page 248.

- *Timeline window—State Log graph*, page 257.
- *State Log window*, page 252.
- *State Log Summary window*, page 254.

See also:

- *Trace window*, page 180
- *Viewing Range dialog box*, page 218
- *Function Profiler window*, page 226.

## Power Log Setup window

The Power Log Setup window is available from the C-SPY driver menu during a debug session.

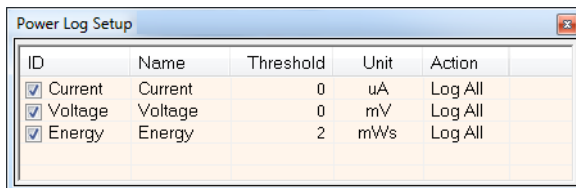

Use this window to configure the power measurement.

**Note:** To enable power logging, choose **Enable** from the context menu in the Power Log window or from the context menu in the power graph in the Timeline window.

### Requirements

An eZFET or MSP-FET debug probe.

### Display area

This area contains these columns:

#### ID

A unique string that identifies the measurement channel in the probe. Select the check box to activate the channel. If the check box is deselected, logs will not be generated for that channel.

#### Name

Specify a user-defined name.

#### Threshold

Specify a threshold value in the selected unit. The action you specify will be executed when the threshold value is reached.

**Unit**

Displays the selected unit for power. You can choose a unit from the context menu.

**Action**

Displays the selected action for the measurement channel. Choose between:

- **Log All**
- **Log Above Threshold**
- **Log Below Threshold**
- **Log All and Halt CPU Above Threshold**
- **Log All and Halt CPU Below Threshold**

**Context menu**

This context menu is available:

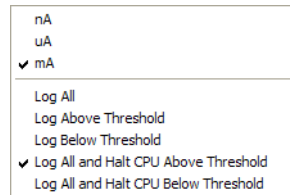

These commands are available:

**nA, uA, mA**

Selects the unit for the power display. These alternatives are available for channels that measure current.

**uV, mV, V**

Selects the unit for power display. These alternatives are available for channels that measure voltage.

**uWs, mWs, Ws**

Selects the unit for power display. These alternatives are available for channels that measure energy.

**Log All**

Logs all values.

**Log Above Threshold**

Logs all values above the threshold.

**Log Below Threshold**

Logs all values below the threshold.

**Log All and Halt CPU Above Threshold**

Logs all values. If a logged value exceeds the threshold, execution is stopped.

**Log All and Halt CPU Below Threshold**

Logs all values. If a logged value goes below the threshold, execution is stopped.

**Power Log window**

The Power Log window is available from the C-SPY driver menu during a debug session.

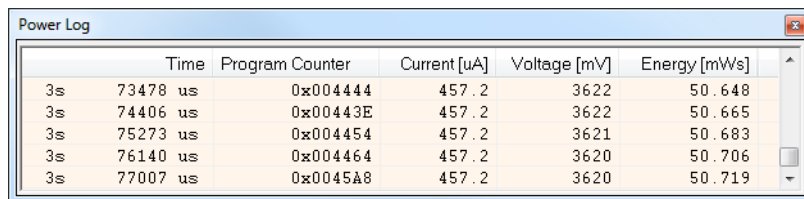

	Time	Program Counter	Current [uA]	Voltage [mV]	Energy [mWs]
3s	73478 us	0x004444	457.2	3622	50.648
3s	74406 us	0x00443E	457.2	3622	50.665
3s	75273 us	0x004454	457.2	3621	50.683
3s	76140 us	0x004464	457.2	3620	50.706
3s	77007 us	0x0045A8	457.2	3620	50.719

This window displays collected power values.

A row with only Time/Cycles and Program Counter displayed in grey denotes a logged power value for a channel that was active during the actual collection of data but currently is disabled in the Power Log Setup window.

**Note:** The number of logged power values is limited. When this limit is exceeded, the oldest entries in the buffer are erased.

**Requirements**

An eZFET or MSP-FET debug probe.

**Display area**

This area contains these columns:

**Time**

The time from the application reset until the event, based on time stamps.

This column is available when you have selected **Show Time** from the context menu.

**Program Counter**

Displays one of these:

An address, which is the content of the PC, that is, the address of an instruction close to where the power value was collected.

---, the target system failed to provide the debugger with any information.



**Overflow** in red, the communication channel failed to transmit all data from the target system.

Note that the **Program Counter** column is available only if your device supports it.

#### *Name* [unit]

The power measurement value expressed in the unit you specified in the **Power Setup** window.

### Context menu

This context menu is available:

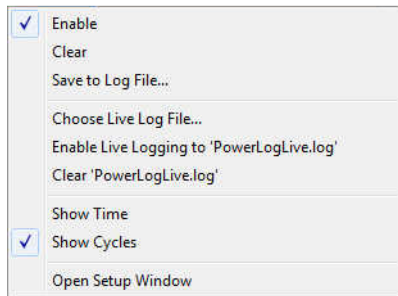

These commands are available:

#### **Enable**

Enables the logging system, which means that power values are saved internally within the IDE. The values are displayed in the **Power Log** window and in the Power graph in the **Timeline** window (if enabled). The system will log information also when the window is closed.

#### **Clear**

Deletes the log information. Note that this will also happen when you reset the debugger.

#### **Save to File**

Displays a standard file selection dialog box where you can select the destination file for the log information. The entries in the log file are separated by `TAB` and `LF` characters. An **X** in the **Approx** column indicates that the timestamp is an approximation.

### **Choose Live Log File**

Displays a standard file selection dialog box where you can choose a destination file for the logged power values. The power values are continuously saved to that file during execution. The content of the live log file is never automatically cleared, the logged values are simply added at the end of the file.

### **Enable Live Logging to**

Toggles live logging on or off. The logs are saved in the specified file.

### **Clear *log file***

Clears the content of the live log file.

### **Show Time**

Displays the **Time** column.

If the **Time** column is displayed by default in the C-SPY driver you are using, this menu command is not available.

### **Show Cycles**

Displays the **Cycles** column.

If the **Cycles** column is not supported in the C-SPY driver you are using, this menu command is not available.

### **Open Setup Window**

Opens the **Power Log Setup** window.

## **The format of the log file**

The log file has a tab-separated format. The entries in the log file are separated by `TAB` and line feed. The logged power values are displayed in these columns:

### **Time/Cycles**

The time from the application reset until the power value was logged.

### **Approx**

An **x** in the column indicates that the power value has an approximative value for time/cycle.

### **PC**

The value of the program counter close to the point where the power value was logged.

### **Name[unit]**

The corresponding value from the **Power Log** window, where *Name* and *unit* are according to your settings in the **Power Log Setup** window.

## Power graph in the Timeline window

The power graph in the Timeline window is available from the C-SPY driver menu during a debug session.

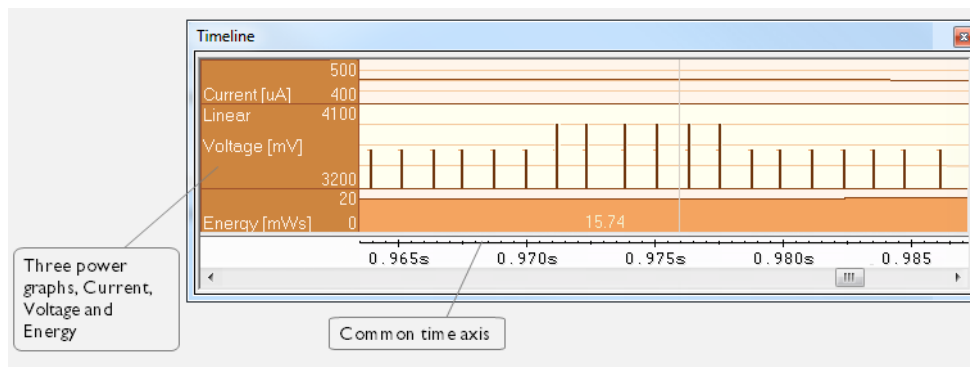

The power graph displays a graphical view of power measurement samples.

Depending on the abilities in hardware, the debug probe, and the C-SPY driver you are using, this window can display a Power Log graph that shows power measurement samples generated by the debug probe or associated hardware in relation to a common time axis.

For more information about the Timeline window, how to display a graph, and the other supported graphs, see *Reference information on application timeline*, page 197.

See also *Requirements and restrictions for power debugging*, page 237.

### Requirements

An eZFET or MSP-FET debug probe.

### Display area

Where:

- The label area at the left end of the graph displays the name of the measurement channel.
- The Voltage and the Current graphs show power measurement samples generated by the debug probe or associated hardware. The Energy graph shows accumulated energy since the last time the CPU was stopped.
- The graphs can be displayed as a thin line between consecutive logs, as a rectangle for every log (optionally color-filled), or as columns.
- The resolution of the graphs can be changed.

At the bottom of the window, there is a common time axis that uses seconds as the time unit.

## State Log window

The **State Log** window is available from the C-SPY driver menu.

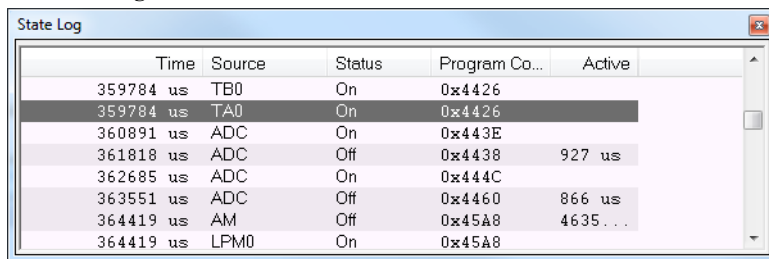

Time	Source	Status	Program Co...	Active
359784 us	TB0	On	0x4426	
359784 us	TA0	On	0x4426	
360891 us	ADC	On	0x443E	
361818 us	ADC	Off	0x4438	927 us
362685 us	ADC	On	0x444C	
363551 us	ADC	Off	0x4460	866 us
364419 us	AM	Off	0x45A8	4635...
364419 us	LPM0	On	0x45A8	

This window logs activity—state changes—for peripheral units and clocks, as well as for CPU modes.

The information is useful for tracing the activity on the target system. When the **State Log** window is open, it is updated continuously at runtime.

**Note:** There is a limit on the number of saved logs. When this limit is exceeded, the oldest entries in the buffer are erased.

See also *Displaying a power profile and analyzing the result*, page 242 and *Timeline window—State Log graph*, page 257.

### Requirements

An MSP430 device with JSTATE register and an eZFET or MSP-FET debug probe.

### Display area

This area contains these columns:

#### Time

The time for the state change, based on the sampling frequency.

If a time is displayed in italics, the target system has not been able to collect a correct time, but instead had to approximate it.

#### Source

The name of the peripheral unit, clock, or CPU mode.

#### Status

The status at the given time.

**Program Counter\***

The address of the program counter when the status changed, or shows **idle** if the log was taken during CPU idle mode, or shows --- for an unknown PC value.

**Active**

The active time calculated using the on and off time for the source. If it is written in italics, it is based on at least one approximative time.

\* You can double-click an address. If it is available in the source code, the editor window displays the corresponding source code, for example for the interrupt handler (this does not include library source code).

**Context menu**

This context menu is available:

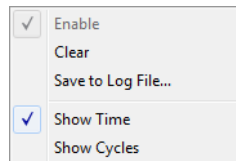

These commands are available:

**Enable**

Enables the logging system. The system will log information also when the window is closed.

**Clear**

Deletes the log information. Note that this will happen also when you reset the debugger.

**Save to File**

Displays a standard file selection dialog box where you can select the destination file for the log information. The entries in the log file are separated by TAB and LF characters. An **X** in the **Approx** column indicates that the timestamp is an approximation.

**Show Time**

Displays the **Time** column.

If the **Time** column is always displayed by default in the C-SPY driver you are using, this menu command is not available.

**Show Cycles**

Displays the **Cycles** column.

If the C-SPY driver you are using does not support the **Cycles** column, this menu command is not available.

## State Log Summary window

The **State Log Summary** window is available from the C-SPY driver menu.

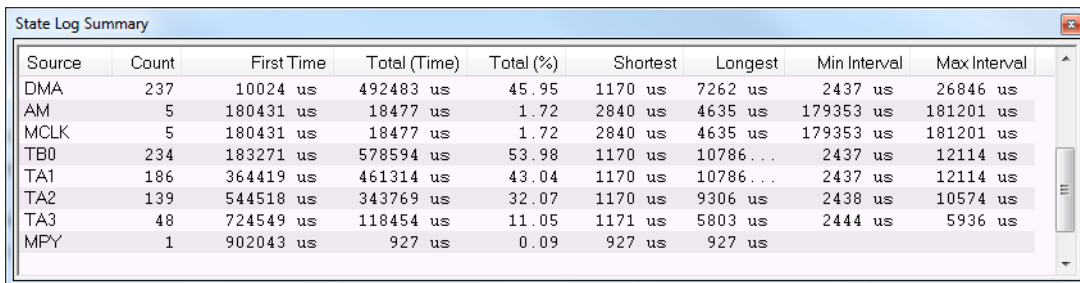

Source	Count	First Time	Total (Time)	Total (%)	Shortest	Longest	Min Interval	Max Interval
DMA	237	10024 us	492483 us	45.95	1170 us	7262 us	2437 us	26846 us
AM	5	180431 us	18477 us	1.72	2840 us	4635 us	179353 us	181201 us
MCLK	5	180431 us	18477 us	1.72	2840 us	4635 us	179353 us	181201 us
TB0	234	183271 us	578594 us	53.98	1170 us	10786...	2437 us	12114 us
TA1	186	364419 us	461314 us	43.04	1170 us	10786...	2437 us	12114 us
TA2	139	544518 us	343769 us	32.07	1170 us	9306 us	2438 us	10574 us
TA3	48	724549 us	118454 us	11.05	1171 us	5803 us	2444 us	5936 us
MPY	1	902043 us	927 us	0.09	927 us	927 us		

This window displays a summary of logged activity—state changes—for peripheral units and clocks, as well as for CPU modes.

Click a column to sort it according to the values. Click again to reverse the sort order.

At the bottom of the display area, the current time or cycles is displayed—the number of cycles or the execution time since the start of execution.

See also *Displaying a power profile and analyzing the result*, page 242 and *Timeline window—State Log graph*, page 257.

### Requirements

An MSP430 device with JSTATE register and an eZFET or MSP-FET debug probe.

### Display area

Each row in this area displays statistics about the specific measurement source based on the log information in these columns; and summary information is listed at the bottom of the display area:

#### Source

The name of the peripheral unit, clock, or CPU mode.

#### Count

The number of times the source was activated.

#### First time

The first time the source was activated.

**Total (Time)\*\***

The accumulated time the source has been active.

**Total (%)**

The accumulated time in percent that the source has been active.

**Shortest**

The shortest time spent with this source active.

**Longest**

The longest time spent with this source active.

**Min interval**

The shortest time between two activations of this source.

**Max interval**

The longest time between two activations of this source.

**Approximative time count**

The information displayed depends on the C-SPY driver you are using.

For some C-SPY drivers, this information is not displayed or the value is always zero. In this case, all logs have an exact time stamp.

For other C-SPY drivers, a non-zero value is displayed. The value represents the amount of logs with an approximative time stamp. This might happen if the bandwidth in the communication channel is too low compared to the amount of data packets generated by the CPU or if the CPU generated packets with an approximative time stamp.

**Overflow count**

The information displayed depends on the C-SPY driver you are using.

For some C-SPY drivers, this information is not displayed or the value is always zero.

For other C-SPY drivers, the number represents the amount of overflows in the communication channel which can cause logs to be lost. If this happens, it indicates that logs might be incomplete. To solve this, make sure not to use all C-SPY log features simultaneously or check used bandwidth for the communication channel.

**Current time|cycles**

The information displayed depends on the C-SPY driver you are using.

For some C-SPY drivers, the value is always zero or not visible at all.

For other C-SPY drivers, the number represents the current time or cycles—the number of cycles or the execution time since the start of execution.

\*\* Calculated in the same way as for the Execution time/cycles in the **State Log** window.

## Context menu

This context menu is available:

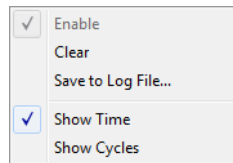

These commands are available:

### Enable

Enables the logging system. The system will log information also when the window is closed.

### Clear

Deletes the log information. Note that this will happen also when you reset the debugger.

### Save to File

Displays a standard file selection dialog box where you can select the destination file for the log information. The entries in the log file are separated by TAB and LF characters. An **X** in the **Approx** column indicates that the timestamp is an approximation.

### Show Time

Displays the **Time** column.

If the **Time** column is always displayed by default in the C-SPY driver you are using, this menu command is not available.

### Show Cycles

Displays the **Cycles** column.

If the C-SPY driver you are using does not support the **Cycles** column, this menu command is not available.



## Timeline window—State Log graph

The State Log graph in the **Timeline** window is available from the C-SPY driver menu during a debug session.

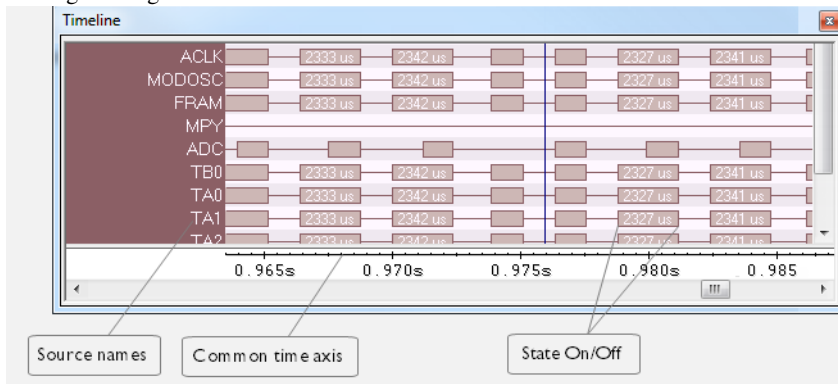

The **State Log** graph displays a graphical view of logged activity—state changes—for peripheral units and clocks, as well as CPU modes in relation to a common time axis.

**Note:** There is a limit on the number of saved logs. When this limit is exceeded, the oldest entries in the buffer are erased.

For more information about the **Timeline** window, how to display a graph, and the other supported graphs, see *Reference information on application timeline*, page 197.

See also, *Requirements and restrictions for power debugging*, page 237.

### Requirements

An MSP430 device with JSTATE register and an eZFET or MSP-FET debug probe.

### Display area

Where:

- The label area at the left end of the graph displays the name of the sources of the status information.
- The graph itself shows the state of the peripheral units, clocks, and CPU modes generated by the debug probe or associated hardware. The white figure indicates the time spent in the state. This graph is a graphical representation of the information in the **State Log** window, see *State Log window*, page 252.

At the bottom of the window, there is a shared time axis that uses seconds as the time unit.



# Part 3. Advanced debugging

This part of the *C-SPY® Debugging Guide for MSP430* includes these chapters:

- Interrupts
- The advanced cycle counter
- State storage
- The sequencer
- C-SPY macros
- The C-SPY command line utility—`cspybat`

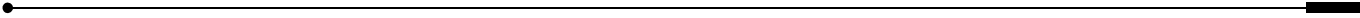



# Interrupts

- Introduction to interrupts
- Using the interrupt system
- Reference information on interrupts

---

## Introduction to interrupts

These topics are covered:

- Briefly about the interrupt simulation system
- Interrupt characteristics
- Interrupt simulation states
- C-SPY system macros for interrupt simulation
- Target-adapting the interrupt simulation system
- Briefly about interrupt logging

See also:

- *Reference information on C-SPY system macros*, page 319
- *Breakpoints*, page 103
- *The IAR C/C++ Compiler User Guide for MSP430*

### **BRIEFLY ABOUT THE INTERRUPT SIMULATION SYSTEM**

By simulating interrupts, you can test the logic of your interrupt service routines and debug the interrupt handling in the target system long before any hardware is available. If you use simulated interrupts in conjunction with C-SPY macros and breakpoints, you can compose a complex simulation of, for instance, interrupt-driven peripheral devices.

The C-SPY Simulator includes an interrupt simulation system where you can simulate the execution of interrupts during debugging. You can configure the interrupt simulation system so that it resembles your hardware interrupt system.

The interrupt system has the following features:

- Simulated interrupt support for the MSP430 microcontroller
- Single-occasion or periodical interrupts based on the cycle counter
- Predefined interrupts for various devices

- Configuration of hold time, probability, and timing variation
- State information for locating timing problems
- Configuration of interrupts using a dialog box or a C-SPY system macro—that is, one interactive and one automating interface. In addition, you can instantly force an interrupt.
- A log window that continuously displays events for each defined interrupt.
- A status window that shows the current interrupt activities.

All interrupts you define using the **Interrupt Setup** dialog box are preserved between debug sessions, unless you remove them. A forced interrupt, on the other hand, exists only until it has been serviced and is not preserved between sessions.



The interrupt simulation system is activated by default, but if not required, you can turn off the interrupt simulation system to speed up the simulation. To turn it off, use either the `INTERRUPTS OFF` or a system macro.

## INTERRUPT CHARACTERISTICS

The simulated interrupts consist of a set of characteristics which lets you fine-tune each interrupt to make it resemble the real interrupt on your target hardware. You can specify a *first activation time*, a *repeat interval*, a *hold time*, a *variance*, and a *probability*.

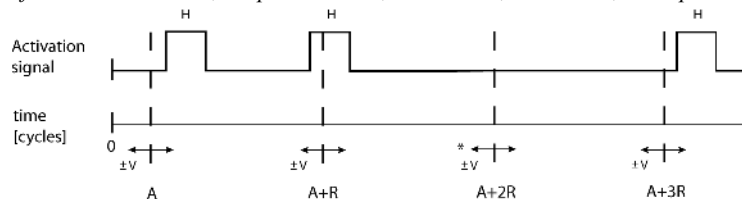

\* If probability is less than 100%, some interrupts may be omitted.

A = Activation time  
 R = Repeat interval  
 H = Hold time  
 V = Variance

The interrupt simulation system uses the cycle counter as a clock to determine when an interrupt should be raised in the simulator. You specify the *first activation time*, which is based on the cycle counter. C-SPY will generate an interrupt when the cycle counter has passed the specified activation time. However, interrupts can only be raised between instructions, which means that a full assembler instruction must have been executed before the interrupt is generated, regardless of how many cycles an instruction takes.

To define the periodicity of the interrupt generation you can specify the *repeat interval* which defines the amount of cycles after which a new interrupt should be generated. In addition to the repeat interval, the periodicity depends on the two options *probability*—

the probability, in percent, that the interrupt will actually appear in a period—and *variance*—a time variation range as a percentage of the repeat interval. These options make it possible to randomize the interrupt simulation. You can also specify a *hold time* which describes how long the interrupt remains pending until removed if it has not been processed. If the hold time is set to *infinite*, the corresponding pending bit will be set until the interrupt is acknowledged or removed.

## INTERRUPT SIMULATION STATES

The interrupt simulation system contains status information that you can use for locating timing problems in your application. The **Interrupt Status** window displays the available status information. For an interrupt, these states can be displayed: *Idle*, *Pending*, *Executing*, or *Suspended*.

Normally, a repeatable interrupt has a specified repeat interval that is longer than the execution time. In this case, the status information at different times looks like this:

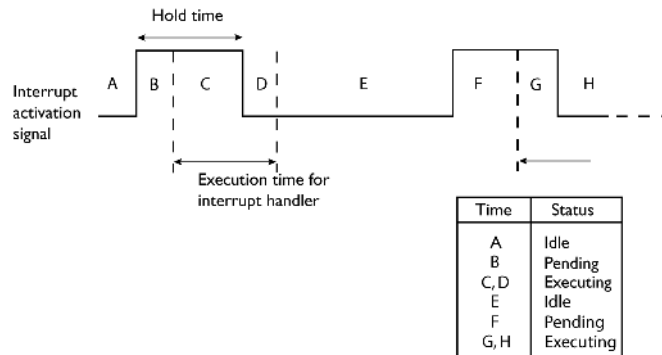

**Note:** The interrupt activation signal—also known as the pending bit—is automatically deactivated the moment the interrupt is acknowledged by the interrupt handler.

However, if the interrupt repeat interval is shorter than the execution time, and the interrupt is reentrant (or non-maskable), the status information at different times looks like this:

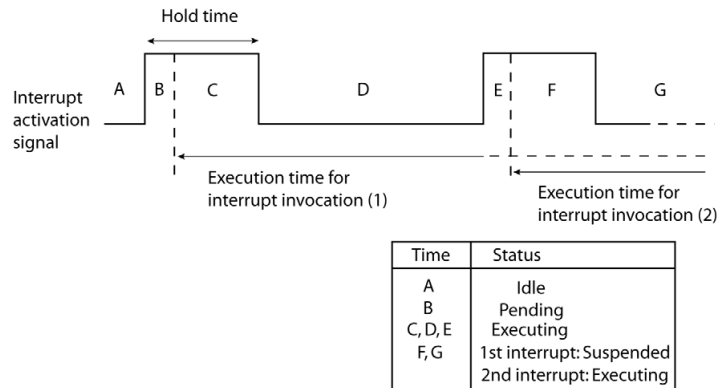

An execution time that is longer than the repeat interval might indicate that you should rewrite your interrupt handler and make it faster, or that you should specify a longer repeat interval for the interrupt simulation system.

## C-SPY SYSTEM MACROS FOR INTERRUPT SIMULATION

Macros are useful when you already have sorted out the details of the simulated interrupt so that it fully meets your requirements. If you write a macro function containing definitions for the simulated interrupts, you can execute the functions automatically when C-SPY starts. Another advantage is that your simulated interrupt definitions will be documented if you use macro files, and if you are several engineers involved in the development project you can share the macro files within the group.

The C-SPY Simulator provides these predefined system macros related to interrupts:

```
__enableInterrupts
__disableInterrupts
__orderInterrupt
__cancelInterrupt
__cancelAllInterrupts
__popSimulatorInterruptExecutingStack
```

The parameters of the first five macros correspond to the equivalent entries of the **Interrupt Setup** dialog box.



For more information about each macro, see *Reference information on C-SPY system macros*, page 319.

## TARGET-ADAPTING THE INTERRUPT SIMULATION SYSTEM

The interrupt simulation system is easy to use. However, to take full advantage of the interrupt simulation system you should be familiar with how to adapt it for the processor you are using.

The interrupt simulation has the same behavior as the hardware. This means that the execution of an interrupt is dependent on the status of the global interrupt enable bit. The execution of maskable interrupts is also dependent on the status of the individual interrupt enable bits.

To simulate device-specific interrupts, the interrupt system must have detailed information about each available interrupt. This information is provided in the device description files.

For information about device description files, see *Selecting a device description file*, page 44.

## BRIEFLY ABOUT INTERRUPT LOGGING

Interrupt logging provides you with comprehensive information about the interrupt events. This might be useful for example, to help you locate which interrupts you can fine-tune to become faster. You can log entrances and exits to and from interrupts. You can also log internal interrupt status information, such as triggered, expired, etc. In the IDE:

- The logs are displayed in the **Interrupt Log** window
- A summary is available in the **Interrupt Log Summary** window
- The Interrupt graph in the **Timeline** window provides a graphical view of the interrupt events during the execution of your application.

### Requirements for interrupt logging

Interrupt logging is supported by the C-SPY simulator.

See also *Getting started using interrupt logging*, page 268.

---

## Using the interrupt system

These tasks are covered:

- Simulating a simple interrupt
- Simulating an interrupt in a multi-task system

- Getting started using interrupt logging.

See also:

- *Using C-SPY macros*, page 307 for details about how to use a setup file to define simulated interrupts at C-SPY startup
- The tutorial *Simulating an interrupt* in the Information Center.

## SIMULATING A SIMPLE INTERRUPT

This example demonstrates the method for simulating a timer interrupt. However, the procedure can also be used for other types of interrupts.

### To simulate and debug an interrupt:

- 1 Assume this simple application which contains an interrupt service routine for the BasicTimer, which increments a tick variable. The main function sets the necessary status registers. The application exits when 100 interrupts have been generated.

```
#include "io430x41x.h"
#include <intrinsics.h>

volatile int ticks = 0;
void main (void)
{
    /* Timer setup code */
    WDTCTL = WDTPW + WDTHOLD;    /* Stop WDT */
    IE2 |= BTIE;                /* Enable BT interrupt */
    BTCTL = BTSSEL+BTIP2+BTIP1+BTIP0;
    __enable_interrupt();        /* Enable interrupts */

    while (ticks < 100);        /* Endless loop */
    printf("Done\n");
}

/* Timer interrupt service routine */
#pragma vector = BASICTIMER_VECTOR
__interrupt void basic_timer(void)
{
    ticks += 1;
}
```

- 2 Add your interrupt service routine to your application source code and add the file to your project.
- 3 Choose **Project>Options>Debugger>Setup** and select a device description file. The device description file contains information about the interrupt that C-SPY needs to be able to simulate it. Use the **Use device description file** browse button to locate the `ddf` file.

- 4 Build your project and start the simulator.
- 5 Choose **Simulator>Interrupt Setup** to open the **Interrupts Setup** dialog box. Select the **Enable interrupt simulation** option to enable interrupt simulation. Click **New** to open the **Edit Interrupt** dialog box. For the timer example, verify these settings:

Option	Settings
Interrupt	BASICTIMER_VECTOR
First activation	4000
Repeat interval	2000
Hold time	10
Probability (%)	100
Variance (%)	0

Table 12: Timer interrupt settings

Click **OK**.

- 6 Execute your application. If you have enabled the interrupt properly in your application source code, C-SPY will:
  - Generate an interrupt when the cycle counter has passed 4000
  - Continuously repeat the interrupt after approximately 2000 cycles.
- 7 To watch the interrupt in action, choose **Simulator>Interrupt Log** to open the Interrupt Log window.
- 8 From the context menu, available in the Interrupt Log window, choose **Enable** to enable the logging. If you restart program execution, status information about entrances and exits to and from interrupts will now appear in the Interrupt Log window.

For information about how to get a graphical representation of the interrupts correlated with a time axis, see *Timeline window—Interrupt Log graph*, page 280.

## SIMULATING AN INTERRUPT IN A MULTI-TASK SYSTEM

If you are using interrupts in such a way that the normal instruction used for returning from an interrupt handler is not used, for example in an operating system with task-switching, the simulator cannot automatically detect that the interrupt has finished executing. The interrupt simulation system will work correctly, but the status information in the **Interrupt Setup** dialog box might not look as you expect. If too many interrupts are executing simultaneously, a warning might be issued.

### To simulate a normal interrupt exit:

- 1 Set a code breakpoint on the instruction that returns from the interrupt function.

- 2 Specify the `__popSimulatorInterruptExecutingStack` macro as a condition to the breakpoint.

When the breakpoint is triggered, the macro is executed and then the application continues to execute automatically.

## GETTING STARTED USING INTERRUPT LOGGING

- 1 Choose *C-SPY driver*>**Interrupt Log** to open the **Interrupt Log** window. Optionally, you can also choose:
  - *C-SPY driver*>**Interrupt Log Summary** to open the **Interrupt Log Summary** window
  - *C-SPY driver*>**Timeline** to open the **Timeline** window and view the Interrupt graph.
- 2 From the context menu in the **Interrupt Log** window, choose **Enable** to enable the logging.
- 3 Start executing your application program to collect the log information.
- 4 To view the interrupt log information, look in any of the Interrupt Log, Interrupt Log Summary, or the Interrupt graph in the **Timeline** window.
- 5 If you want to save the log or summary to a file, choose **Save to log file** from the context menu in the window in question.
- 6 To disable interrupt logging, from the context menu in the **Interrupt Log** window, toggle **Enable** off.

---

## Reference information on interrupts

Reference information about:

- *Interrupt Setup dialog box*, page 269
- *Edit Interrupt dialog box*, page 271
- *Forced Interrupt window*, page 272
- *Interrupt Status window*, page 273
- *Interrupt Log window*, page 275
- *Interrupt Log Summary window*, page 277.
- *Timeline window—Interrupt Log graph*, page 280.

## Interrupt Setup dialog box

The **Interrupt Setup** dialog box is available by choosing **Simulator>Interrupt Setup**.

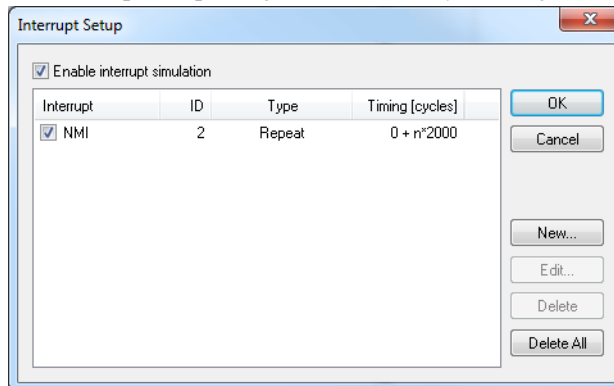

This dialog box lists all defined interrupts. Use this dialog box to enable or disable the interrupt simulation system, as well as to enable or disable individual interrupts.

See also *Using the interrupt system*, page 265.

### Requirements

The C-SPY simulator.

### Enable interrupt simulation

Enables or disables interrupt simulation. If the interrupt simulation is disabled, the definitions remain but no interrupts are generated. Note that you can also enable and disable installed interrupts individually by using the check box to the left of the interrupt name in the list of installed interrupts.

### Display area

This area contains these columns:

#### Interrupt

Lists all interrupts. Use the checkbox to enable or disable the interrupt.

#### ID

A unique interrupt identifier.

#### Type

Shows the type of the interrupt. The type can be one of:

**Forced**, a single-occasion interrupt defined in the Forced Interrupt Window.

**Single**, a single-occasion interrupt.

**Repeat**, a periodically occurring interrupt.

If the interrupt has been set from a C-SPY macro, the additional part (**macro**) is added, for example: **Repeat(macro)**.

### Timing

The timing of the interrupt. For a **Single** and **Forced** interrupt, the activation time is displayed. For a **Repeat** interrupt, the information has the form: `Activation Time + n*Repeat Time`. For example, `2000 + n*2345`. This means that the first time this interrupt is triggered, is at 2000 cycles and after that with an interval of 2345 cycles.

### Buttons

These buttons are available:

#### New

Opens the **Edit Interrupt** dialog box, see *Edit Interrupt dialog box*, page 271.

#### Edit

Opens the **Edit Interrupt** dialog box, see *Edit Interrupt dialog box*, page 271.

#### Delete

Removes the selected interrupt.

#### Delete All

Removes all interrupts.

## Edit Interrupt dialog box

The **Edit Interrupt** dialog box is available from the **Interrupt Setup** dialog box.

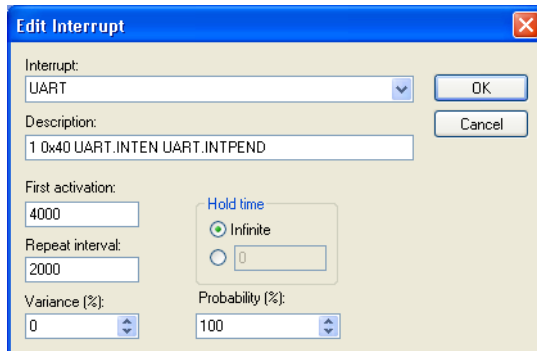

Use this dialog box to interactively fine-tune the interrupt parameters. You can add the parameters and quickly test that the interrupt is generated according to your needs.

**Note:** You can only edit or remove non-forced interrupts.

See also *Using the interrupt system*, page 265.

### Requirements

The C-SPY simulator.

### Interrupt

Selects the interrupt that you want to edit. The drop-down list contains all available interrupts. Your selection will automatically update the **Description** box. The list is populated with entries from the device description file that you have selected.

### Description

A description of the selected interrupt, if available. The description is retrieved from the selected device description file and consists of a string describing the vector address, the default priority, enable bit, and pending bit, separated by space characters. For interrupts specified using the system macro `__orderInterrupt`, the **Description** box is empty.

### First activation

Specify the value of the cycle counter after which the specified type of interrupt will be generated.

### Repeat interval

Specify the periodicity of the interrupt in cycles.

**Variance %**

Selects a timing variation range, as a percentage of the repeat interval, in which the interrupt might occur for a period. For example, if the repeat interval is 100 and the variance 5%, the interrupt might occur anywhere between  $T=95$  and  $T=105$ , to simulate a variation in the timing.

**Hold time**

Specify how long, in cycles, the interrupt remains pending until removed if it has not been processed. If you select **Infinite**, the corresponding pending bit will be set until the interrupt is acknowledged or removed.

**Probability %**

Selects the probability, in percent, that the interrupt will actually occur within the specified period.

**Forced Interrupt window**

The **Forced Interrupt** window is available from the C-SPY driver menu.

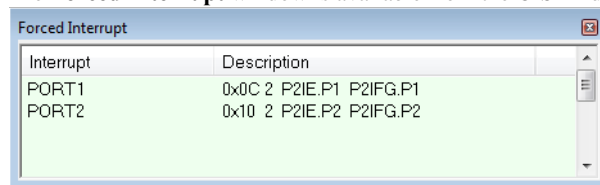

Use this window to force an interrupt instantly. This is useful when you want to check your interrupt logic and interrupt routines. Just start typing an interrupt name and focus shifts to the first line found with that name.

The hold time for a forced interrupt is infinite, and the interrupt exists until it has been serviced or until a reset of the debug session.

To sort the window contents, click on either the **Interrupt** or the **Description** column header. A second click on the same column header reverses the sort order.

**To force an interrupt:**

- 1 Enable the interrupt simulation system, see *Interrupt Setup dialog box*, page 269.
- 2 Double-click the interrupt in the **Forced Interrupt** window, or activate it by using the **Force** command available on the context menu.

**Requirements**

The C-SPY simulator.



**Display area**

This area lists all available interrupts and their definitions. The description field is editable and the information is retrieved from the selected device description file. See this file for a detailed description.

**Context menu**

This context menu is available:

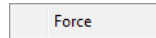

This command is available:

**Force**

Triggers the interrupt you selected in the display area.

**Interrupt Status window**

The **Interrupt Status** window is available from the C-SPY driver menu.

Interrupt	Id	Type	Status	Next Time	Timing [cycles]
NMI	2	Forced	Executing	--	--
IRQ0	1	Repeat (macro)	Suspended	--	--
NMI	0	Repeat	Idle	4345	2000 + n*2345
IRQ0	1	Repeat (macro)	Idle	5020	3010 + n*2010

This window shows the status of all the currently active interrupts, in other words interrupts that are either executing or waiting to be executed.

**Requirements**

The C-SPY simulator.

**Display area**

This area contains these columns:

**Interrupt**

Lists all interrupts.

**ID**

A unique interrupt identifier.

### Type

The type of the interrupt. The type can be one of:

**Forced**, a single-occasion interrupt defined in the Forced Interrupt window.

**Single**, a single-occasion interrupt.

**Repeat**, a periodically occurring interrupt.

If the interrupt has been set from a C-SPY macro, the additional part (**macro**) is added, for example: **Repeat(macro)**.

### Status

The state of the interrupt:

**Idle**, the interrupt activation signal is low (deactivated).

**Pending**, the interrupt activation signal is active, but the interrupt has not been yet acknowledged by the interrupt handler.

**Executing**, the interrupt is currently being serviced, that is the interrupt handler function is executing.

**Suspended**, the interrupt is currently suspended due to execution of an interrupt with a higher priority.

**(deleted)** is added to **Executing** and **Suspended** if you have deleted a currently active interrupt. **(deleted)** is removed when the interrupt has finished executing.

### Next Time

The next time an idle interrupt is triggered. Once a repeatable interrupt starts executing, a copy of the interrupt will appear with the state Idle and the next time set. For interrupts that do not have a next time—that is pending, executing, or suspended—the column will show --.

### Timing

The timing of the interrupt. For a **Single** and **Forced** interrupt, the activation time is displayed. For a **Repeat** interrupt, the information has the form:  $\text{Activation Time} + n * \text{Repeat Time}$ . For example,  $2000 + n * 2345$ . This means that the first time this interrupt is triggered, is at 2000 cycles and after that with an interval of 2345 cycles.

## Interrupt Log window

The **Interrupt Log** window is available from the C-SPY driver menu.

Time	Interrupt	Status	Program Counter	Execution Time
109.32 us	IRQT0	Triggered	0x13E8	
111.26 us	IRQT0	Enter	0x13F0	
135.78 us	IRQT1	Enter	0x1126	
148.72 us	IRQT1	Leave	0x1378	12.94 us
<i>189.34 us</i>	<b>Overflow</b>			
207.30 us	IRQT0	Leave	0x1126	96.04 us
230.00 us	IRQT0	Triggered	0x1110	
231.34 us	IRQT0	Enter	0x1126	
240.26 us	IRQT0	Leave	0x1122	8.92 us
300.00 us	IRQT1	Enter	---	
371.12 us	IRQT1	Leave	0x1120	71.12 us

Red indicates overflows and italic indicates approximate values

Light-colored rows indicate entrances to interrupts

Darker rows indicate exits from interrupts

This window logs entrances to and exits from interrupts. The C-SPY simulator also logs internal state changes.

The information is useful for debugging the interrupt handling in the target system. When the **Interrupt Log** window is open, it is updated continuously at runtime.

**Note:** There is a limit on the number of saved logs. When this limit is exceeded, the oldest entries in the buffer are erased.

For more information, see *Getting started using interrupt logging*, page 268.

For information about how to get a graphical view of the interrupt events during the execution of your application, see *Timeline window—Interrupt Log graph*, page 280.

### Display area

This area contains these columns:

#### Time

The point in time, measured in seconds, when the event occurred.

This column is available when you have selected **Show Time** from the context menu.

#### Cycles

The number of cycles from the start of the execution until the event.

This column is available when you have selected **Show Cycles** from the context menu.

### Interrupt

The interrupt as defined in the device description file.

### Status

Shows the event status of the interrupt:

**Triggered**, the interrupt has passed its activation time.

**Forced**, the same as Triggered, but the interrupt was forced from the Forced Interrupt window.

**Enter**, the interrupt is currently executing.

**Leave**, the interrupt has been executed.

**Expired**, the interrupt hold time has expired without the interrupt being executed.

**Rejected**, the interrupt has been rejected because the necessary interrupt registers were not set up to accept the interrupt.

### Program Counter

The value of the program counter when the event occurred.

### Execution Time/Cycles

The time spent in the interrupt, calculated using the Enter and Leave timestamps. This includes time spent in any subroutines or other interrupts that occurred in the specific interrupt.

## Context menu

This context menu is available:

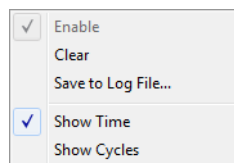

These commands are available:

### Enable

Enables the logging system. The system will log information also when the window is closed.

**Clear**

Deletes the log information. Note that this will happen also when you reset the debugger.

**Save to File**

Displays a standard file selection dialog box where you can select the destination file for the log information. The entries in the log file are separated by TAB and LF characters. An X in the **Approx** column indicates that the timestamp is an approximation.

**Show Time**

Displays the **Time** column.

If the **Time** column is displayed by default in the C-SPY driver you are using, this menu command is not available.

**Show Cycles**

Displays the **Cycles** column.

If the **Cycles** column is not supported in the C-SPY driver you are using, this menu command is not available.

## Interrupt Log Summary window

The **Interrupt Log Summary** window is available from the C-SPY driver menu.

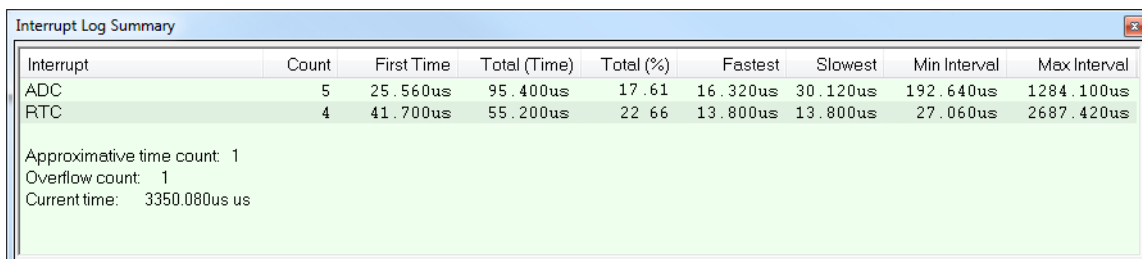

Interrupt	Count	First Time	Total (Time)	Total (%)	Fastest	Slowest	Min Interval	Max Interval
ADC	5	25.560us	95.400us	17.61	16.320us	30.120us	192.640us	1284.100us
RTC	4	41.700us	55.200us	22.66	13.800us	13.800us	27.060us	2687.420us

Approximative time count: 1  
 Overflow count: 1  
 Current time: 3350.080us us

This window displays a summary of logs of entrances to and exits from interrupts.

For more information, see *Getting started using interrupt logging*, page 268.

For information about how to get a graphical view of the interrupt events during the execution of your application, see *Timeline window—Interrupt Log graph*, page 280.

**Requirements**

The C-SPY simulator.

## Display area

Each row in this area displays statistics about the specific interrupt based on the log information in these columns:

### Interrupt

The type of interrupt that occurred.

At the bottom of the column, the current time or cycles is displayed—the number of cycles or the execution time since the start of execution.

### Count

The number of times the interrupt occurred.

### First time

The first time the interrupt was executed.

### Total (Time)\*\*

The accumulated time spent in the interrupt.

### Total (%)

The time in percent of the current time.

### Fastest\*\*

The fastest execution of a single interrupt of this type.

### Slowest\*\*

The slowest execution of a single interrupt of this type.

### Min interval

The shortest time between two interrupts of this type.

The interval is specified as the time interval between the entry time for two consecutive interrupts.

### Max interval

The longest time between two interrupts of this type.

The interval is specified as the time interval between the entry time for two consecutive interrupts.

\*\* Calculated in the same way as for the Execution time/cycles in the **Interrupt Log** window.

## Context menu

This context menu is available:

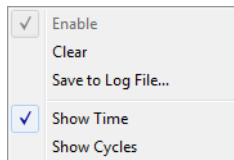

These commands are available:

### Enable

Enables the logging system. The system will log information also when the window is closed.

### Clear

Deletes the log information. Note that this will happen also when you reset the debugger.

### Save to File

Displays a standard file selection dialog box where you can select the destination file for the log information. The entries in the log file are separated by `TAB` and `LF` characters. An **X** in the **Approx** column indicates that the timestamp is an approximation.

### Show Time

Displays the **Time** column.

If the **Time** column is displayed by default in the C-SPY driver you are using, this menu command is not available.

### Show Cycles

Displays the **Cycles** column.

If the **Cycles** column is not supported in the C-SPY driver you are using, this menu command is not available.

## Timeline window—Interrupt Log graph

The Interrupt Log graph displays interrupts collected by the trace system. In other words, the graph provides a graphical view of the interrupt events during the execution of your application.

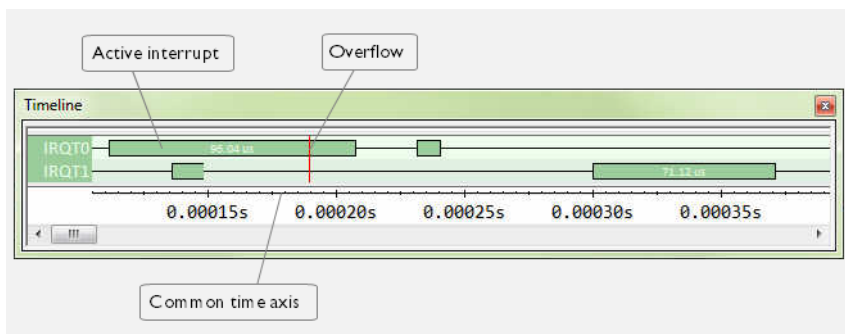

**Note:** There is a limit on the number of saved logs. When this limit is exceeded, the oldest entries in the buffer are erased.

### Display area

- The label area at the left end of the graph displays the names of the interrupts.
- The graph itself shows active interrupts as a thick green horizontal bar where the white figure indicates the time spent in the interrupt. This graph is a graphical representation of the information in the **Interrupt Log** window, see *Interrupt Log window*, page 275.
- If the bar is displayed without horizontal borders, there are two possible causes:
  - The interrupt is reentrant and has interrupted itself. Only the innermost interrupt will have borders.
  - There are irregularities in the interrupt enter-leave sequence, probably due to missing logs.
- If the bar is displayed without a vertical border, the missing border indicates an approximate time for the log.
- A red vertical line indicates overflow, which means that the communication channel failed to transmit all interrupt logs from the target system.

At the bottom of the window, there is a common time axis that uses seconds as the time unit.



## Context menu

This context menu is available:

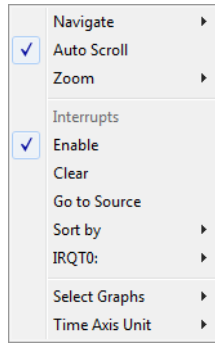

**Note:** The exact contents of the context menu you see on the screen depends on which features that your combination of software and hardware supports. However, the list of menu commands below is complete and covers all possible commands.

These commands are available:

### Navigate

Commands for navigating the graph(s). Choose between:

**Next** moves the selection to the next relevant point in the graph. Shortcut key: right arrow.

**Previous** moves the selection backward to the previous relevant point in the graph. Shortcut key: left arrow.

**First** moves the selection to the first data entry in the graph. Shortcut key: Home.

**Last** moves the selection to the last data entry in the graph. Shortcut key: End.

**End** moves the selection to the last data in any displayed graph, in other words the end of the time axis. Shortcut key: Ctrl+End.

### Auto Scroll

Toggles automatic scrolling on or off. When on, the most recently collected data is automatically displayed when you choose **Navigate>End**.

### Zoom

Commands for zooming the window, in other words, changing the time scale. Choose between:

**Zoom to Selection** makes the current selection fit the window. Shortcut key: Return.

**Zoom In** zooms in on the time scale. Shortcut key: +

**Zoom Out** zooms out on the time scale. Shortcut key: –

**10ns, 100ns, 1us**, etc makes an interval of 10 nanoseconds, 100 nanoseconds, 1 microsecond, respectively, fit the window.

**1ms, 10ms**, etc makes an interval of 1 millisecond or 10 milliseconds, respectively, fit the window.

**10m, 1h**, etc makes an interval of 10 minutes or 1 hour, respectively, fit the window.

### **Interrupt**

A heading that shows that the Interrupt Log-specific commands below are available.

### **Enable**

Toggles the display of the graph on or off. If you disable a graph, that graph will be indicated as **OFF** in the window. If no data has been collected for a graph, **no data** will appear instead of the graph.

### **Clear**

Deletes the log information. Note that this will happen also when you reset the debugger.

### **Go To Source**

Displays the corresponding source code in an editor window, if applicable.

### **Sort by**

Sorts the entries according to their ID or name. The selected order is used in the graph when new interrupts appear.

### *source*

Goes to the previous/next log for the selected source.

### **Select Graphs**

Selects which graphs to be displayed in the **Timeline** window.

### **Time Axis Unit**

Selects the unit used in the time axis; choose between **Seconds** and **Cycles**.

If **Cycles** is not available, the graphs are based on different clock sources. In that case you can view cycle values as tooltip information by pointing at the graph with your mouse pointer.

# The advanced cycle counter

- Introduction to the advanced cycle counter
- Using the cycle counter applications
- Reference information on the advanced cycle counter.

---

## Introduction to the advanced cycle counter

This section introduces the advanced cycle counter.

These topics are covered:

- Reasons for using the advanced cycle counter
- Briefly about the advanced cycle counter
- Requirements for using the advanced cycle counter.

For related information, see *Registers window*, page 159.

### REASONS FOR USING THE ADVANCED CYCLE COUNTER

The advanced cycle counter for MSP430 devices can help you, for example, to measure the DMA load, to profile a part of your application, or to measure how long some tasks take.

### BRIEFLY ABOUT THE ADVANCED CYCLE COUNTER

The advanced cycle counter provides one or two 40-bit counters to count the number of cycles used by the CPU to execute certain tasks. On some devices, the cycle counter operation can be controlled using triggers. This allows, for example, conditional profiling, such as profiling a specific section of code.

The **Advanced Cycle Counter Control** window contains preconfigured *applications*, as well as the opportunity to customize your own use of the cycle counter.

### REQUIREMENTS FOR USING THE ADVANCED CYCLE COUNTER

The advanced cycle counter is only available if you are using the C-SPY FET Debugger driver and an MSP430 device that supports the Enhanced Emulation Module at the

required level. Some devices have one cycle counter and some have two. If your device has one cycle counter, it is referred to as Cycle counter 0. If your device has two cycle counters, they are referred to as Cycle counter 0 and Cycle counter 1.

---

## Using the cycle counter applications

This section gives you descriptions of the Cycle counter 1 applications available in the **Advanced Cycle Counter Control** window; that is, step-by-step descriptions of how to use the extra cycle counter.

More specifically, you will get information about:

- Counting all CPU cycles
- Measuring the DMA load versus the CPU load
- Profiling a specific part of your application
- Measuring the Trigger hits
- Measuring the number of CPU cycles for a task.

### COUNTING ALL CPU CYCLES

The **Cycle counter** application in the **Advanced Cycle Counter Control** window makes Cycle counter 1 behave like an ordinary cycle counter, counting all CPU cycles.

**To count all CPU cycles:**

- 1** Choose **Emulator>Advanced Cycle Counter** to open the **Advanced Cycle Counter Control** window.
- 2** Select the **Cycle counter** option.
- 3** Click the **Reset Counter 1** button to reset Cycle counter 1.
- 4** Execute your program and then stop the execution.

Cycle counter 1 in the **Cycle Counter Values** area now shows the number of CPU cycles that were executed.

### MEASURING THE DMA LOAD VERSUS THE CPU LOAD

The **DMA load vs. CPU load** application in the **Advanced Cycle Counter Control** window measures the DMA load versus the CPU load by comparing the number of DMA bus cycles with the total number of bus cycles.

**To measure the DMA load versus the CPU load:**

- 1** Choose **Emulator>Advanced Cycle Counter** to open the **Advanced Cycle Counter Control** window.

- 2 Select the **DMA load vs. CPU load** option.
- 3 Click the **Reset Counter 1** button to reset Cycle counter 1.
- 4 Execute your program and then stop the execution.

In the **Cycle Counter Values** area, Cycle counter 1 now shows the number of DMA bus cycles, which can be compared with the number of CPU cycles shown by cycle counter 0.

## PROFILING A SPECIFIC PART OF YOUR APPLICATION

The **Profiling** application in the **Advanced Cycle Counter Control** window lets you profile a specific part of your program. Two reaction triggers or breakpoints define the start and stop points for the cycle counter. Cycle counter 1 starts to count cycles at the first trigger point and stops counting cycles at the second trigger.

**Note:** You cannot define which trigger point should be used as the start point or stop point; the first of the two that is reached will start the cycle counter. The execution does not stop at any of the triggers. You can compare the amount of time spent in a specific function with the result for cycle counter 0, which counts all cycles for the entire application.

### To profile a section of your application:

- 1 Set up an advanced trigger at the start point of the code section that you want to measure. For information about setting advanced trigger breakpoints, see *Advanced trigger breakpoints*, page 105.
- 2 Set up a second advanced trigger at the stop point of the code section that you want to measure.
- 3 Choose **Emulator>Advanced Cycle Counter** to open the **Advanced Cycle Counter Control** window.
- 4 Select the **Profiling** option.
- 5 Select the start trigger point from the drop-down list **Reaction trigger 1**.
- 6 Select the stop trigger point from the drop-down list **Reaction trigger 2**.
- 7 Click the **Reset Counter 1** button to reset Cycle counter 1.
- 8 Execute your program and then stop the execution.

In the **Cycle Counter Values** area, Cycle counter 1 shows the number of CPU cycles spent in the selected code section or function. Cycle counter 0 shows all counted CPU cycles.

## MEASURING THE TRIGGER HITS

The **Trigger hits** application in the **Advanced Cycle Counter Control** window measures the number of times a certain point in your program has been reached. Cycle counter 1 counts the number of times a trigger point has been triggered.

### To measure how many times a point in your application is reached:

- 1** Set up an advanced trigger at the trigger point that you want to measure. For information about setting advanced trigger breakpoints, see *Advanced Trigger breakpoints dialog box*, page 130.
- 2** Choose **Emulator>Advanced Cycle Counter** to open the **Advanced Cycle Counter Control** window.
- 3** Select the **Trigger hits** option.
- 4** Select the trigger point from the drop-down list **Reaction trigger 1**.
- 5** Click the **Reset Counter 1** button to reset Cycle counter 1.
- 6** Execute your program and then stop the execution.

In the **Cycle Counter Values** area, Cycle counter 1 now shows the number of times the trigger point has been triggered.

## MEASURING THE NUMBER OF CPU CYCLES FOR A TASK

The **Trip counter** application in the **Advanced Cycle Counter Control** window measures the number of CPU cycles required to execute a certain task or function. Cycle counter 1 starts to count cycles at the start trigger and stops counting cycles at the stop trigger. The execution stops when the stop trigger is reached.

### To measure the number of cycles required to execute a task or function:

- 1** Set up an advanced trigger at the start point of the code section that you want to measure. For information about setting advanced trigger breakpoints, see *Advanced Trigger breakpoints dialog box*, page 130.
- 2** Set up a second advanced trigger at the stop point of the code section that you want to measure.
- 3** Choose **Emulator>Advanced Cycle Counter** to open the **Advanced Cycle Counter Control** window.
- 4** Select the **Trip counter** option.
- 5** Select the start trigger point from the drop-down list **Reaction trigger 1**.
- 6** Select the stop trigger point from the drop-down list **Reaction trigger 2**.
- 7** Click the **Reset Counter 1** button to reset Cycle counter 1.

- 8 Execute your program. The execution stops when the stop trigger is reached.

In the **Cycle Counter Values** area, Cycle counter 1 now shows the number of CPU cycles required to execute the task or function.

## Reference information on the advanced cycle counter

This section gives reference information about the *Advanced Cycle Counter Control window*.

### Advanced Cycle Counter Control window

The **Advanced Cycle Counter Control** window is available from the **Emulator** menu when the debugger is running.

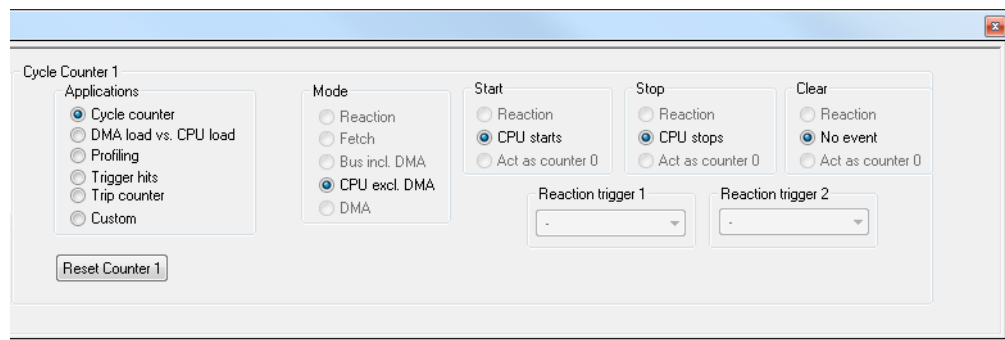

Use this window to set the behavior of Cycle counter 0 and Cycle counter 1, the extra cycle counter for some MSP430 devices.

#### Requirements

The C-SPY FET Debugger driver.

#### Applications

The **Advanced Cycle Counter Control** window contains preconfigured *applications* for Cycle counter 1, as well as the opportunity to customize your own use of the cycle counter. Use the cycle counter **Applications** to configure for what purpose to use the cycle counter. Choose between:

##### Cycle counter

Makes Cycle counter 1 count all CPU cycles; see *Counting all CPU cycles*, page 284.

### **DMA load vs. CPU load**

Compares the number of DMA bus cycles with the total number of bus cycles; see *Measuring the DMA load versus the CPU load*, page 284.

### **Profiling**

Profiles a specific part of your program; see *Profiling a specific part of your application*, page 285.

### **Trigger hits**

Measures the number of times a certain point in your program has been reached; see *Measuring the Trigger hits*, page 286.

### **Trip counter**

Measures the number of CPU cycles required to execute a certain task or function; see *Measuring the number of CPU cycles for a task*, page 286.

### **Custom**

Make a custom application using the options in the **Cycle Counter 1** area.

## **Cycle counter values**

### **Cycle counter 0**

The value of cycle counter 0. Cycle counter 0 is the same cycle counter as the one displayed in the **Register** window.

### **Cycle counter 1**

The value of Cycle counter 1. Cycle counter 1 is controlled by the settings in the **Advanced Cycle Counter Control** window.

## **Mode**

### **Reaction**

Increments the counter on reactions. This option is only available for Cycle counter 1.

### **Fetch**

Increments the counter on all instruction fetch cycles.

### **Bus incl. DMA**

Increments the counter on all bus cycles (including DMA cycles).

### **CPU excl. DMA**

Increments the counter on all CPU bus cycles (excluding DMA cycles).

### **DMA**

Increments the counter on all DMA bus cycles.



**Start****Reaction**

Uses the cycle counter reaction to start the cycle counter. This option is only available for Cycle counter 1.

**CPU starts**

Starts counting cycles when the CPU starts to execute.

**Act as counter 0/1**

Starts counting when the other counter starts. This option is only available for devices with two cycle counters.

**Stop****Reaction**

Uses the cycle counter reaction to stop the cycle counter. This option is only available for Cycle counter 1.

**CPU stops**

Stops counting when the CPU stops the execution.

**Act as counter 0/1**

Stops counting when the other counter stops. This option is only available for devices with two cycle counters.

**Clear****Reaction**

Clears the cycle counter on the cycle count reaction. This option is only available for Cycle counter 1.

**No event**

Does not clear the counter.

**Act as counter 0/1**

Clears the cycle counter when the other automatically resets.

**Combinations of start, stop, and clear reactions**

<b>Start</b>	<b>Stop</b>	<b>Clear</b>	<b>Description</b>
<b>Reaction</b>		<b>Reaction</b>	The cycle counter reaction starts the cycle counter and clears it at start.

*Table 13: Cycle Counter 1, combinations of start, stop, and clear reactions*

<b>Start</b>	<b>Stop</b>	<b>Clear</b>	<b>Description</b>
	<b>Reaction</b>	<b>Reaction</b>	The cycle counter reaction stops and clears the cycle counter.
<b>Reaction</b>	<b>Reaction</b>		If the cycle counter is stopped, the cycle counter reaction starts the counter. If the counter is running, the cycle counter reaction stops the counter.
<b>Reaction</b>	<b>Reaction</b>	<b>Reaction</b>	If the cycle counter is stopped, the cycle counter reaction starts the counter and clears it at start. If the counter is running, the cycle counter reaction stops the counter.

*Table 13: Cycle Counter 1, combinations of start, stop, and clear reactions*

### **Reaction trigger 1, Reaction trigger 2**

Selects breakpoints to act as a reaction triggers.

### **Reset Counter 0/1**

Resets the value and state of the cycle counter.

# State storage

- Introduction to state storage
- Using state storage
- Reference information on state storage.

---

## Introduction to state storage

This section introduces the state storage module, a limited variant of a traditional trace module available for the C-SPY FET Debugger driver.

These topics are covered:

- Reasons for using state storage
- Briefly about state storage
- Requirements.

For related information, see also:

- *The sequencer*, page 299.

### REASONS FOR USING STATE STORAGE

State storage allows you to examine the last eight states or instructions that were executed before a specific point was reached or a specific event occurred, or the next eight states that will be executed after a specific point is reached or a specific event occurs.

### BRIEFLY ABOUT STATE STORAGE

The state storage module is a limited variant of a traditional trace module. It can store eight states and can be used for monitoring program states or program flow, without interfering with the execution. It uses a built-in buffer to store MAB, MDB, and CPU control signal information.

### REQUIREMENTS

The state storage module is only available if you are using the C-SPY FET Debugger driver and a device that supports the Enhanced Emulation Module at the required level.

---

## Using state storage

This section gives you step-by-step descriptions about how to use certain features related to state storage.

- More specifically, you will get information about:  
Setting up state storage.

### SETTING UP STATE STORAGE

**To use the state storage module, you must:**

- 1 Define one or several range breakpoints or conditional breakpoints.
- 2 In the breakpoints dialog box, select the action **State Storage Trigger** for these breakpoints. This means that the breakpoint is defined as a state storage trigger. (State storage can also be triggered from the **Sequencer Control** window.)

**Note:** Depending on the behavior you want when the state storage module is triggered, it is useful to consider the combination of the **Action** options and the options available in the **State Storage Control** window. See the examples following immediately after these steps.

- 3 Choose **Emulator>State Storage Control** to open the **State Storage Control** window.
- 4 Select the option **Enable state storage**. Set the options **Buffer wrap around**, **Trigger action**, and **Storage action** according to your preferences.

In the list **State Storage Triggers**, all breakpoints defined as state storage triggers are listed.

For more details about the options, see *State Storage Control window*, page 294.

- 5 Click **Apply**.
- 6 Choose **Emulator>State Storage window** to open the State Storage window.
- 7 Choose **Debug>Go** to execute your application. Before you can view the state storage information, you must stop the execution. You can do this, for instance, by using the **Break** command.

For information about the window contents, see *State Storage window*, page 296.

### Example

As an example, assume the following setup:

- There is a conditional breakpoint which has both of the action options selected—**Break** and **State Storage Trigger**

- The state storage options **Instruction fetch** and **Buffer wrap around** are selected in the **State Storage Control** window.

This will start the state storage immediately when you start executing your application. When the breakpoint is triggered, the execution will stop and the last eight states can be inspected in the **State Storage** window.

However, if you do not want the state storage module to start until a specific state is reached, you would usually not want the execution to stop, because no state information has been stored yet.

In this case, select the **State Storage Trigger** action in the **Conditional breakpoints** dialog box (making sure that **Break** is deselected), and deselect the option **Buffer wrap around** in the **State Storage Control** window.

When the breakpoint is triggered, the execution will not stop, but the state storage will start. Because the option **Buffer wrap around** is deselected, you have ensured that the data in the buffer will not be overwritten.

When another breakpoint (which has **Break** selected) is triggered, or if you stop the execution by clicking the **Break** button, the **State Storage** window will show eight states starting with the breakpoint that was used for starting the state storage module.

---

## Reference information on state storage

This section gives reference information about these windows:

- *State Storage Control window*, page 294
- *State Storage window*, page 296.

## State Storage Control window

The **State Storage Control** window is available from the **Emulator** menu.

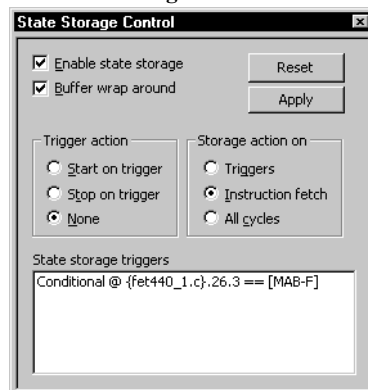

Use this window to define how to use the state storage module. The window is only available for devices that support the Enhanced Emulation Module at the required level.

### Requirements

The C-SPY FET Debugger driver.

### Enable state storage

Enables the state storage module.

### Buffer wrap around

Determines whether the state storage buffer should wrap around. If you select this option, the state storage buffer is continuously overwritten until the execution is stopped or a breakpoint is triggered. Only the eight last states are stored.

Alternatively, in order not to overwrite the information in the state storage buffer, deselect this option. To guarantee that the eight first states will be stored, you should also click **Reset**.

### Reset

Resets the state storage module.

**Trigger action**

Selects which action to take when breakpoints defined as state storage triggers are triggered:

**Start on trigger**

Starts state storage when the breakpoint is triggered.

**Stop on trigger**

Starts state storage immediately when execution starts. State storage stops when the breakpoint is triggered.

**None**

Starts state storage immediately when execution starts. State storage does not stop when the breakpoint is triggered. However, if execution stops, state storage also stops but it will resume when execution resumes.

**Storage action on**

Selects when the state information should be collected:

**Triggers**

Stores state information at the time when the state storage trigger is triggered. That is, when the breakpoint defined as a state storage trigger is triggered.

**Instruction fetch**

Stores state information at all instruction fetches.

**All cycles**

Stores state information for all cycles.

**State storage triggers**

Lists all the breakpoints that are defined as state storage triggers. That is, the breakpoints that have the action **State Storage Trigger** selected.

## State Storage window

The **State Storage** window is available from the **Emulator** menu.

Address bus...	Instr.	Mnemonic	Data bus ...	Control Signals ...	Control Signals...
0x1100	31400A	mov.w #0xA00,SP	0x4031	0x03	Break Trig. = 0; ...
0x1104	B0121211	call #main	0x12B0	0x03	Break Trig. = 0; ...
0x0000	----	????	0x0000	0x00	Break Trig. = 0; ...
0x0000	----	????	0x0000	0x00	Break Trig. = 0; ...
0x0000	----	????	0x0000	0x00	Break Trig. = 0; ...
0x0000	----	????	0x0000	0x00	Break Trig. = 0; ...
0x0000	----	????	0x0000	0x00	Break Trig. = 0; ...
0x0000	----	????	0x0000	0x00	Break Trig. = 0; ...

This window displays state storage information for eight states. Invalid data is displayed in red color.

### Requirements

The C-SPY FET Debugger driver.

### Toolbar

The toolbar contains:

#### Update

Refreshes the data in the **State Storage** window, alternatively appends new data.

#### Automatic update

Updates the data in the state storage window automatically each time new data is available in the state storage buffer.

#### Automatic restart

Resets the state storage module for consecutive data readouts after each readout.

#### Append data

Appends collected data from the state storage buffer to the data that is already present in the State Storage window. The new data is added below the data that is already present.

### Display area

This area contains these columns:

#### Address bus

The stored value of the address bus.



**Instruction**

The instruction.

**Mnemonic**

The mnemonic.

**Data bus**

The stored content of the data bus.



# The sequencer

- Introduction to the sequencer
- Using the sequencer
- Reference information on the sequencer.

---

## Introduction to the sequencer

This section introduces the sequencer module.

These topics are covered:

- *Reasons for using the sequencer*, page 299
- *Briefly about the sequencer*, page 299
- *Requirements for using the sequencer*, page 300.

For related information, see also:

- *State storage*, page 291.

### REASONS FOR USING THE SEQUENCER

The sequencer is useful if you, for instance, want to stop the execution or start the state storage module under certain conditions, for instance a specific program flow. If you combine this with letting the state storage module continuously store information, you will have useful state information logged in the State Storage window when the execution stops.

### BRIEFLY ABOUT THE SEQUENCER

The sequencer module is a simple state machine that lets you break the execution or trigger the state storage module using a more complex method than a standard breakpoint.

In a simple setup, you can define three transition triggers, where the last one triggers an action. In an advanced setup, the state machine can have four states (0-3). State 0 is the starting state, and state 3 is the state that triggers a breakpoint (the action state). This breakpoint can be designed either to stop execution, or to trigger the state storage module.

## REQUIREMENTS FOR USING THE SEQUENCER

The sequencer module is only available for the C-SPY FET Debugger driver and if you are using a device that supports the Enhanced Emulation Module at the required level.

---

## Using the sequencer

This section gives you step-by-step descriptions about how to use certain features of the sequencer module.

More specifically, you will get information about:

- Setting up the sequencer (simple setup)
- Setting up the sequencer (advanced setup)
- Using the sequencer to locate a problem.

### SETTING UP THE SEQUENCER (SIMPLE SETUP)

In a simple setup, you can define three transition triggers, where the last one triggers an action.

#### To define a simple sequencer setup:

- 1 Choose **Emulator>Sequencer Control** to open the Sequencer Control window.
- 2 Select the option **Enable Sequencer**.
- 3 Use the **Transition trigger** drop-down lists to define three breakpoints, where the last breakpoint should act as a transition trigger.

### SETTING UP THE SEQUENCER (ADVANCED SETUP)

In an advanced setup, the state machine can have four states (0-3). State 0 is the starting state, and state 3 is the state that triggers a breakpoint (the action state). This breakpoint can be designed either to stop execution, or to trigger the state storage module.

#### To define an advanced sequencer setup:

- 1 Choose **Emulator>Sequencer Control** to open the Sequencer Control window.
- 2 Select the option **Enable Sequencer**.
- 3 Click the **Advanced** button. This will let you define 4 states (0-3) with two transition triggers each (a and b).

From the eight available hardware breakpoints (0-7) of the device, breakpoint number 7 will be reserved for state 3. The **Transition trigger** drop-down lists let you define one breakpoint each, where the breakpoint should act as a transition trigger.

- 4 For each transition trigger, define which state should be the next state after the transition.

Use the following options:

**State Storage Trigger** Select a breakpoint from the drop-down list to move the state machine from one state to another. Note: to do this you must first define the required conditional breakpoints.

**Next state** Select a state to define which state should be the next state after the transition.

- 5 Select an action to determine the result of the final transition trigger. If you select the option **Break**, the execution will stop. If you select the option **State Storage Trigger**, the state storage module will be triggered.

## USING THE SEQUENCER TO LOCATE A PROBLEM

Consider this example:

```
void my_putchar(char c)
{
    ...
    /* Code suspected to be erroneous */
    ...
}

void my_function(void)
{
    ...
    my_putchar('a');
    ...
    my_putchar('x');
    ...
    my_putchar('@');
    ...
}
```

In this example, the customized `putchar` function `my_putchar` has for some reason a problem with special characters. To locate the problem, it might be useful to stop execution when the function is called, but only when it is called with one of the problematic characters as the argument.

### To locate the problem:

- 1 Set a hardware breakpoint on the statement `my_putchar('@');`.
- 2 Set another breakpoint on the suspected code within the function `my_putchar()`.

- 3 Define these breakpoints as transition triggers. Choose **Emulator>Sequencer Control** to open the Sequencer Control window. Select the option **Enable sequencer**.
- 4 In this simple example you will only need two transition triggers. Make sure the following options are selected:

Option	Setting
Transition trigger 0	The breakpoint which is set on the function call <code>my_putchar('@');</code>
Transition trigger 1	The breakpoint which is set on the suspected code within the function <code>my_putchar()</code>
Action	Break

Table 14: Sequencer settings - example

The transition trigger 1 depends on the transition trigger 0. This means that the execution will stop only when the function `my_putchar()` is called by the function call `my_putchar('@');`

Click **OK**.

- 5 Set up the state storage module. Choose **Emulator>State Storage Control** to open the State Storage Control window. Make sure the following options are selected:

Option	Setting
Enable state storage	Selected
Buffer wrap around	Selected
Storage action	Instruction fetch
Trigger action	None

Table 15: State Storage Control settings—example

Click **OK**.

- 6 Start the program execution. The state storage module will continuously store trace information. Execution stops when the function `my_putchar()` has been called by the function call `my_putchar('@');`
- 7 Choose **Emulator>State Storage Window** to open the **State Storage** window. You can now examine the stored trace information. For more information, see *State Storage window*, page 296.
- 8 When the sequencer is in state 3, the C-SPY breakpoint mechanism—which is used for all breakpoints, not only transition triggers—can be locked. Therefore, you should always end the session with one of these steps:
  - Disabling the sequencer module. This will restore all breakpoint actions.

- Resetting the state machine by clicking the **Reset States** button. The sequencer will still be active and trigger on the defined setup during the program execution.

## Reference information on the sequencer

This section gives reference information about the **Sequencer Control** window.

### Sequencer Control window

The Sequencer Control window is available from the **Emulator** menu.

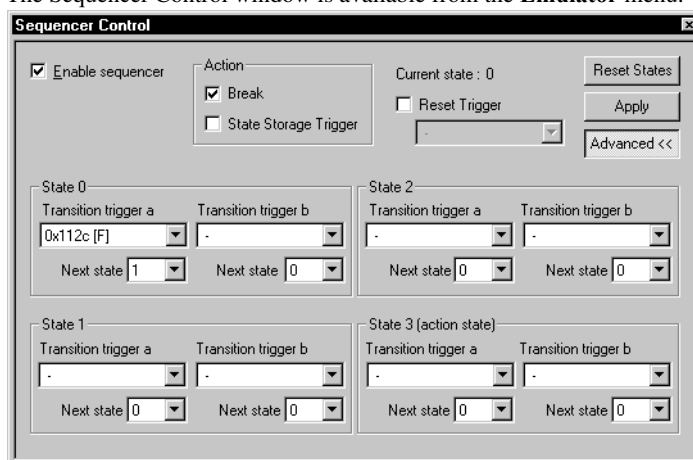

Use this window to break the execution or trigger the state storage module, using a more complex method than a standard breakpoint. The window is only available for devices that support the Enhanced Emulation Module at the required level.

For related information about state storage, see *State storage*, page 291.

#### Requirements

The C-SPY FET Debugger driver.

#### Enable Sequencer

Enables the sequencer.

#### Action

Controls the result of the final transition trigger:

**Break**

Stops the execution.

**State Storage Trigger**

Triggers to move the state machine from one state to another and activates the state storage module. Requires that you select a conditional breakpoint, that you have defined, from the **Transition trigger** drop-down list.

**Current state**

Displays the current state of the state machine.

**Reset Trigger**

Selects a trigger that will reset the state machine.

**Reset States**

Sets the state machine to state 0.

**Advanced**

Displays the advanced setup options. This will let you define 4 states (numbered 0–3) with two transition triggers each (a and b). For each transition trigger, you can define which state should be the next state after the transition.

**State 0–3**

Controls the transition triggers and the state that follows the transitions.

**Transition trigger a**

Selects a breakpoint to act as a transition trigger.

**Transition trigger b**

Selects a breakpoint to act as a transition trigger.

**Next state**

Select the next state after the transition.

For state 3—the final transition trigger—you must also define an **Action: Break** or **State Storage Trigger**.



# C-SPY macros

- Introduction to C-SPY macros
- Using C-SPY macros
- Reference information on the macro language
- Reference information on reserved setup macro function names
- Reference information on C-SPY system macros
- Graphical environment for macros

---

## Introduction to C-SPY macros

These topics are covered:

- Reasons for using C-SPY macros
- Briefly about using C-SPY macros
- Briefly about setup macro functions and files
- Briefly about the macro language

### REASONS FOR USING C-SPY MACROS

You can use C-SPY macros either by themselves or in conjunction with complex breakpoints and interrupt simulation to perform a wide variety of tasks. Some examples where macros can be useful:

- Automating the debug session, for instance with trace printouts, printing values of variables, and setting breakpoints.
- Hardware configuring, such as initializing hardware registers.
- Feeding your application with simulated data during runtime.
- Simulating peripheral devices, see the chapter *Interrupts*. This only applies if you are using the simulator driver.
- Developing small debug utility functions, for instance calculating the stack depth.

## BRIEFLY ABOUT USING C-SPY MACROS

To use C-SPY macros, you should:

- Write your macro variables and functions and collect them in one or several *macro files*
- Register your macros
- Execute your macros.

For registering and executing macros, there are several methods to choose between. Which method you choose depends on which level of interaction or automation you want, and depending on at which stage you want to register or execute your macro.

## BRIEFLY ABOUT SETUP MACRO FUNCTIONS AND FILES

There are some reserved *setup macro function names* that you can use for defining macro functions which will be called at specific times, such as:

- Once after communication with the target system has been established but before downloading the application software
- Once after your application software has been downloaded
- Each time the reset command is issued
- Once when the debug session ends.

To define a macro function to be called at a specific stage, you should define and register a macro function with one of the reserved names. For instance, if you want to clear a specific memory area before you load your application software, the macro setup function `execUserPreload` should be used. This function is also suitable if you want to initialize some CPU registers or memory-mapped peripheral units before you load your application software.

You should define these functions in a *setup macro file*, which you can load before C-SPY starts. Your macro functions will then be automatically registered each time you start C-SPY. This is convenient if you want to automate the initialization of C-SPY, or if you want to register multiple setup macros.

For more information about each setup macro function, see *Reference information on reserved setup macro function names*, page 317.

## BRIEFLY ABOUT THE MACRO LANGUAGE

The syntax of the macro language is very similar to the C language. There are:

- *Macro statements*, which are similar to C statements.
- *Macro functions*, which you can define with or without parameters and return values.

- Predefined built-in *system macros*, similar to C library functions, which perform useful tasks such as opening and closing files, setting breakpoints, and defining simulated interrupts.
- *Macro variables*, which can be global or local, and can be used in C-SPY expressions.
- *Macro strings*, which you can manipulate using predefined system macros.

For more information about the macro language components, see *Reference information on the macro language*, page 312.

### Example

Consider this example of a macro function which illustrates the various components of the macro language:

```
__var oldVal;
CheckLatest(val)
{
    if (oldVal != val)
    {
        __message "Message: Changed from ", oldVal, " to ", val, "\n";
        oldVal = val;
    }
}
```

**Note:** Reserved macro words begin with double underscores to prevent name conflicts.

---

## Using C-SPY macros

These tasks are covered:

- Registering C-SPY macros—an overview
- Executing C-SPY macros—an overview
- Registering and executing using setup macros and setup files
- Executing macros using Quick Watch
- Executing a macro by connecting it to a breakpoint
- Aborting a C-SPY macro

For more examples using C-SPY macros, see:

- The tutorial about simulating an interrupt, which you can find in the Information Center
- *Initializing target hardware before C-SPY starts*, page 49.

## REGISTERING C-SPY MACROS—AN OVERVIEW

C-SPY must know that you intend to use your defined macro functions, and thus you must *register* your macros. There are various ways to register macro functions:

- You can register macro functions during the C-SPY startup sequence, see *Registering and executing using setup macros and setup files*, page 309.
- You can register macros interactively in the **Macro Registration** window, see *Macro Registration window*, page 357. Registered macros appear in the **Debugger Macros** window, see *Debugger Macros window*, page 359.
- You can register a file containing macro function definitions, using the system macro `__registerMacroFile`. This means that you can dynamically select which macro files to register, depending on the runtime conditions. Using the system macro also lets you register multiple files at the same moment. For information about the system macro, see *\_\_registerMacroFile*, page 338.

Which method you choose depends on which level of interaction or automation you want, and depending on at which stage you want to register your macro.

## EXECUTING C-SPY MACROS—AN OVERVIEW

There are various ways to execute macro functions:

- You can execute macro functions during the C-SPY startup sequence and at other predefined stages during the debug session by defining setup macro functions in a setup macro file, see *Registering and executing using setup macros and setup files*, page 309.
- The **Quick Watch** window lets you evaluate expressions, and can thus be used for executing macro functions. For an example, see *Executing macros using Quick Watch*, page 309.
- The **Macro Quicklaunch** window is similar to the **Quick Watch** window, but is more specified on designed for C-SPY macros. See *Macro Quicklaunch window*, page 361.
- A macro can be connected to a breakpoint; when the breakpoint is triggered the macro is executed. For an example, see *Executing a macro by connecting it to a breakpoint*, page 310.

Which method you choose depends on which level of interaction or automation you want, and depending on at which stage you want to execute your macro.

## REGISTERING AND EXECUTING USING SETUP MACROS AND SETUP FILES

It can be convenient to register a macro file during the C-SPY startup sequence. To do this, specify a macro file which you load before starting the debug session. Your macro functions will be automatically registered each time you start the debugger.

If you use the reserved setup macro function names to define the macro functions, you can define exactly at which stage you want the macro function to be executed.

### To define a setup macro function and load it during C-SPY startup:

- 1 Create a new text file where you can define your macro function.

For example:

```
execUserSetup()
{
    ...
    __registerMacroFile("MyMacroUtils.mac");
    __registerMacroFile("MyDeviceSimulation.mac");
}
```

This macro function registers the additional macro files `MyMacroUtils.mac` and `MyDeviceSimulation.mac`. Because the macro function is defined with the function name `execUserSetup`, it will be executed directly after your application has been downloaded.

- 2 Save the file using the filename extension `mac`.
- 3 Before you start C-SPY, choose **Project>Options>Debugger>Setup**. Select **Use Setup file** and choose the macro file you just created.

The macros will now be registered during the C-SPY startup sequence.

## EXECUTING MACROS USING QUICK WATCH

The **Quick Watch** window lets you dynamically choose when to execute a macro function.

- 1 Consider this simple macro function that checks the status of a timer enable bit:

```
TimerStatus()
{
    if ((TimerStatreg & 0x01) != 0) /* Checks the status of reg */
        return "Timer enabled"; /* C-SPY macro string used */
    else
        return "Timer disabled"; /* C-SPY macro string used */
}
```

- 2 Save the macro function using the filename extension `mac`.
- 3 To load the macro file, choose **View>Macros>Macro Registration**. The **Macro Registration** window is displayed. Click **Add** and locate the file using the file browser. The macro file appears in the list of macros in the **Macro Registration** window.
- 4 Select the macro you want to register and your macro will appear in the **Debugger Macros** window.
- 5 Choose **View>Quick Watch** to open the **Quick Watch** window, type the macro call `TimerStatus()` in the text field and press Return,

Alternatively, in the macro file editor window, select the macro function name `TimerStatus()`. Right-click, and choose **Quick Watch** from the context menu that appears.

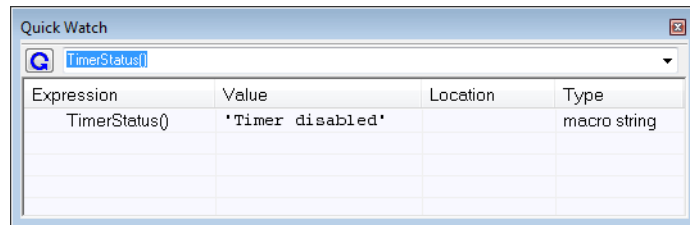

The macro will automatically be displayed in the **Quick Watch** window.

For more information, see *Quick Watch window*, page 97.

## EXECUTING A MACRO BY CONNECTING IT TO A BREAKPOINT

You can connect a macro to a breakpoint. The macro will then be executed when the breakpoint is triggered. The advantage is that you can stop the execution at locations of particular interest and perform specific actions there.



For instance, you can easily produce log reports containing information such as how the values of variables, symbols, or registers change. To do this you might set a breakpoint on a suspicious location and connect a log macro to the breakpoint. After the execution you can study how the values of the registers have changed.

### To create a log macro and connect it to a breakpoint:

- 1 Assume this skeleton of a C function in your application source code:

```
int fact(int x)
{
    ...
}
```

- 2 Create a simple log macro function like this example:

```
logfact ()
{
  __message "fact (" ,x, " )";
}
```

The `__message` statement will log messages to the Log window.

Save the macro function in a macro file, with the filename extension `mac`.

- 3 To register the macro, choose **View>Macros>Macro Registration** to open the **Macro Registration** window and add your macro file to the list. Select the file to register it. Your macro function will appear in the **Debugger Macros** window.
- 4 To set a code breakpoint, click the **Toggle Breakpoint** button on the first statement within the function `fact` in your application source code. Choose **View>Breakpoints** to open the **Breakpoints** window. Select your breakpoint in the list of breakpoints and choose the **Edit** command from the context menu.
- 5 To connect the log macro function to the breakpoint, type the name of the macro function, `logfact ()`, in the **Action** field and click **Apply**. Close the dialog box.
- 6 Execute your application source code. When the breakpoint is triggered, the macro function will be executed. You can see the result in the **Log** window.
  - Note that the expression in the **Action** field is evaluated only when the breakpoint causes the execution to really stop. If you want to log a value and then automatically continue execution, you can either:
    - Use a **Log** breakpoint, see *Log breakpoints dialog box*, page 119
    - Use the **Condition** field instead of the **Action** field. For an example, see *Performing a task and continuing execution*, page 113.
- 7 You can easily enhance the log macro function by, for instance, using the `__fmessage` statement instead, which will print the log information to a file. For information about the `__fmessage` statement, see *Formatted output*, page 315.

For an example where a serial port input buffer is simulated using the method of connecting a macro to a breakpoint, see the tutorial *Simulating an interrupt* in the Information Center.

## ABORTING A C-SPY MACRO

### To abort a C-SPY macro:

- 1 Press **Ctrl+Shift+.** (period) for a short while.
- 2 A message that says that the macro has terminated is displayed in the **Debug Log** window.

This method can be used if you suspect that something is wrong with the execution, for example because it seems not to terminate in a reasonable time.

---

## Reference information on the macro language

Reference information about:

- *Macro functions*, page 312
- *Macro variables*, page 312
- *Macro parameters*, page 313
- *Macro strings*, page 313
- *Macro statements*, page 314
- *Formatted output*, page 315.

### MACRO FUNCTIONS

C-SPY macro functions consist of C-SPY variable definitions and macro statements which are executed when the macro is called. An unlimited number of parameters can be passed to a macro function, and macro functions can return a value on exit.

A C-SPY macro has this form:

```
macroName (parameterList)
{
    macroBody
}
```

where *parameterList* is a list of macro parameters separated by commas, and *macroBody* is any series of C-SPY variable definitions and C-SPY statements.

Type checking is neither performed on the values passed to the macro functions nor on the return value.

### MACRO VARIABLES

A macro variable is a variable defined and allocated outside your application. It can then be used in a C-SPY expression, or you can assign application data—values of the variables in your application—to it. For more information about C-SPY expressions, see *C-SPY expressions*, page 80.

The syntax for defining one or more macro variables is:

```
__var nameList;
```

where *nameList* is a list of C-SPY variable names separated by commas.



A macro variable defined outside a macro body has global scope, and it exists throughout the whole debugging session. A macro variable defined within a macro body is created when its definition is executed and destroyed on return from the macro.

By default, macro variables are treated as signed integers and initialized to 0. When a C-SPY variable is assigned a value in an expression, it also acquires the type of that expression. For example:

Expression	What it means
<code>myvar = 3.5;</code>	<code>myvar</code> is now type <code>double</code> , value <code>3.5</code> .
<code>myvar = (int*)i;</code>	<code>myvar</code> is now type <code>pointer to int</code> , and the value is the same as <code>i</code> .

Table 16: Examples of C-SPY macro variables

In case of a name conflict between a C symbol and a C-SPY macro variable, C-SPY macro variables have a higher precedence than C variables. Note that macro variables are allocated on the debugger host and do not affect your application.

## MACRO PARAMETERS

A macro parameter is intended for parameterization of device support. The named parameter will behave as a normal C-SPY macro variable with these differences:

- The parameter definition can have an initializer
- Values of a parameters can be set through options (either in the IDE or in `cs spybat`).
- A value set from an option will take precedence over a value set by an initializer
- A parameter must have an initializer, be set through an option, or both. Otherwise, it has an undefined value, and accessing it will cause a runtime error.

The syntax for defining one or more macro parameters is:

```
__param param[ = value, ...;]
```

Use the command line option `--macro_param` to specify a value to a parameter, see `--macro_param`, page 380.

## MACRO STRINGS

In addition to C types, macro variables can hold values of *macro strings*. Note that macro strings differ from C language strings.

When you write a string literal, such as `"Hello!"`, in a C-SPY expression, the value is a macro string. It is not a C-style character pointer `char*`, because `char*` must point to a sequence of characters in target memory and C-SPY cannot expect any string literal to actually exist in target memory.

You can manipulate a macro string using a few built-in macro functions, for example `__strFind` or `__subString`. The result can be a new macro string. You can

concatenate macro strings using the + operator, for example `str + "tail"`. You can also access individual characters using subscription, for example `str[3]`. You can get the length of a string using `sizeof(str)`. Note that a macro string is not NULL-terminated.

The macro function `__toString` is used for converting from a NULL-terminated C string in your application (`char*` or `char[]`) to a macro string. For example, assume this definition of a C string in your application:

```
char const *cstr = "Hello";
```

Then examine these macro examples:

```
__var str;          /* A macro variable */
str = cstr          /* str is now just a pointer to char */
sizeof str         /* same as sizeof (char*), typically 2 or 4 */
str = __toString(cstr,512) /* str is now a macro string */
sizeof str        /* 5, the length of the string */
str[1]            /* 101, the ASCII code for 'e' */
str += " World!" /* str is now "Hello World!" */
```

See also *Formatted output*, page 315.

## MACRO STATEMENTS

Statements are expected to behave in the same way as the corresponding C statements would do. The following C-SPY macro statements are accepted:

### Expressions

```
expression;
```

For more information about C-SPY expressions, see *C-SPY expressions*, page 80.

### Conditional statements

```
if (expression)
    statement
```

```
if (expression)
    statement
else
    statement
```

## Loop statements

```
for (init_expression; cond_expression; update_expression)
    statement
```

```
while (expression)
    statement
```

```
do
    statement
while (expression);
```

## Return statements

```
return;
```

```
return expression;
```

If the return value is not explicitly set, signed int 0 is returned by default.

## Blocks

Statements can be grouped in blocks.

```
{
    statement1
    statement2
    .
    .
    statementN
}
```

## FORMATTED OUTPUT

C-SPY provides various methods for producing formatted output:

<code>__message <i>argList</i>;</code>	Prints the output to the <b>Debug Log</b> window.
<code>__fmessage <i>file</i>, <i>argList</i>;</code>	Prints the output to the designated file.
<code>__smessage <i>argList</i>;</code>	Returns a string containing the formatted output.

where *argList* is a comma-separated list of C-SPY expressions or strings, and *file* is the result of the `__openFile` system macro, see `__openFile`, page 332.

To produce messages in the **Debug Log** window:

```
var1 = 42;
var2 = 37;
__message "This line prints the values ", var1, " and ", var2,
" in the Log window.";
```

This produces this message in the Log window:

This line prints the values 42 and 37 in the Log window.

To write the output to a designated file:

```
__fmessage myfile, "Result is ", res, "!\n";
```

To produce strings:

```
myMacroVar = __smessage 42, " is the answer.";
myMacroVar now contains the string "42 is the answer.".
```

### Specifying display format of arguments

To override the default display format of a scalar argument (number or pointer) in *argList*, suffix it with a `:` followed by a format specifier. Available specifiers are:

<code>%b</code>	for binary scalar arguments
<code>%o</code>	for octal scalar arguments
<code>%d</code>	for decimal scalar arguments
<code>%x</code>	for hexadecimal scalar arguments
<code>%c</code>	for character scalar arguments

These match the formats available in the **Watch** and **Locals** windows, but number prefixes and quotes around strings and characters are not printed. Another example:

```
__message "The character '", cvar:%c, "' has the decimal value
", cvar;
```

Depending on the value of the variables, this produces this message:

The character 'A' has the decimal value 65

**Note:** A character enclosed in single quotes (a character literal) is an integer constant and is not automatically formatted as a character. For example:

```
__message 'A', " is the numeric value of the character ",
'A':%c;
```

would produce:

```
65 is the numeric value of the character A
```

**Note:** The default format for certain types is primarily designed to be useful in the **Watch** window and other related windows. For example, a value of type `char` is formatted as `'A' (0x41)`, while a pointer to a character (potentially a C string) is formatted as `0x8102 "Hello"`, where the string part shows the beginning of the string (currently up to 60 characters).

When printing a value of type `char*`, use the `%x` format specifier to print just the pointer value in hexadecimal notation, or use the system macro `__toString` to get the full string value.

---

## Reference information on reserved setup macro function names

There are reserved setup macro function names that you can use for defining your setup macro functions. By using these reserved names, your function will be executed at defined stages during execution. For more information, see *Briefly about setup macro functions and files*, page 306.

Reference information about:

- `execUserPreload`
- `execUserExecutionStarted`
- `execUserExecutionStopped`
- `execUserSetup`
- `execUserPreReset`
- `execUserReset`
- `execUserExit`

### **execUserPreload**

Syntax	<code>execUserPreload</code>
For use with	All C-SPY drivers.
Description	Called after communication with the target system is established but before downloading the target application.  Implement this macro to initialize memory locations and/or registers which are vital for loading data properly.

## execUserExecutionStarted

Syntax	<code>execUserExecutionStarted</code>
For use with	All C-SPY drivers.
Description	Called when the debugger is about to start or resume execution. The macro is not called when performing a one-instruction assembler step, in other words, Step or Step Into in the <b>Disassembly</b> window.

## execUserExecutionStopped

Syntax	<code>execUserExecutionStopped</code>
For use with	All C-SPY drivers.
Description	Called when the debugger has stopped execution. The macro is not called when performing a one-instruction assembler step, in other words, Step or Step Into in the <b>Disassembly</b> window.

## execUserSetup

Syntax	<code>execUserSetup</code>
For use with	All C-SPY drivers.
Description	Called once after the target application is downloaded. Implement this macro to set up the memory map, breakpoints, interrupts, register macro files, etc.



If you define interrupts or breakpoints in a macro file that is executed at system start (using `execUserSetup`) we strongly recommend that you also make sure that they are removed at system shutdown (using `execUserExit`). An example is available in `SetupSimple.mac`, see the tutorials in the Information Center.

The reason for this is that the simulator saves interrupt settings between sessions and if they are not removed they will get duplicated every time `execUserSetup` is executed again. This seriously affects the execution speed.

## execUserPreReset

Syntax	<code>execUserPreReset</code>
For use with	All C-SPY drivers.
Description	Called each time just before the reset command is issued. Implement this macro to set up any required device state.

## execUserReset

Syntax	<code>execUserReset</code>
For use with	All C-SPY drivers.
Description	Called each time just after the reset command is issued. Implement this macro to set up and restore data.

## execUserExit

Syntax	<code>execUserExit</code>
For use with	All C-SPY drivers.
Description	Called once when the debug session ends. Implement this macro to save status data etc.

---

## Reference information on C-SPY system macros

This section gives reference information about each of the C-SPY system macros.

This table summarizes the pre-defined system macros:

Macro	Description
<code>__abortLaunch</code>	Aborts the launch of the debugger
<code>__cancelAllInterrupts</code>	Cancels all ordered interrupts
<code>__cancelInterrupt</code>	Cancels an interrupt
<code>__clearBreak</code>	Clears a breakpoint

*Table 17: Summary of system macros*

Macro	Description
<code>__closeFile</code>	Closes a file that was opened by <code>__openFile</code>
<code>__delay</code>	Delays execution
<code>__disableInterrupts</code>	Disables generation of interrupts
<code>__driverType</code>	Verifies the driver type
<code>__enableInterrupts</code>	Enables generation of interrupts
<code>__evaluate</code>	Interprets the input string as an expression and evaluates it.
<code>__fillMemory8</code>	Fills a specified memory area with a byte value.
<code>__fillMemory16</code>	Fills a specified memory area with a 2-byte value.
<code>__fillMemory32</code>	Fills a specified memory area with a 4-byte value.
<code>__isBatchMode</code>	Checks if C-SPY is running in batch mode or not.
<code>__loadImage</code>	Loads an image.
<code>__memoryRestore</code>	Restores the contents of a file to a specified memory zone
<code>__memorySave</code>	Saves the contents of a specified memory area to a file
<code>__messageBoxYesCancel</code>	Displays a Yes/Cancel dialog box for user interaction
<code>__messageBoxYesNo</code>	Displays a Yes/No dialog box for user interaction
<code>__openFile</code>	Opens a file for I/O operations
<code>__orderInterrupt</code>	Generates an interrupt
<code>__popSimulatorInterruptExecutingStack</code>	Informs the interrupt simulation system that an interrupt handler has finished executing
<code>__readFile</code>	Reads from the specified file
<code>__readFileByte</code>	Reads one byte from the specified file
<code>__readMemory8,</code> <code>__readMemoryByte</code>	Reads one byte from the specified memory location
<code>__readMemory16</code>	Reads two bytes from the specified memory location
<code>__readMemory32</code>	Reads four bytes from the specified memory location
<code>__registerMacroFile</code>	Registers macros from the specified file
<code>__resetFile</code>	Rewinds a file opened by <code>__openFile</code>
<code>__setAdvancedTriggerBreak</code>	Sets an advanced trigger breakpoint
<code>__setCodeBreak</code>	Sets a code breakpoint
<code>__setConditionalBreak</code>	Sets a conditional breakpoint

Table 17: Summary of system macros



Macro	Description
<code>__setDataBreak</code>	Sets a data breakpoint
<code>__setDataLogBreak</code>	Sets a data log breakpoint
<code>__setLogBreak</code>	Sets a log breakpoint
<code>__setRangeBreak</code>	Sets a range breakpoint
<code>__setSimBreak</code>	Sets a simulation breakpoint
<code>__setTraceStartBreak</code>	Sets a trace start breakpoint
<code>__setTraceStopBreak</code>	Sets a trace stop breakpoint
<code>__sourcePosition</code>	Returns the file name and source location if the current execution location corresponds to a source location
<code>__strFind</code>	Searches a given string for the occurrence of another string
<code>__subString</code>	Extracts a substring from another string
<code>__targetDebuggerVersion</code>	Returns the version of the target debugger
<code>__toLowerCase</code>	Returns a copy of the parameter string where all the characters have been converted to lower case
<code>__toString</code>	Prints strings
<code>__toUpperCase</code>	Returns a copy of the parameter string where all the characters have been converted to upper case
<code>__unloadImage</code>	Unloads a debug image
<code>__writeFile</code>	Writes to the specified file
<code>__writeFileByte</code>	Writes one byte to the specified file
<code>__writeMemory8,</code> <code>__writeMemoryByte</code>	Writes one byte to the specified memory location
<code>__writeMemory16</code>	Writes a two-byte word to the specified memory location
<code>__writeMemory32</code>	Writes a four-byte word to the specified memory location

Table 17: Summary of system macros

## `__abortLaunch`

Syntax `__abortLaunch(message)`

Parameters *message*

A string that is printed as an error message when the macro executes.

Return value	None.
For use with	All C-SPY drivers.
Description	This macro can be used for aborting a debugger launch, for example if another macro sees that something goes wrong during initialization and cannot perform a proper setup.  This is an emergency exit, not a recommended way to end a debug session like the C library function <code>abort()</code> .
Example	<pre>if (!__messageBoxYesCancel("Do you want to mass erase to unlock                            the device?", "Unlocking device")) { __abortLaunch("Unlock canceled. Debug session cannot                 continue."); }</pre>

## **\_\_cancelAllInterrupts**

Syntax	<code>__cancelAllInterrupts()</code>
Return value	<code>int 0</code>
For use with	The C-SPY Simulator.
Description	Cancels all ordered interrupts.

## **\_\_cancelInterrupt**

Syntax	<code>__cancelInterrupt(<i>interrupt_id</i>)</code>
Parameters	<i>interrupt_id</i> The value returned by the corresponding <code>__orderInterrupt</code> macro call (unsigned long).
Return value	

Result	Value
Successful	<code>int 0</code>
Unsuccessful	Non-zero error number

Table 18: `__cancelInterrupt` return values

For use with	The C-SPY Simulator.
Description	Cancels the specified interrupt.

## \_\_clearBreak

Syntax	<code>__clearBreak(<i>break_id</i>)</code>
Parameters	<i>break_id</i> The value returned by any of the set breakpoint macros.
Return value	<code>int 0</code>
For use with	All C-SPY drivers.
Description	Clears a user-defined breakpoint.
See also	<i>Breakpoints</i> , page 103.

## \_\_closeFile

Syntax	<code>__closeFile(<i>fileHandle</i>)</code>
Parameters	<i>fileHandle</i> A macro variable used as filehandle by the <code>__openFile</code> macro.
Return value	<code>int 0</code>
For use with	All C-SPY drivers.
Description	Closes a file previously opened by <code>__openFile</code> .

## \_\_delay

Syntax	<code>__delay(<i>value</i>)</code>
Parameters	<i>value</i> The number of milliseconds to delay execution.
Return value	<code>int 0</code>
For use with	All C-SPY drivers.
Description	Delays execution the specified number of milliseconds.

## **\_\_disableInterrupts**

Syntax `__disableInterrupts()`

Return value

Result	Value
Successful	int 0
Unsuccessful	Non-zero error number

Table 19: `__disableInterrupts` return values

For use with The C-SPY Simulator.

Description Disables the generation of interrupts.

## **\_\_driverType**

Syntax `__driverType(driver_id)`

Parameters

`driver_id`

A string corresponding to the driver you want to check for. Choose one of these:

"sim" corresponds to the simulator driver.

"fet" corresponds to the C-SPY FET Debugger driver.

Return value

Result	Value
Successful	1
Unsuccessful	0

Table 20: `__driverType` return values

For use with All C-SPY drivers

Description Checks to see if the current C-SPY driver is identical to the driver type of the `driver_id` parameter.

Example

`__driverType("sim")`

If the simulator is the current driver, the value 1 is returned. Otherwise 0 is returned.

## \_\_enableInterrupts

Syntax `__enableInterrupts()`

Return value

Result	Value
Successful	int 0
Unsuccessful	Non-zero error number

Table 21: `__enableInterrupts` return values

For use with The C-SPY Simulator.

Description Enables the generation of interrupts.

## \_\_evaluate

Syntax `__evaluate(string, valuePtr)`

Parameters

*string*

Expression string.

*valuePtr*

Pointer to a macro variable storing the result.

Return value

Result	Value
Successful	int 0
Unsuccessful	int 1

Table 22: `__evaluate` return values

For use with All C-SPY drivers.

Description This macro interprets the input string as an expression and evaluates it. The result is stored in a variable pointed to by *valuePtr*.

Example

This example assumes that the variable `i` is defined and has the value 5:

```
__evaluate("i + 3", &myVar)
```

The macro variable `myVar` is assigned the value 8.

**\_\_fillMemory8**

Syntax	<code>__fillMemory8(<i>value</i>, <i>address</i>, <i>zone</i>, <i>length</i>, <i>format</i>)</code>								
Parameters	<p><i>value</i> An integer that specifies the value.</p> <p><i>address</i> An integer that specifies the memory start address.</p> <p><i>zone</i> A string that specifies the memory zone, see <i>C-SPY memory zones</i>, page 138.</p> <p><i>length</i> An integer that specifies how many bytes are affected.</p> <p><i>format</i> One of these alternatives:</p> <table> <tr> <td>Copy</td> <td><i>value</i> will be copied to the specified memory area.</td> </tr> <tr> <td>AND</td> <td>An AND operation will be performed between <i>value</i> and the existing contents of memory before writing the result to memory.</td> </tr> <tr> <td>OR</td> <td>An OR operation will be performed between <i>value</i> and the existing contents of memory before writing the result to memory.</td> </tr> <tr> <td>XOR</td> <td>An XOR operation will be performed between <i>value</i> and the existing contents of memory before writing the result to memory.</td> </tr> </table>	Copy	<i>value</i> will be copied to the specified memory area.	AND	An AND operation will be performed between <i>value</i> and the existing contents of memory before writing the result to memory.	OR	An OR operation will be performed between <i>value</i> and the existing contents of memory before writing the result to memory.	XOR	An XOR operation will be performed between <i>value</i> and the existing contents of memory before writing the result to memory.
Copy	<i>value</i> will be copied to the specified memory area.								
AND	An AND operation will be performed between <i>value</i> and the existing contents of memory before writing the result to memory.								
OR	An OR operation will be performed between <i>value</i> and the existing contents of memory before writing the result to memory.								
XOR	An XOR operation will be performed between <i>value</i> and the existing contents of memory before writing the result to memory.								
Return value	<code>int 0</code>								
For use with	All C-SPY drivers.								
Description	Fills a specified memory area with a byte value.								
Example	<code>__fillMemory8(0x80, 0x700, "Memory", 0x10, "OR");</code>								

**\_\_fillMemory16**

Syntax	<code>__fillMemory16(<i>value</i>, <i>address</i>, <i>zone</i>, <i>length</i>, <i>format</i>)</code>
Parameters	<p><i>value</i> An integer that specifies the value.</p>

	<i>address</i>	An integer that specifies the memory start address.
	<i>zone</i>	A string that specifies the memory zone, see <i>C-SPY memory zones</i> , page 138.
	<i>length</i>	An integer that defines how many 2-byte entities to be affected.
	<i>format</i>	One of these alternatives: <ul style="list-style-type: none"> <li>Copy      <i>value</i> will be copied to the specified memory area.</li> <li>AND        An AND operation will be performed between <i>value</i> and the existing contents of memory before writing the result to memory.</li> <li>OR         An OR operation will be performed between <i>value</i> and the existing contents of memory before writing the result to memory.</li> <li>XOR        An XOR operation will be performed between <i>value</i> and the existing contents of memory before writing the result to memory.</li> </ul>
Return value	int 0	
For use with	All C-SPY drivers.	
Description	Fills a specified memory area with a 2-byte value.	
Example	<code>__fillMemory16(0xCDCD, 0x7000, "Memory", 0x200, "Copy");</code>	

## **\_\_fillMemory32**

Syntax	<code>__fillMemory32(<i>value</i>, <i>address</i>, <i>zone</i>, <i>length</i>, <i>format</i>)</code>
Parameters	<p><i>value</i></p> <p>An integer that specifies the value.</p> <p><i>address</i></p> <p>An integer that specifies the memory start address.</p> <p><i>zone</i></p> <p>A string that specifies the memory zone, see <i>C-SPY memory zones</i>, page 138.</p>

*length*

An integer that defines how many 4-byte entities to be affected.

*format*

One of these alternatives:

Copy	<i>value</i> will be copied to the specified memory area.
AND	An AND operation will be performed between <i>value</i> and the existing contents of memory before writing the result to memory.
OR	An OR operation will be performed between <i>value</i> and the existing contents of memory before writing the result to memory.
XOR	An XOR operation will be performed between <i>value</i> and the existing contents of memory before writing the result to memory.

Return value	int 0
For use with	All C-SPY drivers.
Description	Fills a specified memory area with a 4-byte value.
Example	<code>__fillMemory32(0x0000FFFF, 0x4000, "Memory", 0x1000, "XOR");</code>

## **\_\_isBatchMode**

Syntax	<code>__isBatchMode()</code>
--------	------------------------------

Return value

Result	Value
True	int 1
False	int 0

Table 23: *\_\_isBatchMode* return values

For use with	All C-SPY drivers.
--------------	--------------------

Description	This macro returns True if the debugger is running in batch mode, otherwise it returns False.
-------------	---



## \_\_loadImage

### Syntax

```
__loadImage(path, offset, debugInfoOnly)
```

### Parameters

*path*

A string that identifies the path to the image to download. The path must either be absolute or use argument variables. For information about argument variables, see the *IDE Project Management and Building Guide*.

*offset*

An integer that identifies the offset to the destination address for the downloaded image.

*debugInfoOnly*

A non-zero integer value if no code or data should be downloaded to the target system, which means that C-SPY will only read the debug information from the debug file. Or, 0 (zero) for download.

### Return value

Value	Result
Non-zero integer number	A unique module identification.
int 0	Loading failed.

Table 24: \_\_loadImage return values

### For use with

All C-SPY drivers.

### Description

Loads an image (debug file).

### Example 1

Your system consists of a ROM library and an application. The application is your active project, but you have a debug file corresponding to the library. In this case you can add this macro call in the `execUserSetup` macro in a C-SPY macro file, which you associate with your project:

```
__loadImage("ROMfile", 0x8000, 1);
```

This macro call loads the debug information for the ROM library `ROMfile` without downloading its contents (because it is presumably already in ROM). Then you can debug your application together with the library.

### Example 2

Your system consists of a ROM library and an application, but your main concern is the library. The library needs to be programmed into flash memory before a debug session. While you are developing the library, the library project must be the active project in the

IDE. In this case you can add this macro call in the `execUserSetup` macro in a C-SPY macro file, which you associate with your project:

```
__loadImage("ApplicationFile", 0x8000, 0);
```

The macro call loads the debug information for the application and downloads its contents (presumably into RAM). Then you can debug your library together with the application.

See also

*Images*, page 391 and *Loading multiple images*, page 47.

## \_\_memoryRestore

Syntax

```
__memoryRestore(zone, filename)
```

Parameters

*zone*

A string that specifies the memory zone, see *C-SPY memory zones*, page 138.

*filename*

A string that specifies the file to be read. The filename must include a path, which must either be absolute or use argument variables. For information about argument variables, see the *IDE Project Management and Building Guide*.

Return value

`int 0`

For use with

All C-SPY drivers.

Description

Reads the contents of a file and saves it to the specified memory zone.

Example

```
__memoryRestore("Memory", "c:\\temp\\saved_memory.hex");
```

See also

*Memory Restore dialog box*, page 150.

## \_\_memorySave

Syntax

```
__memorySave(start, stop, format, filename)
```

Parameters

*start*

A string that specifies the first location of the memory area to be saved.

*stop*

A string that specifies the last location of the memory area to be saved.

	<p><i>format</i></p> <p>A string that specifies the format to be used for the saved memory. Choose between:</p> <p>intel-extended</p> <p>motorola</p> <p>motorola-s19</p> <p>motorola-s28</p> <p>motorola-s37</p> <p>msp430-txt.</p> <p><i>filename</i></p> <p>A string that specifies the file to write to. The filename must include a path, which must either be absolute or use argument variables. For information about argument variables, see the <i>IDE Project Management and Building Guide</i>.</p>
Return value	int 0
For use with	All C-SPY drivers.
Description	Saves the contents of a specified memory area to a file.
Example	<pre>__memorySave("Memory:0x00", "Memory:0xFF", "intel-extended", "c:\\temp\\saved_memory.hex");</pre>
See also	<i>Memory Save dialog box</i> , page 149.

## \_\_messageBoxYesCancel

Syntax	<code>__messageBoxYesCancel(<i>message</i>, <i>caption</i>)</code>
Parameters	<p><i>message</i></p> <p>A message that will appear in the message box.</p> <p><i>caption</i></p> <p>The title that will appear in the message box.</p>

Return value

Result	Value
Yes	1
No	0

Table 25: *\_\_messageBoxYesCancel* return values

For use with

All C-SPY drivers.

Description

Displays a Yes/Cancel dialog box when called and returns the user input. Typically, this is useful for creating macros that require user interaction.

## **\_\_messageBoxYesNo**

Syntax

```
__messageBoxYesNo(message, caption)
```

Parameters

*message*

A message that will appear in the message box.

*caption*

The title that will appear in the message box.

Return value

Result	Value
Yes	1
No	0

Table 26: *\_\_messageBoxYesNo* return values

For use with

All C-SPY drivers.

Description

Displays a Yes/No dialog box when called and returns the user input. Typically, this is useful for creating macros that require user interaction.

## **\_\_openFile**

Syntax

```
__openFile(filename, access)
```

Parameters

*filename*

The file to be opened. The filename must include a path, which must either be absolute or use argument variables. For information about argument variables, see the *IDE Project Management and Building Guide*.

*access*

The access type (string).

These are mandatory but mutually exclusive:

"a" append, new data will be appended at the end of the open file

"r" read (by default in text mode; combine with b for binary mode: rb)

"w" write (by default in text mode; combine with b for binary mode: wb)

These are optional and mutually exclusive:

"b" binary, opens the file in binary mode

"t" ASCII text, opens the file in text mode

This access type is optional:

"+" together with r, w, or a; r+ or w+ is *read* and *write*, while a+ is *read* and *append*

## Return value

Result	Value
Successful	The file handle
Unsuccessful	An invalid file handle, which tests as False

Table 27: `__openFile` return values

## For use with

All C-SPY drivers.

## Description

Opens a file for I/O operations. The default base directory of this macro is where the currently open project file (\*.ewp) is located. The argument to `__openFile` can specify a location relative to this directory. In addition, you can use argument variables such as `$PROJ_DIR$` and `$TOOLKIT_DIR$` in the path argument.

## Example

```
__var myFileHandle;          /* The macro variable to contain */
                             /* the file handle */
myFileHandle = __openFile("$PROJ_DIR$\Debug\Exe\test.tst",
"r");
if (myFileHandle)
{
    /* successful opening */
}
```

## See also

For information about argument variables, see the *IDE Project Management and Building Guide*.

**\_\_orderInterrupt**

Syntax	<code>__orderInterrupt(<i>specification</i>, <i>first_activation</i>, <i>repeat_interval</i>, <i>variance</i>, <i>infinite_hold_time</i>, <i>hold_time</i>, <i>probability</i>)</code>
Parameters	<p><i>specification</i> The interrupt (string). The specification can either be the full specification used in the device description file (<code>ddf</code>) or only the name. In the latter case the interrupt system will automatically get the description from the device description file.</p> <p><i>first_activation</i> The first activation time in cycles (integer)</p> <p><i>repeat_interval</i> The periodicity in cycles (integer)</p> <p><i>variance</i> The timing variation range in percent (integer between 0 and 100)</p> <p><i>infinite_hold_time</i> 1 if infinite, otherwise 0.</p> <p><i>hold_time</i> The hold time (integer)</p> <p><i>probability</i> The probability in percent (integer between 0 and 100)</p>
Return value	The macro returns an interrupt identifier (unsigned long). If the syntax of <i>specification</i> is incorrect, it returns -1.
For use with	The C-SPY Simulator.
Description	Generates an interrupt.
Example	<p>This example generates a repeating interrupt using an infinite hold time first activated after 4000 cycles:</p> <pre>__orderInterrupt( "USART0RX_VECTOR", 4000, 2000, 0, 1, 0, 100 );</pre>

## \_\_popSimulatorInterruptExecutingStack

Syntax	<code>__popSimulatorInterruptExecutingStack(void)</code>
Return value	<code>int 0</code>
For use with	The C-SPY Simulator.
Description	<p>Informs the interrupt simulation system that an interrupt handler has finished executing, as if the normal instruction used for returning from an interrupt handler was executed.</p> <p>This is useful if you are using interrupts in such a way that the normal instruction for returning from an interrupt handler is not used, for example in an operating system with task-switching. In this case, the interrupt simulation system cannot automatically detect that the interrupt has finished executing.</p>
See also	<i>Simulating an interrupt in a multi-task system</i> , page 267.

## \_\_readFile

Syntax	<code>__readFile(fileHandle, valuePtr)</code>						
Parameters	<p><i>fileHandle</i> A macro variable used as filehandle by the <code>__openFile</code> macro.</p> <p><i>valuePtr</i> A pointer to a variable.</p>						
Return value	<table border="1"> <thead> <tr> <th>Result</th> <th>Value</th> </tr> </thead> <tbody> <tr> <td>Successful</td> <td>0</td> </tr> <tr> <td>Unsuccessful</td> <td>Non-zero error number</td> </tr> </tbody> </table> <p><i>Table 28: __readFile return values</i></p>	Result	Value	Successful	0	Unsuccessful	Non-zero error number
Result	Value						
Successful	0						
Unsuccessful	Non-zero error number						
For use with	All C-SPY drivers.						
Description	<p>Reads a sequence of hexadecimal digits from the given file and converts them to an <code>unsigned long</code> which is assigned to the <code>value</code> parameter, which should be a pointer to a macro variable.</p> <p>Only printable characters representing hexadecimal digits and white-space characters are accepted, no other characters are allowed.</p>						

## Example

```
__var number;
if (__readFile(myFileHandle, &number) == 0)
{
    // Do something with number
}
```

In this example, if the file pointed to by `myFileHandle` contains the ASCII characters 1234 abcd 90ef, consecutive reads will assign the values 0x1234 0xabcd 0x90ef to the variable `number`.

**\_\_readFileByte**

## Syntax

```
__readFileByte(fileHandle)
```

## Parameters

*fileHandle*

A macro variable used as filehandle by the `__openFile` macro.

## Return value

-1 upon error or end-of-file, otherwise a value between 0 and 255.

## For use with

All C-SPY drivers.

## Description

Reads one byte from a file.

## Example

```
__var byte;
while ( (byte = __readFileByte(myFileHandle)) != -1 )
{
    /* Do something with byte */
}
```

**\_\_readMemory8, \_\_readMemoryByte**

## Syntax

```
__readMemory8(address, zone)
__readMemoryByte(address, zone)
```

## Parameters

*address*

The memory address (integer).

*zone*

A string that specifies the memory zone, see *C-SPY memory zones*, page 138.

## Return value

The macro returns the value from memory.

## For use with

All C-SPY drivers.



Description Reads one byte from a given memory location.

Example `__readMemory8(0x0108, "Memory");`

## **\_\_readMemory16**

Syntax `__readMemory16(address, zone)`

Parameters

*address*

The memory address (integer).

*zone*

A string that specifies the memory zone, see *C-SPY memory zones*, page 138.

Return value The macro returns the value from memory.

For use with All C-SPY drivers.

Description Reads a two-byte word from a given memory location.

Example `__readMemory16(0x0108, "Memory");`

## **\_\_readMemory32**

Syntax `__readMemory32(address, zone)`

Parameters

*address*

The memory address (integer).

*zone*

A string that specifies the memory zone, see *C-SPY memory zones*, page 138.

Return value The macro returns the value from memory.

For use with All C-SPY drivers.

Description Reads a four-byte word from a given memory location.

Example `__readMemory32(0x0108, "Memory");`

**\_\_registerMacroFile**

Syntax	<code>__registerMacroFile(<i>filename</i>)</code>
Parameters	<i>filename</i> A file containing the macros to be registered (string). The filename must include a path, which must either be absolute or use argument variables. For information about argument variables, see the <i>IDE Project Management and Building Guide</i> .
Return value	int 0
For use with	All C-SPY drivers.
Description	Registers macros from a setup macro file. With this function you can register multiple macro files during C-SPY startup.
Example	<code>__registerMacroFile("c:\\testdir\\macro.mac");</code>
See also	<i>Using C-SPY macros</i> , page 307.

**\_\_resetFile**

Syntax	<code>__resetFile(<i>fileHandle</i>)</code>
Parameters	<i>fileHandle</i> A macro variable used as filehandle by the <code>__openFile</code> macro.
Return value	int 0
For use with	All C-SPY drivers.
Description	Rewinds a file previously opened by <code>__openFile</code> .

## \_\_setAdvancedTriggerBreak

Syntax	<code>__setAdvancedTriggerBreak(<i>type</i>, <i>condition</i>, <i>access</i>, <i>action</i>, <i>mask</i> <i>cond_value</i>)</code>
Parameters	All parameters are strings.
<i>type</i>	The breakpoint type; either "Address", "Data", or "Register".
<i>condition</i>	The breakpoint condition operator, either "==", ">=", "<=", or "!=".
<i>access</i>	The memory access type. Choose between: "Read" "Write" "ReadWrite" "Fetch" "FetchHold" "NoFetch" "NoFetchRead" "NoFetchNoDMA" "DMA" "NoDMA" "WriteNoDMA" "NoFetchReadNoDMA" "ReadNoDMA" "ReadDMA" "WroteDMA"
<i>action</i>	The action type: "Break", "Trigger", or "BreakTrigger".
<i>mask</i>	A 16-bit value that the breakpoint address or value will be masked with.
<i>cond_value</i>	An extra conditional data value.

Return value

Result	Value
Successful	An unsigned integer uniquely identifying the breakpoint. This value must be used to clear the breakpoint.
Unsuccessful	0

Table 29: `__setAdvancedTriggerBreak` return values

For use with

The C-SPY FET Debugger driver.

Description

Sets an advanced trigger breakpoint.

Example

```
__var brk;
brk = __setAdvancedTriggerBreak("Register", ">=", "Write",
                                "Trigger", "0x0000", "0x4000");
...
__clearBreak(brk);
```

See also

*Breakpoints*, page 103.

## `__setCodeBreak`

Syntax

```
__setCodeBreak(location, count, condition, cond_type, action)
```

Parameters

*location*

A string that defines the code location of the breakpoint, either a valid C-SPY expression whose value evaluates to a valid address, an absolute location, or a source location. For more information about the location types, see *Enter Location dialog box*, page 132.

*count*

The number of times that a breakpoint condition must be fulfilled before a break occurs (integer).

*condition*

The breakpoint condition (string).

*cond\_type*

The condition type; either "CHANGED" or "TRUE" (string).

*action*

An expression, typically a call to a macro, which is evaluated when the breakpoint is detected.

## Return value

Result	Value
Successful	An unsigned integer uniquely identifying the breakpoint. This value must be used to clear the breakpoint.
Unsuccessful	0

Table 30: `__setCodeBreak` return values

## For use with

All C-SPY drivers.

## Description

Sets a code breakpoint, that is, a breakpoint which is triggered just before the processor fetches an instruction at the specified location.

## Examples

```
__setCodeBreak("D:\\src\\prog.c}.12.9", 3, "d>16", "TRUE",
"ActionCode()");
```

This example sets a code breakpoint on the label `main` in your source:

```
__setCodeBreak("main", 0, "1", "TRUE", "");
```

## See also

*Breakpoints*, page 103.

**`__setConditionalBreak`**

## Syntax

```
__setConditionalBreak(location, type, operator, access, action,
mask, cond_value, cond_operator,
cond_access, cond_mask)
```

## Parameters

All parameters are strings.

*location*

The breakpoint location. Choose between:

A *source location* on the form "`{filename}.line.col`" (for example "`{D:\\src\\prog.c}.12.9`")

An *absolute location* on the form "`zone:hexaddress`" or simply "`hexaddress`" (for example "`Memory:0x42`")

An *expression* whose value designates a location (for example "`my_global_variable`").

A *register* (for example "`R10`")

*type*

The breakpoint type: "`Address`", "`Data`", or "`Register`".

*operator*

The breakpoint operator: "`==`", "`>=`", "`<=`", or "`!=`".

<i>access</i>	The memory access type: "Read", "Write", "ReadWrite", or "Fetch".
<i>action</i>	The action type: "Break", "Trigger", or "BreakTrigger".
<i>mask</i>	A 16-bit value that the breakpoint address or value will be masked with.
<i>cond_value</i>	An extra conditional data value.
<i>cond_operator</i>	The condition operator: "==", ">=", "<=", or "!=".
<i>cond_access</i>	The access type of the condition: "Read" or "Write".
<i>cond_mask</i>	The mask value of the condition.

## Return value

Result	Value
Successful	An unsigned integer uniquely identifying the breakpoint. This value must be used to clear the breakpoint.
Unsuccessful	0

Table 31: *\_\_setConditionalBreak* return values

## For use with

The C-SPY FET Debugger driver.

## Description

Sets a conditional breakpoint.

## Example

```

__var brk;
brk = __setConditionalBreak("R10", "Register", "0x5000", ">=",
    "Write", "Trigger", "0x0000", "0x4000", "<=", "Write",
    "0x00FF");
...
__clearBreak(brk);

```

## See also

*Breakpoints*, page 103.

## \_\_setDataBreak

### Syntax

```
__setDataBreak(location, count, condition, cond_type, access,
               action)
```

### Parameters

*location*

A string that defines the data location of the breakpoint, either a valid C-SPY expression whose value evaluates to a valid address or an absolute location. For more information about the location types, see *Enter Location dialog box*, page 132.

*count*

The number of times that a breakpoint condition must be fulfilled before a break occurs (integer).

*condition*

The breakpoint condition (string).

*cond\_type*

The condition type; either "CHANGED" or "TRUE" (string).

*access*

The memory access type: "R", for read, "W" for write, or "RW" for read/write.

*action*

An expression, typically a call to a macro, which is evaluated when the breakpoint is detected.

### Return value

Result	Value
Successful	An unsigned integer uniquely identifying the breakpoint. This value must be used to clear the breakpoint.
Unsuccessful	0

Table 32: \_\_setDataBreak return values

### For use with

The C-SPY Simulator.

### Description

Sets a data breakpoint, that is, a breakpoint which is triggered directly after the processor has read or written data at the specified location.

### Example

```
__var brk;
brk = __setDataBreak("Memory:0x4710", 3, "d>6", "TRUE",
                    "W", "ActionData()");
...
__clearBreak(brk);
```

See also *Breakpoints*, page 103.

## **\_\_setDataLogBreak**

Syntax

```
__setDataLogBreak(variable, access)
```

Parameters

*variable*

A string that defines the variable the breakpoint is set on, a variable of integer type with static storage duration. The microcontroller must also be able to access the variable with a single-instruction memory access, which means that you can only set data log breakpoints on 8-bit variables.

*access*

The memory access type: "R", for read, "W" for write, or "RW" for read/write.

Return value

Result	Value
Successful	An unsigned integer uniquely identifying the breakpoint. This value must be used to clear the breakpoint.
Unsuccessful	0

Table 33: *\_\_setDataLogBreak* return values

For use with

The C-SPY Simulator.

Description

Sets a data log breakpoint, that is, a breakpoint which is triggered when a specified variable is accessed. Note that a data log breakpoint does not stop the execution, it just generates a data log.

Example

```
__var brk;
brk = __setDataLogBreak("MyVar", "R");
...
__clearBreak(brk);
```

See also

*Breakpoints*, page 103 and *Getting started using data logging*, page 196.



## \_\_setLogBreak

### Syntax

```
__setLogBreak(location, message, msg_type, condition,
              cond_type)
```

### Parameters

*location*

A string that defines the code location of the breakpoint, either a valid C-SPY expression whose value evaluates to a valid address, an absolute location, or a source location. For more information about the location types, see *Enter Location dialog box*, page 132.

*message*

The message text.

*msg\_type*

The message type; choose between:

TEXT, the message is written word for word.

ARGS, the message is interpreted as a comma-separated list of C-SPY expressions or strings.

*condition*

The breakpoint condition (string).

*cond\_type*

The condition type; either "CHANGED" or "TRUE" (string).

### Return value

Result	Value
Successful	An unsigned integer uniquely identifying the breakpoint. The same value must be used when you want to clear the breakpoint.
Unsuccessful	0

Table 34: \_\_setLogBreak return values

### For use with

All C-SPY drivers.

### Description

Sets a log breakpoint, that is, a breakpoint which is triggered when an instruction is fetched from the specified location. If you have set the breakpoint on a specific machine instruction, the breakpoint will be triggered and the execution will temporarily halt and print the specified message in the C-SPY **Debug Log** window.

## Example

```

__var logBp1;
__var logBp2;

logOn()
{
    logBp1 = __setLogBreak ("{C:\\temp\\Utilities.c}.23.1",
        "\\Entering trace zone at :", #PC:%X", "ARGS", "1", "TRUE");
    logBp2 = __setLogBreak ("{C:\\temp\\Utilities.c}.30.1",
        "Leaving trace zone...", "TEXT", "1", "TRUE");
}

logOff()
{
    __clearBreak(logBp1);
    __clearBreak(logBp2);
}

```

## See also

*Formatted output*, page 315 and *Breakpoints*, page 103.

**\_\_setRangeBreak**

## Syntax

```

__setRangeBreak(start_loc, end_loc, end_cond, type, access,
                action, action_when)

```

## Parameters

All parameters are strings.

<i>start_loc</i>	<p>The start location. Choose between:</p> <p>A <i>source location</i> on the form "<i>{filename}.line.col</i>" (for example "<i>{D:\\src\\prog.c}.12.9</i>")</p> <p>An <i>absolute location</i> on the form "<i>zone:hexaddress</i>" or simply "<i>hexaddress</i>" (for example "<i>Memory:0x42</i>")</p> <p>An <i>expression</i> whose value designates a location (for example "<i>my_global_variable</i>").</p>
<i>end_loc</i>	The end location. This can be either the same as for <i>start_loc</i> above or the length of the range.
<i>end_cond</i>	The type of end condition: "Location", "Length", or "Automatic".
<i>type</i>	The breakpoint type: "Address" or "Data".
<i>access</i>	The memory access type: "Read", "Write", "ReadWrite", or "Fetch".

*action* The action type: "Break", "Trigger", or "BreakTrigger".

*action\_when* Specifies if the action should happen at an access inside or outside of the specified range: "Inside" or "Outside".

## Return value

Result	Value
Successful	An unsigned integer uniquely identifying the breakpoint. This value must be used to clear the breakpoint.
Unsuccessful	0

Table 35: `__setRangeBreak` return values

## For use with

The C-SPY FET Debugger driver.

## Description

Sets a range breakpoint.

## Example

```
__var brk;
brk = __setRangeBreak("Memory:0x1240", "Memory:0x1360",
    "Location", "Address", "Fetch", "Trigger", "Inside");
...
__clearBreak(brk);
```

## See also

*Breakpoints*, page 103.

**`__setSimBreak`**

## Syntax

```
__setSimBreak(location, access, action)
```

## Parameters

*location*

A string that defines the data location of the breakpoint, either a valid C-SPY expression whose value evaluates to a valid address or an absolute location. For more information about the location types, see *Enter Location dialog box*, page 132.

*access*

The memory access type: "R" for read or "W" for write.

*action*

An expression, typically a call to a macro, which is evaluated when the breakpoint is detected.

Return value

Result	Value
Successful	An unsigned integer uniquely identifying the breakpoint. This value must be used to clear the breakpoint.
Unsuccessful	0

Table 36: `__setSimBreak` return values

For use with

The C-SPY Simulator.

Description

Use this system macro to set *immediate* breakpoints, which will halt instruction execution only temporarily. This allows a C-SPY macro function to be called when the processor is about to read data from a location or immediately after it has written data. Instruction execution will resume after the action.

This type of breakpoint is useful for simulating memory-mapped devices of various kinds (for instance serial ports and timers). When the processor reads at a memory-mapped location, a C-SPY macro function can intervene and supply the appropriate data. Conversely, when the processor writes to a memory-mapped location, a C-SPY macro function can act on the value that was written.

## `__setTraceStartBreak`

Syntax

`__setTraceStartBreak(location)`

Parameters

*location*

A string that defines the code location of the breakpoint, either a valid C-SPY expression whose value evaluates to a valid address, an absolute location, or a source location. For more information about the location types, see *Enter Location dialog box*, page 132.

Return value

Result	Value
Successful	An unsigned integer uniquely identifying the breakpoint. The same value must be used when you want to clear the breakpoint.
Unsuccessful	0

Table 37: `__setTraceStartBreak` return values

For use with

The C-SPY Simulator.

Description

Sets a breakpoint at the specified location. When that breakpoint is triggered, the trace system is started.

## Example

```

__var startTraceBp;
__var stopTraceBp;

traceOn()
{
    startTraceBp = __setTraceStartBreak
        ("C:\\TEMP\\Utilities.c).23.1");
    stopTraceBp = __setTraceStopBreak
        ("C:\\temp\\Utilities.c).30.1");
}

traceOff()
{
    __clearBreak(startTraceBp);
    __clearBreak(stopTraceBp);
}

```

## See also

*Breakpoints*, page 103.

## \_\_setTraceStopBreak

## Syntax

```
__setTraceStopBreak(location)
```

## Parameters

*location*

A string that defines the code location of the breakpoint, either a valid C-SPY expression whose value evaluates to a valid address, an absolute location, or a source location. For more information about the location types, see *Enter Location dialog box*, page 132.

## Return value

Result	Value
Successful	An unsigned integer uniquely identifying the breakpoint. The same value must be used when you want to clear the breakpoint.
Unsuccessful	int 0

Table 38: *\_\_setTraceStopBreak* return values

## For use with

The C-SPY Simulator.

## Description

Sets a breakpoint at the specified location. When that breakpoint is triggered, the trace system is stopped.

## Example

See *\_\_setTraceStartBreak*, page 348.

See also *Breakpoints*, page 103.

## \_\_sourcePosition

Syntax `__sourcePosition(linePtr, colPtr)`

Parameters

*linePtr*  
Pointer to the variable storing the line number

*colPtr*  
Pointer to the variable storing the column number

Return value

Result	Value
Successful	Filename string
Unsuccessful	Empty ( " " ) string

Table 39: *\_\_sourcePosition* return values

For use with All C-SPY drivers.

Description If the current execution location corresponds to a source location, this macro returns the filename as a string. It also sets the value of the variables, pointed to by the parameters, to the line and column numbers of the source location.

## \_\_strFind

Syntax `__strFind(macroString, pattern, position)`

Parameters

*macroString*  
A macro string.

*pattern*  
The string pattern to search for

*position*  
The position where to start the search. The first position is 0

Return value The position where the pattern was found or -1 if the string is not found.

For use with All C-SPY drivers.

Description	This macro searches a given string ( <i>macroString</i> ) for the occurrence of another string ( <i>pattern</i> ).
Example	<pre>__strFind("Compiler", "pile", 0) = 3 __strFind("Compiler", "foo", 0) = -1</pre>
See also	<i>Macro strings</i> , page 313.

## \_\_subString

Syntax	<code>__subString(<i>macroString</i>, <i>position</i>, <i>length</i>)</code>
Parameters	<p><i>macroString</i> A macro string.</p> <p><i>position</i> The start position of the substring. The first position is 0.</p> <p><i>length</i> The length of the substring</p>
Return value	A substring extracted from the given macro string.
For use with	All C-SPY drivers.
Description	This macro extracts a substring from another string ( <i>macroString</i> ).
Example	<pre>__subString("Compiler", 0, 2) The resulting macro string contains Co. __subString("Compiler", 3, 4) The resulting macro string contains pile.</pre>
See also	<i>Macro strings</i> , page 313.

## \_\_targetDebuggerVersion

Syntax	<code>__targetDebuggerVersion()</code>
Return value	A string that represents the version number of the C-SPY debugger processor module.
For use with	All C-SPY drivers.

Description This macro returns the version number of the C-SPY debugger processor module.

Example

```
__var toolVer;
toolVer = __targetDebuggerVersion();
__message "The target debugger version is, ", toolVer;
```

## **\_\_toLower**

Syntax `__toLower(macroString)`

Parameters *macroString*

A macro string.

Return value The converted macro string.

For use with All C-SPY drivers.

Description This macro returns a copy of the parameter *macroString* where all the characters have been converted to lower case.

Example

```
__toLower("IAR")
The resulting macro string contains iar.
__toLower("Mix42")
The resulting macro string contains mix42.
```

See also *Macro strings*, page 313.

## **\_\_toString**

Syntax `__toString(C_string, maxlength)`

Parameters *C\_string*

Any null-terminated C string.

*maxlength*

The maximum length of the returned macro string.

Return value Macro string.

For use with All C-SPY drivers.



**Description** This macro is used for converting C strings (`char*` or `char []`) into macro strings.

**Example** Assuming your application contains this definition:

```
char const * hpstr = "Hello World!";
```

this macro call:

```
__toString(hpstr, 5)
```

would return the macro string containing `Hello`.

**See also** *Macro strings*, page 313.

## **\_\_ToUpper**

**Syntax** `__ToUpper(macroString)`

**Parameters** *macroString*  
A macro string.

**Return value** The converted string.

**For use with** All C-SPY drivers.

**Description** This macro returns a copy of the parameter *macroString* where all the characters have been converted to upper case.

**Example** `__ToUpper("string")`  
The resulting macro string contains `STRING`.

**See also** *Macro strings*, page 313.

## **\_\_unloadImage**

**Syntax** `__unloadImage(module_id)`

**Parameters** *module\_id*  
An integer which represents a unique module identification, which is retrieved as a return value from the corresponding `__loadImage` C-SPY macro.

Return value

Value	Result
<i>module_id</i>	A unique module identification (the same as the input parameter).
int 0	The unloading failed.

Table 40: *\_\_unloadImage* return values

For use with

All C-SPY drivers.

Description

Unloads debug information from an already downloaded image.

See also

*Loading multiple images*, page 47 and *Images*, page 391.

## **\_\_writeFile**

Syntax

`__writeFile(fileHandle, value)`

Parameters

*fileHandle*A macro variable used as filehandle by the `__openFile` macro.*value*

An integer.

Return value

int 0

For use with

All C-SPY drivers.

Description

Prints the integer value in hexadecimal format (with a trailing space) to the file *file*.**Note:** The `__fmessage` statement can do the same thing. The `__writeFile` macro is provided for symmetry with `__readFile`.

## **\_\_writeFileByte**

Syntax

`__writeFileByte(fileHandle, value)`

Parameters

*fileHandle*A macro variable used as filehandle by the `__openFile` macro.*value*

An integer.

Return value	<code>int 0</code>
For use with	All C-SPY drivers.
Description	Writes one byte to the file <i>fileHandle</i> .

## **\_\_writeMemory8, \_\_writeMemoryByte**

Syntax	<code>__writeMemory8(value, address, zone)</code> <code>__writeMemoryByte(value, address, zone)</code>
Parameters	<p><i>value</i> An integer.</p> <p><i>address</i> The memory address (integer).</p> <p><i>zone</i> A string that specifies the memory zone, see <i>C-SPY memory zones</i>, page 138.</p>
Return value	<code>int 0</code>
For use with	All C-SPY drivers.
Description	Writes one byte to a given memory location.
Example	<code>__writeMemory8(0x2F, 0x8020, "Memory");</code>

## **\_\_writeMemory16**

Syntax	<code>__writeMemory16(value, address, zone)</code>
Parameters	<p><i>value</i> An integer.</p> <p><i>address</i> The memory address (integer).</p> <p><i>zone</i> A string that specifies the memory zone, see <i>C-SPY memory zones</i>, page 138.</p>
Return value	<code>int 0</code>

For use with	All C-SPY drivers.
Description	Writes two bytes to a given memory location.
Example	<code>__writeMemory16(0x2FFF, 0x8020, "Memory");</code>

## **\_\_writeMemory32**

Syntax	<code>__writeMemory32(value, address, zone)</code>
Parameters	<p><i>value</i> An integer.</p> <p><i>address</i> The memory address (integer).</p> <p><i>zone</i> A string that specifies the memory zone, see <i>C-SPY memory zones</i>, page 138.</p>
Return value	<code>int 0</code>
For use with	All C-SPY drivers.
Description	Writes four bytes to a given memory location.
Example	<code>__writeMemory32(0x5555FFFF, 0x8020, "Memory");</code>

---

## **Graphical environment for macros**

Reference information about:

- *Macro Registration window*, page 357
- *Debugger Macros window*, page 359
- *Macro Quicklaunch window*, page 361

## Macro Registration window

The **Macro Registration** window is available from the **View>Macros** submenu during a debug session.

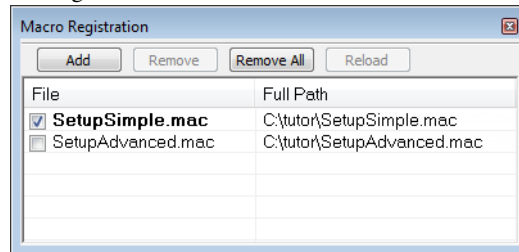

Use this window to list, register, and edit your debugger macro files.

Double-click a macro file to open it in the editor window and edit it.

See also *Registering C-SPY macros—an overview*, page 308.

### Requirements

None; this window is always available.

### Display area

This area contains these columns:

#### File

The name of an available macro file. To register the macro file, select the check box to the left of the filename. The name of a registered macro file appears in bold style.

#### Full path

The path to the location of the added macro file.

## Context menu

This context menu is available:

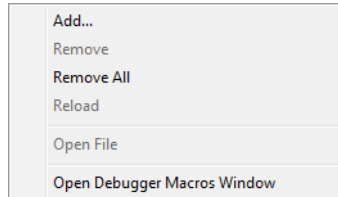

These commands are available:

### **Add**

Opens a file browser where you can locate the macro file that you want to add to the list. This menu command is also available as a function button at the top of the window.

### **Remove**

Removes the selected debugger macro file from the list. This menu command is also available as a function button at the top of the window.

### **Remove All**

Removes all macro files from the list. This menu command is also available as a function button at the top of the window.

### **Reload**

Registers the selected macro file. Typically, this is useful when you have edited a macro file. This menu command is also available as a function button at the top of the window.

### **Open File**

Opens the selected macro file in the editor window.

### **Open Debugger Macros Window**

Opens the Debugger Macros window.

## Debugger Macros window

The **Debugger Macros** window is available from the **View>Macros** submenu during a debug session.

Click the **Name** header or the **File** header to sort alphabetically on either function name or filename.

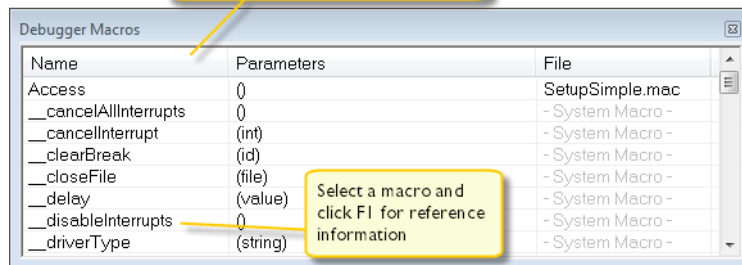

Use this window to list all registered debugger macro functions, either predefined system macros or your own. This window is useful when you edit your own macro functions and want an overview of all available macros that you can use.

- Click the column headers **Name** or **File** to sort alphabetically on either function name or filename.
- Double-clicking a macro defined in a file opens that file in the editor window.
- To open a macro in the **Macro Quicklaunch** window, drag it from the **Debugger Macros** window and drop it in the **Macro Quicklaunch** window.
- Select a macro and press F1 to get online help information for that macro.

### Requirements

None; this window is always available.

### Display area

This area contains these columns:

#### Name

The name of the debugger macro.

#### Parameters

The parameters of the debugger macro.

#### File

For macros defined in a file, the name of the file is displayed. For predefined system macros, -System Macro- is displayed.

## Context menu

This context menu is available:

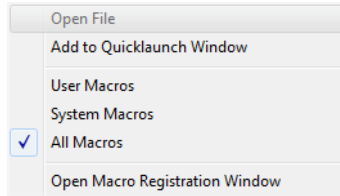

These commands are available:

### **Open File**

Opens the selected debugger macro file in the editor window.

### **Add to Quicklaunch Window**

Adds the selected macro to the **Macro Quicklaunch** window.

### **User Macros**

Lists only the debugger macros that you have defined yourself.

### **System Macros**

Lists only the predefined system macros.

### **All Macros**

Lists all debugger macros, both predefined system macros and your own.

### **Open Macro Registration Window**

Opens the **Macro Registration** window.



## Macro Quicklaunch window

The **Macro Quicklaunch** window is available from the **View** menu.

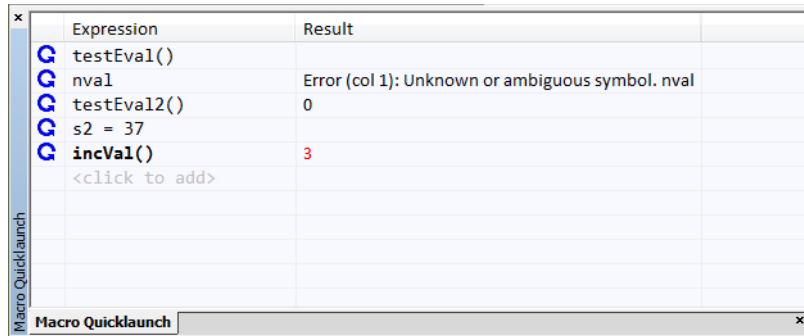

Use this window to evaluate expressions, typically C-SPY macros.

For some devices, there are predefined C-SPY macros available with device support, typically provided by the chip manufacturer. These macros are useful for performing certain device-specific tasks. The macros are available in the **Macro Quicklaunch** window and are easily identified by their green icon,

The **Macro Quicklaunch** window is similar to the **Quick Watch** window, but is primarily designed for evaluating C-SPY macros. The window gives you precise control over when to evaluate an expression.

See also *Executing C-SPY macros—an overview*, page 308.

### To add an expression:

- I Choose one of these alternatives:
  - Drag the expression to the window
  - In the **Expression** column, type the expression you want to examine.

If the expression you add and want to evaluate is a C-SPY macro, the macro must first be registered, see *Registering C-SPY macros—an overview*, page 308.

### To evaluate an expression:



- I Double-click the **Recalculate** icon to calculate the value of that expression.

### Requirements

None; this window is always available.

## Display area

This area contains these columns:



### Recalculate icon

To evaluate the expression, double-click the icon. The latest evaluated expression appears in bold style.

### Expression

One or several expressions that you want to evaluate. Click <click to add> to add an expression. If the return value has changed since last time, the value will be displayed in red.

### Result

Shows the return value from the expression evaluation.

## Context menu

This context menu is available:

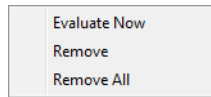

These commands are available:

### Evaluate Now

Evaluates the selected expression.

### Remove

Removes the selected expression.

### Remove All

Removes all selected expressions.

# The C-SPY command line utility—`cspybat`

- Using C-SPY in batch mode
- Summary of C-SPY command line options
- Reference information on C-SPY command line options.

---

## Using C-SPY in batch mode

You can execute C-SPY in batch mode if you use the command line utility `cspybat`, installed in the directory `common\bin`.

These topics are covered:

- Starting `cspybat`
- Output
- Invocation syntax

### STARTING CSPYBAT

- 1 To start `cspybat` you must first create a batch file. An easy way to do that is to use one of the batch files that C-SPY automatically generates when you start C-SPY in the IDE.

C-SPY generates a batch file `projectname.buildconfiguration.cspy.bat` every time C-SPY is initialized. In addition, two more files are generated:

- `project.buildconfiguration.general.xml`, which contains options specific to `cspybat`.
- `project.buildconfiguration.driver.xml`, which contains options specific to the C-SPY driver you are using.

You can find the files in the directory `$PROJ_DIR$\settings`. The files contain the same settings as the IDE, and provide hints about additional options that you can use.

- 2 To start `cspybat`, you can use this command line:

```
project.cspybat.bat [debugfile]
```

Note that *debugfile* is optional. You can specify it if you want to use a different debug file than the one that is used in the *project.buildconfiguration.general.xml* file.

## OUTPUT

When you run *cspybat*, these types of output can be produced:

- Terminal output from *cspybat* itself
 

All such terminal output is directed to *stderr*. Note that if you run *cspybat* from the command line without any arguments, the *cspybat* version number and all available options including brief descriptions are directed to *stdout* and displayed on your screen.
- Terminal output from the application you are debugging
 

All such terminal output is directed to *stdout*, provided that you have used the *--plugin* option. See *--plugin*, page 381.
- Error return codes
 

*cspybat* returns status information to the host operating system that can be tested in a batch file. For *successful*, the value *int 0* is returned, and for *unsuccessful* the value *int 1* is returned.

## INVOCATION SYNTAX

The invocation syntax for *cspybat* is:

```
cspybat processor_DLL driver_DLL debug_file
        [cspybat_options] --backend driver_options
```

**Note:** In those cases where a filename is required—including the DLL files—you are recommended to give a full path to the filename.

## Parameters

The parameters are:

Parameter	Description
<i>processor_DLL</i>	The processor-specific DLL file; available in 430\bin.
<i>driver_DLL</i>	The C-SPY driver DLL file; available in 430\bin.
<i>debug_file</i>	The object file that you want to debug (filename extension d43). See also <i>--debugfile</i> , page 371.
<i>cspybat_options</i>	The command line options that you want to pass to <i>cspybat</i> . Note that these options are optional. For information about each option, see <i>Reference information on C-SPY command line options</i> , page 367.

Table 41: *cspybat* parameters

Parameter	Description
<code>--backend</code>	Marks the beginning of the parameters to the C-SPY driver; all options that follow will be sent to the driver. Note that this option is mandatory.
<code>driver_options</code>	The command line options that you want to pass to the C-SPY driver. Note that some of these options are mandatory and some are optional. For information about each option, see <i>Reference information on C-SPY command line options</i> , page 367.

Table 41: cspybat parameters (Continued)

## Summary of C-SPY command line options

Reference information about:

- General cspybat options
- Options available for all C-SPY drivers
- Options available for the simulator driver
- Options available for the C-SPY FET Debugger driver

### GENERAL CSPYBAT OPTIONS

<code>--attach_to_running_target</code>	Makes the debugger attach to a running application at its current location, without resetting the target system.
<code>--backend</code>	Marks the beginning of the parameters to be sent to the C-SPY driver (mandatory).
<code>--code_coverage_file</code>	Enables the generation of code coverage information and places it in a specified file.
<code>--cycles</code>	Specifies the maximum number of cycles to run.
<code>--debugfile</code>	Specifies an alternative debug file.
<code>--downloadonly</code>	Downloads a code image without starting a debug session afterwards.
<code>-f</code>	Extends the command line.
<code>--leave_target_running</code>	Makes the debugger leave the application running on the target hardware after the debug session is closed.
<code>--macro</code>	Specifies a macro file to be used.
<code>--macro_param</code>	Assigns a value to a C-SPY macro parameter.

<code>--plugin</code>	Specifies a plugin file to be used.
<code>--silent</code>	Omits the sign-on message.
<code>--timeout</code>	Limits the maximum allowed execution time.

### **OPTIONS AVAILABLE FOR ALL C-SPY DRIVERS**

<code>--core</code>	Specifies the core to be used.
<code>-d</code>	Specifies the C-SPY driver to be used.
<code>-p</code>	Specifies the device description file to be used.

### **OPTIONS AVAILABLE FOR THE SIMULATOR DRIVER**

<code>--disable_interrupts</code>	Disables the interrupt simulation.
<code>--function_profiling</code>	Analyzes your source code to find where the most time is spent during execution.
<code>--mapu</code>	Activates memory access checking.
<code>--odd_word_check</code>	Stops the execution if an access to an odd address is found.

### **OPTIONS AVAILABLE FOR THE C-SPY FET DEBUGGER DRIVER**

<code>--allow_access_to_BSL</code>	Enables erase/write access to BSL flash memory.
<code>--allow_locked_flash_access</code>	Enables erase/write access to locked flash memory.
<code>--connection</code>	Specifies the communication channel to be used.
<code>--derivative</code>	Specifies the device.
<code>--disable_memory_cache</code>	Disables the memory cache in the FET debugger.
<code>--eem</code>	Specifies the level of Enhanced Emulation Mode.
<code>--erase_exclude</code>	Excludes a memory segment from erase.
<code>--erase_ip_protected</code>	Erases main and Information flash memories, including the IP protected area before download.

<code>--erase_main</code>	Erases main flash memory before download.
<code>--erase_main_and_info</code>	Erases the main and Information flash memories before download.
<code>--erase_retain_file</code>	Retains unchanged memory during download.
<code>--erase_retain_target</code>	Retains unchanged memory during download.
<code>--hardware_multiplier</code>	Generates code for the hardware multiplier peripheral unit.
<code>--hwmult_type</code>	Specifies the type of hardware multiplier to be used.
<code>--jtag_speed</code>	Specifies the JTAG communication speed.
<code>--lptx</code>	Specifies the parallel port to be used.
<code>--port</code>	Specifies the serial port to be used.
<code>--protocol</code>	Specifies the debug protocol to be used.
<code>--set_exit_breakpoint</code>	Sets a system breakpoint on <code>exit</code> .
<code>--set_getchar_breakpo</code> <code>int</code>	Sets a system breakpoint on <code>getchar</code> .
<code>--set_putchar_breakpo</code> <code>int</code>	Sets a system breakpoint on <code>putchar</code> .
<code>--settlingtime</code>	Specifies the delay after setting the voltage.
<code>--use_emulated_breakp</code> <code>oints</code>	Allows C-SPY to use emulated breakpoints.
<code>--use_virtual_breakpo</code> <code>ints</code>	Allows C-SPY to use virtual breakpoints.
<code>--vccvoltage</code>	Specifies the voltage provided by the USB interface.
<code>--verify_all</code>	Verifies the download of your application.

---

## Reference information on C-SPY command line options

This section gives detailed reference information about each `cspybat` option and each option available to the C-SPY drivers.

**--allow\_access\_to\_BSL**

Syntax `--allow_access_to_BSL`

For use with The C-SPY FET Debugger driver.

Description Use this option to enable erase/write access to BSL flash memory.



**Project>Options>Debugger>FET Debugger>Download>Allow erase/write access to BSL flash memory**

**--allow\_locked\_flash\_access**

Syntax `--allow_locked_flash_access`

For use with The C-SPY FET Debugger driver.

Description Use this option to enable erase/write access to locked flash memory.



**Project>Options>Debugger>FET Debugger>Download>Allow erase/write access to locked flash memory**

**--attach\_to\_running\_target**

Syntax `--attach_to_running_target`

For use with `cspybat`.

**Note:** This option might not be supported by the combination of C-SPY driver and device that you are using. If you are using this option with an unsupported combination, C-SPY produces a message.

Description Use this option to make the debugger attach to a running application at its current location, without resetting the target system.

If you have defined any breakpoints in your project, the C-SPY driver will set them during attachment. If the C-SPY driver cannot set them without stopping the target system, the breakpoints will be disabled. The option also suppresses download and the **Run to** option.



**Project>Attach to Running Target**



**--backend**

Syntax	<code>--backend {driver options}</code>
Parameters	<i>driver options</i> Any option available to the C-SPY driver you are using.
For use with	<code>cspybat</code> (mandatory).
Description	Use this option to send options to the C-SPY driver. All options that follow <code>--backend</code> will be passed to the C-SPY driver, and will not be processed by <code>cspybat</code> itself.
	 This option is not available in the IDE.

**--connection**

Syntax	<code>--connection Port</code>
Parameters	<i>Port</i> The communication channel to be used; choose between: <code>ti_usb</code> , <code>ti_lpt</code> , <code>jlink</code> , <code>olimex</code> , <code>olimex_parallel</code> , <code>elprotonic</code> , <code>softbaugh_lpt</code> , <code>softbaugh_usb</code> , and <code>softbaugh_usb_pro</code> .
For use with	The C-SPY FET Debugger driver.
Description	Use this option to specify the communication channel to be used between C-SPY and the target system.
	 <b>Project&gt;Options&gt;Debugger&gt;FET Debugger&gt;Setup&gt;Connection</b>

**--core**

Syntax	<code>--core {430X 430Xv2}</code>
Parameters	<code>430X 430Xv2</code> The core you are using. This option reflects the corresponding compiler option.
For use with	All C-SPY drivers.
Description	Use this option to specify the core you are using.

See also

The *IAR C/C++ Compiler User Guide for MSP430* for information about the cores.**Project>Options>General Options>Target>Device**

## --code\_coverage\_file

Syntax

`--code_coverage_file file`Note that this option must be placed before the `--backend` option on the command line.

Parameters

*file*

The name of the destination file for the code coverage information.

For use with

`cspybat`

Description

Use this option to enable the generation of a text-based report file for code coverage information. The code coverage information will be generated after the execution has completed and you can find it in the specified file. Because most embedded applications do not terminate, you might have to use this option in combination with `--timeout` or `--cycles`.

Note that this option requires that the C-SPY driver you are using supports code coverage. If you try to use this option with a C-SPY driver that does not support code coverage, an error message will be directed to `stderr`.

See also

*Code coverage*, page 231, *--cycles*, page 370, *--timeout*, page 384.To set this option, choose **View>Code Coverage**, right-click and choose **Save As** when the C-SPY debugger is running.

## --cycles

Syntax

`--cycles cycles`Note that this option must be placed before the `--backend` option on the command line.

Parameters

*cycles*

The number of cycles to run.

For use with

`cspybat`

Description

Use this option to specify the maximum number of cycles to run. If the target program executes longer than the number of cycles specified, the target program will be aborted.

Using this option requires that the C-SPY driver you are using supports a cycle counter, and that it can be sampled while executing.



This option is not available in the IDE.

## **-d**

Syntax	<code>-d {sim fet}</code>				
Parameters	<table> <tr> <td><code>sim</code></td> <td>Specifies the simulator driver.</td> </tr> <tr> <td><code>fet</code></td> <td>Specifies the FET debugger driver.</td> </tr> </table>	<code>sim</code>	Specifies the simulator driver.	<code>fet</code>	Specifies the FET debugger driver.
<code>sim</code>	Specifies the simulator driver.				
<code>fet</code>	Specifies the FET debugger driver.				
For use with	All C-SPY drivers.				
Description	Use this option to specify the C-SPY driver to be used.				



**Project>Options>Debugger>Setup>Driver**

## **--debugfile**

Syntax	<code>--debugfile <i>filename</i></code>		
Parameters	<table> <tr> <td><i>filename</i></td> <td>The name of the debug file to use.</td> </tr> </table>	<i>filename</i>	The name of the debug file to use.
<i>filename</i>	The name of the debug file to use.		
For use with	<p><code>cspybat</code></p> <p>This option can be placed both before and after the <code>--backend</code> option on the command line.</p>		
Description	Use this option to make <code>cspybat</code> use the specified debugfile instead of the one used in the generated <code>cpsybat.bat</code> file.		



This option is not available in the IDE.

**--derivative**

Syntax	<code>--derivative <i>device</i></code>
Parameters	<i>device</i> Specifies the device to be used.
For use with	The C-SPY FET Debugger driver.
Description	Use this option to select the device for which you will build your application.



**Project>Options>General Options>Target>Device**

**--disable\_interrupts**

Syntax	<code>--disable_interrupts</code>
For use with	The C-SPY Simulator driver.
Description	Use this option to disable the interrupt simulation.



To set this option, choose **Simulator>Interrupt Setup** and deselect the **Enable interrupt simulation** option.

**--disable\_memory\_cache**

Syntax	<code>--disable_memory_cache</code>
For use with	The C-SPY FET Debugger driver.
Description	Use this option to disable the memory cache in the FET debugger.



**Project>Options>Debugger>FET Debugger>Setup>Disable memory cache**

**--downloadonly**

Syntax	<code>--downloadonly</code>
	Note that this option must be placed before the <code>--backend</code> option on the command line.

For use with	cspybat
Description	Use this option to download the code image without starting a debug session afterwards.



**Project>Download>Download active application**

## --eem

Syntax	<code>--eem {level}</code>
Parameters	<p><i>level</i> Implementation level of Enhanced Emulation Module. Choose between:</p> <ul style="list-style-type: none"> <li>EMEX_LOW</li> <li>EMEX_MEDIUM</li> <li>EMEX_HIGH</li> <li>EMEX_EXTRA_SMALL_5XX</li> <li>EMEX_SMALL_5XX</li> <li>EMEX_MEDIUM_5XX</li> <li>EMEX_LARGE_5XX</li> <li>EMEX_NONE</li> </ul>

For use with	The C-SPY FET Debugger driver.
Description	Use this option to specify the implementation level of Enhanced Emulation Module for a MSP430 device. The default value is <code>EMEX_NONE</code> . The value of this option depends on the device you are using.



This option is automatically set when you are using the IDE.

**--erase\_exclude**

Syntax	<code>--erase_exclude range</code>
Parameters	<i>range</i> The memory range of the segment, in the form <i>startaddress-endaddress</i> .
For use with	The C-SPY FET Debugger driver.
Description	Use this option to exclude a memory segment from erase. The segments that overlap with the specified area will not be erased.
Example	<code>--erase_exclude 0x2180-0x2220</code>



To set this option, use **Project>Options>Debugger>Extra Options**.

**--erase\_ip\_protected**

Syntax	<code>--erase_ip_protected</code>
For use with	The C-SPY FET Debugger driver.
Description	Use this option to erase the main and Information flash memories, including the IP protected area before download.



**Project>Options>Debugger>FET Debugger>Download>Erase main and Information memory inc. IP PROTECTED area**

**--erase\_main**

Syntax	<code>--erase_main</code>
For use with	The C-SPY FET Debugger driver.
Description	Use this option to erase the main flash memory before download. The Information memory is not erased.



**Project>Options>Debugger>FET Debugger>Download>Erase main memory**

**--erase\_main\_and\_info**

Syntax	--erase_main_and_info
For use with	The C-SPY FET Debugger driver.
Description	Use this option to erase both flash memories—main and Information memory—before download.



**Project>Options>Debugger>FET Debugger>Download>Erase main and Information memory**

**--erase\_retain\_file**

Syntax	--erase_retain_file
For use with	The C-SPY FET Debugger driver.
Description	Use this option to make C-SPY read the main and Information memories into a buffer. Only the flash segments that are needed are erased. If data that is to be written into a segment matches the data in the image that is cached on the host computer, the data in the image is left as is, and no download is performed. The new data effectively replaces the old data, and unchanged old data is retained.



**Project>Options>Debugger>FET Debugger>Download>Retain unchanged memory>Compare with image cached on PC**

**--erase\_retain\_target**

Syntax	--erase_retain_target
For use with	The C-SPY FET Debugger driver.
Description	Use this option to make C-SPY read the main and Information memories into a buffer. Only the flash segments that are needed are erased. If data that is to be written into a segment matches the data on the target, the data on the target is left as is, and no download is performed. The new data effectively replaces the old data, and unchanged old data is retained.



**Project>Options>Debugger>FET Debugger>Download>Retain unchanged memory>Compare with image on target**

**-f**

Syntax	<code>-f filename</code>
Parameters	<i>filename</i> A text file that contains the command line options (default filename extension <code>.xcl</code> ).
For use with	<code>cspybat</code> This option can be placed either before or after the <code>--backend</code> option on the command line.
Description	Use this option to make <code>cspybat</code> read command line options from the specified file.  In the command file, you format the items exactly as if they were on the command line itself, except that you may use multiple lines, because the newline character is treated like a space or tab character.  Both C/C++ style comments are allowed in the file. Double quotes behave in the same way as in the Microsoft Windows command line environment.



To set this option, use **Project>Options>Debugger>Extra Options**.

**--function\_profiling**

Syntax	<code>--function_profiling filename</code>
Parameters	<i>filename</i> The name of the log file where the profiling data is saved.
For use with	The C-SPY simulator driver.
Description	Use this option to find the functions in your source code where the most time is spent during execution. The profiling information is saved to the specified file. For more information about function profiling, see <i>Profiling</i> , page 221.



**C-SPY driver>Function Profiling**



## --hardware\_multiplier

Syntax	<code>--hardware_multiplier {16 32}</code>	
Parameters	16	The size of the multiplicands in bits. Note that this parameter can only be used in combination with the <code>--hwmult_type</code> parameters 1 and 2.
	32	The size of the multiplicands in bits. Note that this parameter can only be used in combination with the <code>--hwmult_type</code> parameters 4 and 8.
For use with	The C-SPY FET Debugger driver.	
Description	Use this option to generate code for the MSP430 hardware multiplier peripheral unit. Use this option only when you have chosen a device with a hardware multiplier.	
	<b>Note:</b> This option requires that you also specify the <code>--hwmult_type</code> option.	
		To set related options, choose: <b>Project&gt;Options&gt;General Options&gt;Target&gt;Hardware multiplier</b>

## --hwmult\_type

Syntax	<code>--hwmult_type {1 2 4 8}</code>	
Parameters	1	16 bits Note that this parameter can only be combined with the <code>--hardware_multiplier</code> parameter 16.
	2	16 bits, the 2xx Family Note that this parameter can only be combined with the <code>--hardware_multiplier</code> parameter 16.
	4	32 bits Note that this parameter can only be combined with the <code>--hardware_multiplier</code> parameter 32.

8                    32 bits, the 5xx Families

Note that this parameter can only be combined with the `--hardware_multiplier` parameter 32.

For use with                    The C-SPY FET Debugger driver.

Description                    Use this option to generate code for the MSP430 hardware multiplier peripheral unit. Use this option only when you have chosen a device with a hardware multiplier.

**Note:** This option requires that you also specify the `--hardware_multiplier` option.



To set related options, choose:

**Project>Options>General Options>Target>Hardware multiplier**

## **--jtag\_speed**

Syntax                            `--jtag_speed{fast|medium|slow}`

Parameters

<code>fast</code>	The fast communication speed.
<code>medium</code>	The medium communication speed.
<code>slow</code>	The slow communication speed.

For use with                    The C-SPY FET Debugger driver.

Description                    Use this option to set the JTAG communication speed.



**Project>Options>Debugger>Fet Debugger>Setup>Jtag speed**

## **--leave\_target\_running**

Syntax                            `--leave_target_running`

For use with                    `cspybat`.

The C-SPY FET Debugger driver.

**Note:** Even if this option is supported by the C-SPY driver you are using, there might be device-specific limitations.

**Description** Use this option to make the debugger leave the application running on the target hardware after the debug session is closed.



Any existing breakpoints will not be automatically removed. You might want to consider disabling all breakpoints before using this option.



**C-SPY driver>Leave Target Running**

## --lptx

**Syntax** `--lptx`

**For use with** The C-SPY FET Debugger driver.

**Description** Use this option to specify which parallel port the FET Debugger is connected to. *x* can be 1, 2, or 3.



**Project>Options>Debugger>FET Debugger>Setup>Parallel port**

## --macro

**Syntax** `--macro filename`

Note that this option must be placed before the `--backend` option on the command line.

**Parameters** *filename*

The C-SPY macro file to be used (filename extension `mac`).

**For use with** `cspybat`

**Description** Use this option to specify a C-SPY macro file to be loaded before executing the target application. This option can be used more than once on the command line.

**See also** *Briefly about using C-SPY macros*, page 306.



**Project>Options>Debugger>Setup>Setup macros>Use macro file**

**--macro\_param**

Syntax	<code>--macro_param [param=value]</code>
	Note that this option must be placed before the <code>--backend</code> option on the command line.
Parameters	<code>param = value</code> <code>param</code> is a parameter defined using the <code>__param</code> C-SPY macro construction. <code>value</code> is a value.
For use with	<code>cspybat</code>
Description	Use this option to assign a value to a C-SPY macro parameter. This option can be used more than once on the command line.
See also	<i>Macro parameters</i> , page 313.



**Project>Options>Debugger>Extra Options**

**--mapu**

Syntax	<code>--mapu</code>
For use with	The C-SPY simulator driver.
Description	Specify this option to use the segment information in the debug file for memory access checking. During the execution, the simulator will then check for accesses to unspecified memory ranges. If any such access is found, the C function call stack and a message will be printed on <code>stderr</code> and the execution will stop.
See also	<i>Monitoring memory and registers</i> , page 140.



To set related options, choose:

**Simulator>Memory Access Setup**

**--odd\_word\_check**

Syntax	<code>--odd_word_check</code>
For use with	The C-SPY simulator driver.

**Description** Use this option to make the simulator issue a warning if there is a word access to an odd address.



**Project>Options>Debugger>Simulator>Setup>Check for word access on odd address**

## **-p**

**Syntax** `-p filename`

**Parameters** `filename`

The device description file to be used.

**For use with** All C-SPY drivers.

**Description** Use this option to specify the device description file to be used.

**See also** *Selecting a device description file*, page 44.



**Project>Options>Debugger>Setup>Device description file**

## **--plugin**

**Syntax** `--plugin filename`

Note that this option must be placed before the `--backend` option on the command line.

**Parameters** `filename`

The plugin file to be used (filename extension `.dll`).

**For use with** `cspybat`

**Description** Certain C/C++ standard library functions, for example `printf`, can be supported by C-SPY—for example, the C-SPY **Terminal I/O** window—instead of by real hardware devices. To enable such support in `cspybat`, a dedicated plugin module called `430bat.dll` located in the `430\bin` directory must be used.

Use this option to include this plugin during the debug session. This option can be used more than once on the command line.

**Note:** You can use this option to include also other plugin modules, but in that case the module must be able to work with `cspybat` specifically. This means that the C-SPY

plugin modules located in the `common\plugin` directory cannot normally be used with `cspybat`.



### Project>Options>Debugger>Plugins

## --port

Syntax	<code>--port port</code>
Parameters	<p><code>port</code> The serial port to be used, can be <code>COMx</code> or <code>Automatic</code>. <code>x</code> is the number of the COM port.</p>
For use with	The C-SPY FET Debugger driver.
Description	Use this option to specify which serial port the FET Debugger is connected to.



### Project>Options>Debugger>FET Debugger>Setup>Connection

## --protocol

Syntax	<code>--protocol {spy-bi-wire spy-bi-wire-jtag 4wire}</code>
Parameters	<p><code>spy-bi-wire</code> The Spy-Bi-Wire JTAG protocol.</p> <p><code>spy-bi-wire-jtag</code> 4-wire JTAG protocol for devices that also support Spy-Bi-Wire.</p> <p><code>4wire</code> The ordinary 4-wire JTAG protocol.</p>
For use with	The C-SPY FET Debugger driver.
Description	Use this option to specify the debug protocol. Spy-Bi-Wire works for the parallel port FET module and the TI USB FET module.



### Project>Options>Debugger>FET Debugger>Setup>Debug protocol

## --set\_exit\_breakpoint

Syntax `--set_exit_breakpoint`

For use with The C-SPY FET Debugger driver.

Description Use this option to set a system breakpoint for `exit`.



**Project>Options>Debugger>FET Debugger>Breakpoints>System breakpoints on>exit**

## --set\_getchar\_breakpoint

Syntax `--set_getchar_breakpoint`

For use with The C-SPY FET Debugger driver.

Description Use this option to set a system breakpoint for `getchar`.



**Project>Options>Debugger>FET Debugger>Breakpoints>System breakpoints on>getchar**

## --set\_putchar\_breakpoint

Syntax `--set_putchar_breakpoint`

For use with The C-SPY FET Debugger driver.

Description Use this option to set a system breakpoint for `putchar`.



**Project>Options>Debugger>FET Debugger>Breakpoints>System breakpoints on>putchar**

## --settlingtime

Syntax `--settlingtime=milliseconds`

For use with The C-SPY FET Debugger driver.

Description Use this option to specify the delay between switching on the target VCC and starting the identification of the MSP430 device. Give the value in milliseconds in the range 0-9999 ms. This option can only be used with a USB connection.



**Project>Options>Debugger>FET Debugger>Setup>Target VCC>Settling time (in ms)**

## --silent

Syntax

`--silent`

Note that this option must be placed before the `--backend` option on the command line.

For use with

`cspybat`

Description

Use this option to omit the sign-on message.



This option is not available in the IDE.

## --timeout

Syntax

`--timeout milliseconds`

Note that this option must be placed before the `--backend` option on the command line.

Parameters

*milliseconds*

The number of milliseconds before the execution stops.

For use with

`cspybat`

Description

Use this option to limit the maximum allowed execution time.



This option is not available in the IDE.

## --use\_emulated\_breakpoints

Syntax

`--use_emulated_breakpoints`

For use with

The C-SPY FET Debugger driver.

Description

Use this option to allow C-SPY to use emulated breakpoints.



**Project>Options>Debugger>FET Debugger>Breakpoints>Use software breakpoints>Emulated breakpoints**



**--use\_virtual\_breakpoints**

Syntax `--use_virtual_breakpoints`

For use with The C-SPY FET Debugger driver.

Description Use this option to allow C-SPY to use virtual breakpoints.



**Project>Options>Debugger>FET Debugger>Breakpoints>Use software breakpoints>Virtual breakpoints**

**--vccvoltage**

Syntax `--vccvoltage=volts`

For use with The C-SPY FET Debugger driver.

Description Use this option to specify the voltage provided by the USB interface. Give the value in Volts with one decimal's precision in the range 1.0-4.0 V. This option can only be used with a USB connection.



**Project>Options>Debugger>FET Debugger>Setup>Target VCC>Target VCC (in Volt)**

**--verify\_all**

Syntax `--verify_all`

For use with The C-SPY FET Debugger driver.

Description Use this option to verify that the downloaded code image can be read back from target memory with the correct contents.



**Project>Options>Debugger>FET Debugger>Download>Verify download**



# Part 4. Additional reference information

This part of the *C-SPY® Debugging Guide for MSP430* includes these chapters:

- Debugger options
- Additional information on C-SPY drivers

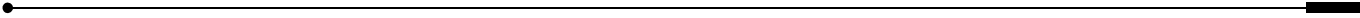



# Debugger options

- Setting debugger options
- Reference information on general debugger options
- Reference information on the C-SPY simulator
- Reference information on C-SPY hardware debugger driver options

---

## Setting debugger options

Before you start the C-SPY debugger you might need to set some options—both C-SPY generic options and options required for the target system (C-SPY driver-specific options).

### To set debugger options in the IDE:

- 1 Choose **Project>Options** to display the **Options** dialog box.
- 2 Select **Debugger** in the **Category** list.

For more information about the generic options, see *Reference information on general debugger options*, page 390.

- 3 On the **Setup** page, make sure to select the appropriate C-SPY driver from the **Driver** drop-down list.
- 4 To set the driver-specific options, select the appropriate driver from the **Category** list. Depending on which C-SPY driver you are using, different options are available.

C-SPY driver	Available options pages
C-SPY FET Debugger driver	<i>Setup for FET Debugger</i> , page 395 <i>Download</i> , page 397 <i>Breakpoints</i> , page 398
C-SPY Simulator	<i>Setup options for the simulator</i> , page 394

Table 42: Options specific to the C-SPY drivers you are using

- 5 To restore all settings to the default factory settings, click the **Factory Settings** button.
- 6 When you have set all the required options, click **OK** in the **Options** dialog box.

## Reference information on general debugger options

Reference information about:

- Setup
- Images
- Extra Options
- Plugins

### Setup

The general **Setup** options select the C-SPY driver, the setup macro file, and device description file to use, and specify which default source code location to run to.

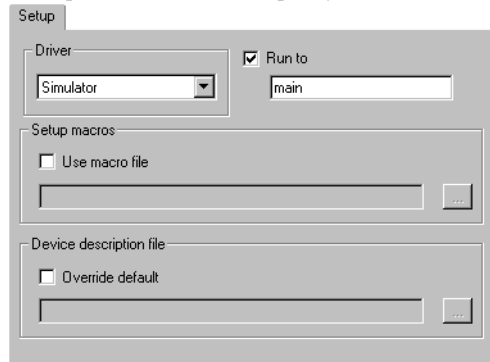

#### Driver

Selects the C-SPY driver for the target system you have.

#### Run to

Specifies the location C-SPY runs to when the debugger starts after a reset. By default, C-SPY runs to the `main` function.

To override the default location, specify the name of a different location you want C-SPY to run to. You can specify assembler labels or whatever can be evaluated as such, for example function names.

If the option is deselected, the program counter will contain the regular hardware reset address at each reset.

See also *Executing from reset*, page 44.

## Setup macros

Registers the contents of a setup macro file in the C-SPY startup sequence. Select **Use macro file** and specify the path and name of the setup file, for example `SetupSimple.mac`. If no extension is specified, the extension `mac` is assumed. A browse button is available for your convenience.

## Device description file

A default device description file is selected automatically based on your project settings. To override the default file, select **Override default** and specify an alternative file. A browse button is available for your convenience.

For information about the device description file, see *Modifying a device description file*, page 48.

Device description files for each MSP430 device are provided in the directory `430\config` and have the filename extension `ddf`.

## Images

The **Images** options control the use of additional debug files to be downloaded.

The screenshot shows a dialog box titled "Images" with a light green background. It contains three vertically stacked sections, each for configuring an additional debug file to be downloaded. Each section starts with a checkbox labeled "Download extra image". Below this is a "Path:" text box followed by a browse button (three dots). To the right of the "Path:" box is a "Debug info only" checkbox. Below the "Path:" box is an "Offset:" text box.

## Download extra Images

Controls the use of additional debug files to be downloaded:

### Path

Specify the debug file to be downloaded. A browse button is available for your convenience.

### Offset

Specify an integer that determines the destination address for the downloaded debug file.

### Debug info only

Makes the debugger download only debug information, and not the complete debug file.

If you want to download more than three images, use the related C-SPY macro, see `__loadImage`, page 329.

For more information, see *Loading multiple images*, page 47.

## Plugins

The **Plugins** options select the C-SPY plugin modules to be loaded and made available during debug sessions.

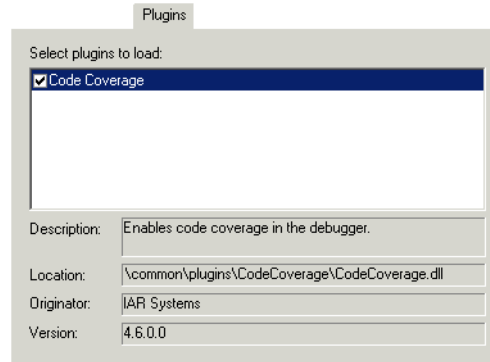

### Select plugins to load

Selects the plugin modules to be loaded and made available during debug sessions. The list contains the plugin modules delivered with the product installation.

### Description

Describes the plugin module.

### Location

Informs about the location of the plugin module.

Generic plugin modules are stored in the `common\plugins` directory. Target-specific plugin modules are stored in the `430\plugins` directory.

### Originator

Informs about the originator of the plugin module, which can be modules provided by IAR Systems or by third-party vendors.



## Version

Informs about the version number.

## Extra Options

The **Extra Options** page provides you with a command line interface to C-SPY.

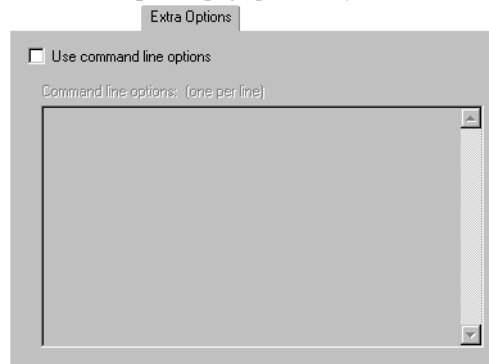

### Use command line options

Specify command line arguments that are not supported by the IDE to be passed to C-SPY.

Note that it is possible to use the `/args` option to pass command line arguments to the debugged application.

Syntax: `/args arg0 arg1 ...`

Multiple lines with `/args` are allowed, for example:

```
/args --logfile log.txt
```

```
/args --verbose
```

If you use `/args`, these variables must be defined in your application:

```
/* __argc, the number of arguments in __argv. */
__no_init int __argc;

/* __argv, an array of pointers to strings that holds the
arguments; must be large enough to fit the number of
parameters.*/
__no_init const char * __argv[MAX_ARGS];

/* __argvbuf, a storage area for __argv; must be large enough to
hold all command line parameters. */
__no_init __root char __argvbuf[MAX_ARG_SIZE];
```

---

## Reference information on the C-SPY simulator

Reference information about:

- Setup options for the simulator

This section gives reference information on the C-SPY simulator options.

### Setup options for the simulator

The simulator **Setup** options control the C-SPY simulator.

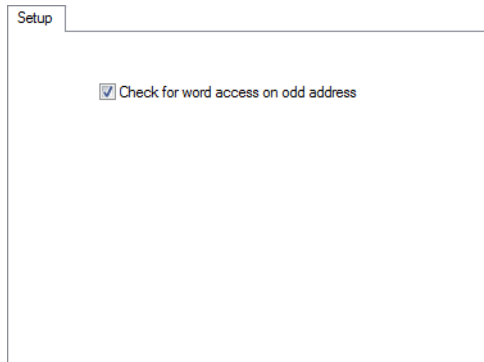

#### Check for word access on odd address

Makes the simulator issue a warning if there is a word access to an odd address.

## Reference information on C-SPY hardware debugger driver options

Reference information about:

- *Setup for FET Debugger*, page 395
- *Download*, page 397
- *Breakpoints*, page 398

### Setup for FET Debugger

The FET Debugger **Setup** options control the C-SPY FET Debugger driver.

#### Connection

Controls the communication between C-SPY and the target device.

The C-SPY FET Debugger can communicate with the target device via a number of different emulators. Select the emulator you are using.

If your emulator is connected to the host computer via a parallel port, you must also specify which parallel port to use: Parallel port 1, Parallel port 2, or Parallel port 3. If your emulator is connected to the host computer via a USB port, the debugger will automatically connect to the correct port.

Some emulator drivers support multiple emulators connected to the same host computer. Each emulator requires its own instance of IAR Embedded Workbench and each instance must identify its emulator. To identify an emulator, click the browse button to display a list of all detected emulators. To identify a connection, click the port in the list and the Mode LED on the attached emulator will light up.

### **Debug protocol**

Determines the debug interface to use:

#### **Automatic selection**

Selects the debug interface automatically. (If **Connection** is set to `Automatic`, C-SPY correctly determines which interface to use.)

#### **Manual selection**

**Spy-Bi-Wire** to select the 2-wire JTAG (Spy-Bi-Wire) interface. Works with emulators from Elprotronic, Olimex, and Texas Instruments that connect via USB.

### **Disable memory cache**

Disables the memory cache in the FET debugger.

### **Jtag speed**

Sets the JTAG communication speed. Choose between **Fast**, **Medium**, and **Slow**.

### **Target VCC**

Specify the voltage provided by the USB interface:

#### **Override default**

Overrides the default voltage. To see what the default voltage is, see *Device Information window*, page 56.

#### **Target VCC**

Specify the voltage with one decimal's precision in the range 1.0–4.0 V. This option can only be used with a USB connection.

#### **Settling time**

Specify a delay that will be used between switching on the target VCC and starting the identification of the MSP430 device.

### **Enable ULP/LPMx.5 debug**

Enables debugging of applications that use the LPMx5 low-power mode.

## Download

By default, C-SPY downloads the application to RAM or flash when a debug session starts. The **Download** options let you modify the behavior of the download.

The screenshot shows a dialog box titled "Download" with the following options:

- Verify download
- Allow erase/write access to locked flash memory
- Allow erase/write access to BSL flash memory
- External code download

Under the "Flash erase" section, there are radio buttons for:

- Erase main memory
- Erase main and Information memory
- Retain unchanged memory
  - Compare with image on target
  - Compare with image cached on PC
- Erase main and Information memory inc. IP PROTECTED area

At the bottom, there is a "JTAG password:" label and an empty text input field.

### Verify download

Verifies that the downloaded code image can be read back from target memory with the correct contents.

### Allow erase/write access to locked flash memory

Enables erase/write access to Info Segment A. This option can only be used with devices that have the Info Segment A memory.

### Allow erase/write access to BSL flash memory

Enables erase/write access to BSL flash memory. This option can only be used with MSP430F5xx devices that have BSL flash memory.

### External code download

Saves user code to external SPI memory.

### Erase main memory

Erases only the main flash memory before download. The Information memory is not erased.

### Erase main and Information memory

Erases both flash memories—main and Information memory—before download.

### Retain unchanged memory

Reads the main and Information memories into a buffer. Only the flash segments that are needed are erased.

### Compare with image on target

Compares the data that is to be written into a segment with the image on the target. If the data matches the image, the data on the target is left as is, and nothing is downloaded. The new data effectively replaces the old data, and unchanged old data is retained.

### Compare with image cached on PC

Compares the data that is to be written into a segment with the image that is cached on the host computer.

### Erase main and Information memory inc. IP PROTECTED area

Erases the main and Information flash memories, including the IP protected area before download.

### JTAG password

If a JTAG device is password-protected, supply the needed password here.

## Breakpoints

The **Breakpoints** options control the use of breakpoints.

The screenshot shows a dialog box titled "Breakpoints". It contains two sections: "Software breakpoint" and "System breakpoints on".

- Software breakpoint:**
  - Use software breakpoints
  - Emulated breakpoints
    - Use only emulated breakpoints
  - Virtual breakpoints
- System breakpoints on:**
  - exit
  - putchar
  - getchar

### Use software breakpoints

Allows C-SPY to use software breakpoints when all available hardware breakpoints have been used. Choose between:

#### Emulated breakpoints

Makes C-SPY use emulated breakpoints: the instruction where the breakpoint is set will be replaced by a special instruction that the debugger recognizes.

#### Use only emulated breakpoints

C-SPY will use only emulated breakpoints.

#### Virtual breakpoints

Makes C-SPY use virtual breakpoints.

For information, see *Breakpoints in the C-SPY FET debugger driver*, page 106.

### System breakpoints on

Controls the use of system breakpoints in the CLIB runtime environment. If the C-SPY Terminal I/O window is not required or if you do not need a breakpoint on the `exit` label, you can save hardware breakpoints by not reserving system breakpoints. Select or deselect the options **exit**, **putchar**, and **getchar** respectively, if you want, or do not want, C-SPY to use system breakpoints for these. For more information, see *Breakpoint consumers*, page 107.

In the DLIB runtime environment, C-SPY will always set a system breakpoint on the `__DebugBreak` label. You cannot disable this behavior.





# Additional information on C-SPY drivers

This chapter describes the additional menus and features provided by the C-SPY® drivers. You will also find some useful hints about resolving problems.

---

## Reference information on C-SPY driver menus

This section gives reference information on the menus specific to the C-SPY drivers. More specifically, this means:

- *Simulator menu*, page 402
- *Emulator menu*, page 404.

### **C-SPY driver**

Before you start the C-SPY debugger, you must first specify a C-SPY driver in the **Options** dialog box, using the option **Debugger>Setup>Driver**.

When you start a debug session, a menu specific to that C-SPY driver will appear on the menu bar, with commands specific to the driver.

When we in this guide write “choose *C-SPY driver*>” followed by a menu command, *C-SPY driver* refers to the menu. If the feature is supported by the driver, the command will be on the menu.

## Simulator menu

When you use the simulator driver, the **Simulator** menu is added to the menu bar.

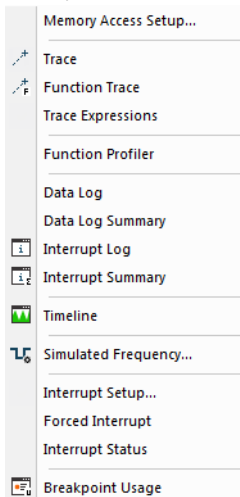

### Menu commands

These commands are available on the menu:

#### Memory Access Setup

Displays a dialog box to simulate memory access checking by specifying memory areas with different access types, see *Memory Access Setup dialog box*, page 169.



#### Trace

Opens a window which displays the collected trace data, see *Trace window*, page 180.



#### Function Trace

Opens a window which displays the trace data for function calls and function returns, see *Function Trace window*, page 184.

#### Trace Expressions

Opens a window where you can specify specific variables and expressions for which you want to collect trace data, see *Trace Expressions window*, page 187.

#### Function Profiler

Opens a window which shows timing information for the functions, see *Function Profiler window*, page 226.

**Data Log**

Opens a window which logs accesses to up to four different memory locations or areas, see *Data Log window*, page 205.

**Data Log Summary**

Opens a window which displays a summary of data accesses to specific memory location or areas, see *Data Log Summary window*, page 208.

**Interrupt Log**

Opens a window which displays the status of all defined interrupts, see *Interrupt Log window*, page 275.

**Interrupt Log Summary**

Opens a window which displays a summary of the status of all defined interrupts, see *Interrupt Log Summary window*, page 277.

**Timeline**

Opens a window which gives a graphical view of various kinds of information on a timeline, see *The application timeline*, page 191.

**Simulated Frequency**

Opens the **Simulated Frequency** dialog box where you can specify the simulator frequency used when the simulator displays time information, for example in the log windows. Note that this does not affect the speed of the simulator. For more information, see *Simulated Frequency dialog box*, page 408.

**Interrupt Setup**

Displays a dialog box where you can configure C-SPY interrupt simulation, see *Interrupt Setup dialog box*, page 269.

**Forced Interrupts**

Opens a window from where you can instantly trigger an interrupt, see *Forced Interrupt window*, page 272.

**Interrupt Status**

Opens a window from where you can instantly trigger an interrupt, see *Interrupt Status window*, page 273.

**Breakpoint Usage**

Displays a window which lists all active breakpoints, see *Breakpoint Usage window*, page 117.

## Emulator menu

When you are using the C-SPY FET Debugger driver, the **Emulator** menu is added to the menu bar.



These commands are available on the menu:

### Menu commands

These commands are available on the menu:

#### Power Log Setup

Opens a window; see *Power Log Setup window*, page 246.

#### Power Log

Opens a window; see *Power Log window*, page 248.

**State Log**

Opens a window; see *State Log window*, page 252.

**State Log Summary**

Opens a window; see *State Log Summary window*, page 254.

**Timeline**

Opens a window; see *Reference information on application timeline*, page 197.

**Data Sample Setup**

Opens a window; see *Data Sample Setup window*, page 215.

**Data Sample**

Opens a window; see *Data Sample window*, page 216.

**Sampled Graphs**

Opens a window; see *Sampled Graphs window*, page 211.

**Function Profiler**

Opens a window which shows timing information for the functions; see *Function Profiler window*, page 226.

**Release JTAG on Go**

Sets the JTAG drivers in tri-state so that the device is released from JTAG control—TEST pin is set to GND—when **Go** is activated.

**Leave Target Running**

Leaves the application running on the target hardware after the debug session is closed.



Any existing breakpoints will not be automatically removed. You might want to consider disabling all breakpoints before using this menu command.

If this menu command is not available, it is not supported by the C-SPY driver you are using.

**GIE on/off**

Clears the General Interrupt Enable bit (GIE) in the Processor Status register.

**Force Single Stepping**

Forces single step debugging.

**Force hardware RST/NMI**

Forces an RST/NMI clear reset when the Reset button is pressed.

**Resynchronize JTAG**

Regains control of the device.

It is not possible to resynchronize JTAG while the device is operating.

### Init New Device

Initializes the device according to the settings in the **Projects>Options>FET Debugger** category. The current program file is downloaded to the device memory, and the device is then reset. This command can be used to program multiple devices with the same program from within the same C-SPY session.

It is not possible to choose **Init New Device** while the device is operating, thus the command will be dimmed.



### State Storage Control

Opens the **State Storage Control** window, which lets you define the use of the state storage module; see *State Storage Control window*, page 294.



### State Storage Window

Opens the **State Storage** window which contains state storage information according to your definitions; see *State Storage window*, page 296.



### Sequencer Control

Opens the **Sequencer Control** window, which lets you define a state machine; see *Sequencer Control window*, page 303.

### Advanced Cycle Counter

Opens a window; see *Advanced Cycle Counter Control window*, page 287.



### Advanced>Clock Control

Lets you control the clocks on the device. Depending on the hardware support, either the **General Clock Control** dialog box or the **Extended Clock Control** dialog box is displayed; see *General Clock Control dialog box*, page 408 and *Extended Clock Control dialog box*, page 409, respectively.

### Advanced>Emulation Mode

Specifies the device to be emulated. The device must be reset (or reinitialized by using the menu command **Init New Device**) following a change to the emulation mode.

### Advanced>Memory Dump

Displays the **Memory Dump** dialog box, which lets you write device memory contents to a file; see *Memory Dump dialog box*, page 172.



### Advanced>Breakpoint Combiner

Displays the **Breakpoint combiner** dialog box, which lets you combine two already defined breakpoints; see *Breakpoint combiner dialog box*, page 133.

**User code erase (unlocks device)**

Overrides and clears FRAM memory protection and erases the Information and main memories. (Only available for FR2xx and FR4xx devices.)

**Secure - Blow JTAG Fuse**

Blows the fuse on the target device. After the fuse is blown, no communication with the device is possible.

Only available if you are using a USB-connected debug probe.

**Breakpoint Usage**

Opens a window which lists all active breakpoints; see *Breakpoint Usage window*, page 117.

**Device information**

Opens the Device Information window with information about the device used for debugging, see *Device Information window*, page 56.

**Connected device**

The name of the device used for debugging.

**Note:** Not all **Emulator>Advanced** submenu commands are available on all MSP430 devices.

---

## Reference information on the C-SPY simulator

This section gives additional reference information the C-SPY simulator, reference information not provided elsewhere in this documentation.

Reference information about:

- *Simulated Frequency dialog box*, page 408

## Simulated Frequency dialog box

The **Simulated Frequency** dialog box is available from the C-SPY driver menu.

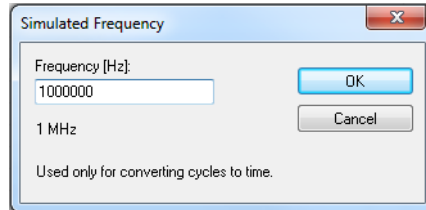

Use this dialog box to specify the simulator frequency used when the simulator displays time information.

### Requirements

The C-SPY simulator.

### Frequency

Specify the frequency in Hz.

---

## Reference information on the C-SPY FET Debugger driver

This section gives additional reference information on the C-SPY hardware debugger drivers, reference information not provided elsewhere in this documentation.

More specifically, this means:

- *General Clock Control dialog box*, page 408
- *Extended Clock Control dialog box*, page 409

## General Clock Control dialog box

The **General Clock Control** dialog box is available from the **Emulator** menu.

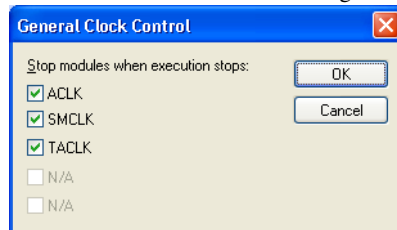

Use this dialog box to control the clocks of the device.



Select the clock modules you want to stop when the execution stops. The other clocks will keep running.

Which clock modules that are displayed depends on the available clocks on the connected device.

### Requirements

The C-SPY FET Debugger driver.

## Extended Clock Control dialog box

The **Extended Clock Control** dialog box is available from the **Emulator** menu.

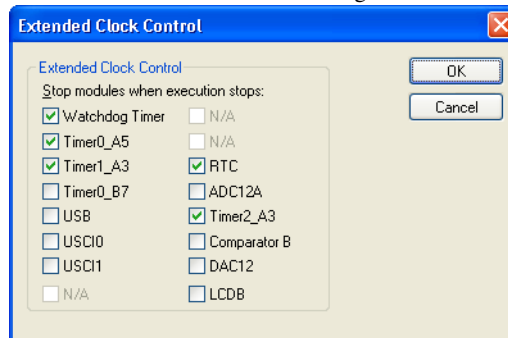

Use this dialog box for module level control over the clocks of the device.

Select the clock modules you want to stop when the execution stops. The other clocks will keep running.

Which clock modules that are displayed depends on the available clocks on the connected device.

### Requirements

The C-SPY FET Debugger driver.

## Resolving problems

These topics are covered:

- The device port pins do not work
- Write failure during load
- No contact with the target hardware

Debugging using the C-SPY hardware debugger systems requires interaction between many systems, independent from each other. For this reason, setting up this debug system can be a complex task. If something goes wrong, it might be difficult to locate the cause of the problem.

This section includes suggestions for resolving the most common problems that can occur when debugging with the C-SPY hardware debugger systems.

For problems concerning the operation of the evaluation board, refer to the documentation supplied with it, or contact your hardware distributor.

To troubleshoot the Flash Emulation Tool, see appendix A in the document *IAR Embedded Workbench Version 3+ for MSP430 User's Guide* at the Texas Instruments web site, [www.ti.com](http://www.ti.com). The document has the literature number *SLAU138AN*.

## THE DEVICE PORT PINS DO NOT WORK

On some MSP430 devices, the device port pins are shared with the JTAG pins that C-SPY uses to debug the device. Normally, C-SPY maintains the pins in JTAG mode so that the device can be debugged. During this time the port functionality of the shared pins is not available.

To release the JTAG pins:

Choose **Emulator>Release JTAG on Go** to set the JTAG drivers to tri-state and release the device from JTAG control (the TEST pin is set to GND) when **Go** is activated. Any active on-chip breakpoints are retained and the shared JTAG port pins revert to their port functions.

**Note:** Be aware of the following:

- The JTAG pins will only be released if there are N or fewer active breakpoints.
- When you measure the electrical current of the device, the JTAG control signals must be released, otherwise the device will be powered by the signals on the JTAG pins and the measurements will be incorrect.
- If you release the JTAG pins, C-SPY has no access to the device and cannot determine if an active breakpoint has been triggered. C-SPY must be manually told to stop the device, at which time the state of the device will be determined (that is, has a breakpoint been reached?).

## WRITE FAILURE DURING LOAD

There are several possible reasons for write failure during load. The most common is that your application has been incorrectly linked:

- Check the contents of your linker configuration file and make sure that your application has not been linked to the wrong address

- Check that you are using the correct linker configuration file.



#### To choose a device:

- 1 Choose **Project>Options**.
- 2 Select the **General Options** category.
- 3 Click the **Target** tab.
- 4 Choose the appropriate device from the **Device** drop-down list.

#### To override the default linker configuration file:

- 1 Choose **Project>Options**.
- 2 Select the **Linker** category.
- 3 Click the **Config** tab.
- 4 Choose the appropriate linker configuration file in the **Linker configuration file** area.

### NO CONTACT WITH THE TARGET HARDWARE

There are several possible reasons for C-SPY to fail to establish contact with the target hardware. Do this:

- Check the communication devices on your host computer
- Verify that the cable is properly plugged in and not damaged or of the wrong type
- Make sure that the evaluation board is supplied with sufficient power
- Check that the correct options for communication have been specified in the IAR Embedded Workbench IDE.

Examine the linker configuration file to make sure that the application has not been linked to the wrong address.



# A

Abort (Report Assert option) . . . . . 78  
 \_\_abortLaunch (C-SPY system macro) . . . . . 321  
 absolute location, specifying for a breakpoint . . . . . 133  
 Access type (Advanced Trigger breakpoints option) . . . . . 131  
 Access type (Edit Memory Access option) . . . . . 171  
 Access (Conditional breakpoints option) . . . . . 128  
 Access (Edit SFR option) . . . . . 168  
 Action (Advanced Trigger breakpoints option) . . . . . 131  
 Action (Conditional breakpoints option) . . . . . 129  
 Action (Sequencer option) . . . . . 303  
 Add to Watch Window (Symbolic Memory window context menu) . . . . . 154  
 Add (SFR Setup window context menu) . . . . . 166  
 Address Range (Find in Trace option) . . . . . 190  
 Address (Edit SFR option) . . . . . 168  
 Advanced Cycle Counter Control window . . . . . 287  
 Advanced Trigger breakpoints dialog box . . . . . 130  
 advanced trigger breakpoints, overview . . . . . 105  
 Advanced (Sequencer option) . . . . . 304  
 Advanced>Breakpoint Combiner (Emulator menu) . . . . . 406  
 Advanced>Clock Control (Emulator menu) . . . . . 406  
 Advanced>Emulation Mode (Emulator menu) . . . . . 406  
 Advanced>Memory Dump (Emulator menu) . . . . . 406  
 Allow erase/write access to locked  
 flash memory (C-SPY FET Debugger option) . . . . . 397  
 Allow erase/write access to  
 BSL flash memory (C-SPY FET Debugger option) . . . . . 397  
 --allow\_access\_to\_BSL (C-SPY command line option) . . . . . 368  
 --allow\_locked\_flash\_access  
 (C-SPY command line option) . . . . . 368  
 Ambiguous symbol (Resolve Symbol Ambiguity option) . . . . . 101  
 application flow, monitoring . . . . . 291  
 Applications (Advanced Cycle Counter option) . . . . . 287  
 application, built outside the IDE . . . . . 46  
 assembler labels, viewing . . . . . 84  
 assembler source code, fine-tuning . . . . . 221  
 assembler symbols, using in C-SPY expressions . . . . . 81  
 assembler variables, viewing . . . . . 84

assumptions, programming experience . . . . . 23  
 Auto Scroll (Sampled Graphs window context menu) . . . . . 213  
 Auto Scroll (Timeline window context menu) . . . . . 200, 203, 281  
 Auto window . . . . . 85  
 Autostep settings dialog box . . . . . 78  
 Autostep (Debug menu) . . . . . 52

# B

--attach\_to\_running\_target (C-SPY command line option) . . . . . 368  
 --backend (C-SPY command line option) . . . . . 369  
 backtrace information  
     viewing in Call Stack window . . . . . 71  
 batch mode, using C-SPY in . . . . . 363  
 Big Endian (Memory window context menu) . . . . . 148  
 blocks, in C-SPY macros . . . . . 315  
 bold style, in this guide . . . . . 28  
 Break At (Advanced Trigger breakpoints option) . . . . . 130  
 Break At (Conditional breakpoints option) . . . . . 127  
 Break on Throw (Debug menu) . . . . . 52  
 Break on Uncaught Exception (Debug menu) . . . . . 52  
 Break (Debug menu) . . . . . 51  
 Breakpoint combiner dialog box . . . . . 133  
 breakpoint condition, example . . . . . 112–113  
 Breakpoint Usage window . . . . . 117  
 Breakpoint Usage (Emulator menu) . . . . . 407  
 breakpoints  
     advanced trigger . . . . . 130  
     code, example . . . . . 341  
     conditional . . . . . 127  
         using . . . . . 292  
     connecting a C-SPY macro . . . . . 310  
     consumers of . . . . . 107  
     data . . . . . 121  
     data log . . . . . 123  
     description of . . . . . 103  
     disabling used by Stack window . . . . . 108  
     emulated, configuring . . . . . 399  
     icons for in the IDE . . . . . 106

in Memory window	111
listing all	117
range	125
reasons for using	103
setting	
in memory window	111
using system macros	111
using the dialog box	109
toggling	109
types of	104
useful tips	112
virtual, configuring	399
Breakpoints dialog box	
Advanced Trigger	130
Code	118
Conditional	127
Data	121
Data Log	123
Immediate	124
Log	119
Range	125
Trace Start	185
Trace Stop	186
Breakpoints window	115
Breakpoints (FET debugger options)	398
Browse (Trace toolbar)	181
byte order, setting in Memory window	147

## C

C function information, in C-SPY	65
C symbols, using in C-SPY expressions	81
C variables, using in C-SPY expressions	80
call chain, displaying in C-SPY	65
Call stack information	65
Call Stack window	71
for backtrace information	65
Call Stack (Timeline window context menu)	200
<code>__cancelAllInterrupts</code> (C-SPY system macro)	322

<code>__cancelInterrupt</code> (C-SPY system macro)	322
Check for word access on odd address (C-SPY simulator option)	394
Clear All (Debug Log window context menu)	76
Clear Group (Registers User Groups Setup window context menu)	163
Clear Group (Registers User Groups Setup window context menu)	163
Clear trace data (Trace toolbar)	181
Clear (Advanced Cycle Counter option)	289
Clear (Interrupt Log window context menu)	253, 256
Clear (Power Log window context menu)	249
<code>__clearBreak</code> (C-SPY system macro)	323
CLIB	
consuming breakpoints	108
library reference information for	27
naming convention	29
clock frequency, simulated	408
<code>__closeFile</code> (C-SPY system macro)	323
code breakpoints	
overview	104
toggling	109
Code Coverage window	232
Code Coverage (Disassembly window context menu)	69
<code>--code_coverage_file</code> (C-SPY command line option)	370
code, covering execution of	232
command line options	367
typographic convention	28
command prompt icon, in this guide	28
computer style, typographic convention	27
Condition (Conditional breakpoints option)	129
conditional breakpoints	
overview	106
triggering state storage	292
Conditional breakpoints dialog box	127
conditional statements, in C-SPY macros	314
<code>--connection</code> (C-SPY command line option)	369
Connection (C-SPY FET Debugger option)	395
context menu, in windows	83
conventions, used in this guide	27

- Copy Window Contents (Disassembly window context menu) . . . . . 71
  - Copy (Debug Log window context menu) . . . . . 76
  - copyright notice . . . . . 2
  - CPU cycles, counting . . . . . 284, 286
  - cspybat . . . . . 363
    - reading options from file (-f) . . . . . 376
  - current position, in C-SPY Disassembly window . . . . . 68
  - Current state (Sequencer option). . . . . 304
  - cursor, in C-SPY Disassembly window . . . . . 68
  - Cycle counter values (Advanced Cycle Counter option). . 288
  - cycles (C-SPY command line option) . . . . . 370
  - C-SPY
    - batch mode, using in . . . . . 363
    - debugger systems, overview of . . . . . 37
    - environment overview . . . . . 33
    - plugin modules, loading. . . . . 45
    - setting up . . . . . 43–44
    - starting the debugger . . . . . 45
  - C-SPY drivers
    - differences between drivers . . . . . 39
    - overview . . . . . 39
    - specifying . . . . . 390
    - types of . . . . . 38
  - C-SPY expressions . . . . . 80
    - evaluating, using Macro Quicklaunch window . . . . . 361
    - evaluating, using Quick Watch window. . . . . 97
    - in C-SPY macros . . . . . 314
    - Tooltip watch, using . . . . . 79
    - Watch window, using. . . . . 79
  - C-SPY hardware debugger driver
    - extending functionality of . . . . . 50
  - C-SPY macros
    - blocks. . . . . 315
    - conditional statements . . . . . 314
    - C-SPY expressions . . . . . 314
    - examples . . . . . 307
      - checking status of register. . . . . 309
      - creating a log macro . . . . . 310
    - executing . . . . . 307
      - connecting to a breakpoint . . . . . 310
      - using Quick Watch . . . . . 309
      - using setup macro and setup file . . . . . 309
    - functions . . . . . 82, 312
    - keywords . . . . . 312–313, 315
    - loop statements . . . . . 315
    - macro statements . . . . . 314
    - parameters . . . . . 313
    - setup macro file . . . . . 306
      - executing. . . . . 309
    - setup macro functions . . . . . 306
      - summary . . . . . 317
    - system macros, summary of . . . . . 319
    - using . . . . . 305
    - variables. . . . . 82, 312
  - C-SPY options
    - Breakpoints . . . . . 398
    - Download . . . . . 397
    - Extra Options. . . . . 393
    - Images . . . . . 391
    - Plugins. . . . . 392
    - Setup . . . . . 390
    - Setup (FET) . . . . . 395
  - C-SPYLink . . . . . 38
  - C-STAT for static analysis, documentation for. . . . . 26
  - C++ terminology. . . . . 27
- ## D
- d (C-SPY command line option) . . . . . 371
  - data breakpoints, overview . . . . . 104
  - Data Coverage (Memory window context menu) . . . . . 148
  - data coverage, in Memory window . . . . . 146
  - data log breakpoints, overview . . . . . 105
  - Data Log Summary window . . . . . 208
  - Data Log Summary (Simulator menu) . . . . . 403
  - Data Log window . . . . . 205
  - Data Log (Simulator menu) . . . . . 403

Data Log (Timeline window context menu) . . . . .	204
Data Sample Setup window . . . . .	215
Data Sample window . . . . .	216
Data Sample (Sampled Graphs window context menu) . . . . .	213
ddf (filename extension), selecting a file . . . . .	44
Debug Log window . . . . .	75
Debug menu (C-SPY main window). . . . .	51
Debug protocol (C-SPY FET Debugger option) . . . . .	396
Debug (Report Assert option) . . . . .	78
--debugfile (cspybat option) . . . . .	371
debugger concepts, definitions of . . . . .	36
debugger drivers	
FET Debugger . . . . .	40
simulator . . . . .	40
debugger drivers. <i>See</i> C-SPY drivers	
Debugger Macros window . . . . .	359
debugger system overview . . . . .	37
debugging projects	
externally built applications . . . . .	46
loading multiple images . . . . .	47
debugging, RTOS awareness . . . . .	35
__delay (C-SPY system macro) . . . . .	323
Delay (Autostep Settings option) . . . . .	78
Delete (Breakpoints window context menu) . . . . .	116
Delete (SFR Setup window context menu) . . . . .	166
Delete/revert All Custom SFRs (SFR Setup window context menu) . . . . .	166
--derivative (C-SPY command line option). . . . .	372
Description (Edit Interrupt option) . . . . .	271
description (interrupt property). . . . .	271
Device description file (debugger option). . . . .	391
device description files . . . . .	44
definition of . . . . .	48
memory zones . . . . .	139
modifying . . . . .	48
register zone. . . . .	139
specifying interrupts . . . . .	334
Device Information window . . . . .	56
Device information (Emulator menu) . . . . .	407
Device Support Module . . . . .	50

Disable All (Breakpoints window context menu) . . . . .	116
Disable memory cache (C-SPY FET Debugger option) . . . . .	396
Disable (Breakpoints window context menu) . . . . .	116
__disableInterrupts (C-SPY system macro) . . . . .	324
--disable_interrupts (C-SPY command line option) . . . . .	372
--disable_memory_cache (C-SPY command line option) . . . . .	372
Disassembly window . . . . .	67
context menu . . . . .	69
disclaimer . . . . .	2
DLIB	
consuming breakpoints . . . . .	108
naming convention. . . . .	29
DMA load, measuring. . . . .	284
do (macro statement) . . . . .	315
document conventions . . . . .	27
documentation	
overview of guides. . . . .	25
overview of this guide . . . . .	24
this guide . . . . .	23
Download (FET debugger options). . . . .	397
--download_only (C-SPY command line option) . . . . .	372
Driver (debugger option) . . . . .	390
__driverType (C-SPY system macro). . . . .	324

## E

Edit Expressions (Trace toolbar). . . . .	181
Edit Interrupt dialog box. . . . .	271
Edit Memory Access dialog box . . . . .	171
Edit Memory Range dialog box . . . . .	167
Edit Settings (Trace toolbar). . . . .	181
Edit (Breakpoints window context menu). . . . .	116
Edit (SFR Setup window context menu). . . . .	166
edition, of this guide . . . . .	2
--eem (C-SPY command line option) . . . . .	373
emulated breakpoints, configuring . . . . .	399
Emulator menu (reference information) . . . . .	404
Enable All (Breakpoints window context menu) . . . . .	116
Enable interrupt simulation (Interrupt Setup option). . . . .	269



- Enable Log File (Log File option) . . . . . 77
  - Enable ULP/LPMx.5 debug (C-SPY FET Debugger option) . . . . . 396
  - Enable (Breakpoints window context menu) . . . . . 116
  - Enable (Interrupt Log window context menu) . . . . . 253, 256
  - Enable (Power Log window context menu) . . . . . 249
  - Enable (Sampled Graphs window context menu) . . . . . 213
  - Enable (Timeline window context menu) . . . . . 200–201, 204
  - \_\_enableInterrupts (C-SPY system macro) . . . . . 325
  - Enable/Disable Breakpoint (Call Stack window context menu) . . . . . 73
  - Enable/Disable Breakpoint (Disassembly window context menu) . . . . . 70
  - Enable/Disable (Trace toolbar) . . . . . 181
  - End address (Memory Save option) . . . . . 149
  - endianness. *See* byte order
  - Enter Location dialog box . . . . . 132
  - Erase main and Information memory inc. IP PROTECTED area (C-SPY FET Debugger option) . . . . . 398
  - Erase main and Information memory (C-SPY FET Debugger option) . . . . . 397
  - Erase main memory (C-SPY FET Debugger option) . . . . . 397
  - erase\_exclude (C-SPY command line option) . . . . . 374
  - erase\_ip\_protected (C-SPY command line option) . . . . . 374
  - erase\_main (C-SPY command line option) . . . . . 374
  - erase\_main\_and\_info (C-SPY command line option) . . . . . 375
  - erase\_retain\_file (C-SPY command line option) . . . . . 375
  - erase\_retain\_target (C-SPY command line option) . . . . . 375
  - \_\_evaluate (C-SPY system macro) . . . . . 325
  - Evaluate Now (Macro Quicklaunch window context menu) . . . . . 362
  - examples
    - C-SPY macros . . . . . 307
    - interrupts
      - interrupt logging . . . . . 268
      - timer . . . . . 266
    - macros
      - checking status of register . . . . . 309
      - creating a log macro . . . . . 310
      - using Quick Watch . . . . . 309
    - performing tasks and continue execution . . . . . 113
    - tracing incorrect function arguments . . . . . 112
  - execUserExecutionStarted (C-SPY setup macro) . . . . . 318
  - execUserExecutionStopped (C-SPY setup macro) . . . . . 318
  - execUserExit (C-SPY setup macro) . . . . . 319
  - execUserPreload (C-SPY setup macro) . . . . . 317
  - execUserPreReset (C-SPY setup macro) . . . . . 319
  - execUserReset (C-SPY setup macro) . . . . . 319
  - execUserSetup (C-SPY setup macro) . . . . . 318
  - executed code, covering . . . . . 232
  - execution history, tracing . . . . . 180
  - execution, stopping using the sequencer . . . . . 299
  - expressions. *See* C-SPY expressions
  - Extended Clock Control dialog box . . . . . 409
  - extended command line file, for cspybat . . . . . 376
  - External code download (C-SPY FET option) . . . . . 397
  - extra cycle counter . . . . . 283
  - Extra Options, for C-SPY . . . . . 393
- ## F
- f (cspybat option) . . . . . 376
  - FET Debugger (C-SPY driver)
    - communication . . . . . 410
    - hardware installation . . . . . 42
  - File format (Memory Save option) . . . . . 149
  - file types
    - device description, specifying in IDE . . . . . 44
    - macro . . . . . 44, 391
  - filename extensions
    - ddf, selecting device description file . . . . . 44
    - mac, using macro file . . . . . 44
    - sfr, register definitions for C-SPY . . . . . 161
  - Filename (Memory Restore option) . . . . . 150
  - Filename (Memory Save option) . . . . . 150
  - Fill dialog box . . . . . 151
  - \_\_writeMemory8 (C-SPY system macro) . . . . . 326
  - \_\_writeMemory16 (C-SPY system macro) . . . . . 326
  - \_\_writeMemory32 (C-SPY system macro) . . . . . 327

Find in Trace dialog box . . . . .	189
Find in Trace window . . . . .	190
Find in Trace (Disassembly window context menu) . . . . .	71
Find (Memory window context menu) . . . . .	148
Find (Trace toolbar) . . . . .	181
first activation time (interrupt property) definition of . . . . .	262
First activation (Edit Interrupt option) . . . . .	271
flash memory, load library module to . . . . .	329
flash memory, single-stepping in C-SPY emulator . . . . .	62
__fmessage (C-SPY macro keyword) . . . . .	315
for (macro statement) . . . . .	315
Force hardware RST/NMI (Emulator menu) . . . . .	405
Force Single Stepping (Emulator menu) . . . . .	405
Force (Forced Interrupt window context menu) . . . . .	273
Forced Interrupt window . . . . .	272
Forced Interrupts (Simulator menu) . . . . .	403
Format (Registers User Groups Setup window context menu) . . . . .	163
Format (Registers window context menu) . . . . .	161
formats, C-SPY input . . . . .	35
Function Profiler window . . . . .	226
Function Profiler (Simulator menu) . . . . .	402
Function Trace window . . . . .	184
functions C-SPY running to when starting . . . . .	44, 390
most time spent in, locating . . . . .	221
--function_profiling (cspybat option) . . . . .	376
fuse, blowing on the target device. . . . .	407

## G

General Clock Control dialog box . . . . .	408
GIE on/off (Emulator menu) . . . . .	405
Go to Source (Breakpoints window context menu) . . . . .	116
Go to Source (Call Stack window context menu) . . . . .	72
Go To Source (Timeline window context menu) . . . . .	201, 205, 282
Go (Debug menu) . . . . .	51, 64

## H

hardware setup, power consumption because of . . . . .	241
--hardware_multiplier (C-SPY command line option) . . . . .	377
highlighting, in C-SPY . . . . .	64
Hold time (Edit Interrupt option) . . . . .	272
hold time (interrupt property), definition of . . . . .	263
--hwmult_type (C-SPY command line option) . . . . .	377

## I

icons, in this guide . . . . .	28
if else (macro statement) . . . . .	314
if (macro statement) . . . . .	314
Ignore (Report Assert option) . . . . .	78
Images window . . . . .	54
Images, loading multiple. . . . .	391
immediate breakpoints, overview . . . . .	105
Include (Log File option) . . . . .	77
Init New Device (Emulator menu) . . . . .	406
input formats, C-SPY . . . . .	35
Input Mode dialog box . . . . .	74
input, special characters in Terminal I/O window . . . . .	74
installation directory . . . . .	27
Instruction Profiling (Disassembly window context menu) . . . . .	70
Intel-extended, C-SPY input format . . . . .	35
Intel-extended, C-SPY output format . . . . .	38
Intel-Standard, C-SPY input format . . . . .	35
interference, power consumption because of . . . . .	241
interrupt handling, power consumption during . . . . .	240
Interrupt Log Summary window . . . . .	254, 277
Interrupt Log window . . . . .	275
Interrupt Setup dialog box . . . . .	269
Interrupt Setup (Simulator menu) . . . . .	403
Interrupt Status window . . . . .	273
interrupt system, using device description file . . . . .	265
Interrupt (Edit Interrupt option) . . . . .	271
Interrupt (Timeline window context menu) . . . . .	282

- interrupts
    - adapting C-SPY system for target hardware . . . . . 265
    - simulated, introduction to . . . . . 261
    - timer, example . . . . . 266
    - using system macros . . . . . 264
  - `__isBatchMode` (C-SPY system macro) . . . . . 328
  - italic style, in this guide . . . . . 27–28
- ## J
- JTAG password (C-SPY FET Debugger option) . . . . . 398
  - JTAG pins, shared with port pins . . . . . 410
  - JTAG speed (C-SPY FET Debugger option) . . . . . 396
  - `--jtag_speed` (C-SPY command line option) . . . . . 378
- ## L
- labels (assembler), viewing . . . . . 84
  - Leave Target Running (Emulator menu) . . . . . 405
  - `--leave_target_running` (C-SPY command line option) . . . . . 378
  - Length (Fill option) . . . . . 151
  - library functions
    - C-SPY support for using, plugin module . . . . . 381
    - online help for . . . . . 26
  - lightbulb icon, in this guide . . . . . 28
  - linker options
    - typographic convention . . . . . 28
    - consuming breakpoints . . . . . 108
  - Little Endian (Memory window context menu) . . . . . 147
  - Live Watch window . . . . . 92
  - `__loadImage` (C-SPY system macro) . . . . . 329
  - loading multiple debug files, list currently loaded . . . . . 54
  - loading multiple images . . . . . 47
  - Locals window . . . . . 87
  - log breakpoints, overview . . . . . 104
  - Log File dialog box . . . . . 77
  - Logging>Set Log file (Debug menu) . . . . . 53
  - Logging>Set Terminal I/O Log file (Debug menu) . . . . . 53
  - loop statements, in C-SPY macros . . . . . 315
  - low-power mode, power consumption during . . . . . 238
  - `--lpt1` (C-SPY command line option) . . . . . 379
  - `--lpt2` (C-SPY command line option) . . . . . 379
  - `--lpt3` (C-SPY command line option) . . . . . 379
- ## M
- mac (filename extension), using a macro file . . . . . 44
  - `--macro` (C-SPY command line option) . . . . . 379
  - macro files, specifying . . . . . 44, 391
  - Macro Quicklaunch window . . . . . 361
  - Macro Registration window . . . . . 357
  - macro statements . . . . . 314
  - macros
    - executing . . . . . 307
    - using . . . . . 305
  - `--macro-param` (C-SPY command line option) . . . . . 380
  - main function, C-SPY running to when starting . . . . . 44, 390
  - `--mapu` (C-SPY command line option) . . . . . 380
  - Mask (Advanced Trigger breakpoints option) . . . . . 131
  - Mask (Conditional breakpoints option) . . . . . 129
  - Memory access checking (Memory Access Setup option) 170
  - Memory Access Setup dialog box . . . . . 169
  - Memory Access Setup (Simulator menu) . . . . . 402
  - memory contents, writing to a file . . . . . 172
  - Memory Dump dialog box . . . . . 172
  - Memory Fill (Memory window context menu) . . . . . 148
  - memory map . . . . . 169
  - Memory Restore dialog box . . . . . 150
  - Memory Restore (Memory window context menu) . . . . . 148
  - Memory Save dialog box . . . . . 149
  - Memory Save (Memory window context menu) . . . . . 148
  - Memory window . . . . . 145
  - memory zones . . . . . 138
    - in device description file . . . . . 139
  - `__memoryRestore` (C-SPY system macro) . . . . . 330
  - `__memorySave` (C-SPY system macro) . . . . . 330
  - Memory>Restore (Debug menu) . . . . . 53
  - Memory>Save (Debug menu) . . . . . 53

menu bar, C-SPY-specific	50
__message (C-SPY macro keyword)	315
__messageBoxYesCancel (C-SPY system macro)	331
__messageBoxYesNo (C-SPY system macro)	332
Messages window, amount of output	76
migration, from earlier IAR compilers	26
MISRA C	
documentation	26
Mixed Mode (Disassembly window context menu)	71
Mode (Advanced Cycle Counter option)	288
Motorola, C-SPY input format	35
Motorola, C-SPY output format	38
Move to PC (Disassembly window context menu)	69

## N

Name (Edit SFR option)	167
naming conventions	28
Navigate (Sampled Graphs window context menu)	212
Navigate (Timeline window context menu)	200, 203, 281
New Breakpoint (Breakpoints window context menu)	116
Next Statement (Debug menu)	52
Next Symbol (Symbolic Memory window context menu)	154

## O

--odd_word_check (C-SPY command line option)	380
Open Setup Window (Power Log window context menu)	250
Open User Groups Setup Window (Registers window context menu)	162
__openFile (C-SPY system macro)	332
Operation (Fill option)	151
Operator (Advanced Trigger breakpoints option)	131
Operator (Conditional breakpoints option)	128
operators, sizeof in C-SPY	82
optimizations, effects on variables	82
options	
in the IDE	389
on the command line	367, 393

Options (Stack window context menu)	158
__orderInterrupt (C-SPY system macro)	334
Originator (debugger option)	392

## P

-p (C-SPY command line option)	381
__param (C-SPY macro keyword)	313
parameters	
tracing incorrect values of	65
typographic convention	27
part number, of this guide	2
peripheral units	
debugging power consumption for	235
detecting mistakenly unattended	239
detecting unattended	239
device-specific	48
displayed in Register window	138
in an event-driven system	240
in C-SPY expressions	81
initializing using setup macros	306
Please select one symbol	
(Resolve Symbol Ambiguity option)	102
--plugin (C-SPY command line option)	381
plugin modules (C-SPY)	38
loading	45
Plugins (C-SPY options)	392
__popSimulatorInterruptExecutingStack (C-SPY system macro)	335
pop-up menu. <i>See</i> context menu	
--port (C-SPY command line option)	382
port pins, shared with JTAG pins	410
power consumption, measuring	222, 235
Power graph in Timeline window	251
Power Log window	248
power sampling	222
Power Setup window	246
prerequisites, programming experience	23
Previous Symbol (Symbolic Memory window context menu)	154

probability (interrupt property) . . . . . 272  
 definition of . . . . . 262  
 Probability % (Edit Interrupt option) . . . . . 272  
 Profile Selection (Timeline window context menu) . . . . . 201  
 profiling  
 analyzing data . . . . . 224  
 on function level . . . . . 223  
 on instruction level. . . . . 225  
 using MSP430 advanced cycle counter . . . . . 285  
 profiling information, on functions and instructions . . . . . 221  
 profiling sources  
 trace (calls) . . . . . 222, 228  
 trace (flat) . . . . . 222, 228  
 program execution  
 breaking. . . . . 104–105  
 in C-SPY . . . . . 59  
 program flow, monitoring. . . . . 291  
 program states, monitoring . . . . . 291  
 programming experience . . . . . 23  
 program. *See* application  
 projects, for debugging externally built applications. . . . . 46  
 --protocol (C-SPY command line option) . . . . . 382  
 publication date, of this guide . . . . . 2

## Q

Quick Watch window . . . . . 97  
 executing C-SPY macros . . . . . 309

## R

Range breakpoints dialog box . . . . . 125  
 range breakpoints, overview . . . . . 105  
 Range for (Viewing Range option) . . . . . 218  
 Reaction trigger (Advanced Cycle Counter option) . . . . . 290  
 \_\_readFile (C-SPY system macro) . . . . . 335  
 \_\_readFileByte (C-SPY system macro) . . . . . 336  
 reading guidelines . . . . . 23  
 \_\_readMemoryByte (C-SPY system macro) . . . . . 336

\_\_readMemory8 (C-SPY system macro) . . . . . 336  
 \_\_readMemory16 (C-SPY system macro) . . . . . 337  
 \_\_readMemory32 (C-SPY system macro) . . . . . 337  
 reference information, typographic convention. . . . . 28  
 Refresh (Debug menu) . . . . . 53  
 register groups . . . . . 138  
 predefined, enabling. . . . . 159  
 Register User Groups Setup window . . . . . 162  
 registered trademarks . . . . . 2  
 \_\_registerMacroFile (C-SPY system macro) . . . . . 338  
 Registers window . . . . . 159  
 registers, displayed in Registers window . . . . . 159  
 Release JTAG on Go (Emulator menu) . . . . . 405  
 Remove All (Macro Quicklaunch window context menu) . . . . . 362  
 Remove (Macro Quicklaunch window context menu) . . . . . 362  
 Remove (Registers User Groups Setup window context menu) . . . . . 163  
 Repeat interval (Edit Interrupt option) . . . . . 271  
 repeat interval (interrupt property), definition of . . . . . 262  
 Replace (Memory window context menu) . . . . . 148  
 Report Assert dialog box . . . . . 78  
 Reset Counter (Advanced Cycle Counter option) . . . . . 290  
 Reset States (Sequencer option) . . . . . 304  
 Reset Trigger (Sequencer option) . . . . . 304  
 Reset (Debug menu) . . . . . 51  
 \_\_resetFile (C-SPY system macro) . . . . . 338  
 Resolve Source Ambiguity dialog box . . . . . 134  
 Restore (Memory Restore option) . . . . . 150  
 Resynchronize JTAG (Emulator menu) . . . . . 405  
 Retain unchanged memory (C-SPY FET Debugger option) . . . . . 398  
 return (macro statement) . . . . . 315  
 ROM-monitor, definition of . . . . . 38  
 RTOS awareness debugging . . . . . 35  
 RTOS awareness (C-SPY plugin module) . . . . . 35  
 Run to Cursor (Call Stack window context menu) . . . . . 72  
 Run to Cursor (Debug menu) . . . . . 52  
 Run to Cursor (Disassembly window context menu) . . . . . 69  
 Run to Cursor, command for executing . . . . . 64

Run to (C-SPY option) . . . . . 44, 390

## S

Sampled Graphs window . . . . . 211  
Save Custom SFRs (SFR Setup window context menu) . . 167  
Save to File (Register User Groups  
Setup window context menu) . . . . . 163  
Save to File (Registers window context menu) . . . . . 162  
Save (Memory Save option) . . . . . 150  
Save (Trace toolbar) . . . . . 181  
Scale (Viewing Range option) . . . . . 219  
Secure - Blow JTAG Fuse (Emulator menu) . . . . . 407  
Select All (Debug Log window context menu) . . . . . 76  
Select Graphs (Sampled Graphs window context menu) . 214  
Select Graphs (Timeline window context menu) 201, 205, 282  
Select plugins to load (debugger option) . . . . . 392  
Sequencer Control window . . . . . 303  
Sequencer Control (Emulator menu) . . . . . 406  
sequencer, setting up . . . . . 300  
Set Data Breakpoint (Memory window context menu) . . 148  
Set Data Log  
Breakpoint (Memory window context menu) . . . . . 149  
Set Next Statement (Debug menu) . . . . . 52  
Set Next Statement (Disassembly window context menu) . 70  
\_\_setAdvancedTriggerBreak (C-SPY system macro) . . . 339  
\_\_setCodeBreak (C-SPY system macro) . . . . . 340  
\_\_setConditionalBreak (C-SPY system macro) . . . . . 341  
\_\_setDataBreak (C-SPY system macro) . . . . . 343  
\_\_setDataLogBreak (C-SPY system macro) . . . . . 344  
\_\_setLogBreak (C-SPY system macro) . . . . . 345  
\_\_setRangeBreak (C-SPY system macro) . . . . . 346  
\_\_setSimBreak (C-SPY system macro) . . . . . 347  
Settling time (C-SPY FET option) . . . . . 396  
--settlingtime (C-SPY command line option) . . . . . 383  
\_\_setTraceStartBreak (C-SPY system macro) . . . . . 348  
\_\_setTraceStopBreak (C-SPY system macro) . . . . . 349  
setup macro file, registering . . . . . 44

setup macro functions . . . . . 306  
    reserved names . . . . . 317  
Setup macros (debugger option) . . . . . 391  
Setup (C-SPY options) . . . . . 390  
Setup (FET debugger options) . . . . . 395  
--set\_exit\_breakpoint (C-SPY command line option) . . . 383  
--set\_getchar\_breakpoint (C-SPY command line option) . 383  
--set\_putchar\_breakpoint (C-SPY command line option) . 383  
SFR  
    using as assembler symbols . . . . . 81  
SFR Setup window . . . . . 164  
shortcut menu. *See* context menu  
Show all images (Images window context menu) . . . . . 55  
Show All (SFR Setup window context menu) . . . . . 166  
Show Arguments (Call Stack window context menu) . . . . 72  
Show Custom SFRs only (SFR Setup  
window context menu) . . . . . 166  
Show Cycles (Interrupt Log window context menu) . 253, 256  
Show Factory SFRs only (SFR Setup  
window context menu) . . . . . 166  
Show Numerical Value  
(Timeline window context menu) . . . . . 205, 214  
Show offsets (Stack window context menu) . . . . . 157  
Show only (Image window context menu) . . . . . 55  
Show Time (Interrupt Log window context menu) . . 253, 256  
Show variables (Stack window context menu) . . . . . 157  
--silent (C-SPY command line option) . . . . . 384  
Simulated Frequency dialog box . . . . . 408  
simulating interrupts, enabling/disabling . . . . . 269  
Simulator menu . . . . . 402  
simulator, introduction . . . . . 40  
Size (Edit SFR option) . . . . . 168  
Size (Sampled Graphs window context menu) . . . . . 214  
Size (Timeline window context menu) . . . . . 204  
sizeof . . . . . 82  
\_\_smessage (C-SPY macro keyword) . . . . . 315  
software delay, power consumption during . . . . . 238  
Solid Graph (Sampled Graphs window context menu) . . 214  
Solid Graph (Timeline window context menu) . . . . . 204  
\_\_sourcePosition (C-SPY system macro) . . . . . 350

- special function registers (SFR)
  - description files . . . . . 161
  - using as assembler symbols . . . . . 81
- Stack window . . . . . 155
- standard C, sizeof operator in C-SPY . . . . . 82
- Start address (Fill option) . . . . . 151
- Start address (Memory Save option) . . . . . 149
- Start (Advanced Cycle Counter option) . . . . . 289
- State Log window . . . . . 252
- state storage
  - setting up . . . . . 292
  - starting using the sequencer . . . . . 299
- State Storage Control window . . . . . 294
- State Storage Control (Emulator menu) . . . . . 406
- State Storage window . . . . . 296
- static analysis
  - documentation for . . . . . 26
- Statics window . . . . . 94
- stdin and stdout, redirecting to C-SPY window . . . . . 73
- Step Into (Debug menu) . . . . . 52
- Step Into, description . . . . . 61
- Step Out (Debug menu) . . . . . 52
- Step Out, description . . . . . 62
- Step Over (Debug menu) . . . . . 52
- Step Over, description . . . . . 61
- step points, definition of . . . . . 60
- Stop Debugging (Debug menu) . . . . . 52
- Stop (Advanced Cycle Counter option) . . . . . 289
- stopping execution using the sequencer . . . . . 299
- \_\_strFind (C-SPY system macro) . . . . . 350
- \_\_subString (C-SPY system macro) . . . . . 351
- Symbolic Memory window . . . . . 152
- Symbols window . . . . . 100
- symbols, using in C-SPY expressions . . . . . 80
- System breakpoints on (C-SPY FET Debugger option) . . 399
- Target VCC (C-SPY FET Debugger option) . . . . . 396
- \_\_targetDebuggerVersion (C-SPY system macro) . . . . . 351
- Terminal IO Log Files (Terminal IO Log Files option) . . . 75
- Terminal I/O Log Files dialog box . . . . . 74
- Terminal I/O window . . . . . 65, 73
- terminology . . . . . 27
- Text search (Find in Trace option) . . . . . 189
- TI msp430-txt, C-SPY input format . . . . . 35
- TI msp430-txt, C-SPY output format . . . . . 38
- Time Axis Unit (Timeline window context menu) . . 201, 205
- Time Axis Unit
  - (Timeline window context menu) . . . . . 282
- Timeline window . . . . . 198, 201, 257
  - power graph . . . . . 251
- timeout (C-SPY command line option) . . . . . 384
- timer interrupt, example . . . . . 266
- Toggle Breakpoint (Code) (Call
  - Stack window context menu) . . . . . 72
- Toggle Breakpoint (Code) (Disassembly
  - window context menu) . . . . . 70
- Toggle Breakpoint (Log) (Call
  - Stack window context menu) . . . . . 73
- Toggle Breakpoint (Log) (Disassembly
  - window context menu) . . . . . 70
- Toggle Breakpoint (Trace Start) (Call
  - Stack window context menu) . . . . . 73
- Toggle Breakpoint (Trace Start) (Disassembly
  - window context menu) . . . . . 70
- Toggle Breakpoint (Trace Stop) (Call
  - Stack window context menu) . . . . . 73
- Toggle Breakpoint (Trace Stop) (Disassembly
  - window context menu) . . . . . 70
- Toggle source (Trace toolbar) . . . . . 181
- \_\_toLower (C-SPY system macro) . . . . . 352
- tools icon, in this guide . . . . . 28
- \_\_toString (C-SPY system macro) . . . . . 352
- \_\_toUpper (C-SPY system macro) . . . . . 353
- trace . . . . . 177, 191
- Trace Expressions window . . . . . 187
- trace start and stop breakpoints, overview . . . . . 104

## T

target system, definition of . . . . . 37

Trace Start breakpoints dialog box	185
Trace Stop breakpoints dialog box	186
Trace window	180
trace (calls), profiling source	222, 228
trace (flat), profiling source	222, 228
trace, in Timeline window	198, 201, 251, 257
trace, state storage being variant of	291
trademarks	2
Type (Advanced Trigger breakpoints option)	130
Type (Conditional breakpoints option)	128
typographic conventions	27

## U

UBROF	35
Unavailable, C-SPY message	83
Universal Binary Relocatable Object Format. <i>See</i> UBROF	
__unloadImage(C-SPY system macro)	353
Use command line options (debugger option)	393
Use Extra Images (debugger option)	391
Use manual ranges (Memory Access Setup option)	170
Use only emulated breakpoints (FET Debugger option)	211–212, 399
Use ranges based on (Memory Access Setup option)	169
Use software breakpoints (C-SPY FET Debugger option)	399
user application, definition of	37
--use_emulated_breakpoints (C-SPY command line option)	384
--use_virtual_breakpoints (C-SPY command line option)	385

## V

Value (Advanced Trigger breakpoints option)	131
Value (Fill option)	151
__var (C-SPY macro keyword)	312
variables	
effects of optimizations	82
information, limitation on	82
using in C-SPY expressions	80

variance (interrupt property), definition of	263
Variance % (Edit Interrupt option)	272
--vccvoltage (C-SPY command line option)	385
Verify download (debugger option)	397
--verify_all (C-SPY command line option)	385
version number	
of this guide	2
View Group (Registers window context menu)	161
View User Group (Registers window context menu)	161
Viewing Range dialog box	218
Viewing Range (Sampled Graphs window context menu)	214
Viewing Range (Timeline window context menu)	204
virtual breakpoints	
configuring	399
visualSTATE, C-SPY plugin module for	38

## W

waiting for device, power consumption during	238
warnings icon, in this guide	28
Watch window	89
using	79
web sites, recommended	27
while (macro statement)	315
windows, specific to C-SPY	53
With I/O emulation modules (linker option), using	73
__writeFile (C-SPY system macro)	354
__writeFileByte (C-SPY system macro)	354
__writeMemoryByte (C-SPY system macro)	355
__writeMemory8 (C-SPY system macro)	355
__writeMemory16 (C-SPY system macro)	355
__writeMemory32 (C-SPY system macro)	356

## Z

zone	
defined in device description file	139
in C-SPY	138
part of an absolute address	133



Zone (Edit SFR option) . . . . .	168
Zone (Memory Save option) . . . . .	149–150
Zoom (Sampled Graphs window context menu) . . . . .	213
Zoom (Timeline window context menu) . . . . .	200, 204, 281

## Symbols

__abortLaunch (C-SPY system macro) . . . . .	321
__cancelAllInterrupts (C-SPY system macro) . . . . .	322
__cancelInterrupt (C-SPY system macro) . . . . .	322
__clearBreak (C-SPY system macro) . . . . .	323
__closeFile (C-SPY system macro) . . . . .	323
__delay (C-SPY system macro) . . . . .	323
__disableInterrupts (C-SPY system macro) . . . . .	324
__driverType (C-SPY system macro) . . . . .	324
__enableInterrupts (C-SPY system macro) . . . . .	325
__evaluate (C-SPY system macro) . . . . .	325
__fillMemory8 (C-SPY system macro) . . . . .	326
__fillMemory16 (C-SPY system macro) . . . . .	326
__fillMemory32 (C-SPY system macro) . . . . .	327
__fmessage (C-SPY macro keyword) . . . . .	315
__isBatchMode (C-SPY system macro) . . . . .	328
__loadImage (C-SPY system macro) . . . . .	329
__memoryRestore (C-SPY system macro) . . . . .	330
__memorySave (C-SPY system macro) . . . . .	330
__message (C-SPY macro keyword) . . . . .	315
__messageBoxYesCancel (C-SPY system macro) . . . . .	331
__messageBoxYesNo (C-SPY system macro) . . . . .	332
__openFile (C-SPY system macro) . . . . .	332
__orderInterrupt (C-SPY system macro) . . . . .	334
__param (C-SPY macro keyword) . . . . .	313
__popSimulatorInterruptExecutingStack (C-SPY system macro) . . . . .	335
__readFile (C-SPY system macro) . . . . .	335
__readFileByte (C-SPY system macro) . . . . .	336
__readMemoryByte (C-SPY system macro) . . . . .	336
__readMemory8 (C-SPY system macro) . . . . .	336
__readMemory16 (C-SPY system macro) . . . . .	337
__readMemory32 (C-SPY system macro) . . . . .	337

__registerMacroFile (C-SPY system macro) . . . . .	338
__resetFile (C-SPY system macro) . . . . .	338
__setAdvancedTriggerBreak (C-SPY system macro) . . . . .	339
__setCodeBreak (C-SPY system macro) . . . . .	340
__setConditionalBreak (C-SPY system macro) . . . . .	341
__setDataBreak (C-SPY system macro) . . . . .	343
__setDataLogBreak (C-SPY system macro) . . . . .	344
__setLogBreak (C-SPY system macro) . . . . .	345
__setRangeBreak (C-SPY system macro) . . . . .	346
__setSimBreak (C-SPY system macro) . . . . .	347
__setTraceStartBreak (C-SPY system macro) . . . . .	348
__setTraceStopBreak (C-SPY system macro) . . . . .	349
__smessage (C-SPY macro keyword) . . . . .	315
__sourcePosition (C-SPY system macro) . . . . .	350
__strFind (C-SPY system macro) . . . . .	350
__subString (C-SPY system macro) . . . . .	351
__targetDebuggerVersion (C-SPY system macro) . . . . .	351
__toLowerCase (C-SPY system macro) . . . . .	352
__toString (C-SPY system macro) . . . . .	352
__toUpperCase (C-SPY system macro) . . . . .	353
__unloadImage (C-SPY system macro) . . . . .	353
__var (C-SPY macro keyword) . . . . .	312
__writeFile (C-SPY system macro) . . . . .	354
__writeFileByte (C-SPY system macro) . . . . .	354
__writeMemoryByte (C-SPY system macro) . . . . .	355
__writeMemory8 (C-SPY system macro) . . . . .	355
__writeMemory16 (C-SPY system macro) . . . . .	355
__writeMemory32 (C-SPY system macro) . . . . .	356
-d (C-SPY command line option) . . . . .	371
-f (cspybat option) . . . . .	376
-p (C-SPY command line option) . . . . .	381
--allow_access_to_BSL (C-SPY command line option) . . . . .	368
--allow_locked_flash_access (C-SPY command line option) . . . . .	368
--attach_to_running_target (C-SPY command line option) . . . . .	368
--backend (C-SPY command line option) . . . . .	369
--code_coverage_file (C-SPY command line option) . . . . .	370
--connection (C-SPY command line option) . . . . .	369
--cycles (C-SPY command line option) . . . . .	370
--debugfile (cspybat option) . . . . .	371

--derivative (C-SPY command line option) . . . . .	372
--disable_interrupts (C-SPY command line option) . . . . .	372
--disable_memory_cache (C-SPY command line option) . . . . .	372
--download_only (C-SPY command line option) . . . . .	372
--eem (C-SPY command line option) . . . . .	373
--erase_exclude (C-SPY command line option) . . . . .	374
--erase_ip_protected (C-SPY command line option) . . . . .	374
--erase_main (C-SPY command line option) . . . . .	374
--erase_main_and_info (C-SPY command line option) . . . . .	375
--erase_retain_file (C-SPY command line option) . . . . .	375
--erase_retain_target (C-SPY command line option) . . . . .	375
--function_profiling (cspybat option) . . . . .	376
--hardware_multiplier (C-SPY command line option) . . . . .	377
--hwmult_type (C-SPY command line option) . . . . .	377
--jtag_speed (C-SPY command line option) . . . . .	378
--leave_target_running (C-SPY command line option) . . . . .	378
--lpt1 (C-SPY command line option) . . . . .	379
--lpt2 (C-SPY command line option) . . . . .	379
--lpt3 (C-SPY command line option) . . . . .	379
--macro (C-SPY command line option) . . . . .	379
--macro_param (C-SPY command line option) . . . . .	380
--mapu (C-SPY command line option) . . . . .	380
--odd_word_check (C-SPY command line option) . . . . .	380
--plugin (C-SPY command line option) . . . . .	381
--port (C-SPY command line option) . . . . .	382
--protocol (C-SPY command line option) . . . . .	382
--settlingtime (C-SPY command line option) . . . . .	383
--set_exit_breakpoint (C-SPY command line option) . . . . .	383
--set_getchar_breakpoint (C-SPY command line option) . . . . .	383
--set_putchar_breakpoint (C-SPY command line option) . . . . .	383
--silent (C-SPY command line option) . . . . .	384
--timeout (C-SPY command line option) . . . . .	384
--use_emulated_breakpoints (C-SPY command line option) . . . . .	384
--use_virtual_breakpoints (C-SPY command line option) . . . . .	385
--vccvoltage (C-SPY command line option) . . . . .	385
--verify_all (C-SPY command line option) . . . . .	385

# Numerics

1x Units (Symbolic Memory window context menu) . . . . .	154
8x Units (Memory window context menu) . . . . .	147