



**IAR Embedded  
Workbench**

# C-SPY® Debugging Guide

for Arm Limited's  
**Arm® cores**

## **COPYRIGHT NOTICE**

© 1999–2024 IAR Systems AB.

No part of this document may be reproduced without the prior written consent of IAR Systems AB. The software described in this document is furnished under a license and may only be used or copied in accordance with the terms of such a license.

## **DISCLAIMER**

The information in this document is subject to change without notice and does not represent a commitment on any part of IAR Systems. While the information contained herein is assumed to be accurate, IAR Systems assumes no responsibility for any errors or omissions.

In no event shall IAR Systems, its employees, its contractors, or the authors of this document be liable for special, direct, indirect, or consequential damage, losses, costs, charges, claims, demands, claim for lost profits, fees, or expenses of any nature or kind.

## **TRADEMARKS**

IAR Systems, IAR Embedded Workbench, Embedded Trust, C-Trust, IAR Connect, C-SPY, C-RUN, C-STAT, IAR Visual State, IAR KickStart Kit, I-jet, I-jet Trace, I-scope, IAR Academy, IAR, and the logotype of IAR Systems are trademarks or registered trademarks owned by IAR Systems AB.

Microsoft and Windows are registered trademarks of Microsoft Corporation.

Arm, Cortex, Thumb, and TrustZone are registered trademarks of Arm Limited. EmbeddedICE is a trademark of Arm Limited. uC/OS-II and uC/OS-III are trademarks of Micrium, Inc. CMX-RTX is a trademark of CMX Systems, Inc. Azure RTOS ThreadX is a trademark of Microsoft Corporation. RTX is a trademark of Quadros Systems. Fusion is a trademark of Unicoi Systems.

Renesas Synergy is a trademark of Renesas Electronics Corporation.

Adobe and Acrobat Reader are registered trademarks of Adobe Systems Incorporated.

All other product names are trademarks or registered trademarks of their respective owners.

## **EDITION NOTICE**

Twenty-seventh edition: June 2024

Part number: UCSARM-27

This guide applies to version 9.60.x of IAR Embedded Workbench® for Arm.

Internal reference: BB17, FF9.3.x, ISOC.

# Brief contents

Tables .....	27
Preface .....	29
<b>Part 1. Basic debugging</b> .....	<b>37</b>
The IAR C-SPY Debugger .....	39
Getting started using C-SPY .....	55
Executing your application .....	75
Variables and expressions .....	97
Breakpoints .....	125
Memory and registers .....	163
<b>Part 2. Analyzing your application</b> .....	<b>207</b>
Trace .....	209
The application timeline .....	257
Profiling .....	293
Code coverage .....	307
Performance monitoring .....	313
Power debugging .....	321
C-RUN runtime error checking .....	349
<b>Part 3. Advanced debugging</b> .....	<b>389</b>
Multicore debugging .....	391
Interrupts .....	401
C-SPY macros .....	427

The C-SPY command line utility—cspybat .....	515
Flash loaders .....	575
<b>Part 4. Additional reference information</b> .....	<b>581</b>
Debugger options .....	583
Additional information on C-SPY drivers .....	631
Index .....	661



# Contents

Tables .....	27
Preface .....	29
<b>Who should read this guide</b> .....	29
Required knowledge .....	29
<b>How to use this guide</b> .....	29
<b>What this guide contains</b> .....	30
Part 1. Basic debugging .....	30
Part 2. Analyzing your application .....	30
Part 3. Advanced debugging .....	31
Part 4. Additional reference information .....	31
<b>Other documentation</b> .....	31
User and reference guides .....	32
The online help system .....	32
Web sites .....	32
<b>Document conventions</b> .....	33
Typographic conventions .....	33
Naming conventions .....	34
<b>Part I. Basic debugging</b> .....	37
The IAR C-SPY Debugger .....	39
<b>Introduction to C-SPY</b> .....	39
An integrated environment .....	39
General C-SPY debugger features .....	40
RTOS awareness .....	41
<b>Debugger concepts</b> .....	42
C-SPY and target systems .....	43
The debugger .....	43
The target system .....	43
The application .....	43
C-SPY debugger systems .....	44

The ROM-monitor program .....	44
Third-party debuggers .....	44
C-SPY plugin modules .....	44
<b>Execution modes .....</b>	<b>45</b>
<b>C-SPY drivers overview .....</b>	<b>45</b>
Differences between the C-SPY drivers .....	46
<b>The IAR C-SPY Simulator .....</b>	<b>48</b>
Two simulator drivers .....	48
Supported features .....	48
<b>The C-SPY hardware debugger drivers .....</b>	<b>49</b>
Communication overview .....	49
Hardware installation .....	50
USB driver installation .....	51
<b>Getting started using C-SPY .....</b>	<b>55</b>
<b>Setting up C-SPY .....</b>	<b>55</b>
Setting up for debugging .....	55
Executing from reset .....	56
Using a setup macro file .....	57
Selecting a device description file .....	57
Loading plugin modules .....	57
<b>Starting C-SPY .....</b>	<b>58</b>
Starting a debug session .....	58
Loading executable files built outside of the IDE .....	58
Starting a debug session with source files missing .....	59
Loading multiple debug images .....	59
Editing in C-SPY windows .....	60
<b>Adapting for target hardware .....</b>	<b>61</b>
Modifying a device description file .....	61
Initializing target hardware before C-SPY starts .....	62
Remapping memory .....	63
Using predefined C-SPY macros for device support .....	63
Debug authentication .....	63

<b>An overview of the debugger startup</b> .....	64
Debugging code in flash .....	65
Debugging code in RAM .....	66
<b>Reference information on starting C-SPY</b> .....	66
C-SPY Debugger main window .....	67
Images window .....	72
Get Alternative File dialog box .....	73
<b>Executing your application</b> .....	75
<b>Introduction to application execution</b> .....	75
Briefly about application execution .....	75
Source and disassembly mode debugging .....	75
Single stepping .....	76
Troubleshooting slow stepping speed .....	78
Running the application .....	79
Highlighting .....	80
Viewing the call stack .....	81
Terminal input and output .....	81
Debug logging .....	82
<b>Reference information on application execution</b> .....	82
Disassembly window .....	83
Call Stack window .....	88
Terminal I/O window .....	90
Terminal I/O Log File dialog box .....	91
Debug Log window .....	92
Fault exception viewer window .....	93
Report Assert dialog box .....	94
Autostep settings dialog box .....	95
<b>Variables and expressions</b> .....	97
<b>Introduction to working with variables and expressions</b> .....	97
Briefly about working with variables and expressions .....	97
C-SPY expressions .....	98
Limitations on variable information .....	101

<b>Working with variables and expressions</b> .....	102
Using the windows related to variables and expressions .....	102
Viewing assembler variables .....	102
<b>Reference information on working with variables and expressions</b> .....	103
Auto window .....	104
Locals window .....	106
Watch window .....	109
Live Watch window .....	112
Statics window .....	115
Quick Watch window .....	118
Symbols window .....	121
Resolve Symbol Ambiguity dialog box .....	124
<b>Breakpoints</b> .....	125
<b>Introduction to setting and using breakpoints</b> .....	125
Reasons for using breakpoints .....	125
Briefly about setting breakpoints .....	126
Breakpoint types .....	126
Breakpoint icons .....	129
Breakpoints in the C-SPY simulator .....	129
Breakpoints in the C-SPY hardware debugger drivers .....	129
Breakpoint consumers .....	130
Breakpoint options .....	131
<b>Setting breakpoints</b> .....	131
Various ways to set a breakpoint .....	131
Toggling a simple code breakpoint .....	132
Setting breakpoints using the dialog box .....	132
Setting a data breakpoint in the Memory window .....	133
Setting breakpoints using system macros .....	134
Setting a breakpoint on an exception vector .....	135
Setting breakpoints in __ramfunc declared functions .....	136
Useful breakpoint hints .....	136

<b>Reference information on breakpoints</b> .....	138
Breakpoints window .....	138
Breakpoint Usage window .....	140
Code breakpoints dialog box .....	141
JTAG Watchpoints dialog box .....	143
Log breakpoints dialog box .....	146
Data breakpoints dialog box .....	147
Data Log breakpoints dialog box .....	151
Data Log breakpoints dialog box (C-SPY hardware drivers) .....	152
Breakpoints options .....	154
Immediate breakpoints dialog box .....	156
Vector Catch dialog box .....	157
Flash breakpoints dialog box .....	158
Enter Location dialog box .....	159
Resolve Source Ambiguity dialog box .....	161
<b>Memory and registers</b> .....	163
<b>Introduction to monitoring memory and registers</b> .....	163
Briefly about monitoring memory and registers .....	163
C-SPY memory zones .....	165
Memory configuration for the C-SPY simulator .....	165
Memory configuration for C-SPY hardware debugger drivers .....	166
<b>Monitoring memory and registers</b> .....	167
Defining application-specific register groups .....	167
Monitoring stack usage .....	168
<b>Reference information on memory and registers</b> .....	171
Memory window .....	172
Memory Save dialog box .....	176
Memory Restore dialog box .....	177
Fill dialog box .....	178
Symbolic Memory window .....	179
Stack window .....	182
Registers window .....	186
Register User Groups Setup window .....	189

SFR Setup window .....	191
Edit SFR dialog box .....	194
Memory Configuration dialog box for the C-SPY simulator .....	196
Edit Memory Range dialog box for the C-SPY simulator .....	198
Memory Configuration dialog box for C-SPY hardware debugger drivers .....	200
Edit Memory Range dialog box for C-SPY hardware debugger drivers .....	203

## **Part 2. Analyzing your application** ..... 207

### **Trace** ..... 209

#### **Introduction to using trace** ..... 209

Reasons for using trace ..... 209

Briefly about trace ..... 210

Requirements for using trace ..... 212

#### **Collecting and using trace data** ..... 213

Getting started with ETM trace ..... 214

Getting started with SWO trace ..... 214

Getting started with MTB trace ..... 215

Setting up concurrent use of ETM and SWO ..... 216

Trace data collection using breakpoints ..... 216

Searching in trace data ..... 217

Browsing through trace data ..... 217

#### **Reference information on trace** ..... 218

ETM Trace Settings dialog box (I-jet) ..... 219

ETM Trace Settings dialog box (J-Link/J-Trace) ..... 221

SWO Trace Window Settings dialog box ..... 223

SWO Configuration dialog box ..... 225

Trace window ..... 229

Function Trace window ..... 238

Trace Start Trigger breakpoint dialog box ..... 239

Trace Stop Trigger breakpoint dialog box ..... 240

Trace Start breakpoints dialog box (I-jet and CMSIS-DAP) ..... 241

Trace Stop breakpoints dialog box (I-jet and CMSIS-DAP) .....	243
Trace Filter breakpoints dialog box (I-jet) .....	245
Trace Start breakpoints dialog box (J-Link/J-Trace) .....	246
Trace Stop breakpoints dialog box (J-Link/J-Trace) .....	249
Trace Filter breakpoints dialog box (J-Link/J-Trace) .....	251
Find in Trace dialog box .....	253
Find in Trace window .....	255
Trace Save dialog box .....	256
<b>The application timeline .....</b>	<b>257</b>
<b>Introduction to analyzing your application's timeline .....</b>	<b>257</b>
Briefly about analyzing the timeline .....	257
Requirements for timeline support .....	259
<b>Analyzing your application's timeline .....</b>	<b>259</b>
Displaying a graph in the Timeline window .....	260
Navigating in the graphs .....	261
Analyzing performance using the graph data .....	261
Getting started using data logging .....	262
Getting started using event logging .....	264
<b>Reference information on application timeline .....</b>	<b>265</b>
Data Log window .....	266
Data Log Summary window .....	269
Event Log window .....	271
Event Log Summary window .....	274
Timeline window—Call Stack graph .....	277
Timeline window—Data Log graph .....	282
Timeline window—Events graph .....	286
Viewing Range dialog box .....	290
<b>Profiling .....</b>	<b>293</b>
<b>Introduction to the profiler .....</b>	<b>293</b>
Reasons for using the profiler .....	293
Briefly about the profiler .....	293
Requirements for using the profiler .....	294

<b>Using the profiler</b> .....	295
Getting started using the profiler on function level .....	296
Analyzing the profiling data .....	296
Getting started using the profiler on instruction level .....	298
Selecting a time interval for profiling information .....	299
<b>Reference information on the profiler</b> .....	300
Function Profiler window .....	301
Code coverage .....	307
<b>Introduction to code coverage</b> .....	307
Reasons for using code coverage .....	307
Briefly about code coverage .....	307
Requirements and restrictions for using code coverage .....	307
<b>Reference information on code coverage</b> .....	308
Code Coverage window .....	308
Performance monitoring .....	313
<b>Introduction to performance monitoring</b> .....	313
Briefly about performance monitoring .....	313
Requirements and restrictions for using performance monitoring ...	313
Event types .....	314
Detecting counter overflow .....	315
<b>Setting up performance monitoring</b> .....	315
<b>Reference information on performance monitoring</b> .....	316
Performance Monitoring window .....	316
Power debugging .....	321
<b>Introduction to power debugging</b> .....	321
Reasons for using power debugging .....	321
Briefly about power debugging .....	321
Requirements and restrictions for power debugging .....	323
<b>Optimizing your source code for power consumption</b> .....	323
Waiting for device status .....	324
Software delays .....	324
DMA versus polled I/O .....	324



Low-power mode diagnostics .....	324
CPU frequency .....	325
Detecting mistakenly unattended peripherals .....	325
Peripheral units in an event-driven system .....	326
Finding conflicting hardware setups .....	327
Analog interference .....	327
<b>Debugging in the power domain .....</b>	<b>328</b>
Displaying a power profile and analyzing the result .....	328
Detecting unexpected power usage during application execution ...	329
Changing the graph resolution .....	330
<b>Reference information on power debugging .....</b>	<b>330</b>
Power Log Setup window .....	331
Power Log window .....	334
Timeline window—Power graph .....	338
State Log window .....	339
State Log Summary window .....	341
Timeline window—State Log graph .....	344
<b>C-RUN runtime error checking .....</b>	<b>349</b>
<b>Introduction to runtime error checking .....</b>	<b>349</b>
Runtime error checking .....	349
Runtime error checking using C-RUN .....	350
The checked heap provided by the library .....	351
Using C-RUN in the IAR Embedded Workbench IDE .....	351
Using C-RUN in non-interactive mode .....	352
Requirements for runtime error checking .....	352
<b>Using C-RUN .....</b>	<b>353</b>
Getting started using C-RUN runtime error checking .....	353
Creating rules for messages .....	355
<b>Detecting various runtime errors .....</b>	<b>355</b>
Detecting implicit or explicit integer conversion .....	355
Detecting signed or unsigned overflow .....	357
Detecting bit loss or undefined behavior when shifting .....	359
Detecting division by zero .....	360

Detecting unhandled cases in switch statements .....	360
Detecting accesses outside the bounds of arrays and other objects ..	361
Detecting heap usage error .....	367
Detecting heap memory leaks .....	368
Detecting heap integrity violations .....	370
<b>Reference information on runtime error checking .....</b>	<b>373</b>
C-RUN Runtime Checking options .....	373
C-RUN Messages window .....	376
C-RUN Messages Rules window .....	378
<b>Compiler and linker reference for C-RUN .....</b>	<b>379</b>
--bounds_table_size .....	380
--debug_heap .....	381
--generate_entries_without_bounds .....	381
--ignore_uninstrumented_pointers .....	381
--ignore_uninstrumented_pointers .....	382
--runtime_checking .....	382
#pragma default_no_bounds .....	383
#pragma define_with_bounds .....	383
#pragma define_without_bounds .....	383
#pragma disable_check .....	384
#pragma generate_entry_without_bounds .....	384
#pragma no_arith_checks .....	385
#pragma no_bounds .....	385
__as_get_base .....	385
__as_get_bound .....	385
__as_make_bounds .....	386
<b>cspybat options for C-RUN .....</b>	<b>386</b>
--rtc_enable .....	387
--rtc_output .....	387
--rtc_raw_to_txt .....	387
--rtc_rules .....	388

<b>Part 3. Advanced debugging</b> .....	389
Multicore debugging .....	391
<b>Introduction to multicore debugging</b> .....	391
Briefly about multicore debugging .....	391
Symmetric multicore debugging .....	391
Asymmetric multicore debugging .....	392
Requirements and restrictions for multicore debugging .....	393
<b>Debugging multiple cores</b> .....	393
Setting up for symmetric multicore debugging .....	393
Setting up for asymmetric multicore debugging .....	393
Starting and stopping a multicore debug session .....	396
<b>Reference information on multicore debugging</b> .....	396
Cores window .....	397
Multicore toolbar .....	399
The multicore session file .....	399
Interrupts .....	401
<b>Introduction to interrupts</b> .....	401
Briefly about the interrupt simulation system .....	401
Interrupt characteristics .....	402
Interrupt simulation states .....	403
C-SPY system macros for interrupt simulation .....	404
Target-adapting the interrupt simulation system .....	405
Briefly about interrupt logging .....	405
<b>Using the interrupt system</b> .....	406
Simulating a simple interrupt .....	406
Simulating an interrupt in a multi-task system .....	408
Getting started using interrupt logging .....	409
<b>Reference information on interrupts</b> .....	409
Interrupt Configuration window .....	410
Available Interrupts window .....	413
Interrupt Status window .....	414
Interrupt Log window .....	416

Interrupt Log Summary window .....	420
Timeline window—Interrupt Log graph .....	422
<b>C-SPY macros</b> .....	427
<b>Introduction to C-SPY macros</b> .....	427
Reasons for using C-SPY macros .....	427
Briefly about using C-SPY macros .....	428
Briefly about setup macro functions and files .....	428
Briefly about the macro language .....	429
<b>Using C-SPY macros</b> .....	429
Registering C-SPY macros—an overview .....	430
Executing C-SPY macros—an overview .....	430
Registering and executing using setup macros and setup files .....	431
Executing macros using Quick Watch .....	432
Executing a macro by connecting it to a breakpoint .....	432
Aborting a C-SPY macro .....	434
<b>Reference information on the macro language</b> .....	434
Macro functions .....	434
Macro variables .....	435
Macro parameters .....	435
Macro strings .....	436
Macro statements .....	436
Formatted output .....	438
<b>Reference information on reserved setup macro function names</b> .....	439
execConfigureTraceETM .....	440
execConfigureTraceSWO .....	440
execUserAttach .....	441
execUserPreload .....	441
execUserExecutionStarted .....	441
execUserExecutionStopped .....	441
execUserFlashInit .....	442
execUserSetup .....	442
execUserFlashReset .....	442

execUserPreReset .....	443
execUserReset .....	443
execUserExit .....	443
execUserFlashExit .....	443
execUserCoreConnect .....	444
<b>Reference information on C-SPY system macros .....</b>	<b>444</b>
__abortLaunch .....	448
__cancelAllInterrupts .....	449
__cancelInterrupt .....	449
__clearBreak .....	450
__closeFile .....	450
__delay .....	450
__disableInterrupts .....	451
__driverType .....	451
__emulatorSpeed .....	452
__emulatorStatusCheckOnRead .....	453
__enableInterrupts .....	453
__evaluate .....	454
__expandVar .....	454
__fillMemory8 .....	455
__fillMemory16 .....	456
__fillMemory32 .....	457
__fillMemory64 .....	458
__gdbserver_exec_command .....	459
__getNumberOfCores .....	459
__getSelectedCore .....	459
__getTracePortSize .....	460
__hasDAPRegs .....	461
__hwJetResetWithStrategy .....	461
__hwReset .....	462
__hwResetRunToBp .....	462
__hwResetWithStrategy .....	464
__hwRunToBreakpoint .....	464
__isBatchMode .....	465

__isMacroSymbolDefined .....	466
__jlinkExecCommand .....	466
__jlinkExecMacro .....	467
__jtagCommand .....	467
__jtagCP15IsPresent .....	468
__jtagCP15ReadReg .....	468
__jtagCP15WriteReg .....	468
__jtagData .....	469
__jtagRawRead .....	469
__jtagRawSync .....	470
__jtagRawWrite .....	471
__jtagResetTRST .....	472
__loadImage .....	472
__memoryRestore .....	473
__memorySave .....	474
__messageBoxYesCancel .....	475
__messageBoxYesNo .....	476
__openFile .....	476
__orderInterrupt .....	477
__popSimulatorInterruptExecutingStack .....	478
__probeType .....	479
__readAPReg .....	480
__readDPRReg .....	480
__readFile .....	481
__readFileByte .....	481
__readMemory8, __readMemoryByte .....	482
__readMemory16 .....	482
__readMemory32 .....	483
__readMemory64 .....	483
__registerMacroFile .....	484
__resetFile .....	484
__restoreSoftwareBreakpoints .....	484
__selectCore .....	485
__setCodeBreak .....	486

__setDataBreak .....	487
__setDataLogBreak .....	489
__setLogBreak .....	490
__setSimBreak .....	492
__setTraceStartBreak .....	493
__setTraceStopBreak .....	495
__sourcePosition .....	496
__strFind .....	497
__subString .....	497
__system1 .....	498
__system2 .....	499
__system3 .....	500
__targetDebuggerVersion .....	500
__toLower .....	501
__toString .....	501
__toUpper .....	502
__unloadImage .....	502
__wallTime_ms .....	503
__whichCore .....	503
__writeAPReg .....	504
__writeDPReg .....	505
__writeFile .....	505
__writeFileByte .....	506
__writeMemory8, __writeMemoryByte .....	506
__writeMemory16 .....	506
__writeMemory32 .....	507
__writeMemory64 .....	508
<b>Graphical environment for macros .....</b>	<b>508</b>
Macro Registration window .....	509
Debugger Macros window .....	511
Macro Quicklaunch window .....	513

The C-SPY command line utility— <code>cspybat</code> .....	515
<b>Using C-SPY in batch mode</b> .....	515
Starting <code>cspybat</code> .....	515
Output .....	516
Invocation syntax .....	516
<b>Summary of C-SPY command line options</b> .....	517
General <code>cspybat</code> options .....	517
Options available for all C-SPY drivers .....	519
Options available for the simulator driver .....	520
Options available for the C-SPY GDB Server driver .....	520
Options available for the C-SPY I-jet driver .....	521
Options available for the C-SPY CMSIS-DAP driver .....	522
Options available for the C-SPY J-Link/J-Trace driver .....	524
Options available for the C-SPY TI MSP-FET driver .....	525
Options available for the C-SPY TI Stellaris driver .....	525
Options available for the C-SPY TI XDS driver .....	525
Options available for the C-SPY ST-LINK driver .....	526
Options available for the C-SPY third-party drivers .....	527
<b>Reference information on C-SPY command line options</b> ...	527
--application_args .....	527
--attach_to_running_target .....	528
--backend .....	528
--code_coverage_file .....	529
--cycles .....	529
--debug_auth_enforce .....	530
--debug_auth_settings .....	530
--debug_auth_type .....	531
--debug_file .....	531
--device .....	532
--device_macro .....	532
--disable_interrupts .....	532
--download_only .....	533
--drv_catch_exceptions .....	533



--drv_communication .....	534
--drv_communication_log .....	538
--drv_debugger_cache .....	538
--drv_default_breakpoint .....	539
--drv_enforce_mem_config .....	540
--drv_exclude_from_verify .....	540
--drv_interface .....	541
--drv_interface_speed .....	542
--drv_mem_ap .....	543
--drv_reset_to_cpu_start .....	543
--drv_restore_breakpoints .....	544
--drv_swo_clock_setup .....	544
--drv_trace_settings .....	545
--drv_vector_table_base .....	546
-f .....	547
--flash_loader .....	547
--function_profiling .....	548
--gdbserv_exec_command .....	548
--jet_board_cfg .....	548
--jet_board_did .....	549
--jet_cpu_clock .....	550
--jet_disable_pmu .....	550
--jet_disable_pmu_dap .....	551
--jet_ir_length .....	551
--jet_power_from_probe .....	551
--jet_probe .....	552
--jet_script_file .....	552
--jet_standard_reset .....	553
--jet_startup_connection_timeout .....	554
--jet_swo_on_d0 .....	555
--jet_swo_prescaler .....	555
--jet_swo_protocol .....	555
--jet_tap_position .....	556
--jlink_dcc_timeout .....	556

--jlink_device_select .....	557
--jlink_exec_command .....	557
--jlink_initial_speed .....	558
--jlink_ir_length .....	558
--jlink_reset_strategy .....	559
--jlink_script_file .....	559
--jlink_trace_source .....	560
--leave_target_running .....	560
--lmiftdi_reset_strategy .....	561
--macro .....	561
--macro_param .....	562
--mapu .....	562
--mspfet_erase_flash .....	562
--mspfet_interface_speed .....	563
--mspfet_reset_strategy .....	563
--mspfet_settlingtime .....	564
--mspfet_vccvoltage .....	564
--multicore_nr_of_cores .....	564
-p .....	565
--plugin .....	565
--proc_stack_stack .....	566
--reset_style .....	566
--sdm_debug_architecture .....	568
--sdm_library .....	568
--sdm_library_hint .....	569
--sdm_manifest .....	569
--semihosting .....	570
--silent .....	570
--sockets .....	571
--stlink_reset_strategy .....	571
--suppress_entrpoint_warning .....	572
--timeout .....	572
--xds_board_file .....	572
--xds_reset_strategy .....	573

--xds_rootdir .....	574
<b>Flash loaders .....</b>	<b>575</b>
<b>Introduction to the flash loader .....</b>	<b>575</b>
<b>Using flash loaders .....</b>	<b>575</b>
Setting up the flash loader(s) .....	575
The flash loading mechanism .....	576
Aborting a flash loader .....	576
<b>Reference information on the flash loader .....</b>	<b>577</b>
Flash Loader Overview dialog box .....	577
Flash Loader Configuration dialog box .....	579
<b>Part 4. Additional reference information .....</b>	<b>581</b>
<b>Debugger options .....</b>	<b>583</b>
<b>Setting debugger options .....</b>	<b>583</b>
<b>Reference information on general debugger options .....</b>	<b>584</b>
Setup .....	585
Download .....	586
Images .....	587
Multicore .....	588
Authentication .....	590
Extra Options .....	591
Plugins .....	592
<b>Reference information on C-SPY hardware debugger driver options .....</b>	<b>593</b>
CADI — Setup .....	594
CMSIS-DAP — Setup .....	595
CMSIS-DAP — Interface .....	598
E2 — Setup .....	600
GDB Server .....	601
G+LINK — Setup .....	601
I-jet — Setup .....	602
I-jet — Interface .....	605

I-jet — Trace .....	607
J-Link/J-Trace — Setup .....	611
J-Link/J-Trace — Connection .....	615
Nu-Link — Setup .....	617
PE micro — Setup .....	617
ST-LINK — Setup .....	618
ST-LINK — Communication .....	621
ST-LINK — Multicore .....	622
TI MSP-FET — Setup .....	623
TI MSP-FET — Download .....	624
TI Stellaris — Setup .....	625
TI XDS — Setup .....	627
TI XDS — Communication .....	629
Third-Party Driver options .....	630
<b>Additional information on C-SPY drivers .....</b>	<b>631</b>
<b>Reference information on C-SPY driver menus .....</b>	<b>631</b>
<i>C-SPY driver</i> .....	631
Simulator menu (IAR native) .....	632
Simulator menu (Imperas) .....	634
<b>Reference information on the C-SPY simulator .....</b>	<b>635</b>
Simulated Frequency dialog box .....	635
<b>Reference information on the C-SPY hardware debugger     drivers .....</b>	<b>635</b>
CADI menu .....	636
CMSIS-DAP menu .....	637
E2 menu .....	639
GDB Server menu .....	640
G+LINK menu .....	641
I-jet menu .....	642
J-Link menu .....	646
Nu-Link menu .....	650
ST-Link menu .....	650
TI MSP-FET menu .....	653

TI Stellaris menu .....	655
TI XDS menu .....	656
<b>Resolving problems</b> .....	659
No contact with the target hardware .....	659
<b>Index</b> .....	661



# Tables

1: Typographic conventions used in this guide .....	33
2: Naming conventions used in this guide .....	34
3: Driver differences—Simulator, I-jet, J-Link/J-Trace, ST-LINK, TI XDS, etc .....	46
4: Driver differences—other drivers .....	47
5: Terminal I/O in real time .....	90
6: C-SPY assembler symbols expressions .....	100
7: Handling name conflicts between hardware registers and assembler labels .....	100
8: Live watch for the different devices .....	112
9: C-SPY macros for breakpoints .....	134
10: C-SPY macros for breakpoints .....	134
11: Support for timeline information .....	259
12: C-SPY driver profiling support .....	295
13: Project options for enabling the profiler .....	296
14: Timer interrupt settings .....	408
15: Examples of C-SPY macro variables .....	435
16: Summary of system macros .....	444
17: __cancelInterrupt return values .....	449
18: __disableInterrupts return values .....	451
19: __driverType return values .....	452
20: __emulatorSpeed return values .....	452
21: __enableInterrupts return values .....	453
22: __evaluate return values .....	454
23: __expandVar return values .....	454
24: __getTracePortSize return values .....	460
25: __hasDAPRegs return values .....	461
26: __hwJetResetWithStrategy return values .....	461
27: __hwReset return values .....	462
28: __hwResetRunToBp return values .....	463
29: __hwResetWithStrategy return values .....	464
30: __hwRunToBreakpoint return values .....	465
31: __isBatchMode return values .....	465

32: __jtagResetTRST return values .....	472
33: __loadImage return values .....	473
34: __messageBoxYesCancel return values .....	475
35: __messageBoxYesNo return values .....	476
36: __openFile return values .....	477
37: __probeType return values .....	479
38: __readAPReg return values .....	480
39: __readDPReg return values .....	480
40: __readFile return values .....	481
41: __setCodeBreak return values .....	486
42: __setDataBreak return values .....	488
43: __setDataLogBreak return values .....	490
44: __setLogBreak return values .....	491
45: __setSimBreak return values .....	492
46: __setTraceStartBreak return values .....	494
47: __setTraceStopBreak return values .....	496
48: __sourcePosition return values .....	496
49: __unloadImage return values .....	503
50: __writeAPReg return values .....	504
51: __writeDPReg return values .....	505
52: cspybat parameters .....	516
53: Options specific to the C-SPY drivers you are using .....	583



# Preface

Welcome to the *C-SPY® Debugging Guide for Arm*. The purpose of this guide is to help you fully use the features in the IAR C-SPY® Debugger for debugging your application based on the Arm core.

---

## Who should read this guide

Read this guide if you plan to develop an application using IAR Embedded Workbench and want to get the most out of the features available in C-SPY.

### REQUIRED KNOWLEDGE

To use the tools in IAR Embedded Workbench, you should have working knowledge of:

- The architecture and instruction set of the Arm core you are using (refer to the chip manufacturer's documentation)
- The C or C++ programming language
- Application development for embedded systems
- The operating system of your host computer.

For more information about the other development tools incorporated in the IDE, refer to their respective documentation, see *Other documentation*, page 31.

---

## How to use this guide

If you are new to using IAR Embedded Workbench, we suggest that you first go through the tutorials, which you can find in the Information Center, for an overview of the tools and the features that the IDE offers.

The process of managing projects and building, as well as editing, is described in the *IDE Project Management and Building Guide for Arm*, whereas information about how to use C-SPY for debugging is described in this guide.

This guide describes a number of *topics*, where each topic section contains an introduction which also covers concepts related to the topic. This will give you a good understanding of the features in C-SPY. Furthermore, the topic section provides procedures with step-by-step descriptions to help you use the features. Finally, each topic section contains all relevant reference information.

We also recommend the Glossary, which you can find in the *IDE Project Management and Building Guide for Arm*, if you should encounter any unfamiliar terms in the IAR user and reference guides.

---

## What this guide contains

Below is a brief outline and summary of the chapters in this guide.

**Note:** Some of the screenshots in this guide are taken from a similar product and not from IAR Embedded Workbench for Arm.

### PART I. BASIC DEBUGGING

- *The IAR C-SPY Debugger* introduces you to the C-SPY debugger and to the concepts that are related to debugging in general and to C-SPY in particular. The chapter also introduces the various C-SPY drivers. The chapter briefly shows the difference in functionality that the various C-SPY drivers provide.
- *Getting started using C-SPY* helps you get started using C-SPY, which includes setting up, starting, and adapting C-SPY for target hardware.
- *Executing your application* describes the conceptual differences between source and disassembly mode debugging, the facilities for executing your application, and finally, how you can handle terminal input and output.
- *Variables and expressions* describes the syntax of the expressions and variables used in C-SPY, as well as the limitations on variable information. The chapter also demonstrates the various methods for monitoring variables and expressions.
- *Breakpoints* describes the breakpoint system and the various ways to set breakpoints.
- *Memory and registers* shows how you can examine memory and registers.

### PART 2. ANALYZING YOUR APPLICATION

- *Trace* describes how you can inspect the program flow up to a specific state using trace data.
- *The application timeline* describes the **Timeline** window, and how to use the information in it to analyze your application's behavior.
- *Profiling* describes how the profiler can help you find the functions in your application source code where the most time is spent during execution.
- *Code coverage* describes how the code coverage functionality can help you verify whether all parts of your code have been executed, thus identifying parts which have not been executed.

- *Performance monitoring* describes the **Performance Monitoring** window, and how to use this window to view event counters or CPU clock cycles through the Performance Monitoring Unit (PMU).
- *Power debugging* describes techniques for power debugging and how you can use C-SPY to find source code constructions that result in unexpected power consumption.
- *C-RUN runtime error checking* describes how to use C-RUN for runtime error checking.

### **PART 3. ADVANCED DEBUGGING**

- *Multicore debugging* describes how to debug a target with multiple cores.
- *Interrupts* contains detailed information about the C-SPY interrupt simulation system and how to configure the simulated interrupts to make them reflect the interrupts of your target hardware.
- *C-SPY macros* describes the C-SPY macro system, its features, the purposes of these features, and how to use them.
- *The C-SPY command line utility—cspybat* describes how to use C-SPY in batch mode.
- *Flash loaders* describes the flash loader, what it is and how to use it.

### **PART 4. ADDITIONAL REFERENCE INFORMATION**

- *Debugger options* describes the options you must set before you start the C-SPY debugger.
- *Additional information on C-SPY drivers* describes menus and features provided by the C-SPY drivers not described in any dedicated topics.

---

## **Other documentation**

User documentation is available as hypertext PDFs and as a context-sensitive online help system in HTML format. You can access the documentation from the IAR Information Center or from the **Help** menu in the IAR Embedded Workbench IDE. The online help system is also available via the F1 key.

## USER AND REFERENCE GUIDES

The complete set of IAR development tools is described in a series of guides. Information about:

- System requirements and information about how to install and register the IAR products are available in the *Installation and Licensing Quick Reference Guide* and the *Licensing Guide*.
- Using the IDE for project management and building, is available in the *IDE Project Management and Building Guide for Arm*.
- Using the IAR C-SPY® Debugger and C-RUN runtime error checking, is available in the *C-SPY® Debugging Guide for Arm*.
- Programming for the IAR C/C++ Compiler for Arm and linking, is available in the *IAR C/C++ Development Guide for Arm*.
- Programming for the IAR Assembler for Arm, is available in the *IAR Assembler User Guide for Arm*.
- Performing a static analysis using C-STAT and the required checks, is available in the *C-STAT® Static Analysis Guide*.
- Using I-jet, refer to the *IAR Debug Probes User Guide for I-jet®, I-jet Trace, and I-scope*.
- Using IAR J-Link and IAR J-Trace, refer to the *J-Link/J-Trace User Guide*.
- Porting application code and projects created with a previous version of the IAR Embedded Workbench for Arm, is available in the *IAR Embedded Workbench® Migration Guide*.

**Note:** Additional documentation might be available depending on your product installation.

## THE ONLINE HELP SYSTEM

The context-sensitive online help contains information about:

- IDE project management and building
- Debugging using the IAR C-SPY® Debugger
- The IAR C/C++ Compiler and Linker
- The IAR Assembler
- C-STAT

## WEB SITES

Recommended web sites:

- The chip manufacturer's web site.

- The Arm Limited web site, [www.arm.com](http://www.arm.com), that contains information and news about the Arm cores.
- The IAR web site, [www.iar.com](http://www.iar.com), that holds application notes and other product information.
- The web site of the C standardization working group, [www.open-std.org/jtc1/sc22/wg14](http://www.open-std.org/jtc1/sc22/wg14).
- The web site of the C++ Standards Committee, [www.open-std.org/jtc1/sc22/wg21](http://www.open-std.org/jtc1/sc22/wg21).
- The C++ programming language web site, [isocpp.org](http://isocpp.org). This web site also has a list of recommended books about C++ programming.
- The C and C++ reference web site, [en.cppreference.com](http://en.cppreference.com).

---

## Document conventions

When, in the IAR documentation, we refer to the programming language C, the text also applies to C++, unless otherwise stated.

When referring to a directory in your product installation, for example `arm\doc`, the full path to the location is assumed, for example `c:\Program Files\IAR Systems\Embedded Workbench N.n\arm\doc`, where the initial digit of the version number reflects the initial digit of the version number of the IAR Embedded Workbench shared components.

## TYPOGRAPHIC CONVENTIONS

The IAR documentation set uses the following typographic conventions:

Style	Used for
<code>computer</code>	<ul style="list-style-type: none"> <li>• Source code examples and file paths.</li> <li>• Text on the command line.</li> <li>• Binary, hexadecimal, and octal numbers.</li> </ul>
<i>parameter</i>	A placeholder for an actual value used as a parameter, for example <i>filename.h</i> where <i>filename</i> represents the name of the file.
[option]	An optional part of a linker or stack usage control directive, where [ and ] are not part of the actual directive, but any [, ], {, or } are part of the directive syntax.
{option}	A mandatory part of a linker or stack usage control directive, where { and } are not part of the actual directive, but any [, ], {, or } are part of the directive syntax.
[option]	An optional part of a command line option, pragma directive, or library filename.

Table 1: Typographic conventions used in this guide





Style	Used for
[a   b   c]	An optional part of a command line option, pragma directive, or library filename with alternatives.
{a   b   c}	A mandatory part of a command line option, pragma directive, or library filename with alternatives.
<b>bold</b>	Names of menus, menu commands, buttons, and dialog boxes that appear on the screen.
<i>italic</i>	<ul style="list-style-type: none"> <li>• A cross-reference within this guide or to another guide.</li> <li>• Emphasis.</li> </ul>
...	An ellipsis indicates that the previous item can be repeated an arbitrary number of times.
	Identifies instructions specific to the IAR Embedded Workbench® IDE interface.
	Identifies instructions specific to the command line interface.
	Identifies helpful tips and programming hints.
	Identifies warnings.

Table 1: Typographic conventions used in this guide (Continued)

## NAMING CONVENTIONS

The following naming conventions are used for the products and tools from IAR, when referred to in the documentation:

Brand name	Generic term
IAR Embedded Workbench® for Arm	IAR Embedded Workbench®
IAR Embedded Workbench® IDE for Arm	the IDE
IAR C-SPY® Debugger for Arm	C-SPY, the debugger
IAR C-SPY® Simulator	the simulator
IAR C/C++ Compiler™ for Arm	the compiler
IAR Assembler™ for Arm	the assembler
IAR ILINK Linker™	ILINK, the linker
IAR DLIB Runtime Environment™	the DLIB runtime environment

Table 2: Naming conventions used in this guide

**In 32-bit mode** refers to using IAR Embedded Workbench for Arm configured for the instruction sets T32/T and A32.

**In 64-bit mode** refers to using IAR Embedded Workbench for Arm configured for the instruction set A64.

For more information, see *Execution modes*, page 45.





# Part I. Basic debugging

This part of the *C-SPY® Debugging Guide for Arm* includes chapters:

- The IAR C-SPY Debugger
- Getting started using C-SPY
- Executing your application
- Variables and expressions
- Breakpoints
- Memory and registers

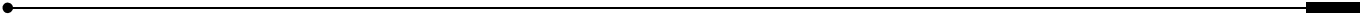
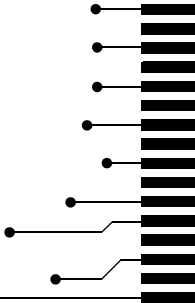



# The IAR C-SPY Debugger

- Introduction to C-SPY
- Debugger concepts
- Execution modes
- C-SPY drivers overview
- The IAR C-SPY Simulator
- The C-SPY hardware debugger drivers

---

## Introduction to C-SPY

These topics are covered:

- An integrated environment
- General C-SPY debugger features
- RTOS awareness

### AN INTEGRATED ENVIRONMENT

C-SPY is a high-level-language debugger for embedded applications. It is designed for use with the IAR compilers and assemblers, and is completely integrated in the IDE, providing development and debugging within the same application. This gives you possibilities such as:

- *Editing while debugging*  
During a debug session, you can make corrections directly in the same source code window that is used for controlling the debugging. Changes will be included in the next project rebuild.
- *Setting breakpoints at any point during the development cycle*  
You can inspect and modify breakpoint definitions also when the debugger is not running, and breakpoint definitions flow with the text as you edit. Your debug settings, such as watch properties, window layouts, and register groups will be preserved between your debug sessions.

**Note:** Setting breakpoints when the debugger is running is not supported by the C-SPY Simulator for all cores or devices.

All windows that are open in the IAR Embedded Workbench workspace will stay open when you start the C-SPY Debugger. In addition, a set of C-SPY-specific windows are opened.

## GENERAL C-SPY DEBUGGER FEATURES

Because IAR provides an entire toolchain, the output from the compiler and linker can include extensive debug information for the debugger, resulting in good debugging possibilities for you.

C-SPY offers these general features:

- *Source and disassembly level debugging*  
C-SPY allows you to switch between source and disassembly debugging as required, for both C or C++ and assembler source code.
- *Single-stepping on a function call level*  
Compared to traditional debuggers, where the finest granularity for source level stepping is line by line, C-SPY provides a finer level of control by identifying every statement and function call as a step point. This means that each function call—inside expressions, and function calls that are part of parameter lists to other functions—can be single-stepped. The latter is especially useful when debugging C++ code, where numerous extra function calls are made, for example to object constructors.
- *Code and data breakpoints*  
The C-SPY breakpoint system lets you set breakpoints of various kinds in the application being debugged, allowing you to stop at locations of particular interest. For example, you set breakpoints to investigate whether your program logic is correct or to investigate how and when the data changes.
- *Monitoring variables and expressions*  
For variables and expressions there is a wide choice of facilities. You can easily monitor values of a specified set of variables and expressions, continuously or on demand. You can also choose to monitor only local variables, static variables, etc.
- *Container awareness*  
When you run your application in C-SPY, you can view the elements of library data types such as STL lists and vectors. This gives you a very good overview and debugging opportunities when you work with C++ STL containers.
- *Call stack information*  
The compiler generates extensive call stack information. This allows the debugger to show, without any runtime penalty, the complete stack of function calls wherever the program counter is. You can select any function in the call stack, and for each function you get valid information for local variables and available registers.

- *Powerful macro system*

C-SPY includes a powerful internal macro system, to allow you to define complex sets of actions to be performed. C-SPY macros can be used on their own or in conjunction with complex breakpoints and—for some cores or devices—the interrupt simulation system to perform a wide variety of tasks.

### **Additional general C-SPY debugger features**

This list shows some additional features:

- Threaded execution keeps the IDE responsive while running the target application
- Automatic stepping
- The source browser provides easy navigation to functions, types, and variables
- Extensive type recognition of variables
- Configurable registers (CPU and peripherals) and memory windows
- Graphical stack view with overflow detection
- Support for code coverage and function level profiling (not supported by the C-SPY Simulator for all cores or devices)
- Support for performance monitoring of event counters and CPU clock cycles through the Performance Monitoring Unit (PMU)
- The target application can access files on the host PC using file I/O
- Optional terminal I/O emulation

### **RTOS AWARENESS**

C-SPY supports RTOS-aware debugging.

These operating systems are currently supported:

- AVIX-RT
- Azure RTOS ThreadX
- CMX-RTX
- CMX-Tiny+
- eForce mC3/Compact
- eSysTech X realtime kernel
- FreeRTOS, OpenRTOS, and SafeRTOS
- Freescale MQX
- Micrium uC/OS-II
- Micrium uC/OS-III
- Micro Digital SMX

- MISPO NORTi
- OSEK Run Time Interface (ORTI)
- RTXQ Quadros
- Segger embOS
- unicon Fusion

RTOS plugin modules can be provided by IAR, and by third-party suppliers. Contact your software distributor or IAR representative, alternatively visit the IAR web site, for information about supported RTOS modules.

A C-SPY RTOS awareness plugin module gives you a high level of control and visibility over an application built on top of an RTOS. It displays RTOS-specific items like task lists, queues, semaphores, mailboxes, and various RTOS system variables. Task-specific breakpoints and task-specific stepping make it easier to debug tasks.

A loaded plugin will add its own menu, set of windows, and buttons when a debug session is started (provided that the RTOS is linked with the application). For information about other RTOS awareness plugin modules, refer to the manufacturer of the plugin module. For links to the RTOS documentation, see the release notes that are available from the **Help** menu.

---

## Debugger concepts

This section introduces some of the concepts and terms that are related to debugging in general and to C-SPY in particular. This section does not contain specific information related to C-SPY features. Instead, you will find such information in the other chapters of this documentation. The IAR user documentation uses the terms described in this section when referring to these concepts.

These topics are covered:

- C-SPY and target systems
- The debugger
- The target system
- The application
- C-SPY debugger systems
- The ROM-monitor program
- Third-party debuggers
- C-SPY plugin modules

## C-SPY AND TARGET SYSTEMS

You can use C-SPY to debug either a software target system or a hardware target system.

This figure gives an overview of C-SPY and possible target systems:

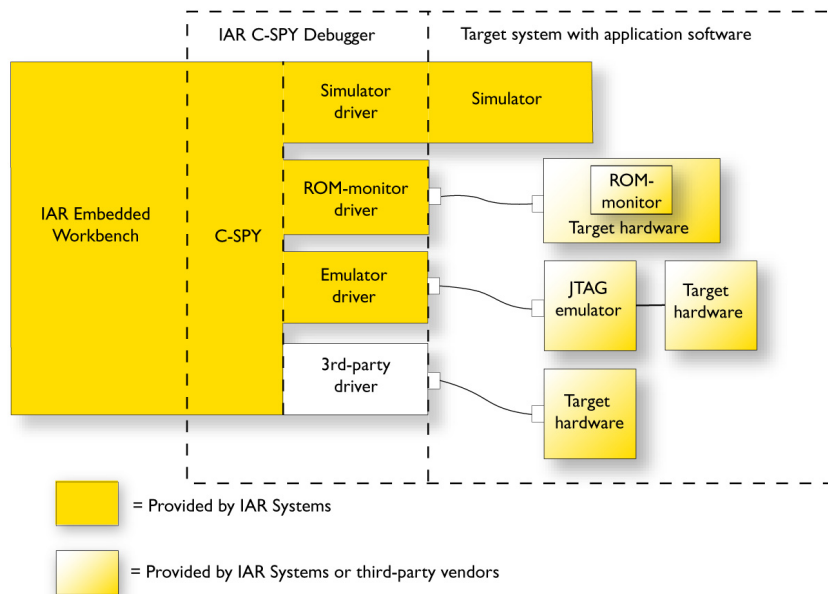

## THE DEBUGGER

The debugger, for instance C-SPY, is the program that you use for debugging your applications on a target system.

## THE TARGET SYSTEM

The target system is the system on which you execute your application when you are debugging it. The target system can consist of hardware, either an evaluation board or your own hardware design. It can also be completely or partially simulated by software. Each type of target system needs a dedicated C-SPY driver.

## THE APPLICATION

A user application is the software you have developed and which you want to debug using C-SPY.

## C-SPY DEBUGGER SYSTEMS

C-SPY consists of both a general part which provides a basic set of debugger features, and a target-specific back end. The back end consists of two components: a processor module—one for every microcontroller, which defines the properties of the microcontroller, and a *C-SPY driver*. The C-SPY driver is the part that provides communication with and control of the target system. The driver also provides the user interface—menus, windows, and dialog boxes—to the functions provided by the target system, for instance, special breakpoints.

Typically, there are three main types of C-SPY drivers:

- Simulator driver
- ROM-monitor driver
- Emulator driver

C-SPY is available with a simulator driver, and depending on your product package, optional drivers for hardware debugger systems. For an overview of the available C-SPY drivers and the functionality provided by each driver, see *C-SPY drivers overview*, page 45.

## THE ROM-MONITOR PROGRAM

The ROM-monitor program is a piece of firmware that is loaded to non-volatile memory on your target hardware—it runs in parallel with your application. The ROM-monitor communicates with the debugger and provides services needed for debugging the application, for instance stepping and breakpoints.

## THIRD-PARTY DEBUGGERS

You can use a third-party debugger together with the IAR toolchain as long as the third-party debugger can read ELF/DWARF, Intel-extended, or Motorola. For information about which format to use with a third-party debugger, see the user documentation supplied with that tool.

## C-SPY PLUGIN MODULES

C-SPY is designed as a modular architecture with an open SDK that can be used for implementing additional functionality to the debugger in the form of plugin modules. These modules can be seamlessly integrated in the IDE.

Plugin modules are provided by IAR, or can be supplied by third-party vendors. Examples of such modules are:

- The various C-SPY drivers for debugging using certain debug systems.
- RTOS plugin modules for support for real-time OS aware debugging.



- C-SPYLink that bridges IAR Visual State and IAR Embedded Workbench to make true high-level state machine debugging possible directly in C-SPY, in addition to the normal C level symbolic debugging. For more information, see the documentation provided with IAR Visual State.

For more information about the C-SPY SDK, contact IAR.

---

## Execution modes

IAR Embedded Workbench for Arm supports the 32-bit and 64-bit Arm architectures by means of execution modes.

**In 32-bit mode** refers to using IAR Embedded Workbench for Arm configured to generate and debug code for the T32/T and A32 instruction sets, either on an Armv4/5/6/7 core or in the AArch32 execution state on an Arm v8-A core. In 32-bit mode, you can use both the A32 and T32/T instruction sets and switch between them.

**In 64-bit mode** refers to using IAR Embedded Workbench for Arm configured to generate and debug code for the A64 instruction set in the AArch64 execution state on an Arm v8-A core. Code in 64-bit mode can call code in 32-bit mode, and that code can return back. However, the IAR translator tools do not support this switch being used in a single linked image. Switching between A32/T32/T code and A64 code must be performed by using several images. For example, an OS using 64-bit mode can start applications in either 64-bit or in 32-bit mode.

The AArch32 execution state is compatible with the Arm v7 architecture. The AArch32 execution state is emulated inside the AArch64 execution state.

---

## C-SPY drivers overview

At the time of writing this guide, the IAR C-SPY Debugger for Arm cores is available with drivers for these target systems and evaluation boards:

- Simulator
- CADI (Cycle Accurate Debug Interface)
- CMSIS-DAP probes
- The Renesas E2/E2Lite probes (with a Cortex-M device)
- GDB Server
- The GeneralPlus G+LINK probe
- I-jet and I-jet Trace debug probes
- J-Link/J-Trace probes

- Nuvoton Technology Corporation's Nu-Link debug adapter for Nuvoton's N76E Series MCUs. For information about the Nu-Link debug adapter, contact Nuvoton Technology Corporation.
- P&E Microcomputer Systems. For information about this driver, see the file `PEMicroSettings.pdf`, available in the `arm\doc` directory.
- ST-LINK JTAG/SWD probes (for ST Cortex-M devices only)
- TI MSP-FET probes
- TI Stellaris JTAG/SWD probes using FTDI or ICDI (for Stellaris Cortex devices only)
- TI XDS probes (XDS100v2, XDS100v3, XDS110, and XDS200)

**Note:** In addition to the drivers supplied with IAR Embedded Workbench, you can also load debugger drivers supplied by a third-party vendor, see *Third-Party Driver options*, page 630.

## DIFFERENCES BETWEEN THE C-SPY DRIVERS

This table summarizes the key differences between the Simulator, I-jet, J-Link/J-Trace, ST-LINK, TI XDS, CMSIS-DAP and TI MSP-FET drivers:

Feature	Simulator	I-jet	J-Link/ J-Trace	ST-LINK	TI XDS	CMSIS-DAP	TI MSP-FET
Code breakpoints	Yes	Yes	Yes	Yes	Yes	Yes	Yes
Data breakpoints	Yes <sup>3</sup>	Yes	Yes	Yes <sup>3</sup>	Yes	Yes	Yes
Interrupt logging <sup>1</sup>	Yes <sup>3</sup>	Yes	Yes	Yes <sup>3</sup>	Yes	—	—
Data logging <sup>1</sup>	Yes <sup>3</sup>	Yes	Yes	Yes <sup>3</sup>	Yes	—	—
State logging <sup>1</sup>	—	—	—	—	Yes	—	Yes
Call stack trace <sup>1</sup>	Yes <sup>3</sup>	Yes	Yes	—	—	—	—
Event logging <sup>1</sup>	—	Yes	Yes	Yes <sup>3</sup>	Yes	—	—
Live watch <sup>1</sup>	Yes	Yes	Yes	Yes <sup>3</sup>	Yes	Yes	—
Cycle counter <sup>1</sup>	Yes	Yes	Yes	Yes <sup>3</sup>	Yes	Yes	—
Code coverage <sup>1</sup>	Yes <sup>3</sup>	Yes	Yes	Yes <sup>3</sup>	Yes	Yes	—
Data coverage	Yes <sup>3</sup>	—	—	—	—	—	—
Function /instruction profiler <sup>1</sup>	Yes <sup>3</sup>	Yes	Yes	Yes <sup>3</sup>	Yes	—	—
Trace <sup>1</sup>	Yes <sup>3</sup>	Yes	Yes	Yes <sup>3</sup>	Yes	—	—

Table 3: Driver differences—Simulator, I-jet, J-Link/J-Trace, ST-LINK, TI XDS, etc

Feature	Simulator	I-jet	J-Link/ J-Trace	ST-LINK	TI XDS	CMSIS-DAP	TI MSP-FET
Multicore debugging <sup>1</sup>	Yes <sup>3</sup>	Yes	Yes	Yes <sup>4</sup>	—	Yes <sup>2</sup>	—
Performance monitoring <sup>1</sup>	—	Yes	Yes	—	—	—	—
Power debugging <sup>1</sup>	—	Yes	Yes	Yes <sup>3</sup>	Yes	—	Yes

Table 3: Driver differences—Simulator, I-jet, J-Link/J-Trace, ST-LINK, TI XDS, etc (Continued)

1 With specific requirements or restrictions, see the respective chapter in this guide.

2 Limited support.

3 Not for all cores and devices.

4 See the manufacturer's documentation.

This table summarizes the key differences between the Simulator and other supported hardware debugger drives—GDB Server, TI Stellaris, CADI, Nu-Link, E2/E2Lite, and G+LINK:

Feature	Simulator	GDB Server	TI Stellaris	CADI	Nu-Link	E2/E2Lite	G+LINK
Code breakpoints	Yes	Yes	Yes	Yes	Yes	Yes	Yes
Data breakpoints	Yes <sup>3</sup>	Yes	Yes	—	—	—	Yes
Interrupt logging <sup>1</sup>	Yes <sup>3</sup>	—	—	—	—	—	—
Data logging <sup>1</sup>	Yes <sup>3</sup>	—	—	—	—	—	—
State logging	—	—	—	—	—	—	—
Call stack trace <sup>1</sup>	Yes <sup>3</sup>	—	—	—	—	—	—
Event logging	—	—	—	—	—	—	—
Live watch	Yes	—	—	—	—	—	Yes
Cycle counter <sup>1</sup>	Yes	—	—	—	—	—	—
Code coverage <sup>1</sup>	Yes <sup>3</sup>	—	—	—	—	—	—
Data coverage	Yes <sup>3</sup>	—	—	—	—	—	—
Function/instruction profiler <sup>1</sup>	Yes <sup>3</sup>	—	—	—	—	—	—
Trace <sup>1</sup>	Yes <sup>3</sup>	—	—	—	—	—	—
Multicore debugging <sup>1</sup>	Yes <sup>3</sup>	—	—	—	—	—	—

Table 4: Driver differences—other drivers

Feature	Simulator	GDB Server	TI Stellaris	CADI	Nu-Link	E2/E2Lite	G+LINK
Performance monitoring	—	—	—	—	—	—	—
Power debugging	—	—	—	—	—	—	—

Table 4: Driver differences—other drivers (Continued)

1 With specific requirements or restrictions, see the respective chapter in this guide.

2 Limited support.

3 Not for all cores and devices.

## The IAR C-SPY Simulator

The C-SPY simulator simulates the functions of the target processor entirely in software, which means that you can debug the program logic long before any hardware is available. Because no hardware is required, it is also the most cost-effective solution for many applications.

### TWO SIMULATOR DRIVERS

The C-SPY simulator uses one of two debugger drivers. Which driver depends on which core or device you have selected for your application project. For some cores and devices, the C-SPY simulator uses the IAR C-SPY simulator driver, a feature-rich debugger driver. For other cores and devices, the C-SPY Simulator uses the Imperas Instruction Set Simulator, a very fast debugger driver. Both simulators are fully integrated into the C-SPY framework. You can see which one C-SPY is using by inspecting the debug log.

### SUPPORTED FEATURES

The C-SPY simulator supports:

- Instruction-level simulation
- Memory configuration and validation
- Interrupt simulation (not supported by the Imperas driver)
- Peripheral simulation (using the C-SPY macro system in conjunction with immediate breakpoints).

Simulating hardware instead of using a hardware debugging system means that some limitations do not apply, but that there are other limitations instead. For example:

- You can set an unlimited number of breakpoints in the simulator.

- When you stop executing your application, time actually stops in the simulator. When you stop application execution on a hardware debugging system, there might still be activities in the system. For example, peripheral units might still be active and reading from or writing to SFR ports.
- Application execution is significantly much slower in a simulator compared to when using a hardware debugging system. However, during a debug session, this might not necessarily be a problem.
- The simulator is not cycle accurate.
- Peripheral simulation is limited in the C-SPY Simulator and therefore the simulator is suitable mostly for debugging code that does not interact too much with peripheral units.

---

## The C-SPY hardware debugger drivers

C-SPY can connect to a hardware debugger using a C-SPY hardware debugger driver as an interface.

When a debug session is started, your application is automatically downloaded and programmed into target memory. You can disable this feature, if necessary.

These topics are covered:

- Communication overview
- Hardware installation
- USB driver installation

### COMMUNICATION OVERVIEW

There are two main communication setups, depending on the type of target system. Many of the Arm cores have built-in, on-chip debug support. Because the hardware debugger logic is built into the core, no ordinary ROM-monitor program or extra specific hardware is needed to make the debugging work, other than the debug probe. For some devices that do not have such built-in, on-chip debug support, there is instead a ROM-monitor debugger solution that can be used.

## Overview of a target system with a debug probe or emulator

Most target systems have an emulator, a debug probe or a debug adapter connected between the host computer and the evaluation board:

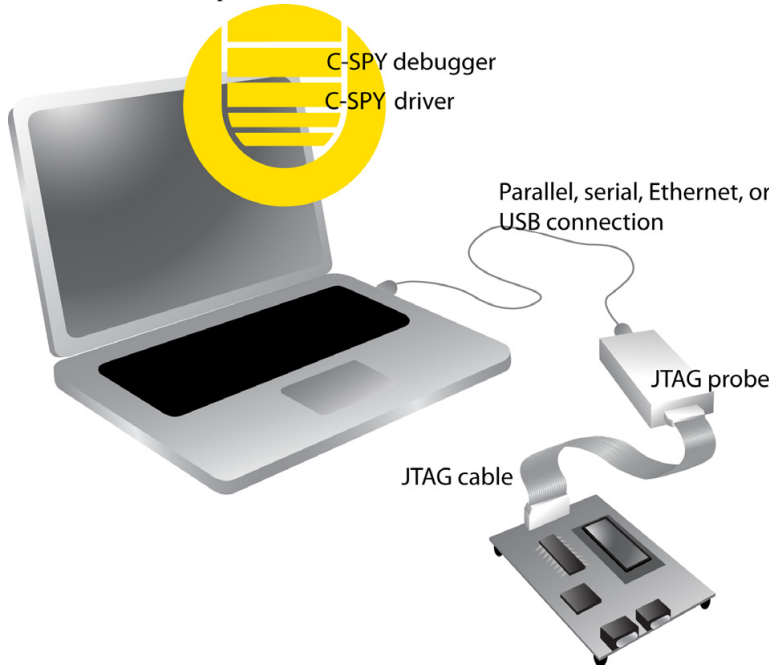

When a USB connection is used, a specific USB driver must be installed before you can use the probe over the USB port. You can find the driver on the IAR Embedded Workbench for Arm installation media.

## HARDWARE INSTALLATION

For best results, follow these steps.

### Recommended power-up sequence

For information about the hardware installation, see the documentation supplied with the target system from the manufacturer. The following power-up sequence is recommended to ensure proper communication between the target board, debug probe, and C-SPY:

- 1 Connect the probe to the target board.
- 2 Connect the USB cable to the debug probe.

- 3 Power up the debug probe, if it is not powered via USB.
- 4 Power up the target board, if it is not powered via the debug probe.
- 5 Start the C-SPY debug session.
- 6 If more than one debug probe is connected to your computer, the **Debug Probe Selection** dialog box is displayed. In the dialog box, select the probe to use and click **OK**. For more information, see *--drv\_communication*, page 534.

To give the probe a nickname, select the probe in the dialog box and click the **Edit Nickname** button. The nickname is saved locally on your computer and is available when opening other projects.

**Note:** The **Edit Nickname** button might not be available for the C-SPY driver you are using.

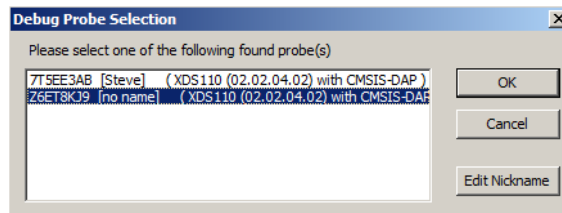

## USB DRIVER INSTALLATION

C-SPY needs a USB driver, which for some probes, is automatically installed. If the USB driver is not installed automatically, you will need to install it manually.

### Installing the I-jet USB driver

I-jet does not require any special driver software installation. Normally, all drivers for I-jet are automatically installed as part of the installation of IAR Embedded Workbench.

If you need to install the USB driver manually, navigate to `\arm\drivers\jet\USB\64-bit` (in the installation directory). Start the `dpinst.exe` application. This will install the USB driver.

### Installing the I-jet Trace USB driver

I-jet Trace does not require any special driver software installation. Normally, all drivers for I-jet Trace are automatically installed as part of the installation of IAR Embedded Workbench.

If you need to install the USB driver manually, navigate to `\arm\drivers\jet\USB\64-bit` (in the installation directory). Start the `dpinst.exe` application. This will install the USB driver.

The USB LED will flash twice after enumerating on the USB2 ports, and three times on USB3 ports.

### Installing the J-Link USB driver

Before you can use the J-Link JTAG probe over the USB port, the Segger J-Link USB driver must be installed.

- 1 Install IAR Embedded Workbench for Arm.
- 2 Use the USB cable to connect the computer and J-Link. Do not connect J-Link to the target board yet. The green LED on the front panel of J-Link will blink for a few seconds while Windows searches for a USB driver.

Run the `InstDrivers.exe` application, which is located in the product installation in the `arm\drivers\JLink` directory.

Once the initial setup is completed, you will not have to install the driver again.

**Note:** J-Link will continuously blink until the USB driver has established contact with the J-Link probe. When contact has been established, J-Link will start with a steady light to indicate that it is connected.

### Installing the ST-LINK USB driver for ST-LINK version 2

Before you can use the ST-LINK version 2 JTAG probe over the USB port, the ST-LINK USB driver must be installed.

- 1 Install IAR Embedded Workbench for Arm.
- 2 Use the USB cable to connect the computer and ST-LINK. Do not connect ST-LINK to the target board yet.

Because this is the first time ST-LINK and the computer are connected, Windows will open a dialog box and ask you to locate the USB driver. The USB driver can be found in the product installation in the `arm\drivers\ST-Link\Win_7-8` directory—`dpinst_amd64.exe`.

Once the initial setup is completed, you will not have to install the driver again.

### Installing the TI Stellaris USB driver

Before you can use the TI Stellaris JTAG interface using FTDI or ICDI over the USB port, the Stellaris USB driver must be installed.

- 1 Install IAR Embedded Workbench for Arm.



- 2 Use the USB cable to connect the computer to the TI board.

Because this is the first time the Stellaris JTAG interface and the computer are connected, Windows will open a dialog box and ask you to locate the USB driver. There are different USB drivers for FTDI and ICDI. The drivers can be found in the product installation in the `arm\drivers\StellarisFTDI` and the `arm\drivers\StellarisICDI` directories, respectively.

Once the initial setup is completed, you will not have to install the driver again.

### Installing the TI XDS USB driver

Before you can use the TI XDS JTAG interface over the USB port, the TI XDS package must be installed.

- 1 Install IAR Embedded Workbench for Arm.
- 2 Install the TI XDS package using the `run_installer.bat` file which can be found in the `arm\drivers\ti-xds\win64` directory. It is recommended to choose the suggested installation directory. See also *TI XDS — Setup*, page 627.
- 3 Use the USB cable to connect the computer to the TI board.

### Configuring the OpenOCD Server

For more information, see the `gdbserve_quickstart.html` file, available in the `arm\doc\infocenter` directory, or refer to the manufacturer's documentation.

### Installing the TI MSP-FET USB driver

Before you can use the TI MSP-FET driver, the TI MSP-FET USB driver must be installed.

- 1 Install IAR Embedded Workbench for Arm.
- 2 The USB driver can be found in the product installation in the `arm\drivers\ti-mspfet\USB_CDC` directory—`DPInst64.exe`.
- 3 Use the USB cable to connect to the TI MSP-FET probe.

### Installing the PE Micro USB driver

To install the USB driver for the PE Micro driver manually, navigate to the `arm\drivers\pemicro` directory and start the `PEDrivers_install.exe` application. This will install the USB driver. For information about this driver, see the file `PEMicroSettings.pdf`, available in the `arm\doc` directory.

### **Installing the Nu-Link USB driver**

To install the USB driver for the Nu-Link driver manually, navigate to the `arm\drivers\Nu-Link` directory and start the `Nu-Link_USB_Driver.exe` application. This will install the USB driver. For information about this driver, see the file `NuMicro Cortex-M IAR ICE driver user manual.pdf` available in the `arm\bin\Nu-Link` directory.

### **Installing the E2/E2Lite USB driver**

To install the USB driver for the Renesas E2 C-SPY driver manually, navigate to the `arm\drivers\RenesasE2` directory and start the `USB_Driver_x64_for_Renesas_MCU_Tools.exe` application. This will install the USB driver. For information about this probe, see the documentation from Renesas supplied with the probe.

# Getting started using C-SPY

- Setting up C-SPY
- Starting C-SPY
- Adapting for target hardware
- An overview of the debugger startup
- Reference information on starting C-SPY

---

## Setting up C-SPY

These tasks are covered:

- Setting up for debugging
- Executing from reset
- Using a setup macro file
- Selecting a device description file
- Loading plugin modules

### SETTING UP FOR DEBUGGING

- I Install a USB driver or some other communication driver, if your C-SPY driver requires it.

For more information, see:

- *Installing the I-jet USB driver*, page 51
- *Installing the I-jet Trace USB driver*, page 51
- *Installing the J-Link USB driver*, page 52
- *Installing the ST-LINK USB driver for ST-LINK version 2*, page 52
- *Installing the TI Stellaris USB driver*, page 52
- *Installing the TI XDS USB driver*, page 53
- *Configuring the OpenOCD Server*, page 53
- *Installing the TI MSP-FET USB driver*, page 53

- *Installing the PE Micro USB driver*, page 53
  - *Installing the Nu-Link USB driver*, page 54
  - *Installing the E2/E2Lite USB driver*, page 54
- 2 Before you start C-SPY, choose **Project>Options>Debugger>Setup** and select the C-SPY driver that matches your debugger system—simulator or hardware debugger system.
  - 3 In the **Category** list, select the appropriate C-SPY driver and make your settings. For information about these options, see *Debugger options*, page 583.
  - 4 Click **OK**.
  - 5 Choose **Tools>Options** to open the **IDE Options** dialog box:
    - Select **Debugger** to configure the debugger behavior
    - Select **Stack** to configure the debugger's tracking of stack usage.

For more information about these options, see the *IDE Project Management and Building Guide for Arm*. See also *Adapting for target hardware*, page 61.

## EXECUTING FROM RESET

The **Run to** option—available on the **Debugger>Setup** page—specifies a location you want C-SPY to run to when you start a debug session as well as after each reset. C-SPY will place a temporary breakpoint at this location and all code up to this point is executed before stopping at the location. Note that this temporary breakpoint is removed when the debugger stops, regardless of how. If you stop the execution before the **Run to** location has been reached, the execution will not stop at that location when you start the execution again.

The default location to run to is the `main` function. Type the name of the location if you want C-SPY to run to a different location. You can specify assembler labels or whatever can be evaluated to such, for instance function names.

If you leave the check box empty, the program counter will contain the regular hardware reset address at each reset. The reset address is set by C-SPY.

If no breakpoints are available when C-SPY starts, a warning message notifies you that single stepping will be required and that this is time consuming. You can then continue execution in single-step mode or stop at the first instruction. If you choose to stop at the first instruction, the debugger starts executing with the PC (program counter) at the default reset location instead of the location you typed in the **Run to** box.

**Note:** This message will never be displayed in the C-SPY simulator, where breakpoints are unlimited.

## USING A SETUP MACRO FILE

A setup macro file is a macro file that you choose to load automatically when C-SPY starts. You can define the setup macro file to perform actions according to your needs, using setup macro functions and system macros. Thus, if you load a setup macro file you can initialize C-SPY to perform actions automatically.

For more information about setup macro files and functions, see *Introduction to C-SPY macros*, page 427.

For an example of how to use a setup macro file, see *Initializing target hardware before C-SPY starts*, page 62.

### To register a setup macro file:

- 1 Before you start C-SPY, choose **Project>Options>Debugger>Setup**.
- 2 Select **Use macro file** and type the path and name of your setup macro file, for example `Setup.mac`. If you do not type a filename extension, the extension `mac` is assumed.

## SELECTING A DEVICE DESCRIPTION FILE

C-SPY uses device description files to handle device-specific information.

A default device description file—either an IAR-specific `ddf` file or a CMSIS System View Description file—is automatically used based on your project settings. If you want to override the default file, you must select your device description file. Device description files from IAR are provided in the `arm\config` directory and they have the filename extension `ddf`.

For more information about device description files, see *Adapting for target hardware*, page 61.

### To override the default device description file:

- 1 Before you start C-SPY, choose **Project>Options>Debugger>Setup**.
- 2 Select the **Override default** option, and choose a file using the **Device description file** browse button.

**Note:** You can easily view your device description files that are used for your project. Choose **Project>Open Device Description File** and select the file you want to view.

## LOADING PLUGIN MODULES

On the **Plugins** page you can specify C-SPY plugin modules to load and make available during debug sessions. Plugin modules can be provided by IAR, and by third-party suppliers. Contact your software distributor or IAR representative, or visit the IAR web site, for information about available modules.

For more information, see *Plugins*, page 592.

## Starting C-SPY

When you have set up the debugger, you are ready to start a debug session.

These tasks are covered:

- Starting a debug session
- Loading executable files built outside of the IDE
- Starting a debug session with source files missing
- Loading multiple debug images
- Editing in C-SPY windows

### STARTING A DEBUG SESSION

You can choose to start a debug session with or without loading the current executable file.



To start C-SPY and download the current executable file, click the **Download and Debug** button. Alternatively, choose **Project>Download and Debug**.



To start C-SPY without downloading the current executable file, click the **Debug without Downloading** button. Alternatively, choose **Project>Debug without Downloading**.

### LOADING EXECUTABLE FILES BUILT OUTSIDE OF THE IDE

You can also load C-SPY with an application that was built outside the IDE, for example applications built on the command line. To load an externally built executable file and to set build options you must first create a project for it in your workspace.

#### To create a project for an externally built file:

- 1 Choose **Project>Create New Project**, and specify a project name.
- 2 To add the executable file to the project, choose **Project>Add Files** and make sure to choose **All Files** in the file type drop-down list. Locate the executable file.
- 3  To start the executable file, click the **Download and Debug** button. The project can be reused whenever you rebuild your executable file.

The only project options that are meaningful to set for this kind of project are options in the **General Options** and **Debugger** categories. Make sure to set up the general project options in the same way as when the executable file was built.

## STARTING A DEBUG SESSION WITH SOURCE FILES MISSING

Normally, when you use the IAR Embedded Workbench IDE to edit source files, build your project, and start the debug session, all required files are available and the process works as expected.

However, if C-SPY cannot automatically find the source files, for example if the application was built on another computer, the **Get Alternative File** dialog box is displayed:

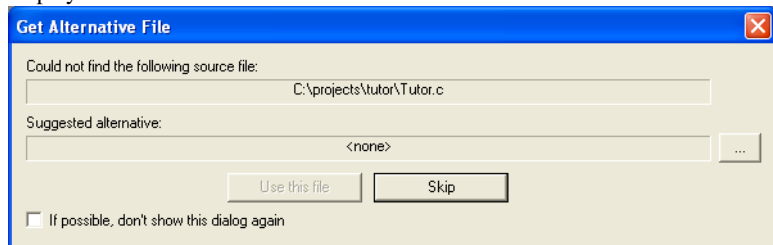

Typically, you can use the dialog box like this:

- The source files are not available—Select **If possible, don't show this dialog again** and then click **Skip**. C-SPY will assume that there is no source file available. The dialog box will not appear again, and the debug session will not try to display the source code.
- Alternative source files are available at another location—Specify an alternative source code file, select **If possible, don't show this dialog again**, and then click **Use this file**. C-SPY will assume that the alternative file should be used. The dialog box will not appear again, unless a file is needed for which there is no alternative file specified and which cannot be located automatically.

If you restart the IAR Embedded Workbench IDE, the **Get Alternative File** dialog box will be displayed again once even if you have selected **If possible, don't show this dialog again**. This gives you an opportunity to modify your previous settings.

For more information, see *Get Alternative File dialog box*, page 73.

## LOADING MULTIPLE DEBUG IMAGES

Normally, a debuggable application consists of a single file that you debug. However, you can also load additional debug files (debug images). This means that the complete program consists of several debug images.

Typically, this is useful if you want to debug your application in combination with a prebuilt ROM image that contains an additional library for some platform-provided features. The ROM image and the application are built using separate projects in the IAR Embedded Workbench IDE and generate separate output files.

If more than one debug image has been loaded, you will have access to the combined debug information for all the loaded debug images. In the **Images** window you can choose whether you want to have access to debug information for a single debug image or for all images.

### To load additional debug images at C-SPY startup:

- 1 Choose **Project>Options>Debugger>Images** and specify up to three additional debug images to be loaded. For more information, see *Images*, page 587.
- 2 Start the debug session.

To load additional debug images at a specific moment:

Use the `__loadImage` system macro and execute it using either one of the methods described in *Using C-SPY macros*, page 429.

To display a list of loaded debug images:

Choose **Images** from the **View** menu. The **Images** window is displayed, see *Images window*, page 72.

## EDITING IN C-SPY WINDOWS

You can edit the contents of these windows:

- **Memory** window
- **Symbolic Memory** window
- **Registers** window
- **Register User Groups Setup** window
- **Auto** window
- **Watch** window
- **Locals** window
- **Statics** window
- **Live Watch** window
- **Quick Watch** window

Use these keyboard keys to edit the contents of these windows:

<b>Enter</b>	Makes an item editable and saves the new value.
<b>Esc</b>	Cancels a new value.

In windows where you can edit the **Expression** field and in the **Quick Watch** window, you can specify the number of elements to be displayed in the field by adding a semicolon followed by an integer. For example, to display only the three first elements



of an array named `myArray`, or three elements in sequence starting with the element pointed to by a pointer, write:

```
myArray;3
```

To display three elements pointed to by `myPtr`, `myPtr+1`, and `myPtr+2`, write:

```
myPtr;3
```

Optionally, add a comma and another integer that specifies which element to start with. For example, to display elements 10–14, write:

```
myArray;5,10
```

To display `myPtr+10`, `myPtr+11`, `myPtr+12`, `myPtr+13`, and `myPtr+14`, write:

```
myPtr;5,10
```

**Note:** For pointers, there are no built-in limits on displayed element count, and no validation of the pointer value.

---

## Adapting for target hardware

These tasks are covered:

- Modifying a device description file
- Initializing target hardware before C-SPY starts
- Remapping memory
- Using predefined C-SPY macros for device support
- Debug authentication

See also *Memory configuration for C-SPY hardware debugger drivers*, page 166.

### MODIFYING A DEVICE DESCRIPTION FILE

C-SPY uses device description files provided with the product to handle several of the target-specific adaptations, see *Selecting a device description file*, page 57. Device description files contain device-specific information such as:

- Definitions of registers in peripheral units and groups of these.
- Interrupt definitions (for Cortex-M devices only), see *Interrupts*, page 401.

Normally, you do not need to modify the device description file. However, if the predefinitions are not sufficient for some reason, you can edit the file. Note, however, that the format of these descriptions might be updated in future upgrades of the product.

Make a copy of the device description file that best suits your needs, and modify it according to the description in the file. Reload the project to make the changes take effect.



If you are using an I-jet debug probe, and the modified device description file contains modified memory ranges, make sure to select the option **Use Factory** in the **Memory Configuration** dialog box.

The syntax of the device description files is described in the *IAR Embedded Workbench for Arm device description file format* guide (EWARM\_DDFFormat.pdf) located in the arm\doc directory.

For information about how to load a device description file, see *Selecting a device description file*, page 57.

## INITIALIZING TARGET HARDWARE BEFORE C-SPY STARTS

You can use C-SPY macros to initialize target hardware before C-SPY starts. For example, if your hardware uses external memory that must be enabled before code can be downloaded to it, C-SPY needs a macro to perform this action before your application can be downloaded.

- 1 Create a new text file and define your macro function.

By using the built-in `execUserPreload` setup macro function, your macro function will be executed directly after the communication with the target system is established but before C-SPY downloads your application.

For example, a macro that enables external SDRAM could look like this:

```
/* Your macro function. */
enableExternalSDRAM()
{
    __message "Enabling external SDRAM\n";
    __writeMemory32(...);
}

/* Setup macro determines time of execution. */
execUserPreload()
{
    enableExternalSDRAM();
}
```

- 2 Save the file with the filename extension `mac`.
- 3 Before you start C-SPY, choose **Project>Options>Debugger** and click the **Setup** tab.
- 4 Select the **Use macro file** option, and choose the macro file you just created.

Your setup macro will now be loaded during the C-SPY startup sequence.

## REMAPPING MEMORY

A common feature of many Arm-based processors is the ability to remap memory. After a reset, the memory controller typically maps address zero to non-volatile memory, such as flash. By configuring the memory controller, the system memory can be remapped to place RAM at zero and non-volatile memory higher up in the address map. By doing this, the exception table will reside in RAM and can be easily modified when you download code to the target hardware.

You must configure the memory controller before you download your application code. You can do this best by using a C-SPY macro function that is executed before the code download takes place—`execUserPreload`. The macro function `__writeMemory32` will perform the necessary initialization of the memory controller.

The following example illustrates a macro used for remapping memory on the Microchip AT91SAM7S256 chip, similar mechanisms exist in processors from other Arm vendors.

```
execUserPreload()
{
    // REMAP command
    // Writing 1 to MC_RCR (MC Remap Control Register)
    // will toggle remap bit.
    __writeMemory32(0x00000001, 0xFFFFF00, "Memory");
}
```

**Note:** The setup macro `execUserReset` might have to be defined in the same way to reinitialize the memory mapping after a C-SPY reset. This can be needed if you have set up your hardware debugger system to do a hardware reset on C-SPY reset, for example by adding `__hwReset` to the `execUserReset` macro.

For instructions on how to install a macro file in C-SPY, see *Registering and executing using setup macros and setup files*, page 431. For information about the macro functions used, see *Reference information on C-SPY system macros*, page 444.

## USING PREDEFINED C-SPY MACROS FOR DEVICE SUPPORT

For some Arm devices, there are predefined C-SPY macros available for specific device support, typically provided by the chip manufacturer. These macros are useful for performing certain device-specific tasks,

You can easily access and execute these macros using the **Macro Quicklaunch** window.

## DEBUG AUTHENTICATION

The purpose of debug authentication is to reduce the risk that an attacker uses debug capabilities to compromise the target system. IAR Embedded Workbench supports debug authentication using the open-source Secure Debug Manager (SDM) mechanism.

If the target device has been locked reversibly, the debug authentication mechanism unlocks the device for debugging, if you provide the correct credentials,

If authentication is enabled, it is performed when the debug session starts. The authentication is revoked by a target reset. The type of reset that revokes the authentication is hardware-specific.

When authentication is configured, IAR Embedded Workbench tries to determine whether it is actually needed so that the authentication procedure is not executed if the device is not locked. For example, if a power-on-reset is what revokes the authentication, restarting a debug session does not require a new authentication if no power cycle has taken place. If the device has never been locked, or has been unlocked in such a way that it does not go back to a locked state, no authentication is required either.

Any input dialog boxes displayed during the authentication process come from the SDM library used to drive the authentication process, not from IAR Embedded Workbench.

The SDM mechanism requires a library that implements the authentication protocol in terms of the SDM interface.

**Note:** Authentication is only available if the hardware supports it, if the correct library, corresponding to the hardware, is used, and if the hardware debugger driver supports it.

---

## An overview of the debugger startup

To make it easier to understand and follow the startup flow, the following figures show the flow of actions performed by C-SPY, and by the target hardware, as well as the execution of any predefined C-SPY setup macros. There is one figure for debugging code located in flash and one for debugging code located in RAM.

These topics are covered:

- Debugging code in flash
- Debugging code in RAM

For more information about C-SPY system macros, see the chapter *C-SPY macros* in this guide.

## DEBUGGING CODE IN FLASH

This figure illustrates the debugger startup when debugging code in flash memory:

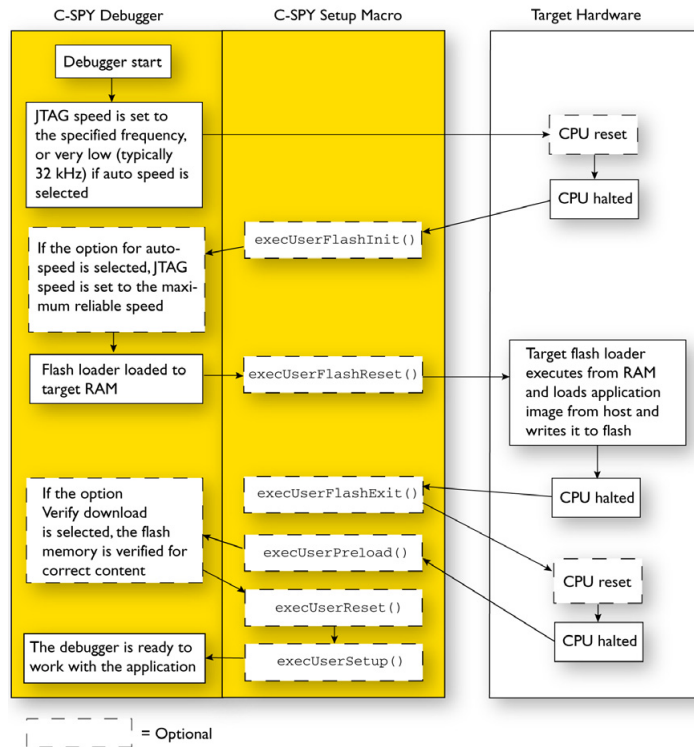

## DEBUGGING CODE IN RAM

This figure illustrates the debugger startup when debugging code in RAM:

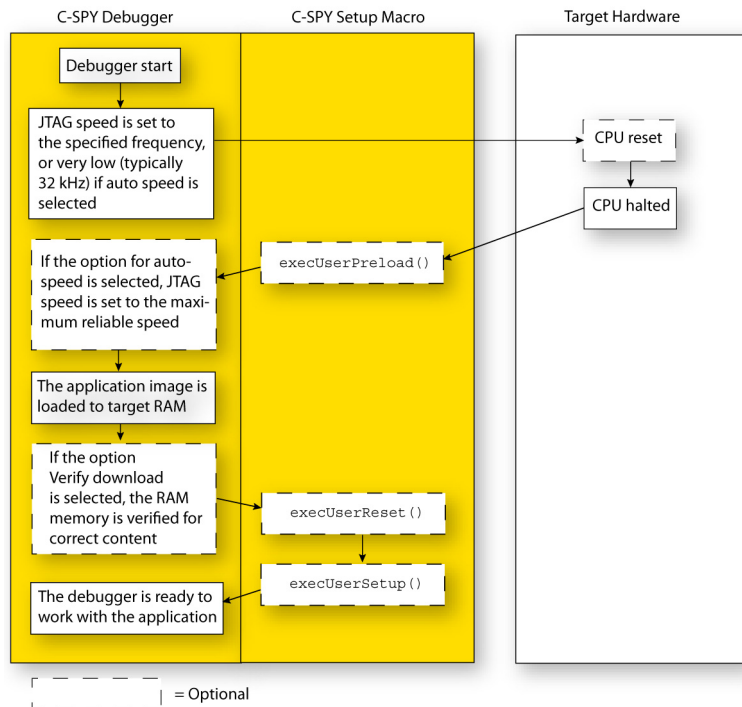

## Reference information on starting C-SPY

Reference information about:

- *C-SPY Debugger main window*, page 67
- *Images window*, page 72
- *Get Alternative File dialog box*, page 73

See also:

- Tools options for the debugger in the *IDE Project Management and Building Guide for Arm*.

## C-SPY Debugger main window

When you start a debug session, these debugger-specific items appear in the main IAR Embedded Workbench IDE window:

- A dedicated **Debug** menu with commands for executing and debugging your application
- Depending on the C-SPY driver you are using, a driver-specific menu, often referred to as the *Driver menu* in this documentation. Typically, this menu contains menu commands for opening driver-specific windows and dialog boxes.
- A special debug toolbar
- A special multicore debugging toolbar
- Several windows and dialog boxes specific to C-SPY

The C-SPY main window might look different depending on which components of the product installation you are using.

### Menu bar

These menus are available during a debug session:

#### **Debug**

Provides commands for executing and debugging the source application. Most of the commands are also available as icon buttons on the debug toolbar.

#### ***C-SPY driver menu***

Provides commands specific to a C-SPY driver. The driver-specific menu is only available when the driver is used. For information about the driver-specific menu commands, see *Reference information on C-SPY driver menus*, page 631.

#### **Disassembly**

Provides commands for controlling how the disassembler operates.

## Debug menu

The **Debug** menu is available during a debug session. The **Debug** menu provides commands for executing and debugging the source application. Most commands are also available as icon buttons on the debug toolbar.

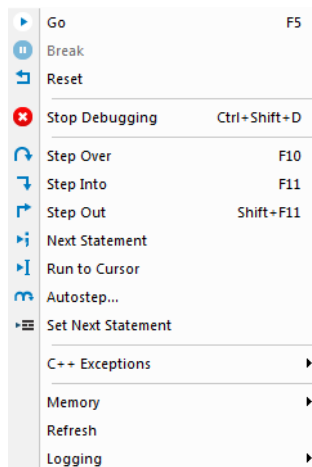

These commands are available:



### Go (F5)

Executes from the current statement or instruction until a breakpoint or program exit is reached.

**Note:** If you are using symmetric multicore debugging, the **Go** command starts only the core in focus.



### Break

Stops the application execution.

**Note:** If you are using symmetric multicore debugging, the **Break** command stops only the core in focus.



### Reset

Resets the target processor. Click the drop-down button to access a menu with additional commands.

**Enable Run to 'label'**, where *label* typically is `main`. Enables and disables the project option **Run to** without exiting the debug session. This menu command is only available if you have selected **Run to** in the **Options** dialog box.



*Reset strategies*, which contains a list of reset strategies supported by the C-SPY driver you are using. This means that you can choose a different reset strategy than the one used initially without exiting the debug session. Reset strategies are only available if the C-SPY driver you are using supports alternate reset strategies.



### Stop Debugging (Ctrl+Shift+D)

Stops the debugging session and returns you to the project manager.



### Step Over (F10)

Executes the next statement, function call, or instruction, without entering C or C++ functions or assembler subroutines.



### Step Into (F11)

Executes the next statement or instruction, or function call, entering C or C++ functions or assembler subroutines.



### Step Out (Shift+F11)

Executes from the current statement up to the statement after the call to the current function.



### Next Statement

Executes directly to the next statement without stopping at individual function calls.



### Run to Cursor

Executes from the current statement or instruction up to a selected statement or instruction.



### Autostep

Displays a dialog box where you can customize and perform autostepping, see *Autostep settings dialog box*, page 95.



### Set Next Statement

Moves the program counter directly to where the cursor is, without executing any source code. Note, however, that this creates an anomaly in the program flow and might have unexpected effects.

### C++ Exceptions>Break on Throw

Specifies that the execution shall break when the target application executes a `throw` statement.

To use this feature, your application must be built with the option **Library low-level interface implementation** selected and the language option **C++ With exceptions**.

**C++ Exceptions>Break on Uncaught Exception**

Specifies that the execution shall break when the target application throws an exception that is not caught by any matching `catch` statement.

To use this feature, your application must be built with the option **Library low-level interface implementation** selected and the language option **C++ With exceptions**.

**Memory>Save**

Displays a dialog box where you can save the contents of a specified memory area to a file, see *Memory Save dialog box*, page 176.

**Memory>Restore**

Displays a dialog box where you can load the contents of a file in, for example Intel-extended or Motorola s-record format to a specified memory zone, see *Memory Restore dialog box*, page 177.

**Refresh**

Refreshes the contents of all debugger windows. Because window updates are automatic, this is needed only in unusual situations, such as when target memory is modified in ways C-SPY cannot detect. It is also useful if code that is displayed in the **Disassembly** window is changed.

**Logging>Set Terminal I/O Log file**

Displays a dialog box where you can choose to log simulated target access communication to a file. You can select the destination of the log file. See *Terminal I/O Log File dialog box*, page 91.

**Disassembly menu**

The **Disassembly** menu is available when C-SPY is running. This menu provides commands for controlling how the disassembler operates.

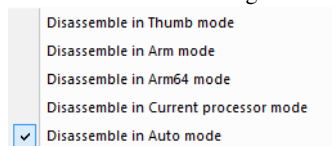

Use the commands on the menu to select which disassembly mode to use.

These commands are available:

**Disassemble in Thumb mode** Disassembles your application in Thumb mode.

**Disassemble in Arm mode** Disassembles your application in Arm mode.

<b>Disassemble in Arm64 mode</b>	Disassembles your application in 64-bit mode.
<b>Disassemble in Current processor mode</b>	Disassembles your application in the current processor mode.
<b>Disassemble in Auto mode</b>	Disassembles your application in automatic mode. This is the default option.

See also *Disassembly window*, page 83.

### C-SPY windows

Depending on the C-SPY driver you are using, these windows specific to C-SPY are available during a debug session:

- C-SPY Debugger main window
- Disassembly window
- Memory window
- Symbolic Memory window
- Registers window
- Watch window
- Locals window
- Auto window
- Live Watch window
- Quick Watch window
- Statics window
- Call Stack window
- Trace window
- Function Trace window
- Timeline window, see *Reference information on application timeline*, page 265
- Terminal I/O window
- Code Coverage window
- Function Profiler window
- Performance Monitoring window
- Images window
- Stack window
- Symbols window

Additional windows are available depending on which C-SPY driver you are using.

## Images window

The **Images** window is available from the **View** menu.

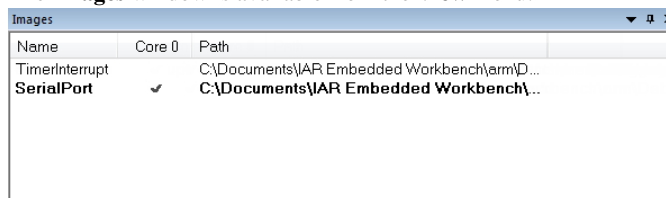

Name	Core 0	Path
TimerInterrupt		C:\Documents\JAR Embedded Workbench\arm\D...
SerialPort	✓	C:\Documents\JAR Embedded Workbench\...

This window lists all currently loaded debug images (debug files).

Normally, a source application consists of a single debug image that you debug. However, you can also load additional images. This means that the complete debuggable unit consists of several debug images. See also *Loading multiple debug images*, page 59.

### Requirements

Can be used with all C-SPY debugger drivers and debug probes.

### Display area

C-SPY can use debug information from one or more of the loaded debug images simultaneously. Double-click on a row to make C-SPY use debug information from that debug image. The current choices are highlighted.

This area lists the loaded debug images in these columns:

#### Name

The name of the loaded debug image.

#### Core *N*

Double-click in this column to toggle using debug information from the debug image when that core is in focus.

#### Path

The path to the loaded debug image.

### Related information

For related information, see:

- *Loading multiple debug images*, page 59
- *Images*, page 587
- *\_\_loadImage*, page 472

## Get Alternative File dialog box

The **Get Alternative File** dialog box is displayed if C-SPY cannot automatically find the source files to be loaded, for example if the application was built on another computer.

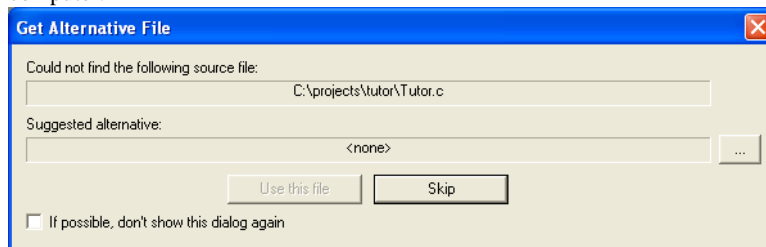

See also *Starting a debug session with source files missing*, page 59.

### Could not find the following source file

The missing source file.

### Suggested alternative

Specify an alternative file.

### Use this file

After you have specified an alternative file, **Use this file** establishes that file as the alias for the requested file. Note that after you have chosen this action, C-SPY will automatically locate other source files if these files reside in a directory structure similar to the first selected alternative file.

The next time you start a debug session, the selected alternative file will be preloaded automatically.

### Skip

C-SPY will assume that the source file is not available for this debug session.

### If possible, don't show this dialog again

Instead of displaying the dialog box again for a missing source file, C-SPY will use the previously supplied response.

### Related information

For related information, see *Starting a debug session with source files missing*, page 59.



# Executing your application

- Introduction to application execution
- Reference information on application execution

---

## Introduction to application execution

These topics are covered:

- Briefly about application execution
- Source and disassembly mode debugging
- Single stepping
- Troubleshooting slow stepping speed
- Running the application
- Highlighting
- Viewing the call stack
- Terminal input and output
- Debug logging

### **BRIEFLY ABOUT APPLICATION EXECUTION**

C-SPY allows you to monitor and control the execution of your application. By single-stepping through it, and setting breakpoints, you can examine details about the application execution, for example the values of variables and registers. You can also use the call stack to step back and forth in the function call chain.

The terminal I/O and debug log features let you interact with your application.

You can find commands for execution on the **Debug** menu and on the toolbar.

### **SOURCE AND DISASSEMBLY MODE DEBUGGING**

C-SPY allows you to switch between source mode and disassembly mode debugging as needed.

Source debugging provides the fastest and easiest way of developing your application, without having to worry about how the compiler or assembler has implemented the code. In the editor windows you can execute the application one statement at a time while monitoring the values of variables and data structures.

Disassembly mode debugging lets you focus on the critical sections of your application, and provides you with precise control of the application code. You can open a disassembly window which displays a mnemonic assembler listing of your application based on actual memory contents rather than source code, and lets you execute the application exactly one machine instruction at a time.

Regardless of which mode you are debugging in, you can display registers and memory, and change their contents.

## SINGLE STEPPING

C-SPY allows more stepping precision than most other debuggers because it is not line-oriented but statement-oriented. The compiler generates detailed stepping information in the form of *step points* at each statement, and at each function call. That is, source code locations where you might consider whether to execute a step into or a step over command. Because the step points are located not only at each statement but also at each function call, the step functionality allows a finer granularity than just stepping on statements.

There are several factors that can slow down the stepping speed. If you find it too slow, see *Troubleshooting slow stepping speed*, page 78 for some tips.

### The step commands

There are four step commands:

- **Step Into**
- **Step Over**
- **Next Statement**
- **Step Out**

Using the **Autostep settings** dialog box, you can automate the single stepping. For more information, see *Autostep settings dialog box*, page 95.

If your application contains an exception that is caught outside the code which would normally be executed as part of a step, C-SPY terminates the step at the `catch` statement.



Consider this example and assume that the previous step has taken you to the  $f(i)$  function call (highlighted):

```
extern int g(int);
int f(int n)
{
    value = g(n-1) + g(n-2) + g(n-3);
    return value;
}
int main()
{
    ...
    f(i);
    value ++;
}
```



### Step Into

While stepping, you typically consider whether to step into a function and continue stepping inside the function or subroutine. The **Step Into** command takes you to the first step point within the subroutine  $g(n-1)$ :

```
extern int g(int);
int f(int n)
{
    value = g(n-1) + g(n-2) + g(n-3);
    return value;
}
```

The **Step Into** command executes to the next step point in the normal flow of control, regardless of whether it is in the same or another function.



### Step Over

The **Step Over** command executes to the next step point in the same function, without stopping inside called functions. The command would take you to the  $g(n-2)$  function call, which is not a statement on its own but part of the same statement as  $g(n-1)$ . Thus, you can skip uninteresting calls which are parts of statements and instead focus on critical parts:

```
extern int g(int);
int f(int n)
{
    value = g(n-1) + g(n-2) + g(n-3);
    return value;
}
```



### Next Statement

The **Next Statement** command executes directly to the next statement, in this case `return value`, allowing faster stepping:

```
extern int g(int);
int f(int n)
{
    value = g(n-1) + g(n-2) + g(n-3);
    return value;
}
```



### Step Out

When inside the function, you can—if you wish—use the **Step Out** command to step out of it before it reaches the exit. This will take you directly to the statement immediately after the function call:

```
extern int g(int);
int f(int n)
{
    value = g(n-1) + g(n-2) + g(n-3);
    return value;
}
int main()
{
    ...
    f(i);
    value ++;
}
```

The possibility of stepping into an individual function that is part of a more complex statement is particularly useful when you use C code containing many nested function calls. It is also very useful for C++, which tends to have many implicit function calls, such as constructors, destructors, assignment operators, and other user-defined operators.

This detailed stepping can in some circumstances be either invaluable or unnecessarily slow. For this reason, you can also step only on statements, which means faster stepping.

## TROUBLESHOOTING SLOW STEPPING SPEED

If you find that stepping speed is slow, these troubleshooting tips might speed up stepping:

- If you are using a hardware debugger system, keep track of how many hardware breakpoints that are used and make sure some of them are left for stepping.

Stepping in C-SPY is normally performed using breakpoints. When C-SPY performs a step command, a breakpoint is set on the next statement and the application executes until it reaches this breakpoint. If you are using a hardware debugger system, the number of hardware breakpoints—typically used for setting a stepping breakpoint in code that is located in flash/ROM memory—is limited. If you, for example, step into a `C switch` statement, breakpoints are set on each branch; this might consume several hardware breakpoints. If the number of available hardware breakpoints is exceeded, C-SPY switches into single stepping on assembly level, which can be very slow.

For more information, see *Breakpoints in the C-SPY hardware debugger drivers*, page 129 and *Breakpoint consumers*, page 130.

- Disable trace data collection, using the **Enable/Disable** button in both the **Trace** and the **Function Profiling** windows. Trace data collection might slow down stepping because the collected trace data is processed after each step. Note that it is not sufficient to just close the corresponding windows to disable trace data collection.
- Choose to view only a limited selection of SFR registers. You can choose between two alternatives. Either type `#SFR_name` (where `SFR_name` reflects the name of the SFR you want to monitor) in the **Watch** window, or create your own filter for displaying a limited group of SFRs in the **Registers** window. Displaying many SFR registers might slow down stepping because all registers must be read from the hardware after each step. See *Defining application-specific register groups*, page 167.
- Close the **Memory** and **Symbolic Memory** windows if they are open, because the visible memory must be read after each step and that might slow down stepping.
- Close any window that displays expressions such as **Watch**, **Live Watch**, **Locals**, **Statics** if it is open, because all these windows read memory after each step and that might slow down stepping.
- Close the **Stack** window if it is open. Choose **Tools>Options>Stack** and disable the **Enable graphical stack display and stack usage tracking** option if it is enabled.
- If possible, increase the communication speed between C-SPY and the target board/emulator.

## RUNNING THE APPLICATION



### Go

The **Go** command continues execution from the current position until a breakpoint or program exit is reached.

**Note:** If you are using symmetric multicore debugging, the **Go** command starts only the core in focus.



## Run to Cursor

The **Run to Cursor** command executes to the position in the source code where you have placed the cursor. The **Run to Cursor** command also works in the **Disassembly** window and in the **Call Stack** window.

## HIGHLIGHTING

At each stop, C-SPY highlights the corresponding C or C++ source or instruction with a green color, in the editor and the **Disassembly** window respectively. In addition, a green arrow appears in the editor window when you step on C or C++ source level, and in the **Disassembly** window when you step on disassembly level. This is determined by which of the windows is the active window. If none of the windows are active, it is determined by which of the windows was last active.

```
Tutor.c Utilities.c
void init_fib( void )
{
  int i = 45;
  root[0] = root[1] = 1;
  for ( i=2 ; i<MAX_FIB ; i++)
  {
```

For simple statements without function calls, the whole statement is typically highlighted. When stopping at a statement with function calls, C-SPY highlights the first call because this illustrates more clearly what **Step Into** and **Step Over** would mean at that time.

Occasionally, you will notice that a statement in the source window is highlighted using a pale variant of the normal highlight color. This happens when the program counter is at an assembler instruction which is part of a source statement but not exactly at a step point. This is often the case when stepping in the **Disassembly** window. Only when the program counter is at the first instruction of the source statement, the ordinary highlight color is used.

## Code coverage

From the context menu in the **Code Coverage** window, you can toggle highlight colors and icons in the editor window that show code coverage analysis for the source code, see *Code Coverage window*, page 308.

These are the colors and icons that are used:

- Red highlight color and a red diamond—the code range has not been executed.
- Green highlight color—100% of the code range has been executed.
- Yellow highlight color and a red diamond—parts of the code range have been executed.

This figure illustrates all three code coverage highlight colors:

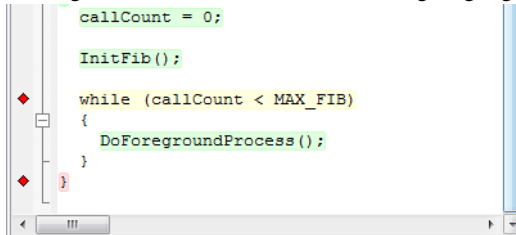

```

callCount = 0;
InitFib();
while (callCount < MAX_FIB)
{
    DoForegroundProcess();
}

```

## VIEWING THE CALL STACK

The compiler generates extensive call frame information. This allows C-SPY to show, without any runtime penalty, the complete function call chain at any time.



Typically, this is useful for two purposes:

- Determining in what context the current function has been called
- Tracing the origin of incorrect values in variables and in parameters, thus locating the function in the call chain where the problem occurred.

The **Call Stack** window shows a list of function calls, with the current function at the top. When you inspect a function in the call chain, the contents of all affected windows are updated to display the state of that particular call frame. This includes the editor, **Locals**, **Register**, **Watch**, and **Disassembly** windows. A function would normally not make use of all registers, so these registers might have undefined states and be displayed as dashes (---).

In the editor and **Disassembly** windows, a green highlight indicates the topmost, or current, call frame; a yellow highlight is used when inspecting other frames.

For your convenience, it is possible to select a function in the call stack and click the **Run to Cursor** command to execute to that function.

Assembler source code does not automatically contain any call frame information. To see the call chain also for your assembler modules, you can add the appropriate `CFI` assembler directives to the assembler source code. For more information, see the *IAR Assembler User Guide for Arm*.

**Note:** For highly optimized code, C-SPY might not be able to identify all calls. This means that for highly optimized code, the call stack is not entirely trustworthy.

## TERMINAL INPUT AND OUTPUT

Sometimes you might have to debug constructions in your application that use `stdin` and `stdout` without an actual hardware device for input and output. The **Terminal I/O**

window lets you enter input to your application, and display output from it. You can also direct terminal I/O to a file, using the **Terminal I/O Log Files** dialog box.



This facility is useful in two different contexts:

- If your application uses `stdin` and `stdout`
- For producing debug trace printouts

For more information, see *Terminal I/O window*, page 90 and *Terminal I/O Log File dialog box*, page 91.

## DEBUG LOGGING

The **Debug Log** window displays debugger output, such as diagnostic messages, macro-generated output, and information about trace.



It can sometimes be convenient to log the information to a file where you can easily inspect it, see *Debug Log window*, page 92. The two main advantages are:

- The file can be opened in another tool, for instance an editor, so you can navigate and search within the file for particularly interesting parts.
- The file provides history about how you have controlled the execution, for instance, which breakpoints that have been triggered etc.

---

## Reference information on application execution

Reference information about:

- *Disassembly window*, page 83
- *Call Stack window*, page 88
- *Terminal I/O window*, page 90
- *Terminal I/O Log File dialog box*, page 91
- *Debug Log window*, page 92
- *Fault exception viewer window*, page 93
- *Report Assert dialog box*, page 94
- *Autostep settings dialog box*, page 95

See also Terminal I/O options in the *IDE Project Management and Building Guide for Arm*.

## Disassembly window

The C-SPY **Disassembly** window is available from the **View** menu.

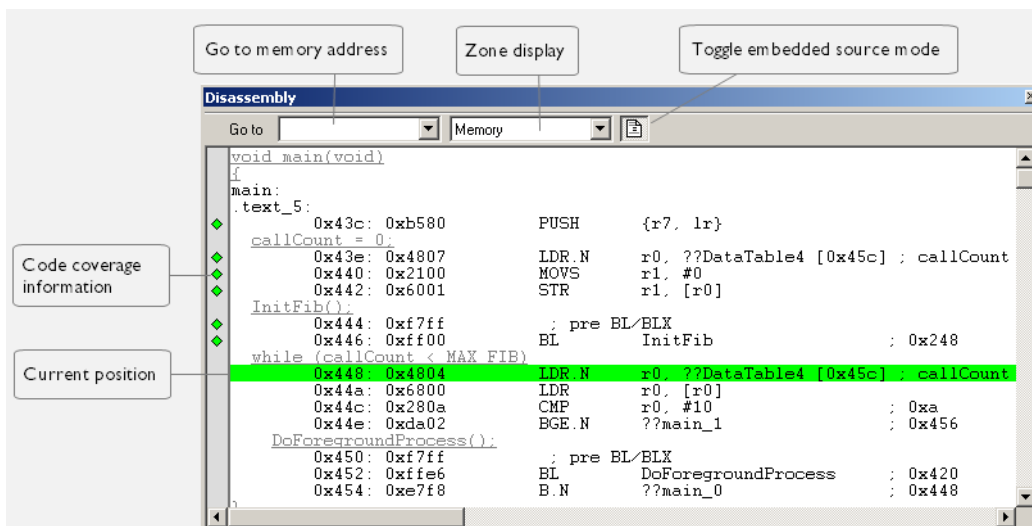

This window shows the application being debugged as disassembled application code.

**To change the default color of the source code in the Disassembly window:**

- 1 Choose **Tools>Options>Debugger**.
- 2 Set the default color using the **Source code color in disassembly window** option.



To view the corresponding assembler code for a function, you can select it in the editor window and drag it to the **Disassembly** window.

See also *Source and disassembly mode debugging*, page 75.

### Requirements

Can be used with all C-SPY debugger drivers and debug probes.

### Toolbar

The toolbar contains:

#### Go to

The memory location or symbol you want to view.

#### Zone

Selects a memory zone, see *C-SPY memory zones*, page 165.

**Toggle Mixed-Mode**

Toggles between displaying only disassembled code or disassembled code together with the corresponding source code. Source code requires that the corresponding source file has been compiled with debug information.

**Display area**

The display area shows the disassembled application code. This area contains these graphic elements:

Green highlight color	Indicates the current position, that is the next assembler instruction to be executed. To move the cursor to any line in the <b>Disassembly</b> window, click the line. Alternatively, move the cursor using the navigation keys.
Yellow highlight color	Indicates a position other than the current position, such as when navigating between frames in the <b>Call Stack</b> window or between items in the <b>Trace</b> window.
Red dot	Indicates a breakpoint. Double-click in the gray left-side margin of the window to set a breakpoint. For more information, see <i>Breakpoints</i> , page 125.
Green diamond	Code coverage icon—indicates code that has been executed.
Red diamond	Code coverage icon—indicates code that has <i>not</i> been executed.
Red/yellow diamond (red top/yellow bottom)	Code coverage icon—indicates a branch that is <i>never</i> taken.
Red/yellow diamond (red left side/yellow right side)	Code coverage icon—indicates a branch that is <i>always</i> taken.

If instruction profiling has been enabled from the context menu, an extra column in the left-side margin appears with information about how many times each instruction has been executed. For debug probes that support it, C-SPY can capture full instruction trace in real time.



## Context menu

This context menu is available:

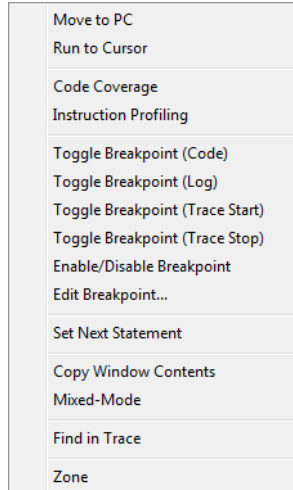

**Note:** The contents of this menu are dynamic, which means that the commands on the menu might depend on your product package.

These commands are available:

### Move to PC

Displays code at the current program counter location.

### Run to Cursor

Executes the application from the current position up to the line containing the cursor.

### Code Coverage

Displays a submenu that provides commands for controlling code coverage. This command is only enabled if the driver you are using supports it.

<b>Enable</b>	Toggles code coverage on or off.
<b>Show</b>	Toggles the display of code coverage on or off. Code coverage is indicated by a red, green, and red/yellow diamonds in the left margin.
<b>Clear</b>	Clears all code coverage information.

<b>Next Different Coverage &gt;</b>	Moves the insertion point to the next line in the window with a different code coverage status than the selected line.
<b>Previous Different Coverage &lt;</b>	Moves the insertion point to the closest preceding line in the window with a different code coverage status than the selected line.

### Instruction Profiling

Displays a submenu that provides commands for controlling instruction profiling. This command is only enabled if the driver you are using supports it.

<b>Enable</b>	Toggles instruction profiling on or off.
<b>Show</b>	Toggles the display of instruction profiling on or off. For each instruction, the left-side margin displays how many times the instruction has been executed.
<b>Clear</b>	Clears all instruction profiling information.

### Toggle Breakpoint (Code)

Toggles a code breakpoint. Assembler instructions and any corresponding label at which code breakpoints have been set are highlighted in red. For more information, see *Code breakpoints dialog box*, page 141.

### Toggle Breakpoint (Log)

Toggles a log breakpoint for trace printouts. Assembler instructions at which log breakpoints have been set are highlighted in red. For more information, see *Log breakpoints dialog box*, page 146.

### Toggle Breakpoint (Trace Start)

Toggles a Trace Start breakpoint. When the breakpoint is triggered, the trace data collection starts. Note that this menu command is only available if the C-SPY driver you are using supports trace. For more information, see *Trace Start Trigger breakpoint dialog box*, page 239.

### Toggle Breakpoint (Trace Stop)

Toggles a Trace Stop breakpoint. When the breakpoint is triggered, the trace data collection stops. Note that this menu command is only available if the C-SPY driver you are using supports trace. For more information, see *Trace Stop Trigger breakpoint dialog box*, page 240.

**Enable/Disable Breakpoint**

Enables and Disables a breakpoint. If there is more than one breakpoint at a specific line, all those breakpoints are affected by the **Enable/Disable** command.

**Edit Breakpoint**

Displays the breakpoint dialog box to let you edit the currently selected breakpoint. If there is more than one breakpoint on the selected line, a submenu is displayed that lists all available breakpoints on that line.

**Set Next Statement**

Sets the program counter to the address of the instruction at the insertion point.

**Copy Window Contents**

Copies the selected contents of the **Disassembly** window to the clipboard.

**Mixed-Mode**

Toggles between showing only disassembled code or disassembled code together with the corresponding source code. Source code requires that the corresponding source file has been compiled with debug information.

**Find in Trace**

Searches the contents of the **Trace** window for occurrences of the given location—the position of the insertion point in the source code—and reports the result in the **Find in Trace** window. This menu command requires support for Trace in the C-SPY driver you are using, see *Differences between the C-SPY drivers*, page 46.

**Zone**

Selects a memory zone, see *C-SPY memory zones*, page 165.

## Call Stack window

The **Call Stack** window is available from the **View** menu.

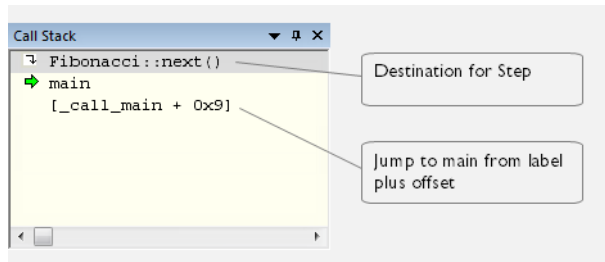

This window displays the C function call stack with the current function at the top. To inspect a function call, double-click it. C-SPY now focuses on that call frame instead.

If the next **Step Into** command would step to a function call, the name of the function is displayed in the gray bar at the top of the window. This is especially useful for implicit function calls, such as C++ constructors, destructors, and operators.

See also *Viewing the call stack*, page 81.

### Requirements

Can be used with all C-SPY debugger drivers and debug probes.

### Display area

Each entry in the display area is formatted in one of these ways:

`function(values)***`

A C/C++ function with debug information.

Provided that **Show Arguments** is enabled, *values* is a list of the current values of the parameters, or empty if the function does not take any parameters.

\*\*\*, if present, indicates that the function has been inlined by the compiler. For information about function inlining, see the *IAR C/C++ Development Guide for Arm*.

`[label + offset]`

An assembler function, or a C/C++ function without debug information.

`<exception_frame>`

An interrupt.

## Context menu

This context menu is available:

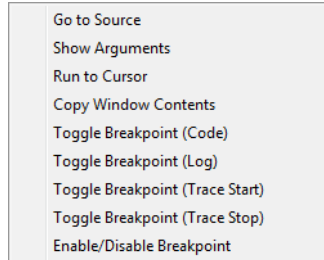

These commands are available:

### **Go to Source**

Displays the selected function in the **Disassembly** or editor windows.

### **Show Arguments**

Shows function arguments.

### **Run to Cursor**

Executes until return to the function selected in the call stack.

### **Copy Window Contents**

Copies the contents of the **Call Stack** window and stores them on the clipboard.

### **Toggle Breakpoint (Code)**

Toggles a code breakpoint.

### **Toggle Breakpoint (Log)**

Toggles a log breakpoint.

### **Toggle Breakpoint (Trace Start)**

Toggles a Trace Start breakpoint. When the breakpoint is triggered, trace data collection starts. Note that this menu command is only available if the C-SPY driver you are using supports it.

### **Toggle Breakpoint (Trace Stop)**

Toggles a Trace Stop breakpoint. When the breakpoint is triggered, trace data collection stops. Note that this menu command is only available if the C-SPY driver you are using supports it.

### **Enable/Disable Breakpoint**

Enables or disables the selected breakpoint.

## Terminal I/O window

The **Terminal I/O** window is available from the **View** menu.

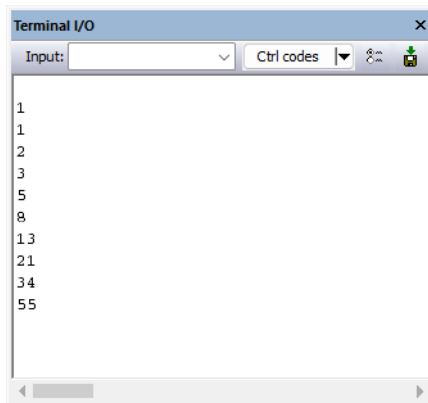

Use this window to enter input to your application, and display output from it.

### To use this window, you must:

- I Link your application with the option **Semihosted** or **IAR breakpoint**.

C-SPY will then direct `stdin`, `stdout` and `stderr` to this window. If the **Terminal I/O** window is closed, C-SPY will open it automatically when input is required, but not for output.

The following possibilities for using Terminal I/O in real time apply:

Device	Description
Cortex-M	The <code>stdout</code> of your application is routed via SWO. See <i>SWO Configuration dialog box</i> , page 225, specifically the <b>ITM Stimulus Port</b> option.
Arm7/Arm9, including Armxxx-S, and when using the C-SPY J-Link/J-Trace driver	DCC can be used for Terminal I/O output by adding the file <code>arm\src\debugger\dcc\DCC_Write.c</code> to your project. <code>DCC_write.c</code> overrides the library function <code>write</code> . Functions such as <code>printf</code> can then be used to output text to the <b>Terminal I/O</b> window. In this case, you can disable semihosting which means that the breakpoint it uses is freed for other purposes. To disable semihosting, choose <b>General Options&gt;Library Configuration&gt;Library low-level interface implementation&gt;None</b> .

Table 5: Terminal I/O in real time

See also *Terminal input and output*, page 81.

**Requirements**

Can be used with all C-SPY debugger drivers and debug probes.

**Toolbar****Input**

Type the text that you want to input to your application.

**Ctrl codes**

Opens a menu for input of special characters, such as EOF (end of file) and NUL.



Opens the **IDE Options** dialog box where you can set options for terminal I/O. For information about the options available in this dialog box, see *Terminal I/O options* in *IDE Project Management and Building Guide for Arm*.



Opens the **Terminal I/O Log File** dialog box, where you can configure and toggle logging on/off, see *Terminal I/O Log File dialog box*, page 91.

**Terminal I/O Log File dialog box**

The **Terminal I/O Log File** dialog box is available by choosing **Debug>Logging>Set Terminal I/O Log File**.

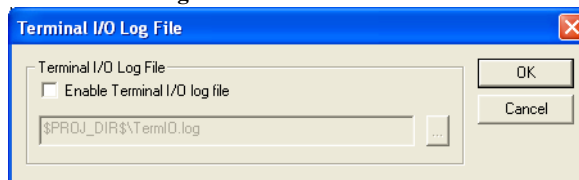

Use this dialog box to select a destination log file for terminal I/O from C-SPY.

See also *Terminal input and output*, page 81.

**Requirements**

Can be used with all C-SPY debugger drivers and debug probes.

**Terminal I/O Log File**

Controls the logging of terminal I/O. To enable logging of terminal I/O to a file, select **Enable Terminal I/O log file** and specify a filename. The default filename extension is `log`. A browse button is available for your convenience.

## Debug Log window

The Debug Log window is available by choosing **View>Messages>Debug Log**.

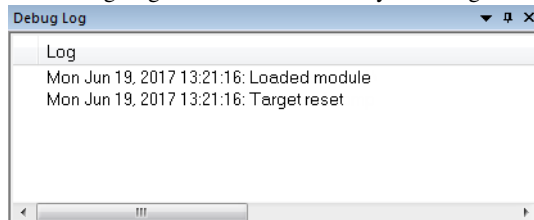

This window displays debugger output, such as diagnostic messages, macro-generated output, and information about trace. When opened, this window is, by default, grouped together with the other message windows, see *IDE Project Management and Building Guide for Arm*.

Double-click any rows in one of the following formats to display the corresponding source code in the editor window:

```
<path> (<row>) :<message>
<path> (<row>, <column>) :<message>
```

See also *Debug logging*, page 82.

### Requirements

Can be used with all C-SPY debugger drivers and debug probes.

### Context menu

This context menu is available:

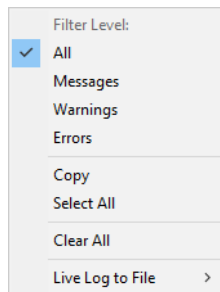

These commands are available:

#### All

Shows all messages sent by the debugging tools and drivers.



**Messages**

Shows all C-SPY messages.

**Warnings**

Shows warnings and errors.

**Errors**

Shows errors only.

**Copy**

Copies the contents of the window.

**Select All**

Selects the contents of the window.

**Clear All**

Clears the contents of the window.

**Live Log to File**

Displays a submenu with commands for writing the debug messages to a log file and setting filter levels for the log.

**Fault exception viewer window**

The **Fault exception viewer** window is available by choosing **View>Fault exception viewer**. The window is automatically opened when the execution stops and a fault exception was encountered.

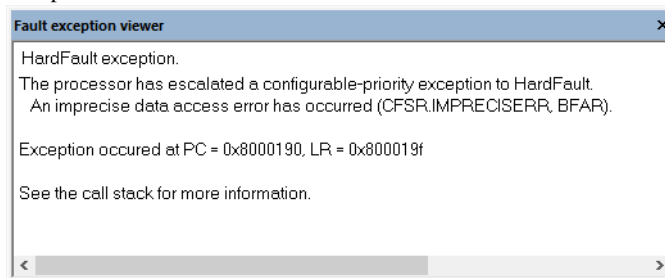
**Requirements**

Can be used with all C-SPY hardware debugger drivers and debug probes.

To display exception messages in this window, the selected device must be a Cortex-M device.

**Display area**

This area contains a description of the most recent fault exception that was encountered during application execution.

**Context menu**

This context menu is available:

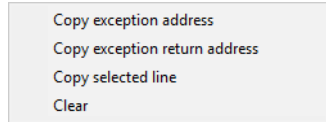

- Copy exception address
- Copy exception return address
- Copy selected line
- Clear

**Copy exception address**

Copies the address that the program counter, `PC`, had at the time of the exception. The address is copied to the clipboard.

**Copy exception return address**

Copies the address that the link register, `LR`, had at the time of the exception. The address is copied to the clipboard.

**Copy selected line**

Copies the selected line to the clipboard.

**Clear**

Clears the messages displayed in the **Fault exception viewer** window.

**Report Assert dialog box**

The **Report Assert** dialog box appears if you have a call to the `assert` function in your application source code, and the assert condition is false. In this dialog box you can choose how to proceed.

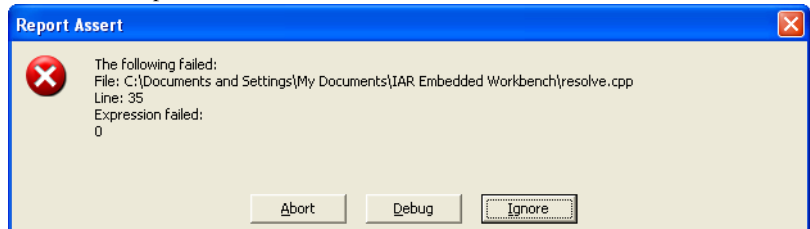

**To output the assert message as text:**

- 1 Add this function to your application source code:

```
void __aeabi_assert(char const * msg, char const *file, int
line)
{
    printf( "%s:%d %s -- assertion failed\n", file, line, msg );
    abort();
}
```

- 2 An assert message is displayed.

**Abort**

The application stops executing and the runtime library function `abort`, which is part of your application on the target system, will be called. This means that the application itself terminates its execution.

**Debug**

C-SPY stops the execution of the application and returns control to you.

**Ignore**

The assertion is ignored and the application continues to execute.

**Autostep settings dialog box**

The **Autostep settings** dialog box is available by choosing **Debug>Autostep**.

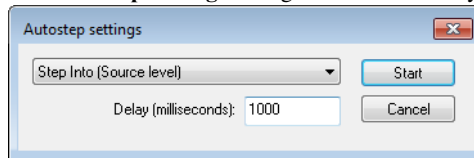

Use this dialog box to configure autostepping.

Select the step command you want to automate from the drop-down menu. The step will be performed with the specified interval. For a description of the available step commands, see *Single stepping*, page 76. You can stop the autostepping by clicking the Break button on the debug toolbar.

**Requirements**

Can be used with all C-SPY debugger drivers and debug probes.

**Delay (milliseconds)**

The delay between each step command in milliseconds. The step is repeated with this interval.

# Variables and expressions

- Introduction to working with variables and expressions
- Working with variables and expressions
- Reference information on working with variables and expressions

---

## Introduction to working with variables and expressions

This section introduces different methods for looking at variables and introduces some related concepts.

These topics are covered:

- Briefly about working with variables and expressions
- C-SPY expressions
- Limitations on variable information

### BRIEFLY ABOUT WORKING WITH VARIABLES AND EXPRESSIONS

There are several methods for looking at variables and calculating their values. These methods are suitable for basic debugging:

- **Tooltip watch**—in the editor window—provides the simplest way of viewing the value of a variable or more complex expressions. Just point at the variable with the mouse pointer. The value is displayed next to the variable.
- The **Auto** window displays a useful selection of variables and expressions in, or near, the current statement. The window is automatically updated when execution stops.
- The **Locals** window displays the local variables, that is, auto variables and function parameters for the active function. The window is automatically updated when execution stops.
- The **Watch** window allows you to monitor the values of C-SPY expressions and variables. The window is automatically updated when execution stops.
- The **Live Watch** window repeatedly samples and displays the values of expressions while your application is executing. Variables in the expressions must be statically located, such as global variables.
- The **Statics** window displays the values of variables with static storage duration. The window is automatically updated when execution stops.

- The **Macro Quicklaunch** window and the **Quick Watch** window give you precise control over when to evaluate an expression.
- The **Symbols** window displays all symbols with a static location, that is, C/C++ functions, assembler labels, and variables with static storage duration, including symbols from the runtime library.

These additional methods for looking at variables are suitable for more advanced analysis:

- The **Data Log** window and the **Data Log Summary** window display logs of accesses to up to four different memory locations you choose by setting data log breakpoints. Data logging can help you locate frequently accessed data. You can then consider whether you should place that data in more efficient memory.
- The **Event Log** window and the **Event Log Summary** window display *event logs* produced when the execution passes specific positions in your application code. The **Timeline** window graphically displays these event logs correlated to a common time-axis. Event logging can help you to analyze program flow and inspect data correlated to a certain position in your application code.

The Cortex ITM communication channels are used for passing events from a running application to the C-SPY Event log system. There are predefined preprocessor macros that you can use in your application source code. An Event log will be generated every time such macros are passed during program execution. You can pass a value with each event. Typically, this value can be either an identifier or the content of a variable or a register (for example, the stack pointer). The value can be written in 8, 16, or 32-bit format. Using a smaller size will reduce the bandwidth needed on the SWO wire. Events can be generated with or without an associated PC (program counter) value, the PC value makes it possible for the debugger to correlate the event to the executed code.

For more information about these windows, see *The application timeline*, page 257.

## C-SPY EXPRESSIONS

C-SPY expressions can include any type of C expression, except for calls to functions. The following types of symbols can be used in expressions:

- C/C++ symbols
- Assembler symbols (register names and assembler labels)
- C-SPY macro functions
- C-SPY macro variables

Expressions that are built with these types of symbols are called C-SPY expressions and there are several methods for monitoring these in C-SPY. Examples of valid C-SPY expressions are:

```
i + j
i = 42
myVar = cVar
cVar = myVar + 2
#asm_label
#R2
#PC32
my_macro_func(19)
```

If you have a static variable with the same name declared in several different functions, use the notation `function::variable` to specify which variable to monitor.

**Note:** On 64-bit architectures, the expression `#PC` becomes ambiguous in C-SPY macros. Therefore, when you debug a 64-bit MCU, you must use `#PC32` for AArch32 and `#PC64` for AArch64 in C-SPY macros. When debugging a 32-bit MCU, use `#PC`.

### C/C++ symbols

C symbols are symbols that you have defined in the C source code of your application, for instance variables, constants, and functions (functions can be used as symbols but cannot be executed). C symbols can be referenced by their names. Note that C++ symbols might implicitly contain function calls which are not allowed in C-SPY symbols and expressions.

**Note:** Some attributes available in C/C++, like `volatile`, are not fully supported by C-SPY. For example, this line will not be accepted by C-SPY:

```
sizeof(unsigned char volatile __memattr *)
```

However, this line will be accepted:

```
sizeof(unsigned char __memattr *)
```

### Assembler symbols

Assembler symbols can be assembler labels or registers, for example the program counter, the stack pointer, or other CPU registers. If a device description file is used, all memory-mapped peripheral units, such as I/O ports, can also be used as assembler symbols in the same way as the CPU registers. See *Modifying a device description file*, page 61.

Assembler symbols can be used in C-SPY expressions if they are prefixed by #.

Example	What it does
<code>#PC32++</code>	Increments the value of the program counter.
<code>myVar = #SP</code>	Assigns the current value of the stack pointer register to your C-SPY variable.
<code>myVar = #label</code>	Sets <code>myVar</code> to the value of an integer at the address of <code>label</code> .
<code>myPtr = &amp;#label7</code>	Sets <code>myPtr</code> to an <code>int *</code> pointer pointing at <code>label7</code> .

Table 6: C-SPY assembler symbols expressions

In case of a name conflict between a hardware register and an assembler label, hardware registers have a higher precedence. To refer to an assembler label in such a case, you must enclose the label in back quotes ` (ASCII character 0x60). For example:

Example	What it does
<code>#PC32</code>	Refers to the program counter.
<code>#`PC32`</code>	Refers to the assembler label <code>PC32</code> .

Table 7: Handling name conflicts between hardware registers and assembler labels

Which processor-specific symbols are available by default can be seen in the **Registers** window, using the CPU Registers register group. See *Registers window*, page 186.

## C-SPY macro functions

Macro functions consist of C-SPY macro variable definitions and macro statements which are executed when the macro is called.

For information about C-SPY macro functions and how to use them, see *Briefly about the macro language*, page 429.

## C-SPY macro variables

Macro variables are defined and allocated outside your application, and can be used in a C-SPY expression. In case of a name conflict between a C symbol and a C-SPY macro variable, the C-SPY macro variable will have a higher precedence than the C variable. Assignments to a macro variable assign both its value and type.

For information about C-SPY macro variables and how to use them, see *Reference information on the macro language*, page 434.

## Using sizeof

According to standard C, there are two syntactical forms of `sizeof`:

```
sizeof(type)
sizeof expr
```



The former is for types and the latter for expressions.

**Note:** In C-SPY, do not use parentheses around an expression when you use the `sizeof` operator. For example, use `sizeof x+2` instead of `sizeof (x+2)`.

## LIMITATIONS ON VARIABLE INFORMATION

The value of a C variable is valid only on step points, that is, the first instruction of a statement and on function calls. This is indicated in the editor window with a bright green highlight color. In practice, the value of the variable is accessible and correct more often than that.

When the program counter is inside a statement, but not at a step point, the statement or part of the statement is highlighted with a pale variant of the ordinary highlight color.

### Effects of optimizations

The compiler is free to optimize the application software as much as possible, as long as the expected behavior remains. The optimization can affect the code so that debugging might be more difficult because it will be less clear how the generated code relates to the source code. Typically, using a high optimization level can affect the code in a way that will not allow you to view a value of a variable as expected.

Consider this example:

```
myFunction()
{
    int i = 42;
    ...
    x = computer(i); /* Here, the value of i is known to C-SPY */
    ...
}
```

From the point where the variable `i` is declared until it is actually used, the compiler does not need to waste stack or register space on it. The compiler can optimize the code, which means that C-SPY will not be able to display the value until it is actually used. If you try to view the value of a variable that is temporarily unavailable, C-SPY will display the text:

```
Unavailable
```

If you need full information about values of variables during your debugging session, you should use the lowest optimization level during compilation, that is, **None**.

---

## Working with variables and expressions

These tasks are covered:

- Using the windows related to variables and expressions
- Viewing assembler variables

See also *Analyzing your application's timeline*, page 259.

### USING THE WINDOWS RELATED TO VARIABLES AND EXPRESSIONS

Where applicable, you can add, modify, and remove expressions, and change the display format in the windows related to variables and expressions.

To add a value you can also click in the dotted rectangle and type the expression you want to examine. To modify the value of an expression, click the **Value** field and modify its content. To remove an expression, select it and press the Delete key.



For text that is too wide to fit in a column—in any of these windows, except the **Trace** window—and thus is truncated, just point at the text with the mouse pointer and tooltip information is displayed.

Right-click in any of the windows to access the context menu which contains additional commands. Convenient drag-and-drop between windows is supported, except for in the **Locals** window, data logging windows, and the **Quick Watch** window where it is not relevant.

### VIEWING ASSEMBLER VARIABLES

An assembler label does not convey any type information at all, which means C-SPY cannot easily display data located at that label without getting extra information. To view data conveniently, C-SPY by default treats all data located at assembler labels as variables of type `int`. However, in the **Watch**, **Live Watch**, and **Quick Watch** windows, you can select a different interpretation to better suit the declaration of the variables.

In this figure, you can see four variables in the **Watch** window and their corresponding declarations in the assembler source file to the left:

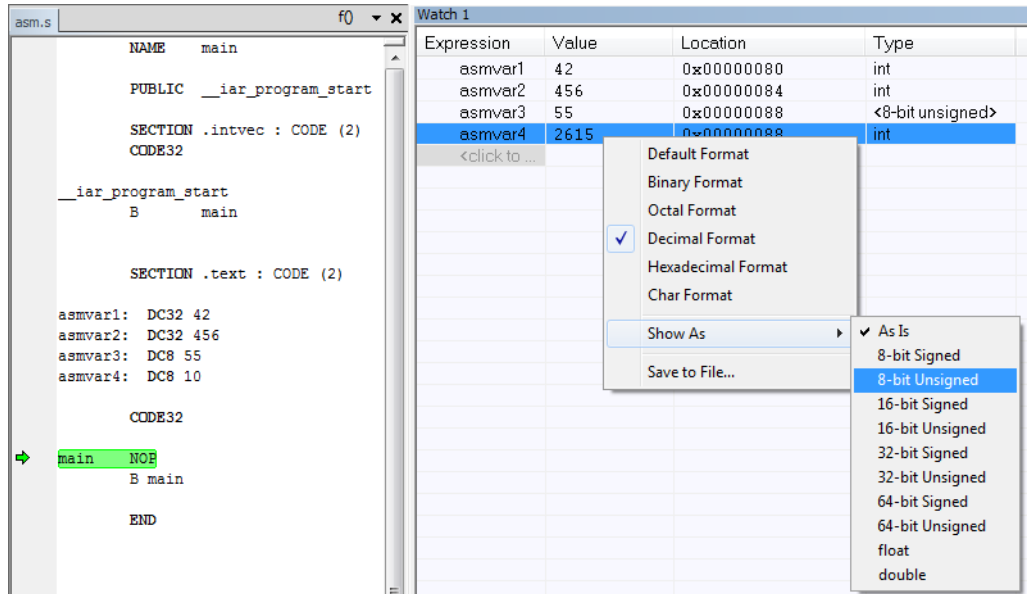

Note that `asmvar4` is displayed as an `int`, although the original assembler declaration probably intended for it to be a single byte quantity. From the context menu you can make C-SPY display the variable as, for example, an 8-bit unsigned variable. This has already been specified for the `asmvar3` variable.

## Reference information on working with variables and expressions

Reference information about:

- *Auto window*, page 104
- *Locals window*, page 106
- *Watch window*, page 109
- *Live Watch window*, page 112
- *Statics window*, page 115
- *Quick Watch window*, page 118
- *Symbols window*, page 121
- *Resolve Symbol Ambiguity dialog box*, page 124

See also:

- *Reference information on trace*, page 218 for trace-related reference information
- *Macro Quicklaunch window*, page 513

## Auto window

The **Auto** window is available from the **View** menu.

Expression	Value	Location	Type
NextCounter	NextCounter (0x40B)		void (__...
fib	1	Memory: 0xFEF74	uint32_t
GetFib	GetFib (0x141)		uint32_t(...
callCount	3	Memory: 0xFEFA8	signed int

This window displays a useful selection of variables and expressions in, or near, the current statement. Every time execution in C-SPY stops, the values in the **Auto** window are recalculated. Values that have changed since the last stop are highlighted in red.

See also *Editing in C-SPY windows*, page 60.

### Requirements

Can be used with all C-SPY debugger drivers and debug probes.

### Display area

This area contains these columns:

#### Expression

The name of the variable. This column is not editable.

A name in square brackets, for example `[fieldname]`, is either the name of a base class for a struct/class object or—if shown in gray and *italic*—a pointer to the full object when of a class type derived from the original class.

#### Value

The value of the variable. Values that have changed are highlighted in red.

Dragging text or a variable from another window and dropping it on the **Value** column will assign a new value to the variable in that row.

This column is editable.

#### Location

The location in memory where this variable is stored.

**Type**

The data type of the variable.

**Context menu**

This context menu is available:

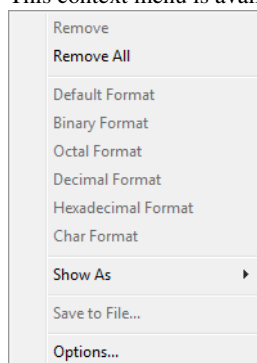

**Note:** The contents of this menu are dynamic and depend on which features that your combination of software and hardware supports. However, the list of menu commands below is complete and covers all possible commands.

These commands are available:

**Remove**

Removes the selected expression from the window.

**Remove All**

Removes all expressions listed in the window.

**Default Format****Binary Format****Octal Format****Decimal Format****Hexadecimal Format****Char Format**

Changes the display format of expressions. The display format setting affects different types of expressions in different ways. Your selection of display format is saved between debug sessions. These commands are available if a selected line in the window contains a variable.

The display format setting affects different types of expressions in these ways:

Variables	The display setting affects only the selected variable, not other variables.
Array elements	The display setting affects the complete array, that is, the same display format is used for each array element.
Structure fields	All elements with the same definition—the same field name and C declaration type—are affected by the display setting.

### Show As

Displays a submenu that provides commands for changing the default type interpretation of variables. The commands on this submenu are mainly useful for assembler variables—data at assembler labels—because these are, by default, displayed as integers. For more information, see *Viewing assembler variables*, page 102.

### Save to File

Saves content to a file in a tab-separated format.

### Options

Displays the **IDE Options** dialog box where you can set various options for C-SPY windows.

## Locals window

The **Locals** window is available from the **View** menu.

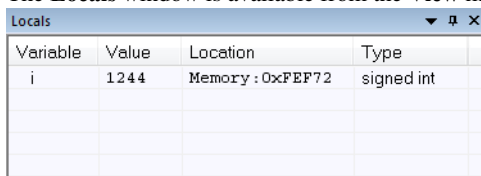

Variable	Value	Location	Type
i	1244	Memory : 0xPEF72	signed int

This window displays the local variables and parameters for the current function. Every time execution in C-SPY stops, the values in the window are recalculated. Values that have changed since the last stop are highlighted in red.

See also *Editing in C-SPY windows*, page 60.

### Requirements

Can be used with all C-SPY debugger drivers and debug probes.

## Display area

This area contains these columns:

### Variable

The name of the variable. This column is not editable.

A name in square brackets, for example `[fieldname]`, is either the name of a base class for a struct/class object or—if shown in gray and *italic*)—a pointer to the full object when of a class type derived from the original class.

### Value

The value of the variable. Values that have changed are highlighted in red.

Dragging text or a variable from another window and dropping it on the **Value** column will assign a new value to the variable in that row.

This column is editable.

### Location

The location in memory where this variable is stored.

### Type

The data type of the variable.

## Context menu

This context menu is available:

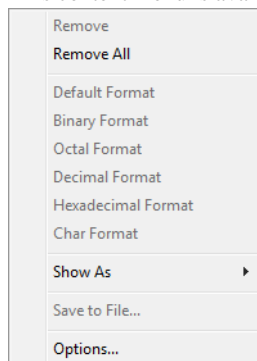

**Note:** The contents of this menu are dynamic and depend on which features that your combination of software and hardware supports. However, the list of menu commands below is complete and covers all possible commands.

These commands are available:

**Remove**

Removes the selected expression from the window.

**Remove All**

Removes all expressions listed in the window.

**Default Format**

**Binary Format**

**Octal Format**

**Decimal Format**

**Hexadecimal Format**

**Char Format**

Changes the display format of expressions. The display format setting affects different types of expressions in different ways. Your selection of display format is saved between debug sessions. These commands are available if a selected line in the window contains a variable.

The display format setting affects different types of expressions in these ways:

Variables	The display setting affects only the selected variable, not other variables.
Array elements	The display setting affects the complete array, that is, the same display format is used for each array element.
Structure fields	All elements with the same definition—the same field name and C declaration type—are affected by the display setting.

**Show As**

Displays a submenu that provides commands for changing the default type interpretation of variables. The commands on this submenu are mainly useful for assembler variables—data at assembler labels—because these are, by default, displayed as integers. For more information, see *Viewing assembler variables*, page 102.

**Save to File**

Saves content to a file in a tab-separated format.

**Options**

Displays the **IDE Options** dialog box where you can set various options for C-SPY windows.



## Watch window

The **Watch** window is available from the **View** menu.

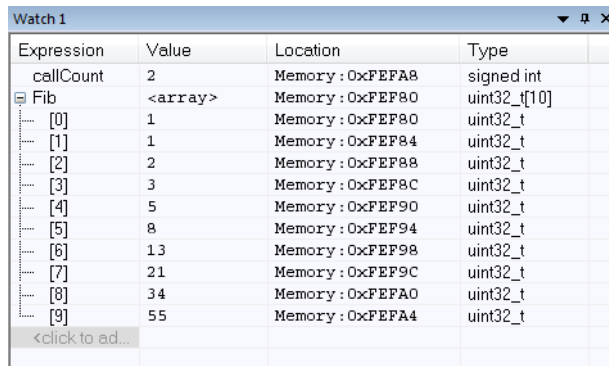

Expression	Value	Location	Type
callCount	2	Memory : 0xFEFA8	signed int
Fib	<array>	Memory : 0xFEFA0	uint32_t[10]
[0]	1	Memory : 0xFEFA0	uint32_t
[1]	1	Memory : 0xFEFA4	uint32_t
[2]	2	Memory : 0xFEFA8	uint32_t
[3]	3	Memory : 0xFEFAC	uint32_t
[4]	5	Memory : 0xFEFA0	uint32_t
[5]	8	Memory : 0xFEFA4	uint32_t
[6]	13	Memory : 0xFEFA8	uint32_t
[7]	21	Memory : 0xFEFAC	uint32_t
[8]	34	Memory : 0xFEFA0	uint32_t
[9]	55	Memory : 0xFEFA4	uint32_t
<click to ad...>			

Use this window to monitor the values of C-SPY expressions or variables. You can open up to four instances of this window, where you can view, add, modify, and remove expressions. Tree structures of arrays, structs, and unions are expandable, which means that you can study each item of these.

Every time execution in C-SPY stops, the values in the **Watch** window are recalculated. Values that have changed since the last stop are highlighted in red.



Be aware that expanding very large arrays can cause an out-of-memory crash. To avoid this, expansion is automatically performed in steps of 5000 elements.

See also *Editing in C-SPY windows*, page 60.

### Requirements

Can be used with all C-SPY debugger drivers and debug probes.

### Display area

This area contains these columns:

#### Expression

The name of the variable.

A name in square brackets, for example `[fieldname]`, is either the name of a base class for a struct/class object or—if shown in gray and *italic*—a pointer to the full object when of a class type derived from the original class.

#### Value

The value of the variable. Values that have changed are highlighted in red.

Dragging text or a variable from another window and dropping it on the **Value** column will assign a new value to the variable in that row.

This column is editable.

### Location

The location in memory where this variable is stored.

### Type

The data type of the variable.

### Context menu

This context menu is available:

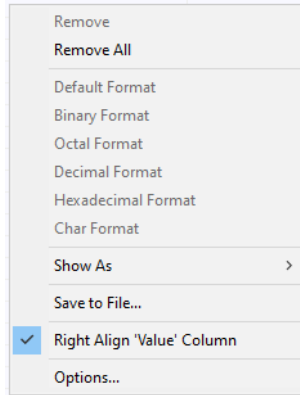

**Note:** The contents of this menu are dynamic and depend on which features that your combination of software and hardware supports. However, the list of menu commands below is complete and covers all possible commands.

These commands are available:

### Remove

Removes the selected expression from the window.

### Remove All

Removes all expressions listed in the window.

**Default Format****Binary Format****Octal Format****Decimal Format****Hexadecimal Format****Char Format**

Changes the display format of expressions. The display format setting affects different types of expressions in different ways. Your selection of display format is saved between debug sessions. These commands are available if a selected line in the window contains a variable.

The display format setting affects different types of expressions in these ways:

<b>Variables</b>	The display setting affects only the selected variable, not other variables.
<b>Array elements</b>	The display setting affects the complete array, that is, the same display format is used for each array element.
<b>Structure fields</b>	All elements with the same definition—the same field name and C declaration type—are affected by the display setting.

**Show As**

Displays a submenu that provides commands for changing the default type interpretation of variables. The commands on this submenu are mainly useful for assembler variables—data at assembler labels—because these are, by default, displayed as integers. For more information, see *Viewing assembler variables*, page 102.

**Save to File**

Saves content to a file in a tab-separated format.

**Right Align 'Value' Column**

Right-aligns the contents of the **Value** column.

**Options**

Displays the **IDE Options** dialog box where you can set various options for C-SPY windows.

## Live Watch window

The **Live Watch** window is available from the **View** menu.

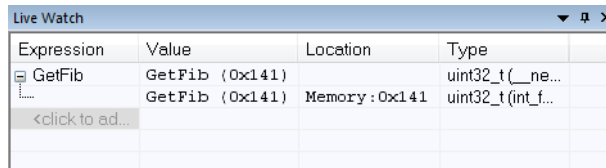

This window repeatedly samples and displays the value of expressions while your application is executing. Variables in the expressions must be statically located, such as global variables.

Live watch is available for these cores, with the following restrictions:

Core	Restrictions
Cortex-M	Live watch is fully supported for Cortex-M. Access to memory or setting breakpoints is always possible during execution.
Cortex-A/R	Live watch is only possible when you use the C-SPY I-jet driver or J-Link/J-Trace driver, and only when you use the option <code>--drv_mem_ap</code> , see <code>-drv_mem_ap</code> , page 543.
Armxxx-S	The support for live watch is limited for Armxxx-S cores, see below. Setting hardware breakpoints during execution is always possible for all supported C-SPY drivers.
Arm7/Arm9, including Armxxx-S, when you use the C-SPY J-Link/J-Trace driver	<p>Memory accesses must be made by your application. By adding a small program—a DCC handler—that communicates with the debugger through the DCC unit to your application, memory can be read/written during execution. Software breakpoints can also be set by the DCC handler.</p> <p>Just add the files <code>JLINKDCC_Process.c</code> and <code>JLINKDCC_HandleDataAbort.s</code> located in <code>arm\src\debugger\dcc</code> to your project and call the <code>JLINKDCC_Process</code> function regularly, for example every millisecond.</p> <p>In your local copy of the <code>cstartup</code> file, modify the interrupt vector table so that data aborts will call the <code>JLINKDCC_HandleDataAbort</code> handler. See also <code>-jlink_dcc_timeout</code>, page 556.</p>

Table 8: Live watch for the different devices

See also *Editing in C-SPY windows*, page 60.

## Requirements

This window is available for all combinations of C-SPY drivers and devices, except for the C-SPY Stellaris driver. However, note that the actual support for live watch is limited for all cores except Cortex-M, see the table above.

## Display area

This area contains these columns:

### Expression

The name of the variable.

A name in square brackets, for example `[fieldname]`, is either the name of a base class for a struct/class object or—if shown in gray and *italic*—a pointer to the full object when of a class type derived from the original class.

### Value

The value of the variable. Values that have changed are highlighted in red.

Dragging text or a variable from another window and dropping it on the **Value** column will assign a new value to the variable in that row.

This column is editable.

### Location

The location in memory where this variable is stored.

### Type

The data type of the variable.

## Context menu

This context menu is available:

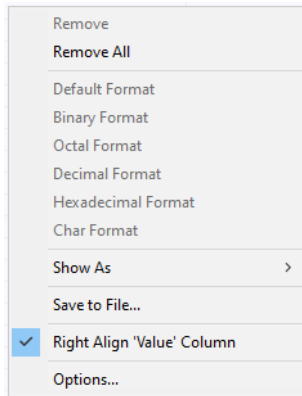

**Note:** The contents of this menu are dynamic and depend on which features that your combination of software and hardware supports. However, the list of menu commands below is complete and covers all possible commands.

These commands are available:

### Remove

Removes the selected expression from the window.

### Remove All

Removes all expressions listed in the window.

### Default Format

### Binary Format

### Octal Format

### Decimal Format

### Hexadecimal Format

### Char Format

Changes the display format of expressions. The display format setting affects different types of expressions in different ways. Your selection of display format is saved between debug sessions. These commands are available if a selected line in the window contains a variable.

The display format setting affects different types of expressions in these ways:

#### Variables

The display setting affects only the selected variable, not other variables.

**Array elements** The display setting affects the complete array, that is, the same display format is used for each array element.

**Structure fields** All elements with the same definition—the same field name and C declaration type—are affected by the display setting.

### Show As

Displays a submenu that provides commands for changing the default type interpretation of variables. The commands on this submenu are mainly useful for assembler variables—data at assembler labels—because these are, by default, displayed as integers. For more information, see *Viewing assembler variables*, page 102.

### Save to File

Saves content to a file in a tab-separated format.

### Right Align 'Value' Column

Right-aligns the contents of the **Value** column.

### Options

Displays the **IDE Options** dialog box where you can set various options for C-SPY windows.

## Statics window

The **Statics** window is available from the **View** menu.

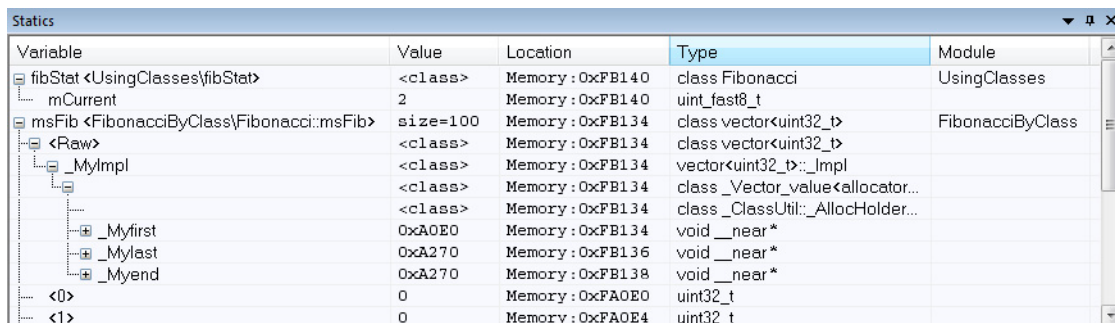

Variable	Value	Location	Type	Module
fibStat <UsingClasses\fibStat>	<class>	Memory : 0xFB140	class Fibonacci	UsingClasses
mCurrent	2	Memory : 0xFB140	uint_fast8_t	
msFib <FibonacciByClass\Fibonacci::msFib>	size=100	Memory : 0xFB134	class vector<uint32_t>	FibonacciByClass
<Raw>	<class>	Memory : 0xFB134	class vector<uint32_t>	
_MyImpl	<class>	Memory : 0xFB134	vector<uint32_t>::Impl	
	<class>	Memory : 0xFB134	class _Vector_value<allocator...	
	<class>	Memory : 0xFB134	class _ClassUtil::_AllocHolder...	
+ _Myfirst	0xA0E0	Memory : 0xFB134	void __near*	
+ _Mylast	0xA270	Memory : 0xFB136	void __near*	
+ _Myend	0xA270	Memory : 0xFB138	void __near*	
<0>	0	Memory : 0xFA0E0	uint32_t	
<1>	0	Memory : 0xFA0E4	uint32_t	

This window displays the values of variables with static storage duration that you have selected. Typically, that is variables with file scope but it can also be static variables in functions and classes. Note that `volatile` declared variables with static storage duration will not be displayed.

Every time execution in C-SPY stops, the values in the **Statics** window are recalculated. Values that have changed since the last stop are highlighted in red.

Click any column header (except for **Value**) to sort on that column.

See also *Editing in C-SPY windows*, page 60.

#### To select variables to monitor:

- 1 In the window, right-click and choose **Select Statics** from the context menu. The window now lists all variables with static storage duration.
- 2 Either individually select the variables you want to display, or choose one of the **Select** commands from the context menu.
- 3 When you have made your selections, choose **Select Statics** from the context menu to toggle back to normal display mode.

### Requirements

Can be used with all C-SPY debugger drivers and debug probes.

### Display area

This area contains these columns:

#### Variable

The name of the variable. The base name of the variable is followed by the full name, which includes module, class, or function scope. This column is not editable.

A name in square brackets, for example `[fieldname]`, is either the name of a base class for a struct/class object or—if shown in gray and *italic*—a pointer to the full object when of a class type derived from the original class.

#### Value

The value of the variable. Values that have changed are highlighted in red.

Dragging text or a variable from another window and dropping it on the **Value** column will assign a new value to the variable in that row.

This column is editable.

#### Location

The location in memory where this variable is stored.

#### Type

The data type of the variable.



**Module**

The module of the variable.

**Context menu**

This context menu is available:

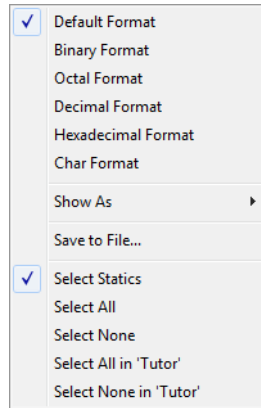

These commands are available:

**Default Format****Binary Format****Octal Format****Decimal Format****Hexadecimal Format****Char Format**

Changes the display format of expressions. The display format setting affects different types of expressions in different ways. Your selection of display format is saved between debug sessions. These commands are available if a selected line in the window contains a variable.

The display format setting affects different types of expressions in these ways:

<b>Variables</b>	The display setting affects only the selected variable, not other variables.
<b>Array elements</b>	The display setting affects the complete array, that is, the same display format is used for each array element.
<b>Structure fields</b>	All elements with the same definition—the same field name and C declaration type—are affected by the display setting.

**Show As**

Displays a submenu that provides commands for changing the default type interpretation of variables. The commands on this submenu are mainly useful for assembler variables—data at assembler labels—because these are, by default, displayed as integers. For more information, see *Viewing assembler variables*, page 102.

**Save to File**

Saves the content of the **Statics** window to a log file.

**Select Statics**

Selects all variables with static storage duration—this command also enables all **Select** commands below. Select the variables you want to monitor. When you have made your selections, select this menu command again to toggle back to normal display mode.

**Select All**

Selects all variables.

**Select None**

Deselects all variables.

**Select All in *module***

Selects all variables in the selected module.

**Select None in *module***

Deselects all variables in the selected module.

## Quick Watch window

The **Quick Watch** window is available from the **View** menu and from the context menu in the editor window.

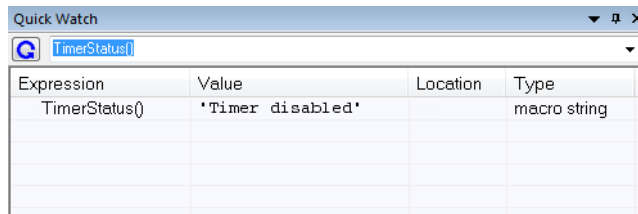

Use this window to watch the value of a variable or expression and evaluate expressions at a specific point in time.

In contrast to the **Watch** window, the **Quick Watch** window gives you precise control over when to evaluate the expression. For single variables this might not be necessary,

but for expressions with possible side effects, such as assignments and C-SPY macro functions, it allows you to perform evaluations under controlled conditions.

See also *Editing in C-SPY windows*, page 60.

### To evaluate an expression:

**1** In the editor window, right-click on the expression you want to examine and choose **Quick Watch** from the context menu that appears.

**2** The expression will automatically appear in the **Quick Watch** window.

Alternatively:

**3** In the **Quick Watch** window, type the expression you want to examine in the **Expressions** text box.



**4** Click the **Recalculate** button to calculate the value of the expression.

For an example, see *Using C-SPY macros*, page 429.

### Requirements

Can be used with all C-SPY debugger drivers and debug probes.

### Display area

This area contains these columns:

#### Expression

The name of the variable.

A name in square brackets, for example `[fieldname]`, is either the name of a base class for a struct/class object or—if shown in gray and *italic*—a pointer to the full object when of a class type derived from the original class.

#### Value

The value of the variable. Values that have changed are highlighted in red.

Dragging text or a variable from another window and dropping it on the **Value** column will assign a new value to the variable in that row.

This column is editable.

#### Location

The location in memory where this variable is stored.

#### Type

The data type of the variable.

## Context menu

This context menu is available:

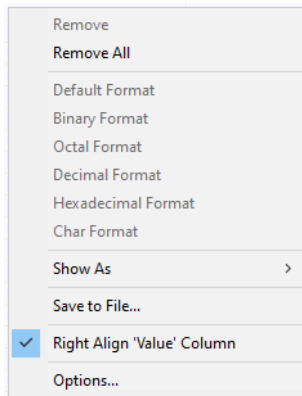

**Note:** The contents of this menu are dynamic and depend on which features that your combination of software and hardware supports. However, the list of menu commands below is complete and covers all possible commands.

These commands are available:

### Remove

Removes the selected expression from the window.

### Remove All

Removes all expressions listed in the window.

### Default Format

### Binary Format

### Octal Format

### Decimal Format

### Hexadecimal Format

### Char Format

Changes the display format of expressions. The display format setting affects different types of expressions in different ways. Your selection of display format is saved between debug sessions. These commands are available if a selected line in the window contains a variable.

The display format setting affects different types of expressions in these ways:

#### Variables

The display setting affects only the selected variable, not other variables.

**Array elements** The display setting affects the complete array, that is, the same display format is used for each array element.

**Structure fields** All elements with the same definition—the same field name and C declaration type—are affected by the display setting.

### Show As

Displays a submenu that provides commands for changing the default type interpretation of variables. The commands on this submenu are mainly useful for assembler variables—data at assembler labels—because these are, by default, displayed as integers. For more information, see *Viewing assembler variables*, page 102.

### Save to File

Saves content to a file in a tab-separated format.

### Right Align ‘Value’ Column

Right-aligns the contents of the **Value** column.

### Options

Displays the **IDE Options** dialog box where you can set various options for C-SPY windows.

## Symbols window

The **Symbols** window is available from the **View** menu.

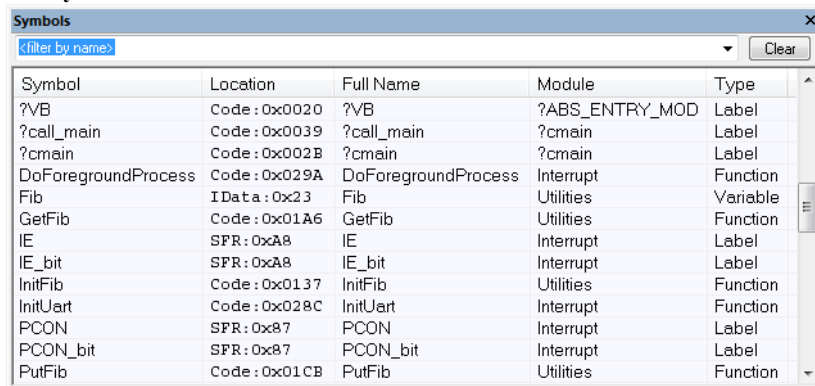

Symbol	Location	Full Name	Module	Type
?VB	Code : 0x0020	?VB	?ABS_ENTRY_MOD	Label
?call_main	Code : 0x0039	?call_main	?cmain	Label
?cmain	Code : 0x002B	?cmain	?cmain	Label
DoForegroundProcess	Code : 0x029A	DoForegroundProcess	Interrupt	Function
Fib	IData : 0x23	Fib	Utilities	Variable
GetFib	Code : 0x01A6	GetFib	Utilities	Function
IE	SFR : 0xA8	IE	Interrupt	Label
IE_bit	SFR : 0xA8	IE_bit	Interrupt	Label
InitFib	Code : 0x0137	InitFib	Utilities	Function
InitUart	Code : 0x028C	InitUart	Interrupt	Function
PCON	SFR : 0x87	PCON	Interrupt	Label
PCON_bit	SFR : 0x87	PCON_bit	Interrupt	Label
PutFib	Code : 0x01CB	PutFib	Utilities	Function

This window displays all symbols with a static location, that is, C/C++ functions, assembler labels, and variables with static storage duration, including symbols from the runtime library.

You can drag the contents of cells in the **Symbol**, **Location**, and **Full Name** columns and drop in some other windows in the IDE.

## Requirements

Can be used with all C-SPY debugger drivers and debug probes.

## Toolbar

The toolbar contains:

### <filter by name>

Type the first characters of the symbol names that you want to find, and press Enter. All symbols (of the types you have selected on the context menu) whose name starts with these characters will be displayed. If you have chosen not to display some types of symbols, the window will list how many of those that were found but are not displayed.

Use the drop-down list to use old search strings. The search box has a history depth of eight search entries.

### Clear

Cancels the effects of the search filter and restores all symbols in the window.

## Display area

This area contains these columns:

### Symbol

The symbol name.

### Location

The memory address.

### Full name

The symbol name—often the same as the contents of the **Symbol** column but differs for example for C++ member functions.

### Module

The program module where the symbol is defined.

### Type

The symbol type, whether it is a function, label, or variable.

Click the column headers to sort the list by symbol name, location, full name, module, or type.

## Context menu

This context menu is available:

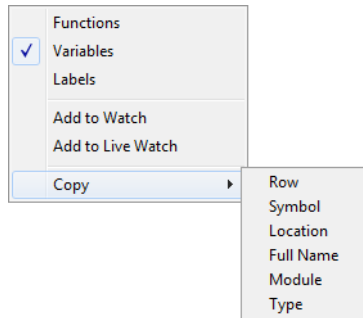

These commands are available:

### Functions

Toggles the display of function symbols on or off in the list.

### Variables

Toggles the display of variables on or off in the list.

### Labels

Toggles the display of labels on or off in the list.

### Add to Watch

Adds the selected symbol to the **Watch** window.

### Add to Live Watch

Adds the selected symbol to the **Live Watch** window.

### Copy

Copies the contents of the cells on the selected line.

**Row** Copies all contents of the selected line.

**Symbol** Copies the contents of the **Symbol** cell on the selected line.

**Location** Copies the contents of the **Location** cell on the selected line.

**Full Name** Copies the contents of the **Full Name** cell on the selected line.

**Module** Copies the contents of the **Module** cell on the selected line.

**Type** Copies the contents of the **Type** cell on the selected line.

## Resolve Symbol Ambiguity dialog box

The **Resolve Symbol Ambiguity** dialog box appears, for example, when you specify a symbol in the **Disassembly** window to go to, and there are several instances of the same symbol due to templates or function overloading.

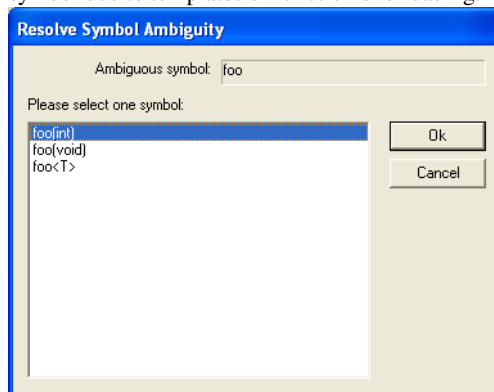

### Requirements

Can be used with all C-SPY debugger drivers and debug probes.

### Ambiguous symbol

Indicates which symbol that is ambiguous.

### Please select one symbol

A list of possible matches for the ambiguous symbol. Select the one you want to use.



# Breakpoints

- Introduction to setting and using breakpoints
- Setting breakpoints
- Reference information on breakpoints

---

## Introduction to setting and using breakpoints

These topics are covered:

- Reasons for using breakpoints
- Briefly about setting breakpoints
- Breakpoint types
- Breakpoint icons
- Breakpoints in the C-SPY simulator
- Breakpoints in the C-SPY hardware debugger drivers
- Breakpoint consumers
- Breakpoint options

### REASONS FOR USING BREAKPOINTS

C-SPY® lets you set various types of breakpoints in the application you are debugging, allowing you to stop at locations of particular interest. You can set a breakpoint at a *code* location to investigate whether your program logic is correct, or to get trace printouts. In addition to code breakpoints, and depending on what C-SPY driver you are using, additional breakpoint types might be available. For example, you might be able to set a *data* breakpoint, to investigate how and when the data changes.

You can let the execution stop under certain *conditions*, which you specify. You can also let the breakpoint trigger a *side effect*, for instance executing a C-SPY macro function, by transparently stopping the execution and then resuming. The macro function can be defined to perform a wide variety of actions, for instance, simulating hardware behavior.

All these possibilities provide you with a flexible tool for investigating the status of your application.

## BRIEFLY ABOUT SETTING BREAKPOINTS

You can set breakpoints in many various ways, allowing for different levels of interaction, precision, timing, and automation. All the breakpoints you define will appear in the **Breakpoints** window. From this window you can conveniently view all breakpoints, enable and disable breakpoints, and open a dialog box for defining new breakpoints. The **Breakpoint Usage** window also lists all internally used breakpoints, see *Breakpoint consumers*, page 130.

Breakpoints are set with a higher precision than single lines, using the same mechanism as when stepping. For more information about the precision, see *Single stepping*, page 76.

You can set breakpoints while you edit your code even if no debug session is active. The breakpoints will then be validated when the debug session starts. Breakpoints are preserved between debug sessions.

**Note:** For most hardware debugger systems it is only possible to set breakpoints when the application is not executing.

## BREAKPOINT TYPES

Depending on the C-SPY driver you are using, C-SPY supports different types of breakpoints.

### Code breakpoints

Code breakpoints are used for code locations to investigate whether your program logic is correct or to get trace printouts. Code breakpoints are triggered when an instruction is fetched from the specified location. If you have set the breakpoint on a specific machine instruction, the breakpoint will be triggered and the execution will stop, before the instruction is executed.

### Log breakpoints

Log breakpoints provide a convenient way to add trace printouts without having to add any code to your application source code. Log breakpoints are triggered when an instruction is fetched from the specified location. If you have set the breakpoint on a specific machine instruction, the breakpoint will be triggered and the execution will temporarily stop and print the specified message in the C-SPY **Debug Log** window.

### Trace Start/Stop Trigger breakpoints

Trace Start Trigger and Trace Stop Trigger breakpoints start and stop trace data collection—a convenient way to analyze instructions between two execution points.

## Data breakpoints

Data breakpoints are primarily useful for variables that have a fixed address in memory. If you set a breakpoint on an accessible local variable, the breakpoint is set on the corresponding memory location. The validity of this location is only guaranteed for small parts of the code. Data breakpoints are triggered when data is accessed at the specified location.

The execution will usually stop directly after the instruction that accessed the data has been executed. However, on some newer Arm devices like Cortex-M55, data breakpoints might not stop the execution until several instructions later. Moreover, if the CPU is halted for any reason, any such “delayed” data breakpoint will never have any effect. Examples: If two consecutive instructions read from two different locations that both have a data breakpoint, the second one will not have any effect. Likewise, if a data breakpoint is immediately followed by a code breakpoint, then that data breakpoint will not have any effect.

## Data Log breakpoints

Data log breakpoints are triggered when a specified variable is accessed. A log entry is written in the **SWO Trace** window (**Trace** window in the simulator) for each access. A log message can also be displayed in the **Data Log** window. Data logs can also be displayed on the Data Log graph in the **Timeline** window, if that window is enabled. However, these log messages require that you have set up trace data in the **SWO Configuration** dialog box, see *SWO Configuration dialog box*, page 225.

You can set data log breakpoints using the **Breakpoints** window, the **Memory** window, and the editor window.

Using a single instruction, the microcontroller can only access values that are four bytes or less. If you specify a data log breakpoint on a memory location that cannot be accessed by one instruction, for example a `double` or a too large area in the **Memory** window, the result might not be what you intended.

## Immediate breakpoints

For some cores and devices, the C-SPY simulator lets you set *immediate* breakpoints, which will halt instruction execution only temporarily. This allows a C-SPY macro function to be called when the simulated processor is about to read data from a location or immediately after it has written data. Instruction execution will resume after the action.

This type of breakpoint is useful for simulating memory-mapped devices of various kinds (for instance serial ports and timers). When the simulated processor reads from a memory-mapped location, a C-SPY macro function can intervene and supply

appropriate data. Conversely, when the simulated processor writes to a memory-mapped location, a C-SPY macro function can act on the value that was written.

### JTAG watchpoints

The C-SPY J-Link/J-Trace driver can take advantage of the JTAG watchpoint mechanism in Arm7/9 cores.

The watchpoints are implemented using the functionality provided by the Arm EmbeddedICE™ macrocell. The macrocell is part of every Arm core that supports the JTAG interface. The EmbeddedICE watchpoint comparator compares the address bus, data bus, CPU control signals and external input signals with the defined watchpoint in real time. When all defined conditions are true, the program will break.

The watchpoints are implicitly used by C-SPY to set code breakpoints or data breakpoints in the application. When setting breakpoints in read/write memory, only one watchpoint is needed by the debugger. When setting breakpoints in read-only memory, one watchpoint is needed for each breakpoint. Because the macrocell only implements two hardware watchpoints, the maximum number of breakpoints in read-only memory is two.

For a more detailed description of the Arm JTAG watchpoint mechanism, refer to these documents from Arm Limited:

- *ARM7TDMI (rev 3) Technical Reference Manual: Chapter 5, Debug Interface, and Appendix B, Debug in Depth*
- *Application Note 28, The ARM7TDMI Debug Architecture*

### Flash breakpoints

Software code breakpoints (breakpoints that rely on writing breakpoint instructions into memory) can be set in flash memory or other non-volatile executable memory using the flash breakpoint mechanism. This involves programming of the flash memory using a flash loader in the same way as is done when downloading an application.

This breakpoint type is only available for the C-SPY I-jet driver.

## BREAKPOINT ICONS

A breakpoint is marked with an icon in the left margin of the editor window, and the icon varies with the type of breakpoint:

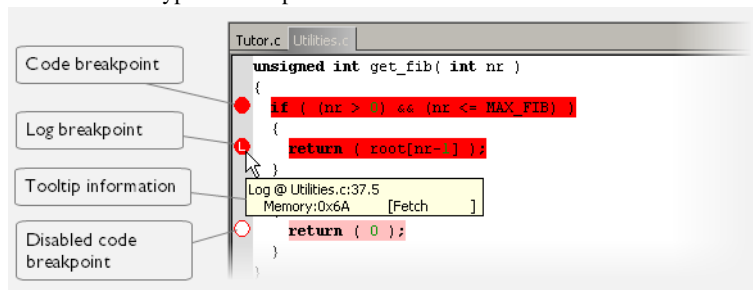

If the breakpoint icon does not appear, make sure the option **Show bookmarks** is selected, see Editor options in the *IDE Project Management and Building Guide for Arm*.



Just point at the breakpoint icon with the mouse pointer to get detailed tooltip information about all breakpoints set on the same location. The first row gives user breakpoint information, the following rows describe the physical breakpoints used for implementing the user breakpoint. The latter information can also be seen in the **Breakpoint Usage** window.

**Note:** The breakpoint icons might look different for the C-SPY driver you are using.

## BREAKPOINTS IN THE C-SPY SIMULATOR

For some cores and devices, the C-SPY simulator supports all breakpoint types. The C-SPY simulator always supports code, data, and log breakpoints for all cores and devices. The number of breakpoints is unlimited.

## BREAKPOINTS IN THE C-SPY HARDWARE DEBUGGER DRIVERS

Using the C-SPY drivers for hardware debugger systems you can set various breakpoint types. The amount of breakpoints you can set depends on the number of *hardware breakpoints* available on the target system or whether you have enabled *software breakpoints*, in which case the number of breakpoints you can set is unlimited.

When software breakpoints are enabled, the debugger will first use any available hardware breakpoints before using software breakpoints. Exceeding the number of available hardware breakpoints, when software breakpoints are not enabled, causes the debugger to single step. This will significantly reduce the execution speed. For this reason you must be aware of the different breakpoint consumers.

For information about the characteristics of breakpoints for the different target systems, see the manufacturer's documentation.

## BREAKPOINT CONSUMERS

A debugger system includes several consumers of breakpoints.

### User breakpoints

The breakpoints you define in the breakpoint dialog box or by toggling breakpoints in the editor window often consume one physical breakpoint each, but this can vary greatly. Some user breakpoints consume several physical breakpoints and conversely, several user breakpoints can share one physical breakpoint. User breakpoints are displayed in the same way both in the **Breakpoint Usage** window and in the **Breakpoints** window, for example **Data @[R] callCount**.

### C-SPY itself

C-SPY itself also consumes breakpoints. C-SPY will set a breakpoint if:

- The debugger option **Run to** has been selected, and any step command is used. These are temporary breakpoints which are only set during a debug session. This means that they are not visible in the **Breakpoints** window.
- The linker option **Semihosted** or **IAR breakpoint** has been selected. In the DLIB runtime environment, C-SPY will set a system breakpoint on the `__DebugBreak` label.

These types of breakpoint consumers are displayed in the **Breakpoint Usage** window, for example, **C-SPY Terminal I/O & libsupport module**.

### C-SPY plugin modules

For example, modules for real-time operating systems can consume additional breakpoints. Specifically, by default, the **Stack** window consumes one physical breakpoint.

#### To disable the breakpoint used by the Stack window:

- 1 Choose **Tools>Options>Stack**.
- 2 Deselect the **Stack pointer(s) not valid until program reaches: label** option.

To disable the **Stack** window entirely, choose **Tools>Options>Stack** and make sure all options are deselected.

## BREAKPOINT OPTIONS

For the following C-SPY drivers it is possible to set some driver-specific breakpoint options before you start C-SPY:

- GDB Server
- I-jet
- J-Link/J-Trace
- CMSIS-DAP
- ST-LINK
- TI XDS

For more information, see *Breakpoints options*, page 154.

---

## Setting breakpoints

These tasks are covered:

- Various ways to set a breakpoint
- Toggling a simple code breakpoint
- Setting breakpoints using the dialog box
- Setting a data breakpoint in the Memory window
- Setting breakpoints using system macros
- Setting a breakpoint on an exception vector
- Setting breakpoints in `__ramfunc` declared functions
- Useful breakpoint hints

## VARIOUS WAYS TO SET A BREAKPOINT

You can set a breakpoint in various ways:

- Toggling a simple code breakpoint.
- Using the **New Breakpoints** dialog box and the **Edit Breakpoints** dialog box available from the context menus in the editor window, **Breakpoints** window, and in the **Disassembly** window. The dialog boxes give you access to all breakpoint options.
- Setting a data breakpoint on a memory area directly in the **Memory** window.
- Using predefined system macros for setting breakpoints, which allows automation.

The different methods offer different levels of simplicity, complexity, and automation.

## TOGGLING A SIMPLE CODE BREAKPOINT

Toggling a code breakpoint is a quick method of setting a breakpoint. The following methods are available both in the editor window and in the **Disassembly** window:



- Click in the gray left-side margin of the window
- Place the insertion point in the C source statement or assembler instruction where you want the breakpoint, and click the **Toggle Breakpoint** button in the toolbar
- Choose **Edit>Toggle Breakpoint**
- Right-click and choose **Toggle Breakpoint** from the context menu.

## SETTING BREAKPOINTS USING THE DIALOG BOX

The advantage of using a breakpoint dialog box is that it provides you with a graphical interface where you can interactively fine-tune the characteristics of the breakpoints. You can set the options and quickly test whether the breakpoint works according to your intentions.

All breakpoints you define using a breakpoint dialog box are preserved between debug sessions.

You can open the dialog box from the context menu available in the editor window, **Breakpoints** window, and in the **Disassembly** window.

### To set a new breakpoint:

- 1 Choose **View>Breakpoints** to open the **Breakpoints** window.
- 2 In the **Breakpoints** window, right-click, and choose **New Breakpoint** from the context menu.
- 3 On the submenu, choose the breakpoint type you want to set. Depending on the C-SPY driver you are using, different breakpoint types are available.
- 4 In the breakpoint dialog box that appears, specify the breakpoint settings and click **OK**.  
The breakpoint is displayed in the **Breakpoints** window.

### To modify an existing breakpoint:

- 1 In the **Breakpoints** window, editor window, or in the **Disassembly** window, select the breakpoint you want to modify and right-click to open the context menu.



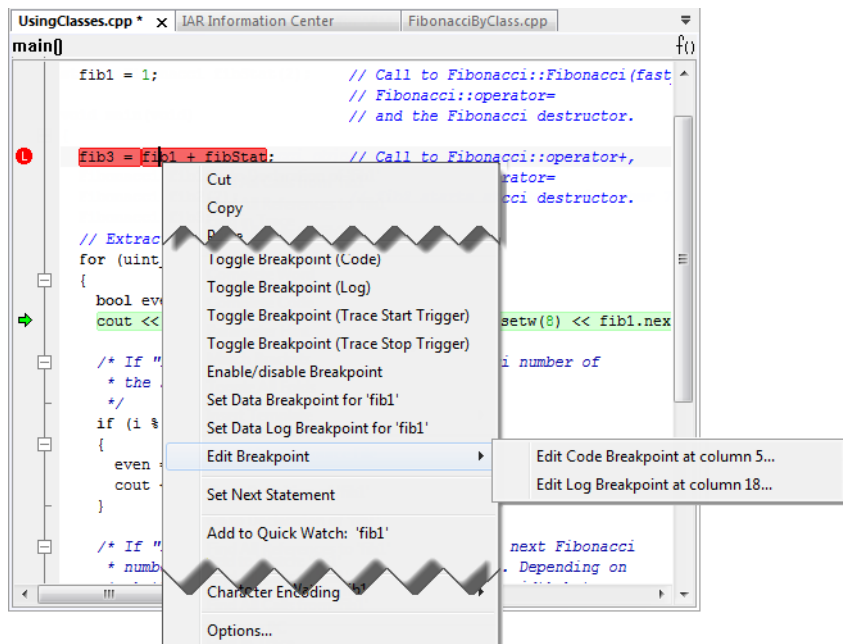

If there are several breakpoints on the same source code line, the breakpoints will be listed on a submenu.

- 2 On the context menu, choose the appropriate command.
- 3 In the breakpoint dialog box that appears, specify the breakpoint settings and click **OK**.

The breakpoint is displayed in the **Breakpoints** window.

## SETTING A DATA BREAKPOINT IN THE MEMORY WINDOW

You can set breakpoints directly on a memory location in the **Memory** window. Right-click in the window and choose the breakpoint command from the context menu that appears. To set the breakpoint on a range, select a portion of the memory contents.

The breakpoint is not highlighted in the **Memory** window—instead, you can see, edit, and remove it using the **Breakpoints** window, which is available from the **View** menu. The breakpoints you set in the **Memory** window will be triggered for both read and write accesses. All breakpoints defined in this window are preserved between debug sessions.

**Note:** Setting breakpoints directly in the **Memory** window is only possible if the driver you use supports this.

## SETTING BREAKPOINTS USING SYSTEM MACROS

You can set breakpoints, not only in the breakpoint dialog box, but also by using built-in C-SPY system macros. When you use system macros for setting breakpoints, the breakpoint characteristics are specified as macro parameters.

Macros are useful when you have already specified your breakpoints so that they fully meet your requirements. You can define your breakpoints in a macro file, using built-in system macros, and execute the file at C-SPY startup. The breakpoints will then be set automatically each time you start C-SPY. Another advantage is that the debug session will be documented, and that several engineers involved in the development project can share the macro files.

**Note:** If you use system macros for setting breakpoints, you can still view and modify them in the **Breakpoints** window. In contrast to using the dialog box for defining breakpoints, all breakpoints that are defined using system macros are removed when you exit the debug session.

C-SPY macro for breakpoints	Simulator	I-jet	J-Link/J-Trace	CMSIS-DAP	CADI	E2
__setCodeBreak	Yes	Yes	Yes	Yes	Yes	Yes
__setDataBreak	Yes	Yes	—	Yes	—	—
__setLogBreak	Yes	Yes	Yes	Yes	—	Yes
__setDataLogBreak	Yes <sup>1</sup>	Yes	—	—	—	—
__setSimBreak	Yes <sup>1</sup>	—	—	—	—	—
__setTraceStartBreak	Yes <sup>1</sup>	Yes	—	—	—	—
__setTraceStopBreak	Yes <sup>1</sup>	Yes	—	—	—	—
__clearBreak	Yes <sup>1</sup>	Yes	Yes	Yes	Yes	Yes

Table 9: C-SPY macros for breakpoints

1. Not for all cores and devices.

C-SPY macro for breakpoints	GDB Server	ST-LINK and TI MSP-FET	PE micro	TI Stellaris / TI XDS	Nu-Link	G+Link
__setCodeBreak	Yes	Yes	Yes	Yes	Yes	Yes
__setDataBreak	—	—	—	—	—	Yes
__setLogBreak	Yes	Yes	Yes	Yes	Yes	Yes

Table 10: C-SPY macros for breakpoints

C-SPY macro for breakpoints	GDB Server	ST-LINKand TI MSP-FET	PE micro	TI		
				Stellaris / TI XDS	Nu-Link	G+Link
__setDataLogBreak	—	—	—	—	—	—
__setSimBreak	—	—	—	—	—	—
__setTraceStartBreak	—	—	—	—	—	—
__setTraceStopBreak	—	—	—	—	—	—
__clearBreak	Yes	Yes	Yes	Yes	Yes	Yes

Table 10: C-SPY macros for breakpoints (Continued)

For information about each breakpoint macro, see *Reference information on C-SPY system macros*, page 444.

### Setting breakpoints at C-SPY startup using a setup macro file

You can use a setup macro file to define breakpoints at C-SPY startup. Follow the procedure described in *Using C-SPY macros*, page 429.

### SETTING A BREAKPOINT ON AN EXCEPTION VECTOR

You can set breakpoints on exception vectors for ARM9, Cortex-R4, and Cortex-M3 devices. Use the **Vector Catch** dialog box to set a breakpoint directly on a vector in the interrupt vector table, without using a hardware breakpoint. For more information, see *Vector Catch dialog box*, page 157.

For the C-SPY I-jet driver and the C-SPY J-Link/J-Trace driver, it is also possible to set breakpoints directly on a vector already in the options dialog box, see *J-Link/J-Trace — Setup*, page 611.

This procedure applies to the C-SPY I-jet driver and the C-SPY J-Link/J-Trace driver.

#### To set a breakpoint on an exception vector:

- 1 Select the correct device. Before starting C-SPY, choose **Project>Options** and select the **General Options** category. Choose the appropriate core or device from one of the **Processor variant** drop-down lists available on the **Target** page.
- 2 Start C-SPY.
- 3 Choose *C-SPY driver>Vector Catch*. By default, vectors are selected according to your settings on the Breakpoints options page, see *Breakpoints options*, page 154.
- 4 In the **Vector Catch** dialog box, select the vector you want to set a breakpoint on, and click **OK**. The breakpoint will only be triggered at the beginning of the exception.

## SETTING BREAKPOINTS IN \_\_RAMFUNC DECLARED FUNCTIONS

To set a breakpoint in a `__ramfunc` declared function, the program execution must have reached the `main` function. The system startup code moves all `__ramfunc` declared functions from their stored location—normally flash memory—to their RAM location, which means the `__ramfunc` declared functions are not in their proper place and breakpoints cannot be set until you have executed up to the `main` function. Use the **Restore software breakpoints** option to solve this problem, see *Breakpoints options*, page 154, specifically the **Restore software breakpoints** option.

In addition, breakpoints in `__ramfunc` declared functions added from the editor have to be disabled prior to invoking C-SPY and prior to exiting a debug session.

For information about the `__ramfunc` keyword, see the *IAR C/C++ Development Guide for Arm*.

## USEFUL BREAKPOINT HINTS

Below are some useful hints related to setting breakpoints.



### Tracing incorrect function arguments

If a function with a pointer argument is sometimes incorrectly called with a `NULL` argument, you might want to debug that behavior. These methods can be useful:

- Set a breakpoint on the first line of the function with a condition that is true only when the parameter is 0. The breakpoint will then not be triggered until the problematic situation actually occurs. The advantage of this method is that no extra source code is needed. The drawback is that the execution speed might become unacceptably low.
- You can use the `assert` macro in your problematic function, for example:

```
int MyFunction(int * MyPtr)
{
    assert(MyPtr != 0); /* Assert macro added to your source
                        code. */
    /* Here comes the rest of your function. */
}
```

The execution will break whenever the condition is true. The advantage is that the execution speed is only slightly affected, but the drawback is that you will get a small extra footprint in your source code. In addition, the only way to get rid of the execution stop is to remove the macro and rebuild your source code.

- Instead of using the `assert` macro, you can modify your function like this:

```
int MyFunction(int * MyPtr)
{
    if(MyPtr == 0)
        MyDummyStatement; /* Dummy statement where you set a
                           breakpoint. */
    /* Here comes the rest of your function. */
}
```

You must also set a breakpoint on the extra dummy statement, so that the execution will break whenever the condition is true. The advantage is that the execution speed is only very slightly affected, but the drawback is that you will still get a small extra footprint in your source code. However, in this way you can get rid of the execution stop by just removing the breakpoint.



### Performing a task and continuing execution

You can perform a task when a breakpoint is triggered and then automatically continue execution.

You can use the **Action** text box to associate an action with the breakpoint, for instance a C-SPY macro function. When the breakpoint is triggered and the execution of your application has stopped, the macro function will be executed. In this case, the execution will not continue automatically.

Instead, you can set a condition which returns 0 (false). When the breakpoint is triggered, the condition—which can be a call to a C-SPY macro that performs a task—is evaluated and because it is not true, execution continues.

Consider this example where the C-SPY macro function performs a simple task:

```
__var my_counter;

count()
{
    my_counter += 1;
    return 0;
}
```

To use this function as a condition for the breakpoint, type `count()` in the **Expression** text box under **Conditions**. The task will then be performed when the breakpoint is triggered. Because the macro function `count` returns 0, the condition is false and the execution of the program will resume automatically, without any stop.

## Reference information on breakpoints

Reference information about:

- *Breakpoints window*, page 138
- *Breakpoint Usage window*, page 140
- *Code breakpoints dialog box*, page 141
- *JTAG Watchpoints dialog box*, page 143
- *Log breakpoints dialog box*, page 146
- *Data breakpoints dialog box*, page 147
- *Data Log breakpoints dialog box*, page 151
- *Data Log breakpoints dialog box (C-SPY hardware drivers)*, page 152
- *Breakpoints options*, page 154
- *Immediate breakpoints dialog box*, page 156
- *Vector Catch dialog box*, page 157
- *Flash breakpoints dialog box*, page 158
- *Enter Location dialog box*, page 159
- *Resolve Source Ambiguity dialog box*, page 161

See also:

- *Reference information on C-SPY system macros*, page 444
- *Reference information on trace*, page 218

## Breakpoints window

The **Breakpoints** window is available from the **View** menu.

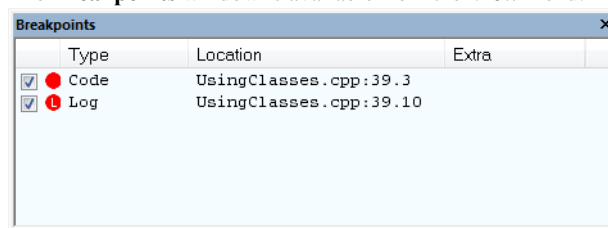

This window lists all breakpoints you define.

Use this window to conveniently monitor, enable, and disable breakpoints—you can also define new breakpoints and modify existing breakpoints.

**Requirements**

Can be used with all C-SPY debugger drivers and debug probes.

**Display area**

This area lists all breakpoints you define. For each breakpoint, information about the breakpoint type, source file, source line, and source column is provided.

**Context menu**

This context menu is available:

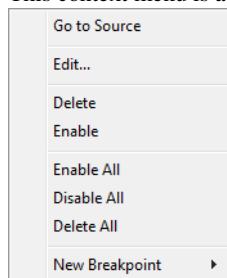

These commands are available:

**Go to Source**

Moves the insertion point to the location of the breakpoint, if the breakpoint has a source location. Double-click a breakpoint in the **Breakpoints** window to perform the same command.

**Edit**

Opens the breakpoint dialog box for the breakpoint you selected.

**Delete**

Deletes the breakpoint. Press the Delete key to perform the same command.

**Enable**

Enables the breakpoint. The check box at the beginning of the line will be selected. You can also perform the command by manually selecting the check box. This command is only available if the breakpoint is disabled.

**Disable**

Disables the breakpoint. The check box at the beginning of the line will be deselected. You can also perform this command by manually deselecting the check box. This command is only available if the breakpoint is enabled.

**Enable All**

Enables all defined breakpoints.

**Disable All**

Disables all defined breakpoints.

**Delete All**

Deletes all defined breakpoints.

**New Breakpoint**

Displays a submenu where you can open the breakpoint dialog box for the available breakpoint types. All breakpoints you define using this dialog box are preserved between debug sessions.

**Breakpoint Usage window**

The **Breakpoint Usage** window is available from the menu specific to the C-SPY driver you are using.

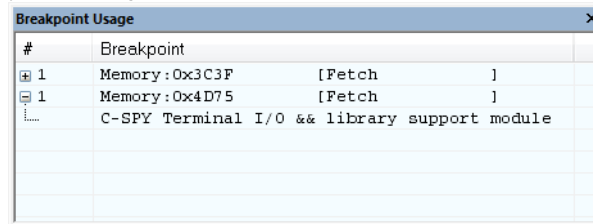

#	Breakpoint	
1	Memory : 0x3C3F	[Fetch ]
1	Memory : 0x4D75	[Fetch ]
...	C-SPY Terminal I/O && library support module	

This window lists all breakpoints currently set in the target system, both the ones you have defined and the ones used internally by C-SPY. The format of the items in this window depends on the C-SPY driver you are using.

The window gives a low-level view of all breakpoints, related but not identical to the list of breakpoints displayed in the **Breakpoints** window.

C-SPY uses breakpoints when stepping. Use the **Breakpoint Usage** window for:

- Identifying all breakpoint consumers
- Checking that the number of active breakpoints is supported by the target system
- Configuring the debugger to use the available breakpoints in a better way, if possible.

For more information, see *Breakpoints in the C-SPY hardware debugger drivers*, page 129.

**Requirements**

Can be used with all C-SPY debugger drivers and debug probes.



## Display area

For each breakpoint in the list, the address and access type are displayed. Each breakpoint in the list can also be expanded to show its originator.

## Code breakpoints dialog box

The **Code** breakpoints dialog box is available from the context menu in the editor window, **Breakpoints** window, and in the **Disassembly** window.

This figure reflects the C-SPY simulator.

Use the **Code** breakpoints dialog box to set a code breakpoint, see *Setting breakpoints using the dialog box*, page 132.

## Requirements

Can be used with all C-SPY debugger drivers and debug probes.

## Break At

Specify the code location of the breakpoint in the text box. Alternatively, click the **Edit** button to open the **Enter Location** dialog box, see *Enter Location dialog box*, page 159.

## Breakpoint type

Overrides the default breakpoint type. Select the **Override default** check box and choose between the **Software** and **Hardware** options.

You can specify the breakpoint type for these C-SPY drivers:

- The C-SPY I-jet driver
- The C-SPY CMSIS-DAP driver

- The C-SPY GDB Server driver
- The C-SPY J-Link/J-Trace driver
- The C-SPY TI MSP-FET driver
- The C-SPY TI XDS driver

### Size

Determines whether there should be a size—in practice, a range—of locations where the breakpoint will trigger. Each fetch access to the specified memory range will trigger the breakpoint. Select how to specify the size:

#### Auto

The size will be set automatically, typically to 1.

#### Manual

Specify the size of the breakpoint range in the text box.

**Note:** This option might not be supported by the combination of C-SPY driver and device that you are using.

### Action

Specify a valid C-SPY expression, which is evaluated when the breakpoint is triggered and the condition is true. For more information, see *Useful breakpoint hints*, page 136.

### Conditions

Specify simple or complex conditions:

#### Expression

Specify a valid C-SPY expression, see *C-SPY expressions*, page 98.

#### Condition true

The breakpoint is triggered if the value of the expression is true.

#### Condition changed

The breakpoint is triggered if the value of the expression has changed since it was last evaluated.

#### Skip count

The number of times that the breakpoint condition must be fulfilled before the breakpoint starts triggering. After that, the breakpoint will trigger every time the condition is fulfilled.

## JTAG Watchpoints dialog box

The JTAG Watchpoints dialog box is available from the driver-specific menu.

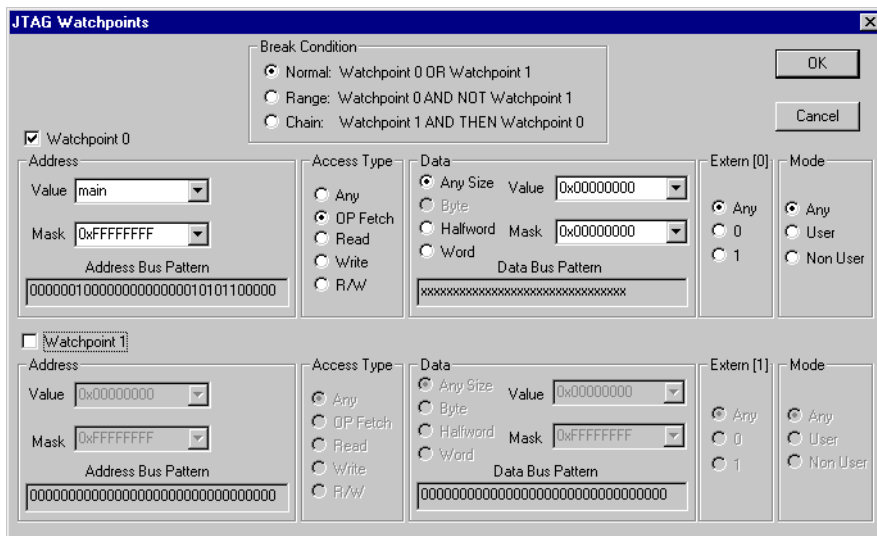

Use this dialog box to directly control the two hardware watchpoint units. If the number of needed watchpoints (including implicit watchpoints used by the breakpoint system) exceeds two, an error message will be displayed when you click the **OK** button. This check is also performed for the C-SPY **Go** button.

### To cause a trigger for accesses in the range 0x20-0xFF:

- 1 Set **Break Condition** to **Range**.
- 2 Set the address value of watchpoint 0 to 0 and the mask to 0xFF.
- 3 Set the address value of watchpoint 1 to 0 and the mask to 0x1F.

### Requirements

The J-Link/J-Trace driver and a supported device.

### Break Condition

Selects how the defined watchpoints will be used. Choose between:

**Normal** Uses the two watchpoints individually (OR).

<b>Range</b>	Combines both watchpoints to cover a range where watchpoint 0 defines the start of the range and watchpoint 1 the end of the range. Selectable ranges are restricted to being powers of 2.
<b>Chain</b>	Makes a trigger of watchpoint 1 and watchpoint 0. A program break will then occur when watchpoint 0 is triggered.

**Address**

Specify the address to watch for.

<b>Value</b>	Specify an address or a C-SPY expression that evaluates to an address. Alternatively, you can select an address you have previously watched for from the drop-down list. For detailed information about C-SPY expressions, see <i>C-SPY expressions</i> , page 98.
<b>Mask</b>	Qualifies each bit in the value. A zero bit in the mask will cause the corresponding bit in the value to be ignored in the comparison. To match any address, enter 0. Note that the mask values are inverted with respect to the notation used in the Arm hardware manuals.
<b>Address Bus Pattern</b>	Shows the bit pattern to be used by the address comparator. Ignored bits as specified in the mask are shown as x.

**Access Type**

Selects the access type of the data to watch for:

<b>Any</b>	Matches any access type.
<b>OP Fetch</b>	Matches an operation code (instruction) fetch.
<b>Read</b>	Reads from location.
<b>Write</b>	Writes to location.
<b>R/W</b>	Reads from or writes to location.

**Data**

Specifies the data to watch for. For size, choose between:

<b>Any Size</b>	Matches data accesses of any size.
<b>Byte</b>	Matches byte size accesses.
<b>Halfword</b>	Matches halfword size accesses.
<b>Word</b>	Matches word size accesses.

You can specify a value to watch for. Choose between:

<b>Value</b>	Specify a value or a C-SPY expression. Alternatively, you can select a value you have previously watched for from the drop-down list. For detailed information about C-SPY expressions, see <i>C-SPY expressions</i> , page 98.
<b>Mask</b>	Qualifies each bit in the value. A zero bit in the mask will cause the corresponding bit in the value to be ignored in the comparison. To match any address, enter 0. Note that the mask values are inverted with respect to the notation used in the Arm hardware manuals.
<b>Data Bus Pattern</b>	Shows the bit pattern to be used by the address comparator. Ignored bits as specified in the mask are shown as x.

**Extern**

Defines the state of the external input. Choose between:

<b>Any</b>	Ignores the state.
<b>0</b>	Defines the state as low.
<b>1</b>	Defines the state as high.

**Mode**

Selects which CPU mode that must be active for a match. Choose between:

<b>User</b>	Selects the CPU mode USER.
<b>Non User</b>	Selects one of the CPU modes SYSTEM SVC, UND, ABORT, IRQ, or FIQ.
<b>Any</b>	Ignores the CPU mode.

## Log breakpoints dialog box

The **Log** breakpoints dialog box is available from the context menu in the editor window, **Breakpoints** window, and in the **Disassembly** window.

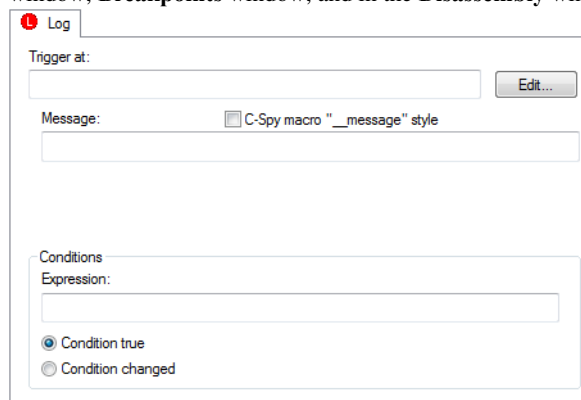

This figure reflects the C-SPY simulator.

Use the **Log** breakpoints dialog box to set a log breakpoint, see *Setting breakpoints using the dialog box*, page 132.

### Requirements

Can be used with all C-SPY debugger drivers and debug probes.

### Trigger at

Specify the code location of the breakpoint. Alternatively, click the **Edit** button to open the **Enter Location** dialog box, see *Enter Location dialog box*, page 159.

### Message

Specify the message you want to be displayed in the C-SPY **Debug Log** window. The message can either be plain text, or—if you also select the option **C-SPY macro " \_\_message" style**—a comma-separated list of arguments.

### C-SPY macro " \_\_message" style

Select this option to make a comma-separated list of arguments specified in the **Message** text box be treated exactly as the arguments to the C-SPY macro language statement `__message`, see *Formatted output*, page 438.

## Conditions

Specify simple or complex conditions:

### Expression

Specify a valid C-SPY expression, see *C-SPY expressions*, page 98.

### Condition true

The breakpoint is triggered if the value of the expression is true.

### Condition changed

The breakpoint is triggered if the value of the expression has changed since it was last evaluated.

## Data breakpoints dialog box

The **Data** breakpoints dialog box is available from the context menu in the editor window, **Breakpoints** window, the **Memory** window, and in the **Disassembly** window.

This figure reflects the C-SPY simulator.

Use the **Data** breakpoints dialog box to set a data breakpoint, see *Setting breakpoints using the dialog box*, page 132. Data breakpoints never stop execution within a single instruction. They are recorded and reported after the instruction is executed.

## Requirements

One of these alternatives:

- The C-SPY simulator
- The C-SPY CMSIS-DAP driver
- The C-SPY GDB Server driver

- The C-SPY G+LINK driver
- The C-SPY I-jet driver
- The C-SPY J-Link/J-Trace driver
- The C-SPY ST-LINK driver
- The C-SPY TI MSP-FET driver
- The C-SPY TI Stellaris driver
- The C-SPY TI XDS driver and a Cortex-M device

### **Break At**

Specify the data location of the breakpoint in the text box. Alternatively, click the **Edit** button to open the **Enter Location** dialog box, see *Enter Location dialog box*, page 159.

### **Access Type**

Selects the type of memory access that triggers the breakpoint:

#### **Read/Write**

Reads from or writes to location.

#### **Read**

Reads from location.

#### **Write**

Writes to location.

### **Size**

Determines whether there should be a size—in practice, a range—of locations where the breakpoint will trigger. Each fetch access to the specified memory range will trigger the breakpoint. Select how to specify the size:

#### **Auto**

The size will automatically be based on the type of expression the breakpoint is set on. For example, if you set the breakpoint on a 12-byte structure, the size of the breakpoint will be 12 bytes.

#### **Manual**

Specify the size of the breakpoint range in the text box.



For data breakpoints, this can be useful if you want the breakpoint to be triggered on accesses to data structures, such as arrays, structs, and unions.

### Action

Specify a valid C-SPY expression, which is evaluated when the breakpoint is triggered and the condition is true. For more information, see *Useful breakpoint hints*, page 136.

### Conditions

Specify simple or complex conditions:

#### Expression

Specify a valid C-SPY expression, see *C-SPY expressions*, page 98.

#### Condition true

The breakpoint is triggered if the value of the expression is true.

#### Condition changed

The breakpoint is triggered if the value of the expression has changed since it was last evaluated.

#### Skip count

The number of times that the breakpoint condition must be fulfilled before the breakpoint starts triggering. After that, the breakpoint will trigger every time the condition is fulfilled.

### Trigger range

Shows the requested range and the effective range to be covered by the trace. The range suggested is either within or exactly the area specified by the **Break At** and the **Size** options.

#### Extend to cover requested range

Extends the breakpoint so that a whole data structure is covered. For data structures that do not fit the size of the possible breakpoint ranges supplied by the hardware breakpoint unit, for example three bytes, the breakpoint range will not cover the whole data structure. Note that the breakpoint range will be extended beyond the size of the data structure, which might cause false triggers at adjacent data.

The **Trigger range** option is available for all C-SPY hardware drivers that support data breakpoints.

**Match data**

Enables matching of the accessed data. Use the **Match data** options in combination with the access types for data. This option can be useful when you want a trigger when a variable has a certain value.

**Value**

Specify a data value.

**Mask**

Specify which part of the value to match (word, halfword, or byte).

For Cortex-M, the data mask is limited to one of these exact values:

0xFFFFFFFF, which means that the complete word must match.

0xFFFF, which means that the match can be either the upper or lower 16-bit part of a word or halfword.

0xFF, which means that the match can be either the upper, middle, or lower 8-bit part of a word, halfword, or byte. For example, for the data 0xVV, any 32-bit access matching a xxxxxxVV, xxxVVxx, xVVxxxx, or VVxxxxxx pattern, and any 16-bit access matching xxVV or VVxx, and an 8-bit access with exact match triggers the breakpoint.

The **Match data** options are only available for I-jet, I-jet Trace, J-Link/J-Trace and ST-LINK, and when using an Arm7/9 or a Cortex-M device.

**Note:** For Cortex-M devices, only one breakpoint with Match data can be set. Such a breakpoint uses two hardware breakpoints.

**Note:** The **Match Data** options are not available for Cortex-M0, Cortex-M1, or Cortex-M0+, and they are not available for ARMv8 devices.

## Data Log breakpoints dialog box

The **Data Log** breakpoints dialog box is available from the context menu in the **Breakpoints** window.



This figure reflects the C-SPY simulator.

Use the **Data Log** breakpoints dialog box to set a maximum of four data log breakpoints on memory addresses, see *Setting breakpoints using the dialog box*, page 132.

See also *Data Log breakpoints*, page 127 and *Getting started using data logging*, page 262.

### Requirements

The C-SPY simulator.

### Break At

Specify a memory location as a variable (with static storage duration) or as an address.

### Access Type

Selects the type of access to the variable that generates a log entry:

#### Read/Write

Read and write accesses from or writes to location of the variable.

#### Read

Read accesses from the location of the variable.

#### Write

Write accesses to location of the variable.

## Data Log breakpoints dialog box (C-SPY hardware drivers)

The **Data Log** breakpoints dialog box is available from the context menu in the editor window, **Breakpoints** window, the **Memory** window, and in the **Disassembly** window.

Use the **Data Log** breakpoints dialog box to set a maximum of four data log breakpoints. You can set a data log breakpoint on 8, 16, and 32-bit variables.

See also *Data Log breakpoints*, page 127 and *Getting started using data logging*, page 262.

### Requirements

A device and a debug probe with support for SWO.

### Trigger at

Specify the data location of the breakpoint. Alternatively, click the **Edit** button to open the **Enter Location** dialog box, see *Enter Location dialog box*, page 159.

### Access Type

Selects the type of memory access that triggers the breakpoint:

#### Read/Write

Reads from or writes to location.

#### Read

Reads from location; except for Cortex-M3, revision 1 devices.

#### Write

Writes to location; except for Cortex-M3, revision 1 devices.

**Size**

Determines whether there should be a size—in practice, a range—of locations where the breakpoint will trigger. Each fetch access to the specified memory range will trigger the breakpoint. Select how to specify the size:

**Auto**

The size will automatically be based on the type of expression the breakpoint is set on. For example, if you set the breakpoint on a 12-byte structure, the size of the breakpoint will be 12 bytes.

**Manual**

Specify the size of the breakpoint range in the text box.

**Trigger range**

Shows the requested range and the effective range to be covered by the trace. The range suggested is either within or exactly the area specified by the **Trigger at** and the **Size** options.

**Extend to cover requested range**

Extends the breakpoint so that a whole data structure is covered. For data structures that do not fit the size of the possible breakpoint ranges supplied by the hardware breakpoint unit, for example three bytes, the breakpoint range will not cover the whole data structure. Note that the breakpoint range will be extended beyond the size of the data structure, which might cause false triggers at adjacent data.

## Breakpoints options

The **Breakpoints** options page is available in the **Options** dialog box. Choose **Project>Options**, select the category specific to the debugger system you are using, and click the **Breakpoints** tab.

Use this dialog box to set driver-specific breakpoint options.

### Requirements

One of these alternatives:

- The C-SPY CMSIS-DAP driver
- The C-SPY GDB Server driver
- The C-SPY I-jet driver
- The C-SPY J-Link/J-Trace driver
- The C-SPY ST-LINK driver
- The C-SPY TI XDS driver

### Default breakpoint type

Selects the type of breakpoint resource to be used when setting a breakpoint. Choose between:

<b>Auto</b>	Uses a software breakpoint. If this is not possible, a hardware breakpoint will be used. The debugger will use read/write sequences to test for RAM; in that case, a software breakpoint will be used. The Auto option works for most applications. However, there are cases when the performed read/write sequence will make the flash memory malfunction. In that case, use the <b>Hardware</b> option.
<b>Hardware</b>	Uses hardware breakpoints. If it is not possible, no breakpoint will be set.
<b>Software</b>	Uses software breakpoints. If it is not possible, no breakpoint will be set.

### Restore software breakpoints at

Restores software breakpoints that were overwritten during system startup.

This can be useful if you have an application that is copied to RAM during startup and is then executing in RAM. This can, for example, be the case if you use the `initialize by copy` linker directive for code in the linker configuration file or if you have any `__ramfunc` declared functions in your application.

In this case, all breakpoints will be destroyed during the RAM copying when the C-SPY debugger starts. By using the **Restore software breakpoints at** option, C-SPY will restore the destroyed breakpoints.

Use the text field to specify the location in your application at which point you want C-SPY to restore the breakpoints. The default location is the label `_call_main`.

### Catch exceptions

Sets a breakpoint directly on a vector in the interrupt vector table, without using a hardware breakpoint. This option is available for Arm9/10/11 and all Cortex devices. The settings you make will work as default settings for the project. However, you can override these default settings during the debug session by using the **Vector Catch** dialog box, see *Setting a breakpoint on an exception vector*, page 135.

The settings you make will be preserved during debug sessions.

This option is supported by the C-SPY I-jet driver and the C-SPY J-Link/J-Trace driver.

## Immediate breakpoints dialog box

The **Immediate** breakpoints dialog box is available from the context menu in the editor window, **Breakpoints** window, the **Memory** window, and in the **Disassembly** window.

In the C-SPY simulator, you can use the **Immediate** breakpoints dialog box to set an immediate breakpoint, see *Setting breakpoints using the dialog box*, page 132. Immediate breakpoints do not stop execution at all—they only suspend it temporarily.

**Note:** Immediate breakpoints are not available for all cores and devices.

### Requirements

The C-SPY simulator. Not available for all cores and devices.

### Trigger at

Specify the data location of the breakpoint. Alternatively, click the **Edit** button to open the **Enter Location** dialog box, see *Enter Location dialog box*, page 159.

### Access Type

Selects the type of memory access that triggers the breakpoint:

#### Read

Reads from location.

#### Write

Writes to location.

### Action

Specify a valid C-SPY expression, which is evaluated when the breakpoint is triggered and the condition is true. For more information, see *Useful breakpoint hints*, page 136.



## Vector Catch dialog box

The **Vector Catch** dialog box is available from the C-SPY driver menu.

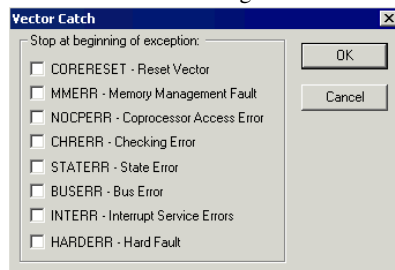

Use this dialog box to set a breakpoint directly on a vector in the interrupt vector table, without using a hardware breakpoint. You can set breakpoints on vectors for Arm9/10/11 and all Cortex devices.

Note that the settings you make here will not be preserved between debug sessions.

This figure reflects a Cortex-M device. If you are using another device, the contents of this dialog box might look different.

**Note:** For the C-SPY I-jet driver and the C-SPY J-Link/J-Trace driver, it is also possible to set breakpoints directly on a vector already in the options dialog box, see *J-Link/J-Trace — Setup*, page 611.

### Requirements

One of these alternatives:

- The C-SPY I-jet driver
- The C-SPY J-Link/J-Trace driver
- The C-SPY CMSIS-DAP driver

## Flash breakpoints dialog box

The **Flash** breakpoints dialog box is available from the context menu in the editor window, the **Breakpoints** window, the **Memory** window, and in the **Disassembly** window.

Use the **Flash** breakpoints dialog box to set a flash breakpoint.

### Requirements

The C-SPY I-jet driver.

### Break At

Specify the code location of the breakpoint in the text box. Alternatively, click the **Edit** button to open the **Enter Location** dialog box, see *Enter Location dialog box*, page 159.

### Action

Specify a valid C-SPY expression, which is evaluated when the breakpoint is triggered and the condition is true. For more information, see *Useful breakpoint hints*, page 136.

### Conditions

Specify simple or complex conditions:

#### Expression

Specify a valid C-SPY expression, see *C-SPY expressions*, page 98.

#### Condition true

The breakpoint is triggered if the value of the expression is true.

**Condition changed**

The breakpoint is triggered if the value of the expression has changed since it was last evaluated.

**Skip count**

The number of times that the breakpoint condition must be fulfilled before the breakpoint starts triggering. After that, the breakpoint will trigger every time the condition is fulfilled.

**Enter Location dialog box**

The **Enter Location** dialog box is available from the breakpoints dialog box, either when you set a new breakpoint or when you edit a breakpoint.

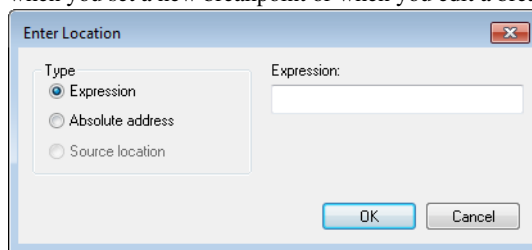

Use the **Enter Location** dialog box to specify the location of the breakpoint.

**Note:** This dialog box looks different depending on the **Type** you select.

**Type**

Selects the type of location to be used for the breakpoint, choose between:

**Expression**

A C-SPY expression, whose value evaluates to a valid code or data location.

A code location, for example the function `main`, is typically used for code breakpoints.

A data location is the name of a variable and is typically used for data breakpoints. For example, `my_var` refers to the location of the variable `my_var`, and `arr[3]` refers to the location of the fourth element of the array `arr`. For static variables declared with the same name in several functions, use the syntax `my_func::my_static_variable` to refer to a specific variable.

For more information about C-SPY expressions, see *C-SPY expressions*, page 98.

**Absolute address**

An absolute location on the form *zone:hexaddress* or simply *hexaddress* (for example `Memory:0x42`). *zone* refers to C-SPY memory zones and specifies in which memory the address belongs, see *C-SPY memory zones*, page 165.

**Source location**

A location in your C source code using the syntax:

*{filename}.row.column*.

*filename* specifies the filename and full path.

*row* specifies the row in which you want the breakpoint.

*column* specifies the column in which you want the breakpoint.

For example, `{C:\src\prog.c}.22.3` sets a breakpoint on the third character position on row 22 in the source file `prog.c`. Note that in quoted form, for example in a C-SPY macro, you must instead write

`{C:\\src\\prog.c}.22.3`.

Note that the Source location type is usually meaningful only for code locations in code breakpoints. Depending on the C-SPY driver you are using, **Source location** might not be available for data and immediate breakpoints.

## Resolve Source Ambiguity dialog box

The **Resolve Source Ambiguity** dialog box appears, for example, when you try to set a breakpoint on templates and the source location corresponds to more than one function.

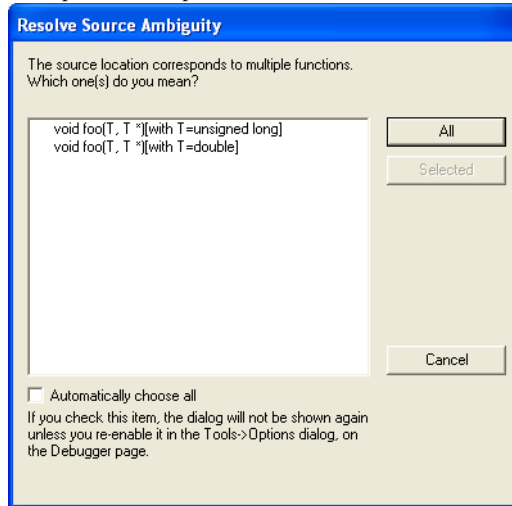

To resolve a source ambiguity, perform one of these actions:

- In the text box, select one or several of the listed locations and click **Selected**.
- Click **All**.

### All

The breakpoint will be set on all listed locations.

### Selected

The breakpoint will be set on the source locations that you have selected in the text box.

### Cancel

No location will be used.

### Automatically choose all

Determines that whenever a specified source location corresponds to more than one function, all locations will be used.

Note that this option can also be specified in the **IDE Options** dialog box, see Debugger options in the *IDE Project Management and Building Guide for Arm*.



# Memory and registers

- Introduction to monitoring memory and registers
- Monitoring memory and registers
- Reference information on memory and registers

---

## Introduction to monitoring memory and registers

These topics are covered:

- Briefly about monitoring memory and registers
- C-SPY memory zones
- Memory configuration for the C-SPY simulator
- Memory configuration for C-SPY hardware debugger drivers

### BRIEFLY ABOUT MONITORING MEMORY AND REGISTERS

C-SPY provides many windows for monitoring memory and registers, most of them available from the **View** menu:

- The **Memory** window  
Gives an up-to-date display of a specified area of memory—a memory zone—and allows you to edit it. *Data coverage* along with execution of your application is highlighted with different colors. You can fill specified areas with specific values and you can set breakpoints directly on a memory location or range. You can open several instances of this window, to monitor different memory areas. The content of the window can be regularly updated while your application is executing.
- The **Symbolic Memory** window  
Displays how variables with static storage duration are laid out in memory. This can be useful for better understanding memory usage or for investigating problems caused by variables being overwritten, for example by buffer overruns.
- The **Stack** window  
Displays the contents of the stack, including how stack variables are laid out in memory. In addition, integrity checks of the stack can be performed to detect and warn about problems with stack overflow. For example, the **Stack** window is useful for determining the optimal size of the stack. You can open up to two instances of this window, each showing different stacks or different display modes of the same stack.

- The **Registers** window

Gives an up-to-date display of the contents of the processor registers and SFRs, and allows you to edit them. Except for the hardwired group of CPU registers, additional registers are defined in the device description file. These registers are the device-specific memory-mapped control and status registers for the peripheral units on the Arm devices. Because of the large amount of registers—memory-mapped peripheral unit registers and CPU registers—it is inconvenient to show all registers concurrently in the **Registers** window. Instead you can divide registers into *application-specific groups*. You can choose to load either predefined register groups or define your own groups. You can open several instances of this window, each showing a different register group.

- The **SFR Setup** window

Displays the currently defined SFRs that C-SPY has information about, both factory-defined (retrieved from the device description file) and custom-defined SFRs. If required, you can use the **Edit SFR** dialog box to customize the SFR definitions.

To view the memory contents for a specific variable, simply drag the variable to the **Memory** window or the **Symbolic Memory** window. The memory area where the variable is located will appear.



Reading the value of some registers might influence the runtime behavior of your application. For example, reading the value of a UART status register might reset a pending bit, which leads to the lack of an interrupt that would have processed a received byte. To prevent this from happening, make sure that the **Registers** window containing any such registers is closed when debugging a running application.



## C-SPY MEMORY ZONES

In C-SPY, the term *zone* is used for a named memory area. A memory address, or *location*, is a combination of a zone and a numerical offset into that zone. The Arm architecture has only one zone, `Memory`, which covers the whole Arm memory range.

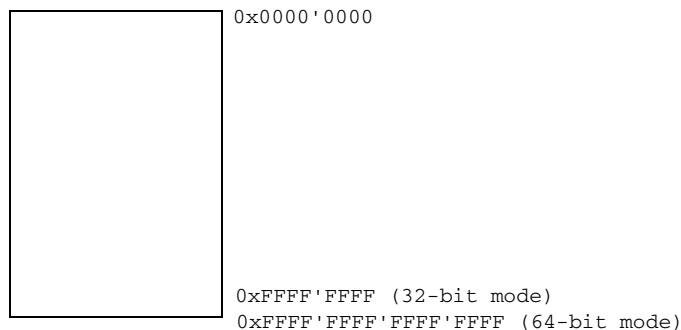

Default zone `Memory`

Memory zones are used in several contexts, most importantly in the **Memory** and **Disassembly** windows, and in C-SPY macros. In the windows, use the **Zone** box to choose which memory zone to display.

For normal memory, the default zone `Memory` can be used, but certain I/O registers might require to be accessed as 8, 16, 32, or 64 bits to give correct results. By using different memory zones, you can control the access width used for reading and writing in, for example, the **Memory** window. When using the zone `Memory`, the debugger automatically selects the most suitable access width.

**Note:** For the C-SPY I-jet driver, you can specify the automatic selection of access width in the **Edit Memory Range** dialog box, see *Edit Memory Range dialog box for C-SPY hardware debugger drivers*, page 203.

## MEMORY CONFIGURATION FOR THE C-SPY SIMULATOR

To simulate the target system properly, the C-SPY simulator needs information about the memory configuration. By default, C-SPY uses a configuration based on information retrieved from the device description file.

The C-SPY simulator provides various mechanisms to improve the configuration further:

- If the default memory configuration does not specify the required memory address ranges, you can specify the memory address ranges shall be based on:
  - The zones predefined in the device description file
  - The section information available in the debug file

- Or, you can define your own memory address ranges, which you typically might want to do if the files do not specify memory ranges for the *specific* device that you are using, but instead for a *family* of devices (perhaps with various amounts of on-chip RAM).
- For each memory address range, you can specify an *access type*. If a memory access occurs that does not agree with the specified access type, C-SPY will regard this as an illegal access and warn about it. In addition, an access to memory that is not defined is regarded as an illegal access. The purpose of memory access checking is to help you to identify memory access violations.

For more information, see *Memory Configuration dialog box for the C-SPY simulator*, page 196.

## MEMORY CONFIGURATION FOR C-SPY HARDWARE DEBUGGER DRIVERS

To handle memory as efficiently as possible during debugging, C-SPY needs information about the memory configuration. By default, C-SPY uses a configuration based on information retrieved from the device description file.

You should make sure the memory address ranges match the memory available on your device. Providing C-SPY with information about the memory layout of the target system is helpful in terms of both performance and functionality:

- Reading (and writing) memory (if your debug probe is connected through a USB port) can be fast, but is usually the limiting factor when C-SPY needs to update many debugger windows. C-SPY can cache memory contents to speed up performance, provided it has correct information about the target memory.
- You can inform C-SPY that the content of certain memory address ranges will not be changed during a debug session. C-SPY can keep a copy of that memory readable even when the target system does not normally allow reading (such as when it is executing).

Note that if you specify the cache type **ROM/Flash**, C-SPY treats such memory as constant during the whole debug session (which improves efficiency, when updating some C-SPY windows). If your application modifies flash memory during runtime, do not use the **ROM/Flash** cache type.

- You can prevent C-SPY from accessing memory outside specified memory address ranges, which can be important for certain hardware.

The **Memory Configuration** dialog box is automatically displayed the first time you start the C-SPY driver for a given project, unless the device description file contains a memory description which is explicitly tagged as correct and complete. Subsequent starts will not display the dialog box unless you have made project changes that might

cause the memory configuration to change, for example if you have selected another device description file.

For more information, see *Memory Configuration dialog box for C-SPY hardware debugger drivers*, page 200.

## Monitoring memory and registers

These tasks are covered:

- Defining application-specific register groups
- Monitoring stack usage

### DEFINING APPLICATION-SPECIFIC REGISTER GROUPS

Defining application-specific register groups minimizes the amount of registers displayed in the **Registers** windows and makes the debugging easier.

**To define application-specific register groups:**

- 1 Choose **View>Registers>Register User Groups Setup** during a debug session.

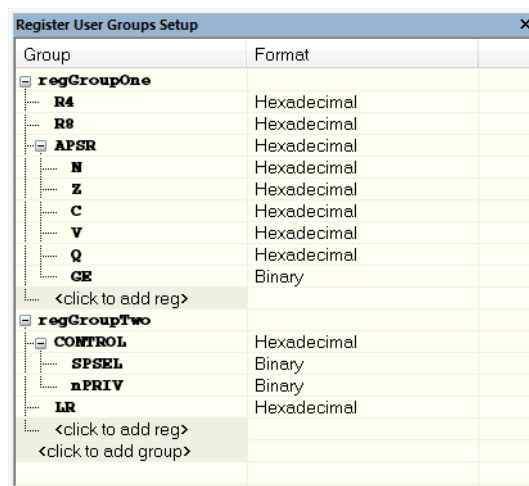

Right-clicking in the window displays a context menu with commands. For information about these commands, see *Register User Groups Setup window*, page 189.

- 2 Click on <click to add group> and specify the name of your group, for example **My Timer Group** and press Enter.

- 3 Underneath the group name, click on <click to add reg> and type the name of a register, and press Enter. You can also drag a register name from another window in the IDE. Repeat this for all registers that you want to add to your group.
- 4 As an optional step, right-click any registers for which you want to change the integer base, and choose **Format** from the context menu to select a suitable base.
- 5 When you are done, your new group is now available in the **Registers** windows.

If you want to define more application-specific groups, repeat this procedure for each group you want to define.

**Note:** If a certain SFR that you need cannot be added to a group, you can register your own SFRs. For more information, see *SFR Setup window*, page 191.

## MONITORING STACK USAGE

These are the two main use cases for the **Stack** window:

- Monitoring stack memory usage
- Monitoring the stack memory content.

In both cases, C-SPY retrieves information about the defined stack size and its allocation from the definition in the linker configuration file of the section holding the stack. If you, for some reason, have modified the stack initialization in the system startup code, `cstartup`, you should also change the section definition in the linker configuration file accordingly, otherwise the **Stack** window cannot track the stack usage. For more information, see the *IAR C/C++ Development Guide for Arm*.

### To monitor stack memory usage:

- I Before you start C-SPY, choose **Tools>Options**. On the **Stack** page:
  - Select **Enable graphical stack display and stack usage tracking**. This option also enables the option **Warn when exceeding stack threshold**. Specify a suitable threshold value.
  - Note also the option **Warn when stack pointer is out of bounds**. Any such warnings are displayed in the **Debug Log** window.

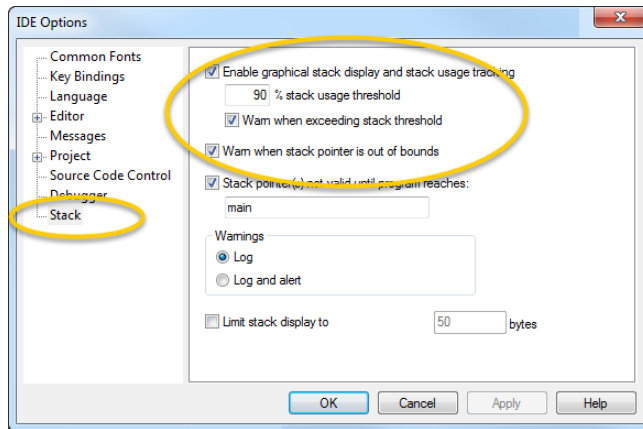

## 2 Start C-SPY.

When your application is first loaded, and upon each reset, the memory for the stack area is filled with the dedicated byte value `0xCD` before the application starts executing.

## 3 Choose **View>Stack>Stack 1** to open the **Stack** window.

Note that you can open up to two **Stack** windows, each showing a different stack—if several stacks are available—or the same stack with different display settings.

## 4 Start executing your application.

Whenever execution stops, the stack memory is searched from the end of the stack until a byte whose value is not `0xCD` is found, which is assumed to be how far the stack has been used. The light gray area of the stack bar represents the *unused* stack memory area, whereas the dark gray area of the bar represents the *used* stack memory.

For this example, you can see that only 44% of the reserved memory address range was used, which means that it could be worth considering decreasing the size of memory:

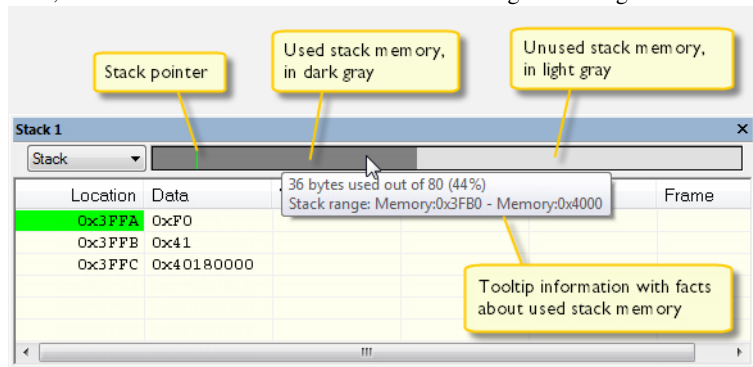

**Note:** Although this is a reasonably reliable way to track stack usage, there is no guarantee that a stack overflow is detected. For example, a stack *can* incorrectly grow outside its bounds, and even modify memory outside the stack area, without actually modifying any of the bytes near the end of the stack range. Likewise, your application might modify memory within the stack area by mistake.

#### To monitor the stack memory content:

- 1 Before you start monitoring stack memory, you might want to disable the option **Enable graphical stack display and stack usage tracking** to improve performance during debugging.
- 2 Start C-SPY.
- 3 Choose **View>Stack>Stack 1** to open the **Stack** window.

Note that you can access various context menus in the display area from where you can change display format, etc.

- 4 Start executing your application.

Whenever execution stops, you can monitor the stack memory, for example to see function parameters that are passed on the stack:

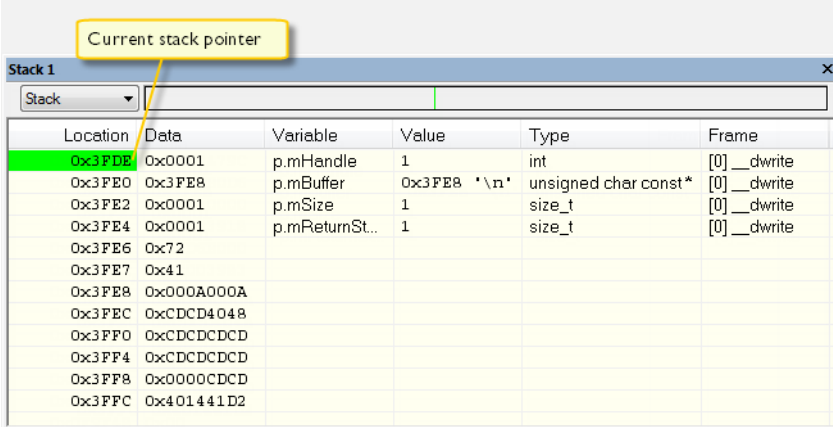

Location	Data	Variable	Value	Type	Frame
0x3FDE	0x0001	p.mHandle	1	int	[0] __dwrite
0x3FEO	0x3FE8	p.mBuffer	0x3FE8 '\n'	unsigned char const*	[0] __dwrite
0x3FE2	0x0001	p.mSize	1	size_t	[0] __dwrite
0x3FE4	0x0001	p.mReturnSt...	1	size_t	[0] __dwrite
0x3FE6	0x72				
0x3FE7	0x41				
0x3FE8	0x000A000A				
0x3FEC	0xCDCD4048				
0x3FF0	0xCDCDCDCD				
0x3FF4	0xCDCDCDCD				
0x3FF8	0x0000CDCD				
0x3FFC	0x401441D2				

## Reference information on memory and registers

Reference information about:

- *Memory window*, page 172
- *Memory Save dialog box*, page 176
- *Memory Restore dialog box*, page 177
- *Fill dialog box*, page 178
- *Symbolic Memory window*, page 179
- *Stack window*, page 182
- *Registers window*, page 186
- *Register User Groups Setup window*, page 189
- *SFR Setup window*, page 191
- *Edit SFR dialog box*, page 194
- *Memory Configuration dialog box for the C-SPY simulator*, page 196
- *Edit Memory Range dialog box for the C-SPY simulator*, page 198
- *Memory Configuration dialog box for C-SPY hardware debugger drivers*, page 200
- *Edit Memory Range dialog box for C-SPY hardware debugger drivers*, page 203

## Memory window

The **Memory** window is available from the **View** menu.

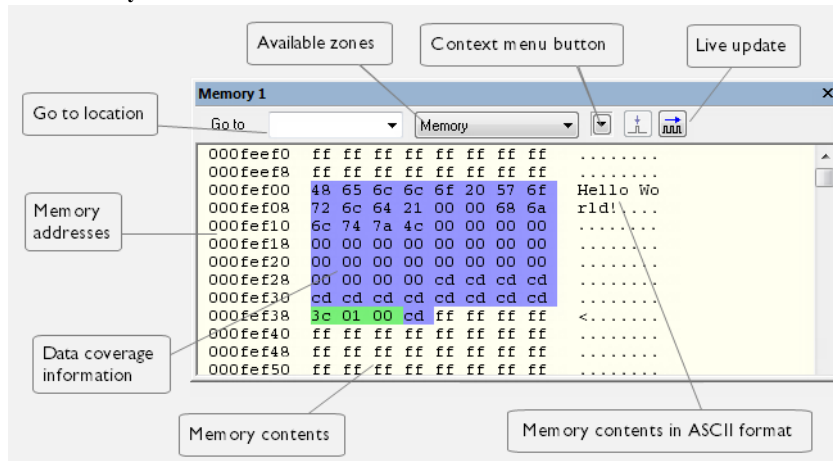

This window gives an up-to-date display of a specified area of memory—a memory zone—and allows you to edit it. You can open several instances of this window, which is very convenient if you want to keep track of several memory or register zones, or monitor different parts of the memory.



To view the memory corresponding to a variable, you can select it in the editor window and drag it to the **Memory** window.

See also *Editing in C-SPY windows*, page 60.

### Requirements

Can be used with all C-SPY debugger drivers and debug probes.

### Toolbar

The toolbar contains:

#### Go to

The memory location or symbol you want to view.

#### Zone

Selects a memory zone, see *C-SPY memory zones*, page 165.

#### Context menu button

Displays the context menu.



**Update Now**

Updates the content of the **Memory** window while your application is executing. This button is only enabled if the C-SPY driver you are using has access to the target system memory while your application is executing.

**Live Update**

Updates the contents of the **Memory** window regularly while your application is executing. This button is only enabled if the C-SPY driver you are using has access to the target system memory while your application is executing. To set the update frequency, specify an appropriate frequency in the **IDE Options>Debugger** dialog box.

**Display area**

The display area shows the addresses currently being viewed, the memory contents in the format you have chosen, and—provided that the display mode is set to **1x Units**—the memory contents in ASCII format. You can edit the contents of the display area, both in the hexadecimal part and the ASCII part of the area.

Data coverage is displayed with these colors:

Yellow	Indicates data that has been read.
Blue	Indicates data that has been written
Green	Indicates data that has been both read and written.

**Note:** Data coverage is not supported by all C-SPY drivers. Data coverage is supported by the C-SPY simulator for many cores and devices.

## Context menu

This context menu is available:

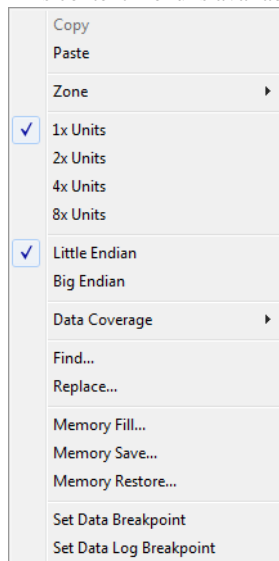

These commands are available:

### Copy

### Paste

Standard editing commands.

### Zone

Selects a memory zone, see *C-SPY memory zones*, page 165.

### 1x Units

Displays the memory contents as single bytes.

### 2x Units

Displays the memory contents as 2-byte groups.

### 4x Units

Displays the memory contents as 4-byte groups.

### 8x Units

Displays the memory contents as 8-byte groups.

### Little Endian

Displays the contents in little-endian byte order.

**Big Endian**

Displays the contents in big-endian byte order.

**Data Coverage**

Choose between:

**Enable** toggles data coverage on or off.

**Show** toggles between showing or hiding data coverage.

**Clear** clears all data coverage information.

These commands are only available if your C-SPY driver supports data coverage.

**Find**

Displays a dialog box where you can search for text within the **Memory** window—read about the **Find** dialog box in the *IDE Project Management and Building Guide for Arm*.

**Replace**

Displays a dialog box where you can search for a specified string and replace each occurrence with another string—read about the **Replace** dialog box in the *IDE Project Management and Building Guide for Arm*.

**Memory Fill**

Displays a dialog box, where you can fill a specified area with a value, see *Fill dialog box*, page 178.

**Memory Save**

Displays a dialog box, where you can save the contents of a specified memory area to a file, see *Memory Save dialog box*, page 176.

**Memory Restore**

Displays a dialog box, where you can load the contents of a file in Intel-hex or Motorola s-record format to a specified memory zone, see *Memory Restore dialog box*, page 177.

**Set Data Breakpoint**

Sets breakpoints directly in the **Memory** window. The breakpoint is not highlighted—you can see, edit, and remove it in the breakpoint dialog box. The breakpoints you set in this window will be triggered for both read and write access. For more information, see *Setting a data breakpoint in the Memory window*, page 133.

### Set Data Log Breakpoint

Sets a breakpoint on the start address of a memory selection directly in the **Memory** window. The breakpoint is not highlighted—you can see, edit, and remove it in the breakpoint dialog box. The breakpoints you set in this window will be triggered by both read and write accesses—to change this, use the **Breakpoints** window. For more information, see *Data Log breakpoints*, page 127 and *Getting started using data logging*, page 262.

## Memory Save dialog box

The **Memory Save** dialog box is available by choosing **Debug>Memory>Save** or from the context menu in the **Memory** window.

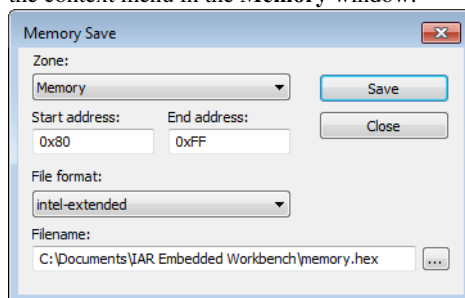

Use this dialog box to save the contents of a specified memory area to a file.

### Requirements

Can be used with all C-SPY debugger drivers and debug probes.

### Zone

Selects a memory zone, see *C-SPY memory zones*, page 165.

### Start address

Specify the start address of the memory range to be saved.

### End address

Specify the end address of the memory range to be saved.

### File format

Selects the file format to be used, which is Intel-extended by default.

**Filename**

Specify the destination file to be used. A browse button is available.

**Save**

Saves the selected range of the memory zone to the specified file.

**Memory Restore dialog box**

The **Memory Restore** dialog box is available by choosing **Debug>Memory>Restore** or from the context menu in the **Memory** window.

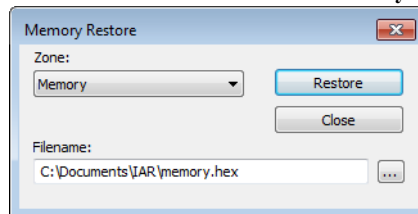

Use this dialog box to load the contents of a file in Intel-extended or Motorola S-record format to a specified memory zone.

**Requirements**

Can be used with all C-SPY debugger drivers and debug probes.

**Zone**

Selects a memory zone, see *C-SPY memory zones*, page 165.

**Filename**

Specify the file to be read. A browse button is available.

**Restore**

Loads the contents of the specified file to the selected memory zone.

## Fill dialog box

The **Fill** dialog box is available from the context menu in the **Memory** window.

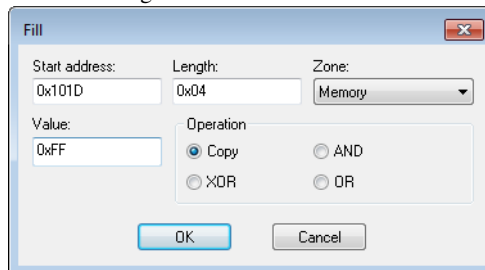

Use this dialog box to fill a specified area of memory with a value.

### Requirements

Can be used with all C-SPY debugger drivers and debug probes.

### Start address

Type the start address—in binary, octal, decimal, or hexadecimal notation.

### Length

Type the length—in binary, octal, decimal, or hexadecimal notation.

### Zone

Selects a memory zone, see *C-SPY memory zones*, page 165.

### Value

Type the 8-bit value to be used for filling each memory location.

### Operation

These are the available memory fill operations:

#### Copy

Value will be copied to the specified memory area.

#### AND

An **AND** operation will be performed between Value and the existing contents of memory before writing the result to memory.

#### XOR

An **XOR** operation will be performed between Value and the existing contents of memory before writing the result to memory.

**OR**

An OR operation will be performed between Value and the existing contents of memory before writing the result to memory.

## Symbolic Memory window

The **Symbolic Memory** window is available from the **View** menu during a debug session.

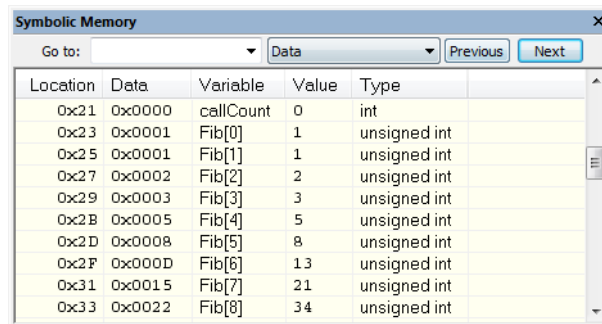

Location	Data	Variable	Value	Type
0x21	0x0000	callCount	0	int
0x23	0x0001	Fib[0]	1	unsigned int
0x25	0x0001	Fib[1]	1	unsigned int
0x27	0x0002	Fib[2]	2	unsigned int
0x29	0x0003	Fib[3]	3	unsigned int
0x2B	0x0005	Fib[4]	5	unsigned int
0x2D	0x0008	Fib[5]	8	unsigned int
0x2F	0x000D	Fib[6]	13	unsigned int
0x31	0x0015	Fib[7]	21	unsigned int
0x33	0x0022	Fib[8]	34	unsigned int

This window displays how variables with static storage duration, typically variables with file scope but also static variables in functions and classes, are laid out in memory. This can be useful for better understanding memory usage or for investigating problems caused by variables being overwritten, for example buffer overruns. Other areas of use are spotting alignment holes or for understanding problems caused by buffers being overwritten.



To view the memory corresponding to a variable, you can select it in the editor window and drag it to the **Symbolic Memory** window.

See also *Editing in C-SPY windows*, page 60.

### Requirements

Can be used with all C-SPY debugger drivers and debug probes.

### Toolbar

The toolbar contains:

#### Go to

The memory location or symbol you want to view.

#### Zone

Selects a memory zone, see *C-SPY memory zones*, page 165.

**Previous**

Highlights the previous symbol in the display area.

**Next**

Highlights the next symbol in the display area.

**Display area**

This area contains these columns:

**Location**

The memory address.

**Data**

The memory contents in hexadecimal format. The data is grouped according to the size of the symbol. This column is editable.

**Variable**

The variable name—requires that the variable has a fixed memory location. Local variables are not displayed.

**Value**

The value of the variable. This column is editable.

**Type**

The type of the variable.

There are several different ways to navigate within the memory space:

- Text that is dropped in the window is interpreted as symbols
- The scroll bar at the right-side of the window
- The **Next** and **Previous** toolbar buttons
- The **Go to** toolbar list box can be used for locating specific locations or symbols.

**Note:** Rows are marked in red when the corresponding value has changed.



## Context menu

This context menu is available:

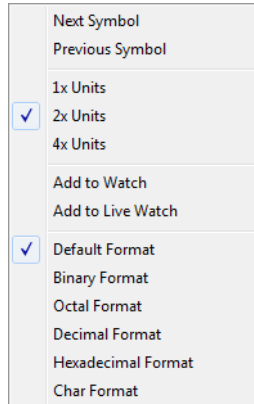

These commands are available:

### Next Symbol

Highlights the next symbol in the display area.

### Previous Symbol

Highlights the previous symbol in the display area.

### 1x Units

Displays the memory contents as single bytes. This applies only to rows that do not contain a variable.

### 2x Units

Displays the memory contents as 2-byte groups.

### 4x Units

Displays the memory contents as 4-byte groups.

### Add to Watch

Adds the selected symbol to the **Watch** window.

### Add to Live Watch

Adds the selected symbol to the **Live Watch** window.

### Default format

Displays the memory contents in the default format.

### Binary format

Displays the memory contents in binary format.

**Octal format**

Displays the memory contents in octal format.

**Decimal format**

Displays the memory contents in decimal format.

**Hexadecimal format**

Displays the memory contents in hexadecimal format.

**Char format**

Displays the memory contents in char format.

## Stack window

The **Stack** window is available from the **View** menu.

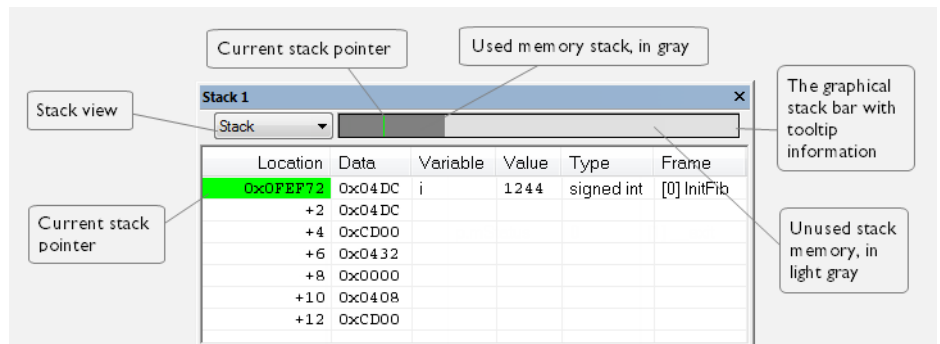

This window is a memory window that displays the contents of the stack. The graphical stack bar shows stack usage.

This window retrieves information about the stack size and placement from the definition in the linker configuration file of the sections holding the stacks. The sections are described in the *IAR C/C++ Development Guide for Arm*. For applications that set up the stacks using other mechanisms, you can to override the default mechanism. Use one of the C-SPY command line option variants, see `--proc_stack_stack`, page 566.

**Note:** By default, this window uses one physical breakpoint. For more information, see *Breakpoint consumers*, page 130.

For information about options specific to the **Stack** window, see the *IDE Project Management and Building Guide for Arm*.

### Requirements

Can be used with all C-SPY debugger drivers and debug probes.

## Toolbar

The toolbar contains:

### Stack

Selects which stack to view. This applies to cores with multiple stacks.

## The graphical stack bar

Displays the state of the stack graphically.

The left end of the stack bar represents the bottom of the stack, in other words, the position of the stack pointer when the stack is empty. The right end represents the end of the memory address range reserved for the stack. The graphical stack bar turns red when the stack usage exceeds a threshold that you can specify.

To enable the stack bar, choose **Tools>Options>Stack>Enable graphical stack display and stack usage tracking**. This means that the functionality needed to detect and warn about stack overflows is enabled.



Place the mouse pointer over the stack bar to get tooltip information about stack usage.

## Display area

This area contains these columns:

### Location

Displays the location in memory. The addresses are displayed in increasing order. The address referenced by the stack pointer, in other words the top of the stack, is highlighted in a green color.

### Data

Displays the contents of the memory unit at the given location. From the **Stack** window context menu, you can select how the data should be displayed—as a 1-, 2-, or 4-byte group of data.

### Variable

Displays the name of a variable, if there is a local variable at the given location. Variables are only displayed if they are declared locally in a function, and located on the stack and not in registers.

### Value

Displays the value of the variable.

### Type

Displays the data type of the variable.

**Frame**

Displays the name of the function that the call frame corresponds to.

**Context menu**

This context menu is available:

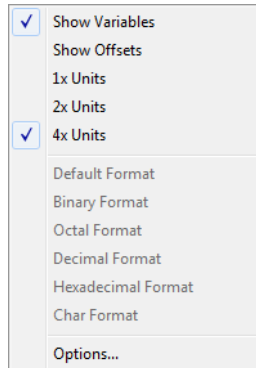

These commands are available:

**Show Variables**

Displays separate columns named **Variables**, **Value**, and **Frame** in the **Stack** window. Variables located at memory addresses listed in the **Stack** window are displayed in these columns.

**Show Offsets**

Displays locations in the **Location** column as offsets from the stack pointer. When deselected, locations are displayed as absolute addresses.

**1x Units**

Displays the memory contents as single bytes.

**2x Units**

Displays the memory contents as 2-byte groups.

**4x Units**

Displays the memory contents as 4-byte groups.

**Default Format****Binary Format****Octal Format****Decimal Format****Hexadecimal Format****Char Format**

Changes the display format of expressions. The display format setting affects different types of expressions in different ways. Your selection of display format is saved between debug sessions. These commands are available if a selected line in the window contains a variable.

The display format setting affects different types of expressions in these ways:

<b>Variables</b>	The display setting affects only the selected variable, not other variables.
<b>Array elements</b>	The display setting affects the complete array, that is, the same display format is used for each array element.
<b>Structure fields</b>	All elements with the same definition—the same field name and C declaration type—are affected by the display setting.

**Options**

Opens the **IDE Options** dialog box where you can set options specific to the **Stack** window, see the *IDE Project Management and Building Guide for Arm*.

## Registers window

The **Registers** windows are available from the **View** menu.

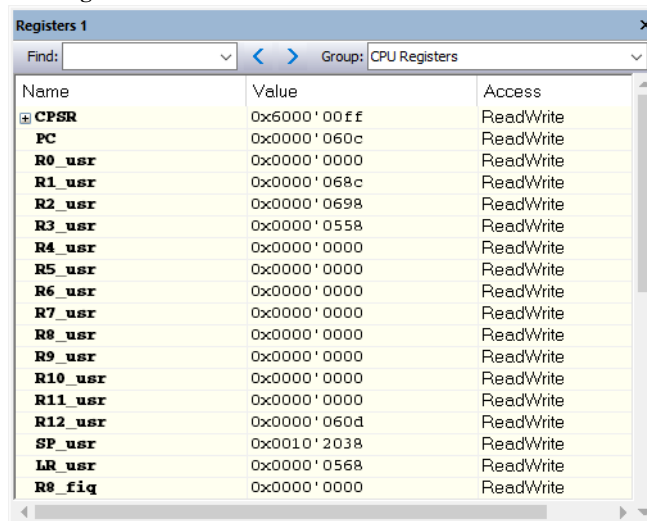

Name	Value	Access
<b>CPSR</b>	0x6000'00ff	ReadWrite
<b>PC</b>	0x0000'060c	ReadWrite
<b>R0_usr</b>	0x0000'0000	ReadWrite
<b>R1_usr</b>	0x0000'068c	ReadWrite
<b>R2_usr</b>	0x0000'0698	ReadWrite
<b>R3_usr</b>	0x0000'0558	ReadWrite
<b>R4_usr</b>	0x0000'0000	ReadWrite
<b>R5_usr</b>	0x0000'0000	ReadWrite
<b>R6_usr</b>	0x0000'0000	ReadWrite
<b>R7_usr</b>	0x0000'0000	ReadWrite
<b>R8_usr</b>	0x0000'0000	ReadWrite
<b>R9_usr</b>	0x0000'0000	ReadWrite
<b>R10_usr</b>	0x0000'0000	ReadWrite
<b>R11_usr</b>	0x0000'0000	ReadWrite
<b>R12_usr</b>	0x0000'060d	ReadWrite
<b>SP_usr</b>	0x0010'2038	ReadWrite
<b>LR_usr</b>	0x0000'0568	ReadWrite
<b>R9_fiq</b>	0x0000'0000	ReadWrite

These windows give an up-to-date display of the contents of the processor registers and special function registers, and allow you to edit the contents of some of the registers. Optionally, you can choose to load either predefined register groups or your own user-defined groups.

You can open up to four instances of this window, which is convenient for keeping track of different register groups.

See also *Editing in C-SPY windows*, page 60.

### To enable predefined register groups:

- 1 Select a device description file that suits your device, see *Selecting a device description file*, page 57. These files contain predefined register groups.
- 2 Display the registers of a register group by selecting it from the **Group** drop-down menu on the toolbar, or by right-clicking in the window and choosing **View Group** from the context menu.

For information about creating your own user-defined register groups, see *Defining application-specific register groups*, page 167.

### Requirements

Can be used with all C-SPY debugger drivers and debug probes.

## Toolbar

The toolbar contains:

### Find

Specify the name, or part of a name, of a register (or group) that you want to find. Press the Enter key and the first matching register, or group with a matching register, is displayed. User-defined register groups are not searched. The search box preserves a history of previous searches. To repeat a search, select it from the search history and press Enter.

### Group

Selects which predefined register group to display. By default, there are two register groups in the debugger. If some of your SFRs are missing, you can register your own SFRs in a Custom group, see *SFR Setup window*, page 191.

**Current CPU Registers** contains the registers that are available in the current processor mode.

**CPU Registers** contains both the current registers and their banked counterparts available in other processor modes.

Additional register groups are predefined in the device description files—available in the `arm\config` directory—that make all SFR registers available in the **Registers** windows. The device description file contains a section that defines the special function registers and their groups.

## Display area

Displays registers and their values. Some registers are expandable, which means that the register contains interesting bits or subgroups of bits.

If you drag a numerical value, a valid expression, or a register name from another part of the IDE to an editable value cell in a **Registers** window, the value will be changed to that of what you dragged. If you drop a register name somewhere else in the window, the window contents will change to display the first register group where this register is found.

### Name

The name of the register.

### Value

The current value of the register. Every time C-SPY stops, a value that has changed since the last stop is highlighted. Some of the registers are editable. To edit the contents of an editable register, click on the register and modify its value. Press Esc to cancel the change.

To change the display format of the value, right-click on the register and choose **Format** from the context menu.

### Access

The access type of the register. Some of the registers are read-only, while others are write-only.

For the C-SPY Simulator (and some C-SPY hardware debugger drivers), these additional support registers are available in the CPU Registers group:

<b>CYCLECOUNTER</b>	Cleared when an application is started or reset, and is incremented with the number of used cycles during execution.
<b>CCSTEP</b>	Shows the number of used cycles during the last performed C/C++ source or assembler step.
<b>CCTIMER1</b> and <b>CCTIMER2</b>	Two <i>trip counts</i> that can be cleared manually at any given time. They are incremented with the number of used cycles during execution.

### Context menu

This context menu is available:

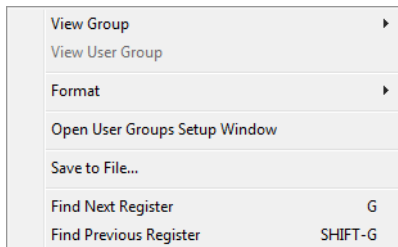

These commands are available:

#### View Group

Selects which predefined register group to display.

#### View User Group

Selects which user-defined register group to display. For information about creating your own user-defined register groups, see *Defining application-specific register groups*, page 167.



**Format**

Changes the display format for the contents of the register you clicked on. The display format setting affects different types of registers in different ways. Your selection of display format is saved between debug sessions.

**Open User Groups Setup Window**

Opens a window where you can create your own user-defined register groups, see *Register User Groups Setup window*, page 189.

**Save to File**

Opens a standard **Save** dialog box to save the contents of the window to a tab-separated text file.

**Find Next Register**

Finds the predefined register or register group that comes immediately after what your search found. After the last register was found, this search wraps around and finds the first register again.

**Find Previous Register**

Finds the matching predefined register or register group that comes immediately before what your search found. After the first register was found, this search wraps around and finds the last register again.

**Register User Groups Setup window**

The **Register User Groups Setup** window is available from the **View** menu or from the context menu in the **Registers** windows.

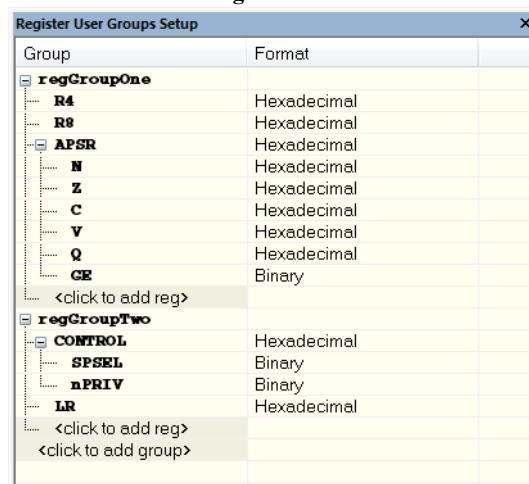

Use this window to define your own application-specific register groups. These register groups can then be viewed in the **Registers** windows.

Defining application-specific register groups means that the **Registers** windows can display just those registers that you need to watch for your current debugging task. This makes debugging much easier.

## Requirements

Can be used with all C-SPY debugger drivers and debug probes.

## Display area

This area contains these columns:

### Group

The names of register groups and the registers they contain. Clicking on <click to add group> or <click to add reg> and typing the name of a register group or register, adds new groups and registers, respectively. You can also drag a register name from another window in the IDE. Click a name to change it.

A dimmed register name indicates that it is not supported by the selected device.

### Format

Shows the display format for the register's value. To change the display format of the value, right-click on the register and choose **Format** from the context menu. The selected format is used in all **Registers** windows.

## Context menu

This context menu is available:

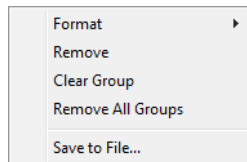

These commands are available:

### Format

Changes the display format for the contents of the register you clicked on. The display format setting affects different types of registers in different ways. Your selection of display format is saved between debug sessions.

### Remove

Removes the register or group you clicked on.

**Clear Group**

Removes all registers from the group you clicked on.

**Remove All Groups**

Deletes all user-defined register groups from your project.

**Save to File**

Opens a standard **Save** dialog box to save the contents of the window to a tab-separated text file.

## SFR Setup window

The **SFR Setup** window is available from the **Project** menu.

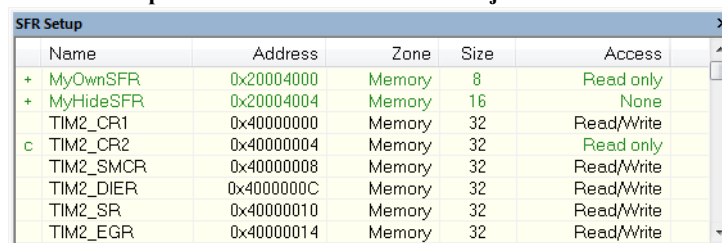

Name	Address	Zone	Size	Access
+ MyOwnSFR	0x20004000	Memory	8	Read only
+ MyHideSFR	0x20004004	Memory	16	None
TIM2_CR1	0x40000000	Memory	32	Read/Write
c TIM2_CR2	0x40000004	Memory	32	Read only
TIM2_SMCR	0x40000008	Memory	32	Read/Write
TIM2_DIER	0x4000000C	Memory	32	Read/Write
TIM2_SR	0x40000010	Memory	32	Read/Write
TIM2_EGR	0x40000014	Memory	32	Read/Write

This window displays the currently defined SFRs that C-SPY has information about. You can choose to display only factory-defined or custom-defined SFRs, or both. If required, you can use the **Edit SFR** dialog box to customize the SFR definitions, see *Edit SFR dialog box*, page 194. For factory-defined SFRs (that is, retrieved from the `addf` file in use), you can only customize the access type.

To quickly find an SFR, drag a text or hexadecimal number string and drop in this window. If what you drop starts with a 0 (zero), the **Address** column is searched, otherwise the **Name** column is searched.

Any custom-defined SFRs are added to a dedicated register group called Custom, which you can choose to display in the **Registers** window. Your custom-defined SFRs are saved in `projectCustomSFR.sfr`. This file is automatically loaded in the IDE when you start C-SPY with a project whose name matches the prefix of the filename of the `sfr` file.

You can only add or modify SFRs when the C-SPY debugger is not running.

**Requirements**

Can be used with all C-SPY debugger drivers and debug probes.

## Display area

This area contains these columns:

### Status

A character that signals the status of the SFR, which can be one of:

blank, a factory-defined SFR.

C, a factory-defined SFR that has been modified.

+, a custom-defined SFR.

?, an SFR that is ignored for some reason. An SFR can be ignored when a factory-defined SFR has been modified, but the SFR is no longer available, or it is located somewhere else or with a different size. Typically, this might happen if you change to another device.

### Name

A unique name of the SFR.

### Address

The memory address of the SFR.

### Zone

Selects a memory zone, see *C-SPY memory zones*, page 165.

### Size

The size of the register, which can be any of **8**, **16**, **32**, or **64**.

### Access

The access type of the register, which can be one of **Read/Write**, **Read only**, **Write only**, or **None**.

You can click a name or an address to change the value. The hexadecimal 0x prefix for the address can be omitted, the value you enter will still be interpreted as hexadecimal. For example, if you enter 4567, you will get 0x4567.

You can click a column header to sort the SFRs according to the column property.

Color coding used in the display area:

- Green, which indicates that the corresponding value has changed
- Red, which indicates an ignored SFR.

## Context menu

This context menu is available:

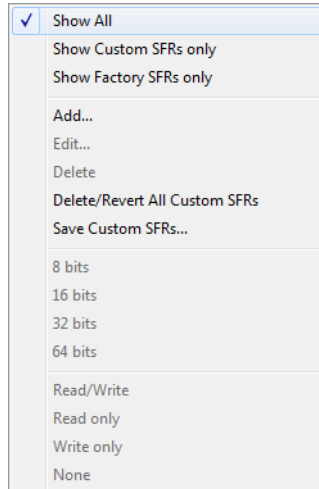

These commands are available:

### Show All

Shows all SFR.

### Show Custom SFRs only

Shows all custom-defined SFRs.

### Show Factory SFRs only

Shows all factory-defined SFRs retrieved from the ddf file.

### Add

Displays the **Edit SFR** dialog box where you can add a new SFR, see *Edit SFR dialog box*, page 194.

### Edit

Displays the **Edit SFR** dialog box where you can edit an SFR, see *Edit SFR dialog box*, page 194.

### Delete

Deletes an SFR. This command only works on custom-defined SFRs.

### Delete/Revert All Custom SFRs

Deletes all custom-defined SFRs and reverts all modified factory-defined SFRs to their factory settings.

**Save Custom SFRs**

Opens a standard **Save** dialog box to save all custom-defined SFRs.

**8|16|32|64 bits**

Selects display format for the selected SFR, which can be **8**, **16**, **32**, or **64** bits. Note that the display format can only be changed for custom-defined SFRs.

**Read/Write|Read only|Write only|None**

Selects the access type of the selected SFR, which can be **Read/Write**, **Read only**, **Write only**, or **None**. Note that for factory-defined SFRs, the default access type is indicated.

**Edit SFR dialog box**

The **Edit SFR** dialog box is available from the context menu in the **SFR Setup** window.

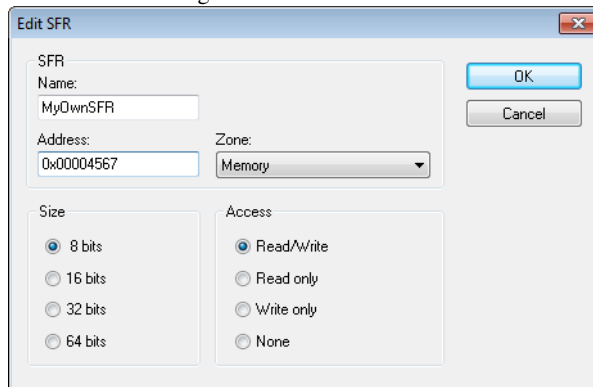

Definitions of the SFRs are retrieved from the device description file in use. Use this dialog box to either modify these factory-defined definitions or define new SFRs. See also *SFR Setup window*, page 191.

**Requirements**

Can be used with all C-SPY debugger drivers and debug probes.

**Name**

Specify the name of the SFR that you want to add or edit.

**Address**

Specify the address of the SFR that you want to add or edit. The hexadecimal 0x prefix for the address can be omitted, the value you enter will still be interpreted as hexadecimal. For example, if you enter 4567, you will get 0x4567.

**Zone**

Selects the memory zone for the SFR you want to add or edit. The list of zones is retrieved from the `ddf` file that is currently used.

**Size**

Selects the size of the SFR. Choose between **8**, **16**, **32**, or **64** bits. Note that the display format can only be changed for custom-defined SFRs.

**Access**

Selects the access type of the SFR. Choose between **Read/Write**, **Read only**, **Write only**, or **None**. Note that for factory-defined SFRs, the default access type is indicated.

## Memory Configuration dialog box for the C-SPY simulator

The Memory Configuration dialog box is available from the C-SPY driver menu.

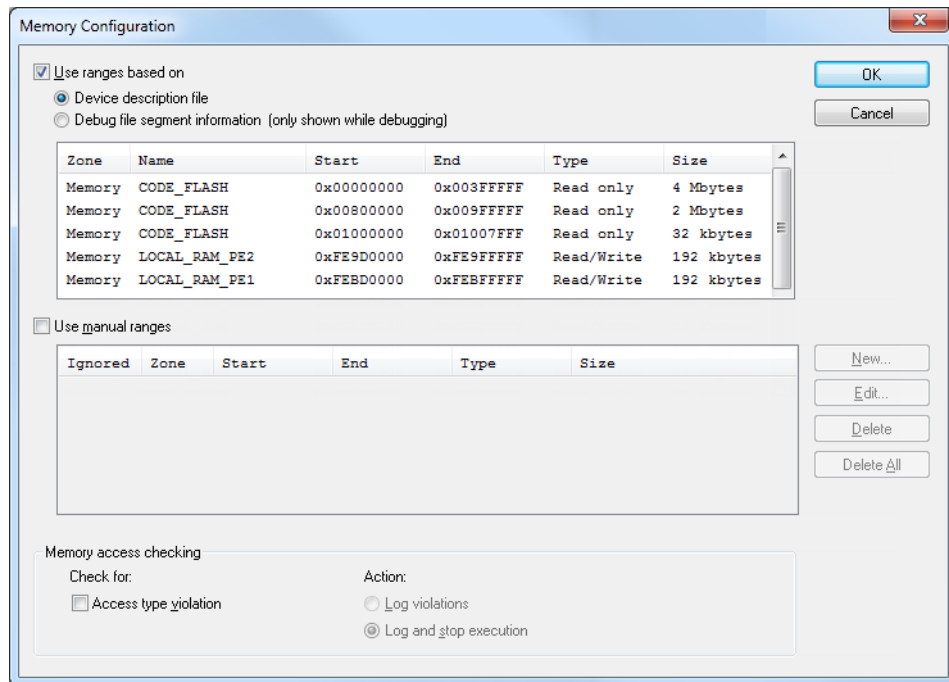

Use this dialog box to specify which set of memory address ranges to be used by C-SPY during debugging.

See also *Memory configuration for the C-SPY simulator*, page 165.

### Requirements

The C-SPY simulator.

### Use ranges based on

Specify if the memory configuration should be retrieved from a predefined configuration. Choose between:

#### Device description file

Retrieves the memory configuration from the device description file that you have specified. See *Selecting a device description file*, page 57.

This option is used by default.



**Debug file segment information**

Retrieves the memory configuration from the debug file, which has retrieved it from the linker configuration file. This information is only available during a debug session. The advantage of using this option is that the simulator can catch memory accesses outside the linked application.

Memory information is displayed in these columns:

**Zone**

The memory zone, see *C-SPY memory zones*, page 165.

**Name**

The name of the memory address range.

**Start**

The start address for the memory address range, in hexadecimal notation.

**End**

The end address for the memory address range, in hexadecimal notation.

**Type**

The access type of the memory address range.

**Size**

The size of the memory address range.

**Use manual ranges**

Specify your own ranges manually via the **Edit Memory Range** dialog box. To open this dialog box, click **New** to specify a new memory address range, or select an existing memory address range and click **Edit** to modify it. For more information, see *Edit Memory Range dialog box for the C-SPY simulator*, page 198.

The ranges you define manually are saved between debug sessions.

An **X** in the column **Ignored** means that C-SPY has detected that the specified manual range is illegal, for example because it overlaps another range. C-SPY will not use such an area.

**Memory access checking**

**Check for** determines what to check for:

- **Access type violation.**

**Action** selects the action to be performed if an access violation occurs. Choose between:

- **Log violations**
- **Log and stop execution.**

Any violations are logged in the **Debug Log** window.

## Buttons

These buttons are available for the manual ranges:

### New

Opens the **Edit Memory Range** dialog box, where you can specify a new memory address range and associate an access type with it, see *Edit Memory Range dialog box for the C-SPY simulator*, page 198.

### Edit

Opens the **Edit Memory Range** dialog box, where you can edit the selected memory address range. See *Edit Memory Range dialog box for the C-SPY simulator*, page 198.

### Delete

Deletes the selected memory address range definition.

### Delete All

Deletes all defined memory address range definitions.

## Edit Memory Range dialog box for the C-SPY simulator

The **Edit Memory Range** dialog box is available from the **Memory Configuration** dialog box.

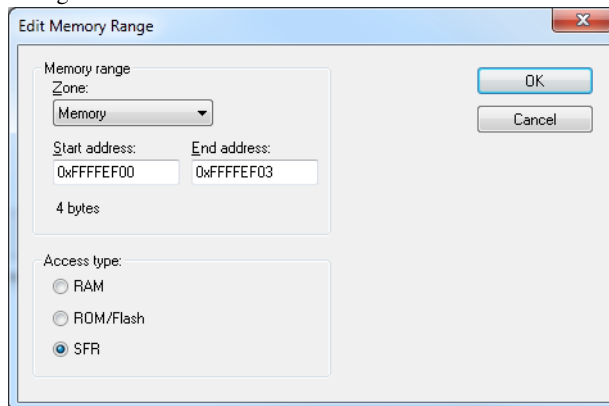

Use this dialog box to specify your own memory address ranges, and their access types.

See also *Memory Configuration dialog box for the C-SPY simulator*, page 196

**Requirements**

The C-SPY simulator.

**Memory range**

Defines the memory address range specific to your device:

**Zone**

Selects a memory zone, see *C-SPY memory zones*, page 165.

**Start address**

Specify the start address for the memory address range, in hexadecimal notation.

**End address**

Specify the end address for the memory address range, in hexadecimal notation.

**Access type**

Selects an access type for the memory address range. Choose between:

- **RAM**, for read/write memory
- **ROM/Flash**, for read-only memory
- **SFR**, for SFR read/write memory.

## Memory Configuration dialog box for C-SPY hardware debugger drivers

The Memory Configuration dialog box is available from the C-SPY driver menu.

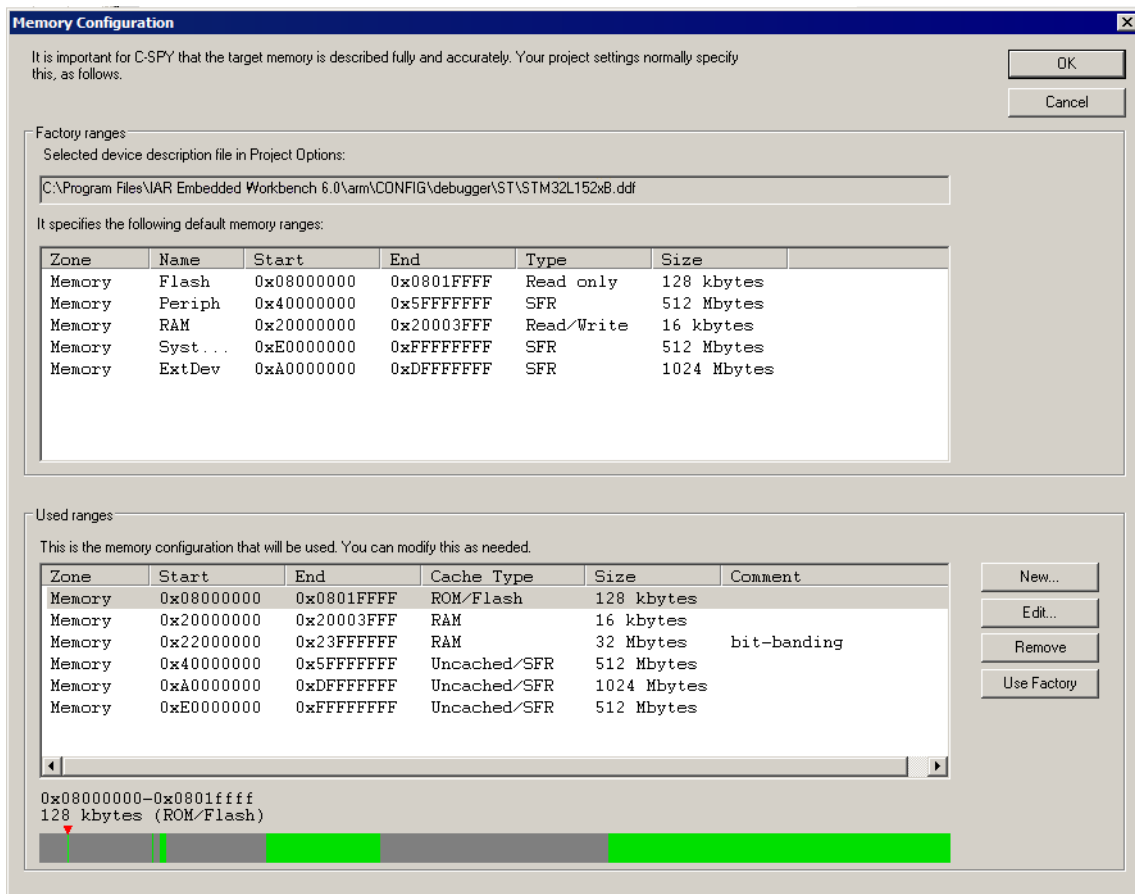

C-SPY uses a default memory configuration based on information retrieved from the device description file that you select, or if memory configuration is missing in the device description file, tries to provide a usable factory default. See *Selecting a device description file*, page 57.

Use this dialog box to verify, and if needed, modify the memory areas so that they match the memory available on your device. Providing C-SPY with information about the

memory layout of the target system is helpful both in terms of performance and functionality:

- Reading (and writing) memory (if your debug probe is connected through a USB port) can be fast, but is usually the limiting factor when C-SPY needs to update many debugger windows. Caching memory can speed up the performance, but then C-SPY needs information about the target memory.
- If C-SPY has been informed that the content of certain memory areas will be changed during a debug session, C-SPY can keep a copy of that memory readable even when the target does not normally allow reading (such as when executing).
- C-SPY can prevent accesses to areas without any memory at all, which can be important for certain hardware.

The **Memory Configuration** dialog box is automatically displayed the first time you start the C-SPY driver for a given project, unless the device description file contains a memory description which is already specified as correct and complete. Subsequent starts will not display the dialog box unless you have made project changes that might cause the memory configuration to change, for example, if you have selected another device description file.

You can only change the memory configuration when C-SPY is not running.

See also *Memory configuration for C-SPY hardware debugger drivers*, page 166.

## Requirements

One of these alternatives:

- The C-SPY I-jet driver
- The C-SPY J-Link/J-Trace driver
- The C-SPY ST-LINK driver
- The C-SPY CMSIS-DAP driver
- The C-SPY GDB Server driver
- The C-SPY TI MSP-FET driver
- The C-SPY TI Stellaris driver
- The C-SPY TI XDS driver

## Factory ranges

Identifies which device description file that is currently selected and lists the default memory address ranges retrieved from the file in these columns:

### Zone

The memory zone, see *C-SPY memory zones*, page 165.

**Name**

The name of the memory address range.

**Start**

The start address for the memory address range, in hexadecimal notation.

**End**

The end address for the memory address range, in hexadecimal notation.

**Type**

The access type of the memory address range.

**Size**

The size of the memory address range.

**Used ranges**

These columns list the memory address ranges that will be used by C-SPY. The columns are normally identical to the factory ranges, unless you have added, removed, or modified ranges.

**Zone**

Selects a memory zone, see *C-SPY memory zones*, page 165.

**Start**

The start address for the memory address range, in hexadecimal notation.

**End**

The end address for the memory address range, in hexadecimal notation.

**Cache Type**

The cache type of the memory address range.

**Size**

The size of the memory address range.

**Comment**

Memory area information.

Use the buttons to override the default memory address ranges that are retrieved from the device description file.

**Graphical bar**

A graphical bar that visualizes the entire theoretical memory address range for the device. Defined ranges are highlighted in green.

## Buttons

These buttons are available for manual ranges:

### New

Opens the **Edit Memory Range** dialog box, where you can specify a new memory address range and associate a cache type with it, see *Edit Memory Range dialog box for C-SPY hardware debugger drivers*, page 203.

### Edit

Opens the **Edit Memory Range** dialog box, where you can edit the selected memory address area. See *Edit Memory Range dialog box for C-SPY hardware debugger drivers*, page 203.

### Remove

Removes the selected memory address range definition.

### Use Factory

Restores the list of used ranges to the factory ranges.

## Edit Memory Range dialog box for C-SPY hardware debugger drivers

The **Edit Memory Range** dialog box is available from the **Memory Configuration** dialog box.

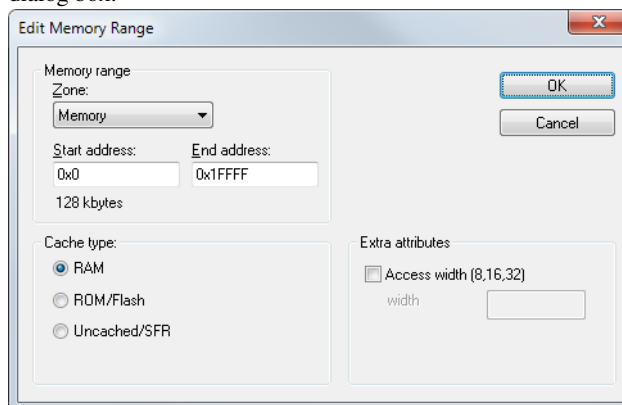

Use this dialog box to specify the memory address ranges, and assign a cache type to each range.

See also *Memory configuration for C-SPY hardware debugger drivers*, page 166.

## Requirements

One of these alternatives:

- The C-SPY I-jet driver
- The C-SPY J-Link/J-Trace driver
- The C-SPY ST-LINK driver
- The C-SPY CMSIS-DAP driver
- The C-SPY GDB Server driver
- The C-SPY TI MSP-FET driver
- The C-SPY TI Stellaris driver
- The C-SPY TI XDS driver

## Memory range

Defines the memory address range specific to your device:

### Zone

Selects a memory zone, see *C-SPY memory zones*, page 165.

### Start address

Specify the start address for the memory address range, in hexadecimal notation.

### End address

Specify the end address for the memory address range, in hexadecimal notation.

## Cache type

Selects a cache type to the memory address range. Choose between:

### RAM

When the target CPU is not executing, all read accesses from memory are loaded into the cache. For example, if two **Memory** windows show the same part of memory, the actual memory is only read once from the hardware to update both windows. If you modify memory from a C-SPY window, your data is written to cache only. Before any target execution, even stepping a single machine instruction, the RAM cache is flushed so that all modified bytes are written to the memory on your hardware.



**ROM/Flash**

This memory is assumed not to change during a debug session. Any code within such a range that is downloaded when you start a debug session (or technically, any such code that is part of the application being debugged) is stored in the cache and remains there. Other parts of such ranges are loaded into the cache from memory on demand, but are then kept during the debug session. Note that C-SPY will not allow you to modify such memory from C-SPY windows.

Even though flash memory is normally used as a fixed read-only memory, there are applications that modify parts of flash memory at runtime. For example, some part of flash memory might be used for a file system or simply to store non-volatile information. To reflect this in C-SPY, you should choose the **RAM** cache type for those instead. Then C-SPY will assume that those parts can change at any time during execution.

**SFR/Uncached**

A range of this type is completely uncached. All read or write commands from a C-SPY window will access the hardware immediately. Typically, this type is useful for special function registers, which can have all sorts of unusual behavior, such as having different values at every read access. This can in turn have side-effects on other registers when they are written, not containing the same value as was previously written, etc.

If you do not have the appropriate information about your device, you can specify an entire memory as **SFR/Uncached**. This is not incorrect, but might make C-SPY slower when updating windows. In fact, this caching type is sometimes used by the default when there is no memory address range information available.

If required, you can disable caching—choose *C-SPY driver*>**Disable Debugger Cache**.

**Extra attributes**

Provides extra attributes.

**Access width [8,16,32,64]**

Forces C-SPY to use 8, 16, 32, or 64-bit width when accessing memory in this range. Specify 8, 16, 32, or 64 in the text box.

This option might not be available in the C-SPY driver you are using.



# Part 2. Analyzing your application

This part of the *C-SPY® Debugging Guide for Arm* includes these chapters:

- Trace
- The application timeline
- Profiling
- Code coverage
- Performance monitoring
- Power debugging
- C-RUN runtime error checking





# Trace

- Introduction to using trace
- Collecting and using trace data
- Reference information on trace

---

## Introduction to using trace

These topics are covered:

- Reasons for using trace
- Briefly about trace
- Requirements for using trace

See also:

- *Getting started using data logging*, page 262
- *Getting started using event logging*, page 264
- *Power debugging*, page 321
- *Getting started using interrupt logging*, page 409
- *Profiling*, page 293

## REASONS FOR USING TRACE

By using trace, you can inspect the program flow up to a specific state, for instance an application crash, and use the trace data to locate the origin of the problem. Trace data can be useful for locating programming errors that have irregular symptoms and occur sporadically.

### Reasons for using the trace triggers and filters

By using trace trigger and filter conditions, you can select the interesting parts of your source code and use the trace buffer in the trace probe more efficiently. Trace triggers—Trace Start Trigger and Trace Stop Trigger breakpoints—specify for example a code section for which you want to collect trace data. A trace filter specifies conditions that, when fulfilled, activate the trace data collection during execution.

## BRIEFLY ABOUT TRACE

Your target system must be able to generate trace data. Once generated, C-SPY can collect it and you can visualize and analyze the data in various windows and dialog boxes.

C-SPY supports collecting trace data from these target systems:

- Devices with support for ETM (Embedded Trace Macrocell)—ETM trace
- Devices with support for the SWD (Serial Wire Debug) interface using the SWO (Serial Wire Output) communication channel—SWO trace
- For some cores and devices, the C-SPY simulator

Depending on your target system, different types of trace data can be generated.

### ETM trace

ETM (Embedded Trace Macrocell) real-time trace is a continuously collected sequence of every executed instruction for a selected portion of the execution. It is only possible to collect as much data as the trace buffer can hold. The trace buffer can be located either in the debug probe or on-chip (ETB or ETR). The trace buffer collects trace data in real time, but the data is not displayed in the C-SPY windows until after the execution has stopped.

### PTM trace

PTM (Program Trace Macrocell) is an alternative implementation of the trace logic used in some Arm Cortex cores. The functionality is the same as ETM trace.

Throughout this document, the term ETM also applies to PTM unless otherwise stated.

### ETB trace

ETB (Embedded Trace Buffer) trace is an on-chip trace buffer. For ETB trace, the trace buffer has a designated memory area with a predefined size.

### ETR trace

ETR (Embedded Trace Router) trace is a trace variant that uses an on-chip trace buffer. For ETR trace, the trace buffer shares the RAM memory with your application code and is configured in the project options.

### MTB trace

MTB trace (Micro Trace Buffer) is a simplified trace variant that uses an on-chip trace buffer. For MTB trace, the trace buffer shares the RAM memory with your application code.

MTB trace gives access to instruction trace on some devices based on the Cortex-M0+ and M23 cores.

### SWO trace

SWO trace is a sequence of events of various kinds, generated by the on-chip debug hardware. The events are transmitted in real time from the target system over the SWO communication channel. This means that the C-SPY windows are continuously updated while the target system is executing. The most important events are:

- *PC sampling*

The hardware can sample and transmit the value of the program counter at regular intervals. This is not a continuous sequence of executed instructions (like ETM trace), but a sparse regular sampling of the PC. A modern Arm CPU typically executes millions of instructions per second, while the PC sampling rate is usually counted in thousands per second.

- *Interrupt logs*

The hardware can generate and transmit data related to the execution of interrupts, generating events when entering and leaving an interrupt handler routine.

- *Data logs*

Using Data Log breakpoints, the hardware can be configured to generate and transmit events whenever a certain variable, or simply an address range, is accessed by the CPU.

The SWO channel has limited throughput, so it is usually not possible to use all the above features at the same time, at least not if either the frequency of PC sampling, of interrupts, or of accesses to the designated variables is high.

If you use the SWO communication channel on a trace probe, the data will be collected in the trace buffer and displayed after the execution has stopped.

### Trace features in C-SPY

In C-SPY, you can use the trace-related windows—**Trace**, **Function Trace**, **Timeline**, and **Find in Trace**. Depending on your C-SPY driver, you can set various types of trace breakpoints and triggers to control the collection of trace data.

If you use the C-SPY I-jet driver, the C-SPY J-Link/J-Trace driver, the C-SPY ST-LINK driver, or the C-SPY TI XDS driver, you have access to windows such as the **Interrupt Log**, **Interrupt Log Summary**, **Data Log**, and **Data Log Summary** windows.



When you are debugging, two buttons labeled **ETM** and **SWO**, respectively, are visible on the IDE main window toolbar. If either of these buttons are green, it means that the corresponding trace hardware is generating trace data. For detailed tooltip information about which C-SPY features have requested trace data generation, simply point at the

button with the mouse pointer. This is useful, for example, if your SWO communication channel often overflows because too many of the C-SPY features are currently using trace data. Clicking on the buttons opens the corresponding setup dialog boxes.

In addition, several other features in C-SPY also use trace data, features such as the Profiler, Code coverage, and Instruction profiling.

## REQUIREMENTS FOR USING TRACE

The C-SPY simulator supports trace-related functionality for some cores and devices. If supported, there are no further specific requirements.

**Note:** The specific set of debug components you are using (hardware, a debug probe, and a C-SPY driver) determine which trace features in C-SPY that are supported.

### Requirements for using ETM trace

ETM trace is available for some Arm devices.

To use ETMv3 trace, or earlier, you need one of these combinations:

- An I-jet Trace in-circuit debugging probe and a device that supports ETM via a physical trace port. Make sure to use the C-SPY I-jet driver.
- An I-jet or I-jet Trace in-circuit debugging probe and a device that supports ETM via ETB or ETR. The debug probe reads ETM data from the ETB or ETR buffer. Make sure to use the C-SPY I-jet driver.
- A J-Link or J-Trace debug probe and a device that supports ETM via ETB or ETR. The debug probe reads ETM data from the ETB or ETR buffer. Make sure to use the C-SPY J-Link/J-Trace driver.
- A J-Trace debug probe and a device that supports ETM via a physical trace port. Make sure to use the C-SPY J-Link/J-Trace driver.

To use ETMv4 trace, you need one of these combinations:

- An I-jet Trace in-circuit debugging probe and a device that supports ETM via a physical trace port. Make sure to use the C-SPY I-jet driver.
- An I-jet or I-jet Trace in-circuit debugging probe and a device that supports ETM via ETB or ETR. The debug probe reads ETM data from the ETB or ETR buffer. Make sure to use the C-SPY I-jet driver.

For more information, see the *IAR Debug probes User Guide for I-jet, I-jet Trace, and I-scope*, and the *IAR J-Link and IAR-J-Trace User Guide*, respectively.

**Note:** For ETB and ETR, the device support must implement specific trace support for either ETB or ETR. Specific setup sequences might also be needed in the corresponding device support macro files (`.dmac`).



### **Requirements for using MTB (Micro Trace Buffer) trace**

To use MTB trace, you need an M0+ or M23 device with MTB, and one of these alternatives:

- An I-jet in-circuit debugging probe
- The C-SPY CMSIS-DAP driver and a device that supports CMSIS-DAP
- A J-Link debug probe

### **Requirements for using SWO trace**

To use SWO trace you need an I-jet or I-jet Trace in-circuit debugging probe, a J-Link, J-Trace, an ST-LINK, or a TI XDS debug probe that supports the SWO communication channel and a device that supports the SWD/SWO interface.

### **Requirements for using the trace triggers and trace filters**

The trace triggering and trace filtering features are available for ETM, ETB, ETR, and PTM trace, but not for SWO or MTB trace.

Different processors, cores, and debug probes might limit the number of available trace triggers and filters.

---

## **Collecting and using trace data**

These tasks are covered:

- Getting started with ETM trace
- Getting started with SWO trace
- Getting started with MTB trace
- Setting up concurrent use of ETM and SWO
- Trace data collection using breakpoints
- Searching in trace data
- Browsing through trace data

## GETTING STARTED WITH ETM TRACE

- 1 Before you start C-SPY, you must set up the trace port for your device. For some devices this is done automatically when the trace logic is enabled. However, for some devices, typically Atmel and ST devices based on Arm 7 or Arm 9, you need to set up the trace port explicitly. You do this by means of a C-SPY macro file. You can find examples of such files (`ETM_init*.mac`) in the example projects. To use a macro file, choose **Project>Options>Debugger>Setup>Use macro files**. Specify your macro file—a browse button is available.

Note that the pins used on the hardware for the trace signals cannot be used by your application.

- 2 If your device uses ETR, specify the ETR trace buffer memory layout on the **Project>Options>Debugger>Extra options** tab. The available parameters are:
  - `--macro_param etrram`  
The start of the RAM area for trace storage, for example, `0x040A0000`. If not specified, ETB trace will be used instead of ETR trace.
  - `--macro_param etrsize`  
The size of the RAM area for trace storage, for example, `0x60000`.
  - `--macro_param etrport`  
The access port used to access the ETR RAM, for example, `1`. If not specified and if ETR is enabled, the port that is used to access the core will be used.
- 3 Start C-SPY and choose **ETM Trace Settings** from the C-SPY driver menu. In the **ETM Trace Settings** dialog box that appears, check if you need to change any of the default settings.
-  4 Open the **Trace** window—available from the driver-specific menu—and click the **Activate** button to enable collecting trace data.
- 5 Click the **Edit Settings** button to open the **ETM Trace Settings** dialog box. Make sure that the ETM registers and pins were properly initialized and that the debug probe receives the Trace Clock (TCLK). The dialog box displays the trace clock frequency which is received by the debug probe. Click **Cancel** to close the dialog box.
- 6 Start the execution. When the execution stops, for instance because a breakpoint is triggered, trace data is displayed in the **Trace** window. For more information, see *Trace window*, page 229.

## GETTING STARTED WITH SWO TRACE

- 1 Before you start C-SPY, choose **Project>Options>C-SPY driver**.  
Click the **Setup** tab or the **Connection** tab, respectively, and choose **Interface>SWD**.

- 2 After you have started C-SPY, choose **SWO Trace Windows Settings** from the *C-SPY driver* menu. In the dialog box that appears, make your settings for controlling the output in the **Trace** window.

To see statistical trace data, select the option **Force>PC samples**, see *SWO Trace Window Settings dialog box*, page 223.

- 3 To configure the hardware's generation of trace data, click the **SWO Configuration** button available in the **SWO Configuration** dialog box. For more information, see *SWO Configuration dialog box*, page 225.

Note specifically these settings:

- The value of the **CPU clock** option must reflect the frequency of the CPU clock speed at which the application executes. Note also that the settings you make are preserved between debug sessions.
- To decrease the amount of transmissions on the communication channel, you can disable the **Timestamp** option. Alternatively, set a lower rate for PC Sampling or use a higher SWO clock frequency.



- 4 Open the **SWO Trace** window—available from the *C-SPY driver* menu—and click the **Activate** button to enable trace data collection.
- 5 Start the execution. The **Trace** window is continuously updated with trace data. For more information about the window, see *Trace window*, page 229.

## GETTING STARTED WITH MTB TRACE

- 1 Before you start C-SPY, use *one* of these alternatives to configure the MTB trace buffer:
  - Define an array in RAM called `__mtb_trace_buffer` in your application, which the debugger will use as the trace buffer.
  - Define the two symbols `MTB_TRACE_BUFFER$$Base` and `MTB_TRACE_BUFFER$$Limit` in the linker configuration file (`.icf`). The debugger will use this information as the address and the size of the trace buffer.
  - Let the debugger automatically find some unused RAM space and use that as the trace buffer.
- 2 Start C-SPY.
- 3 Open the **Trace** window—available from the driver-specific menu—and click the **Activate** button to enable collecting trace data.
- 4 Start the execution. When the execution stops, for instance because a breakpoint is triggered, trace data is displayed in the **Trace** window. For more information, see *Trace window*, page 229.

## SETTING UP CONCURRENT USE OF ETM AND SWO

If you have a J-Trace debug probe for Cortex-M3, you can use ETM trace and SWO trace concurrently.

In this case, if you activate the ETM trace and the SWO trace, SWO trace data will also be collected in the ETM trace buffer, instead of being streamed via the SWO channel. This means that the SWO trace data will not be displayed until the execution has stopped, instead of being continuously updated live in the **SWO Trace** window.

## TRACE DATA COLLECTION USING BREAKPOINTS

A convenient way to collect trace data between two execution points is to start and stop the data collection using dedicated breakpoints.

Choose between these alternatives:

- In the editor or **Disassembly** window, position your insertion point, right-click, and toggle a **Trace Start Trigger** or **Trace Stop Trigger** breakpoint from the context menu.
- In the **Breakpoints** window, choose **New Breakpoint>Trace Start Trigger**, **Trace Stop Trigger**, or **Trace Filter** from the context menu.
- The C-SPY system macros `__setTraceStartBreak` and `__setTraceStopBreak` can also be used.

For more information about these breakpoints, see *Trace Start Trigger breakpoint dialog box*, page 239 and *Trace Stop Trigger breakpoint dialog box*, page 240, respectively.

### Using the trace triggers and trace filters:

- 1** Use the **Trace Start Trigger** dialog box to set a start condition—a start trigger—to start collecting trace data.
- 2** Use the **Trace Stop Trigger** dialog box to set a stop condition—a stop trigger—to stop collecting trace data.
- 3** Optionally, set additional conditions for the trace data collection to continue. Then set one or more trace filters, using the **Trace Filter** dialog box.
- 4** If needed, set additional trace start or trace stop conditions.
- 5** Enable the **Trace** window and start the execution.
- 6** Stop the execution.
- 7** You can view the trace data in the **Trace** window, and also in browse mode in the **Disassembly** window, where the trace marks for your trace triggers and trace filters are also visible.

- 8** If you have set a trace filter, the trace data collection is performed while the condition is true plus some further instructions. When viewing the trace data and looking for a certain data access, remember that the access took place one instruction earlier.

## SEARCHING IN TRACE DATA

When you have collected trace data, you can perform searches in the collected data to locate the parts of your code or data that you are interested in, for example, a specific interrupt or accesses of a specific variable.

You specify the search criteria in the **Find in Trace** dialog box and view the result in the **Find in Trace** window.

**Note:** The **Find in Trace** dialog box depends on the C-SPY driver you are using.

The **Find in Trace** window is very similar to the **Trace** window, showing the same columns and data, but *only* those rows that match the specified search criteria.

Double-clicking an item in the **Find in Trace** window brings up the same item in the **Trace** window.

### To search in your trace data:



- 1** On the **Trace** window toolbar, click the **Find** button.
- 2** In the **Find in Trace** dialog box, specify your search criteria.

Typically, you can choose to search for:

- A specific piece of text, for which you can apply further search criteria
- An address range
- A combination of these, like a specific piece of text within a specific address range.

For more information about the various options, see *Find in Trace dialog box*, page 253.

- 3** When you have specified your search criteria, click **Find**. The **Find in Trace** window is displayed, which means you can start analyzing the trace data. For more information, see *Find in Trace window*, page 255.

## BROWSING THROUGH TRACE DATA

To follow the execution history, simply look and scroll in the **Trace** window. Alternatively, you can enter *browse mode*.



To enter browse mode, double-click an item in the **Trace** window, or click the **Browse** toolbar button.

The selected item turns yellow and the source and **Disassembly** windows will highlight the corresponding location. You can now move around in the trace data using the up and down arrow keys, or by scrolling and clicking—the source and **Disassembly** windows

will be updated to show the corresponding location. This is like stepping backward and forward through the execution history.

Double-click again to leave browse mode.

---

## Reference information on trace

Reference information about:

- *ETM Trace Settings dialog box (I-jet)*, page 219
- *ETM Trace Settings dialog box (J-Link/J-Trace)*, page 221
- *SWO Trace Window Settings dialog box*, page 223
- *SWO Configuration dialog box*, page 225
- *Trace window*, page 229
- *Function Trace window*, page 238
- *Trace Start Trigger breakpoint dialog box*, page 239
- *Trace Stop Trigger breakpoint dialog box*, page 240
- *Trace Start breakpoints dialog box (I-jet and CMSIS-DAP)*, page 241
- *Trace Stop breakpoints dialog box (I-jet and CMSIS-DAP)*, page 243
- *Trace Filter breakpoints dialog box (I-jet)*, page 245
- *Trace Start breakpoints dialog box (J-Link/J-Trace)*, page 246
- *Trace Stop breakpoints dialog box (J-Link/J-Trace)*, page 249
- *Trace Filter breakpoints dialog box (J-Link/J-Trace)*, page 251
- *Find in Trace dialog box*, page 253
- *Find in Trace window*, page 255
- *Trace Save dialog box*, page 256

## ETM Trace Settings dialog box (I-jet)

The **ETM Trace Settings** dialog box is available from the C-SPY driver menu.

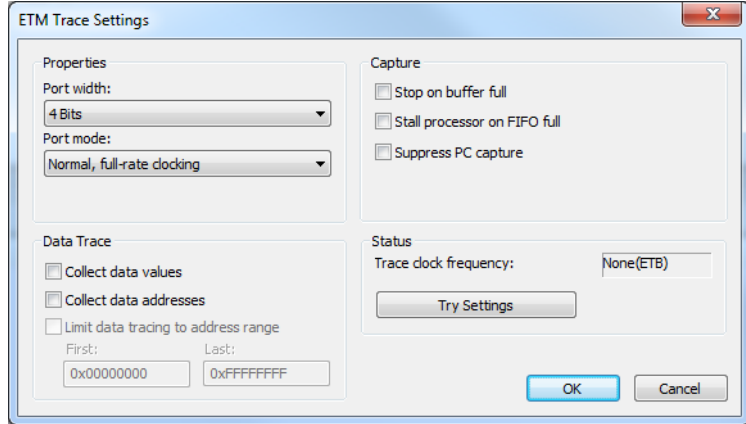

Use this dialog box to configure ETM trace generation and collection.

See also:

- *Requirements for using ETM trace*, page 212
- *Getting started with ETM trace*, page 214

### Requirements

One of these alternatives:

- The C-SPY I-jet driver
- The C-SPY CMSIS-DAP driver

### Port width

Specifies the trace bus width, which can be set to 1, 2, 4, 8, or 16-bits. The value must correspond with what is supported by the hardware and the debug probe.

For the lower values, the risk of FIFO buffer overflow increases, unless you are using the **Stall processor on FIFO full** option.

### Port mode

Specifies the used trace clock rate:

- Normal, full-rate clocking
- Normal, half-rate clocking

## Data Trace

Selects what type of trace data you want C-SPY to collect. Data trace is only available for Arm7/Arm9/Arm11-based devices with ETM data trace. Choose between:

### Collect data values

Collects data values.

### Collect data addresses

Collects data addresses.

### Limit data tracing to address range

Collects the specified type of data within the address range you specify in the **First** and **Last** text boxes.

## Capture

Normally, trace collection starts or stops when execution starts or stops, or when a Trace Start or Trace Stop breakpoint is triggered. To change this, choose between:

### Stop on buffer full

Stops collecting trace data when the probe buffer is full.

### Stall processor on FIFO full

Stalls the processor in case the FIFO buffer fills up. The trace FIFO buffer on the CPU might in some situations become full—FIFO buffer overflow—which means trace data will be lost. This can be the case when the CPU is executing several branch instructions close to each other in time, such as in tight loops.

### Suppress PC capture

Disables PC trace. Depending on your hardware, data trace might still be available.

## Status

Shows the ETM status.

### Trace clock frequency

Shows the frequency of the trace clock to help you determine if the trace hardware is properly configured. Typically, this depends on the settings of Port Width and Port Mode.

### Apply settings

Applies the settings you made in this dialog box. The trace clock frequency will be updated.



## ETM Trace Settings dialog box (J-Link/J-Trace)

The ETM Trace Settings dialog box is available from the C-SPY driver menu.

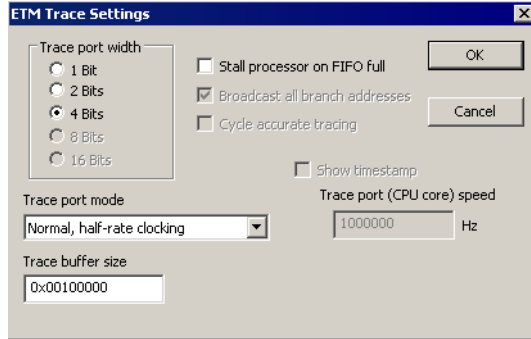

Use this dialog box to configure ETM trace generation and collection.

See also:

- *Requirements for using ETM trace*, page 212
- *Getting started with ETM trace*, page 214

### Requirements

The C-SPY J-Link/J-Trace driver.

### Trace port width

Specifies the trace bus width, which can be set to 1, 2, 4, 8, or 16 bits. The value must correspond with what is supported by the hardware and the debug probe. For Cortex-M3, 1, 2, and 4 bits are supported by the J-Trace debug probe. For Arm7/9, only 4 bits are supported by the J-Trace debug probe.

For the lower values, the risk of FIFO buffer overflow increases, unless you are using the **Stall processor on FIFO full** option.

### Trace port mode

Specifies the used trace clock rate:

- Normal, full-rate clocking
- Normal, half-rate clocking
- Multiplexed
- Demultiplexed
- Demultiplexed, half-rate clocking

**Note:** For the J-Trace driver, the available alternatives depend on the device you are using.

### Trace buffer size

Specify the size of the trace buffer. By default, the number of trace frames is 0xFFFF. For Arm7/9 the maximum number is 0xFFFFFF, and for Cortex-M3 the maximum number is 0x3FFFFFF.

For ARM7/9, one trace frame corresponds to 2 bytes of the physical J-Trace buffer size. For Cortex-M3, one trace frame corresponds to approximately 1 byte of the buffer size.

**Note:** The **Trace buffer size** option is only available for the J-Trace driver.

### Cycle accurate tracing

Emits trace frames synchronous to the processor clock even when no trace data is available. This makes it possible to use the trace data for real-time timing calculations. However, if you select this option, the risk for FIFO buffer overflow increases.

**Note:** This option is only available for Arm7/9 devices.

### Broadcast all branches

Makes the processor send more detailed address trace information. However, if you select this option, the risk for FIFO buffer overflow increases.

**Note:** This option is only available for Arm7/9 devices. For Cortex, this option is always enabled.

### Stall processor on FIFO full

Stalls the processor in case the FIFO buffer fills up. The trace FIFO buffer on the CPU might in some situations become full—FIFO buffer overflow—which means trace data will be lost. This can be the case when the CPU is executing several branch instructions close to each other in time, such as in tight loops.

### Show timestamp

Makes the **Trace** window display seconds instead of cycles in the **Index** column. To make this possible, you must also specify the appropriate speed for your CPU in the **Trace port (CPU core) speed** text box.

**Note:** This option is only available when you use the J-Trace driver with Arm7/9 devices.

## SWO Trace Window Settings dialog box

The **SWO Trace Window Settings** dialog box is available from the C-SPY driver menu, alternatively from the **SWO Trace** window toolbar.

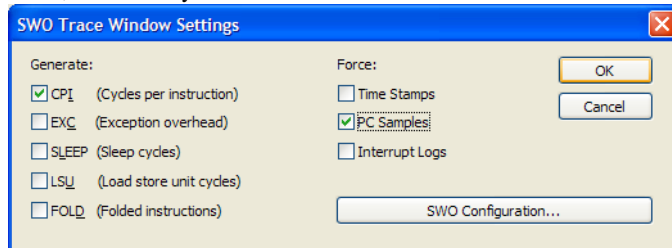

Use this dialog box to specify what to display in the **SWO Trace** window.

Note that you also need to configure the generation of trace data, click **SWO Configuration**. For more information, see *SWO Configuration dialog box*, page 225.

### Requirements

One of these alternatives:

- The C-SPY I-jet driver and an I-jet or I-jet Trace in-circuit debugging probe
- The C-SPY J-Link/J-Trace driver and a J-Link/J-Trace JTAG/SWD probe
- The C-SPY ST-LINK driver and an ST-LINK JTAG/SWD probe
- The C-SPY TI XDS driver and a TI XDS probe

### Force

Enables data generation, if it is not already enabled by other features using SWO trace data. The **Trace** window displays all generated SWO data. Other features in C-SPY, for example Profiling, can also enable SWO trace data generation. If no other feature has enabled the generation, use the **Force** options to generate SWO trace data.

The generated data will be displayed in the **Trace** window. Choose between:

#### Time Stamps

Enables timestamps for various SWO trace packets, that is sent over the SWO communication channel. Use the resolution drop-down list to choose the resolution of the timestamp value. For example, 1 to count every cycle, or 16 to count every 16th cycle. Note that the lowest resolution is only useful if the time between each event packet is long enough. 16 is useful if using a low SWO clock frequency.

This option does not apply to I-jet.

### **PC samples**

Enables sampling the program counter register, PC, at regular intervals. To choose the sampling rate, see *SWO Configuration dialog box*, page 225, specifically the option **PC Sampling**.

### **Interrupt Logs**

Forces the generation of interrupt logs to the **SWO Trace** window. For information about other C-SPY features that also use trace data for interrupts, see *Interrupts*, page 401.

### **ITM Log**

Forces the generation of ITM logs to the **SWO Trace** window.

This option only applies to I-jet.

## **Generate**

Enables trace data generation for these events. The generated data will be displayed in the **Trace** window. The value of the counters are displayed in the **Comment** column in the **SWO Trace** window. Choose between:

### **CPI**

Enables generation of trace data for the CPI counter.

### **EXC**

Enables generation of trace data for the EXC counter.

### **SLEEP**

Enables generation of trace data for the SLEEP counter.

### **LSU**

Enables generation of trace data for the LSU counter.

### **FOLD**

Enables generation of trace data for the FOLD counter.

## **SWO Configuration**

Displays the **SWO Configuration** dialog box where you can configure the hardware's generation of trace data. See *SWO Configuration dialog box*, page 225.

This button is not available when you are using I-jet.

## SWO Configuration dialog box

The **SWO Configuration** dialog box is available from the C-SPY driver menu, alternatively from the **SWO Trace Window Settings** dialog box.

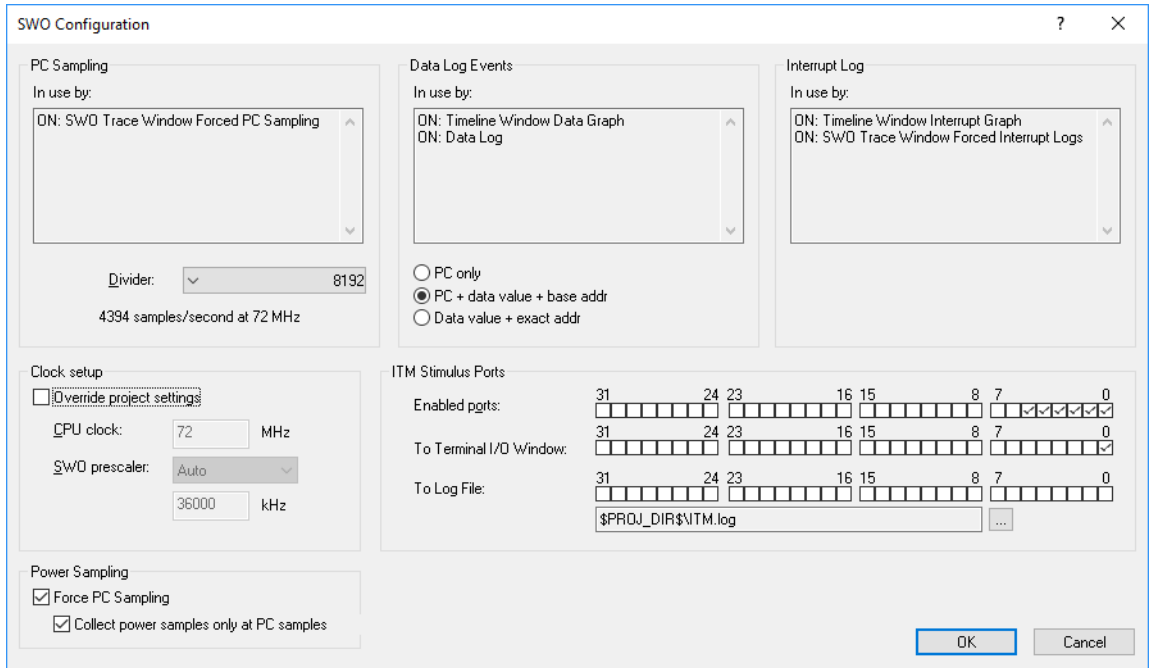

This figure reflects the C-SPY I-jet driver.

Use this dialog box to configure the serial-wire output communication channel and the hardware's generation of trace data.

See also *Getting started with SWO trace*, page 214.

### Requirements

One of these alternatives:

- The C-SPY I-jet driver and an I-jet or I-jet Trace in-circuit debugging probe
- The C-SPY J-Link/J-Trace driver and a J-Link/J-Trace JTAG/SWD probe
- The C-SPY ST-LINK driver and an ST-LINK JTAG/SWD probe
- The C-SPY TI XDS driver and a TI XDS probe

## PC Sampling

Controls the behavior of the sampling of the program counter. You can specify:

### In use by

Lists the features in C-SPY that can use trace data for PC sampling. ON indicates features currently using trace data. OFF indicates features currently not using trace data.

### Rate

Use the drop-down list to choose the sampling rate, that is, the number of samples per second. The highest possible sampling rate depends on the SWO clock value and on how much other data that is sent over the SWO communication channel. The higher values in the list will not work if the SWO communication channel is not fast enough to handle that much data.

This option does not apply to I-jet.

### Divider

Select a divider, that, applied to the CPU clock speed, determines the rate of PC samples. The highest possible sampling rate depends on the SWO clock value and on how much other data that is sent over the SWO communication channel. The smaller values in the list will not work if the SWO communication channel is not fast enough to handle that much data.

This option only applies to I-jet.

## Data Log Events

Specifies what to log when a Data Log breakpoint is triggered. These items are available:

### In use by

Lists the features in C-SPY that can use trace data for Data Log Events. ON indicates features currently using trace data. OFF indicates features currently not using trace data.

### PC only

Logs the value of the program counter.

### PC + data value + base addr

Logs the value of the program counter, the value of the data object, and its base address.

### Data value + exact addr

Logs the value of the data object and the exact address of the data object that was accessed.

### Interrupt Log

Lists the features in C-SPY that can use trace data for Interrupt Logs. ON indicates features currently using trace data. OFF indicates features currently not using trace data.

For more information about interrupt logging, see *Interrupts*, page 401.

### Override project default

Overrides the **CPU clock** and the **SWO clock** default values on the **Project>Options>J-Link/J-Trace>Setup** page, on the **Project>Options>ST-Link>Communication** page, or on the **Project>Options>TI XDS>Communication** page, respectively.

This option does not apply to I-jet.

### Override project settings

Overrides the **CPU clock** and the **SWO prescaler** default values on the **Project>Options>I-jet>Setup** page.

This option only applies to I-jet.

### CPU clock

Specify the exact clock frequency used by the internal processor clock, **HCLK**, in MHz. The value can have decimals.

This value is used for configuring the SWO communication speed.

For J-Link, ST-LINK, and TI XDS, this value is also used for calculating timestamps.

### SWO clock

Specify the clock frequency of the SWO communication channel in kHz. Choose between:

#### Autodetect

Automatically uses the highest possible frequency that the J-Link debug probe can handle. When it is selected, the Wanted text box displays that frequency.

#### Wanted

Manually selects the frequency to be used, if **Autodetect** is not selected. The value can have decimals. Use this option if data packets are lost during transmission.

#### Actual

Displays the frequency that is actually used. This can differ a little from the wanted frequency.

This option does not apply to I-jet.

### **SWO prescaler**

Specify the clock prescaler of the SWO communication channel. The prescaler, in turn, determines the SWO clock frequency. If data packets are lost during transmission, try using a higher prescaler value. Choose between:

#### **Auto**

Automatically uses the highest possible frequency that the I-jet debugging probe can handle.

#### **1, 2, 5, 10, 20, 50, 100**

The prescaler value.

This option only applies to I-jet.

### **Timestamps**

Selects the resolution of the timestamp value. For example, 1 to count every cycle, or 16 to count every 16th cycle. Note that the lowest resolution is only useful if the time between each event packet is long enough.

This option does not apply to I-jet.

### **ITM Stimulus Ports**

Selects which ports you want to redirect and to where. The ITM Stimulus Ports are used for sending data from your application to the debugger host without stopping the program execution. There are 32 such ports. Choose between:

#### **Enabled ports**

Enables the ports to be used. Only enabled ports will actually send any data over the SWO communication channel to the debugger.

Port 0 is used by the terminal I/O library functions.

Ports 1-4 are used by the ITM macros for the **Event Log** window.

Port 5 is used for an optional PC value added to the ITM macro.

#### **To Terminal I/O window**

Specifies the ports to use for routing data to the **Terminal I/O** window.

#### **To Log File**

Specifies the ports to use for routing data to a log file. To use a different log file than the default one, use the browse button.





The `stdout` and `stderr` of your application can be routed via SWO to the C-SPY **Terminal I/O** window, instead of via semihosting. To achieve this, choose **Project>Options>General Options>Library Configuration>Library low-level interface implementation>stdout/stderr>Via SWO**. This will significantly improve the performance of `stdout/stderr`, compared to when semihosting is used.

This can be disabled if you deselect the port settings in the **Enabled ports** and **To Terminal I/O** options.

## Power Sampling

### Force PC Sampling

Forces PC sampling, even when no other C-SPY features have requested it. This makes it possible to associate PC values with power samples.

### Collect power samples only at PC samples

Collects power samples only at PC samples, so that every power sample can be associated with a program counter position.

## Trace window

The **Trace** window is available from the C-SPY driver menu.

This window displays the collected trace data.

**Note:** There are three different trace windows—**ETM Trace**, **SWO Trace**, and just **Trace** for the C-SPY simulator. The windows look slightly different.

The content of the **Trace** window depends on the C-SPY driver you are using and the trace support of your debug probe.

See also *Collecting and using trace data*, page 213.

## Requirements

One of these alternatives:

- The C-SPY Simulator. (Not available for all cores and devices.)
- A CMSIS-DAP probe
- An I-jet or I-jet Trace in-circuit debugging probe
- A J-Link/J-Trace JTAG/SWD probe
- An ST-LINK JTAG/SWD probe
- A TI XDS probe

## Trace toolbar

The toolbar in the **Trace** window contains:



### Enable/Disable

Enables and disables collecting and viewing trace data in this window.



### Clear trace data

Clears the trace buffer. Both the **Trace** window and the **Function Trace** window are cleared.



### Toggle source

Toggles the **Trace** column between showing only disassembly or disassembly together with the corresponding source code.



### Browse

Toggles browse mode on or off for a selected item in the **Trace** window, see *Browsing through trace data*, page 217.



### Find

Displays a dialog box where you can perform a search, see *Find in Trace dialog box*, page 253.



### Save

In the **ETM Trace** and **SWO Trace** windows, this button displays the **Trace Save** dialog box, see *Trace Save dialog box*, page 256.

In the C-SPY I-jet driver and in the C-SPY simulator, this button displays a standard **Save As** dialog box where you can save the collected trace data to a text file, with tab-separated columns.



### Edit Settings

In the C-SPY simulator, this button is not enabled.

In the **ETM Trace** window this button displays the **Trace Settings** dialog box, see *ETM Trace Settings dialog box (J-Link/J-Trace)*, page 221 and *ETM Trace Settings dialog box (I-jet)*, page 219.

In the **SWO Trace** window this button displays the **SWO Trace Window Settings** dialog box, see *SWO Trace Window Settings dialog box*, page 223.

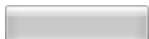

### Progress bar

When a large amount of trace data has been collected, there might be a delay before all of it has been processed and can be displayed. The progress bar reflects that processing.







## Display area (in the C-SPY simulator)

This area displays a collected sequence of executed machine instructions. In addition, the window can display trace data.

Timestamp	Trace	Read Addr	Read Data	Write Addr	Write Data
149	while (x < 1000000000) 0x66: LDR.N R0, [PC, #0x18]...				
149	0x66: LDR.N R0, [PC, #0x18]...	0x00000000	0x3b9aca00		
151	0x68: CMP R4, R0				
152	0x6a: BLT.N 0x5e				
156	x += sqr(x); 0x5e: MOV.S R0, R4				
157	0x60: BL sqr	...			
160	return x * x; sqr: 0x40: MULS R0, R0, R0				
161	0x42: BX LR				
165	0x64: ADDS R4, R0, R4				
166	while (x < 1000000000) 0x66: LDR.N R0, [PC, #0x18]...				
166	0x66: LDR.N R0, [PC, #0x18]...	0x00000000	0x3b9aca00		

This area contains these columns for the C-SPY simulator:

The leftmost column contains identifying icons to simplify navigation within the buffer:

-  The yellow diamond indicates the trace execution point, marking when target execution has started.
-  The right green arrow indicates a call instruction.
-  The left green arrow indicates a return instruction.
-  The dark green bookmark indicates a navigation bookmark.
-  The red arrow indicates an interrupt.
-  The violet bar indicates the results of a search.

### Timestamp

The number of cycles elapsed to this point.

### Trace

The collected sequence of executed machine instructions. Optionally, the corresponding source code can also be displayed.

### Read Addr, Read Data, Write Addr, Write Data

These columns show reads and writes to memory.

A red-colored row indicates that the previous row and the red row are not consecutive. This means that there is a gap in the collected trace data, for example because trace data has been lost due to an overflow.

### Display area (for ETM trace in the C-SPY hardware debugger drivers)

This area displays a collected sequence of executed machine instructions and other trace data.

Timestamp	Address	Exec	Trace	Except
113528	0x0021028a	Thumb	SUBS R0, R4, #1	
>	113530	0x0021028c	Thumb BL arm_pow2 ; 0x2102b2	
			arm unsigned int arm_pow2(int n)	
			{	
			PUSH {R3-R5, LR}	
			MOVSW R4, R0	
			if (n <= 0)	
			CMP R4, #1	
			void SysTick_Handler(void)	
			{	
▶	113538	0x00212478	Thumb PUSH {R7, LR}	SysTick
			HAL_IncTick();	
>	113540	0x0021247a	Thumb BL HAL_IncTick ; 0x212484	
			uwTick++;	
			LDR.N R0, [PC, #0x8] ; uwTick	
			LDR R0, [R0]	
■	113546	0x00212488	Thumb ADDSW R0, R0, #1	
			LDR.N R1, [PC, #0x4] ; uwTick	
			STR R0, [R1]	
			}	
<	113552	0x0021248e	Thumb BX LR	
			SysTickHandler();	
>	113554	0x0021247e	Thumb BL SysTickHandler ; 0x21039a	

Data trace is only available for the C-SPY I-jet driver or CMSIS-DAP driver, when using Arm7/Arm9/Arm11-based devices with ETM data trace.

This area contains these columns. Note that some columns depend on the C-SPY driver, the CPU, and the probe you are using.

The leftmost column contains identifying icons to simplify navigation within the buffer:

- ◆ The yellow diamond indicates the trace execution point, marking when target execution has started.
- ▶ The right green arrow indicates a call instruction.
- ◀ The left green arrow indicates a return instruction.
- The dark green bookmark indicates a navigation bookmark.
- ▶ The red arrow indicates an interrupt.
- The violet bar indicates the results of a search.

**Timestamp**

The internal I-jet Trace timestamp.

**Address**

The address of the instruction associated with the trace frame.

**Opcode**

The operation code of the instruction associated with the trace frame. After the hexadecimal value, extra information can be displayed:

x2 — if two instructions were executed

C — if the instruction was read from the I-Cache

**Exec**

The execution mode—`ARM`, `Thumb`, or `NoExec`.

**Trace**

The collected sequence of executed machine instructions. Optionally, the corresponding source code can also be displayed.

**Except**

The type of exception, when it occurs.

**Access**

The access type of the instruction associated with the trace frame. `DMA` stands for DMA transfer. The address and data information shows which transfer that was performed.

**Data address**

The data trace address.

**Data value**

The data trace value.

**Comment**

Additional information.

A red-colored row indicates that the previous row and the red row are not consecutive. This means that there is a gap in the collected trace data, for example because trace data has been lost due to an overflow.

**Display area (for SWO trace)**

This area contains these columns for SWO trace:

**SWO Packet**

The contents of the captured SWO packet, displayed as a hexadecimal value.

**Cycles**

The approximate number of cycles from the start of the execution until the event.

For J-Link, this number is reported by the CPU.

For I-jet, this number corresponds to the internal I-jet Trace timestamp.

**Event**

The event type of the captured SWO packet. If the column displays `Overflow`, the data packet could not be sent, because too many SWO features use the SWO channel at the same time. To decrease the amount of transmissions on the communication channel, point at the **SWO** button—on the IDE main window toolbar—with the mouse pointer to get detailed tooltip information about which C-SPY features that have requested trace data generation. Disable some of the features.

**Value**

The event value, if any.

**Trace**

If the event is a sampled PC value, the disassembled instruction is displayed in this column. Optionally, the corresponding source code can also be displayed.

**Comment**

Additional information, including the values of the selected Trace Events counters, or the number of the comparator (hardware breakpoint) used for the Data Log breakpoint.

A red-colored row indicates that the previous row and the red row are not consecutive. This means that there is a gap in the collected trace data, for example because trace data has been lost due to an overflow.



If the display area seems to show garbage, make sure you specified a correct value for the **CPU clock** in the **SWO Configuration** dialog box.

## Context menu

This context menu is available:

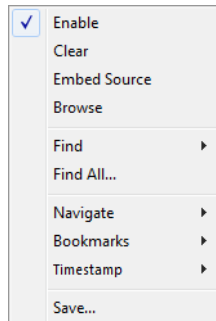

**Note:** The contents of this menu are dynamic and depend on which features that your combination of software and hardware supports. However, the list of menu commands below is complete and covers all possible commands. Note that the shortcuts to the submenu commands do not use the Ctrl key.

These commands are available:

### Enable

Enables and disables collecting and viewing trace data in this window.

### Clear

Clears the trace buffer. Both the **Trace** window and the **Function Trace** window are cleared.

### Embed source

Toggles the **Trace** column between showing only disassembly or disassembly together with the corresponding source code.

### Browse

Toggles browse mode on or off for a selected item in the **Trace** window, see *Browsing through trace data*, page 217.

### Find>Find (F)

Displays a dialog box where you can perform a search in the **Trace** window, see *Find in Trace dialog box*, page 253. The contents of the window will scroll to display the first match.

### Find>Find Next (G)

Finds the next occurrence of the specified string.

### Find>Find Previous (Shift+G)

Finds the previous occurrence of the specified string.

**Find>Clear (Shift+F)**

Removes all search highlighting in the window.

**Find All**

Displays a dialog box where you can perform a search in the **Trace** window, see *Find in Trace dialog box*, page 253. The search results are displayed in the **Find in Trace** window—available by choosing the **View>Messages** command, see *Find in Trace window*, page 255.

**Navigate>After Current Loop (L)**

Identifies the selected program counter and scans the trace data forward, collecting program counters, until it finds the same address again. It has now detected a loop. (Loops longer than 1000 instructions are not detected.) Then it navigates forward until it finds a program counter that is not part of the collected set. This is useful for navigating out of many iterations of an idle or polling loop.

**Navigate>Before Current Loop (Shift+L)**

Behaves as **After Current Loop**, but navigates backward out of the loop.

**Navigate>After Current Function (U)**

Navigates to the next unmatched return instruction. This is similar to stepping out of the current function.

**Navigate>Before Current Function (Shift+U)**

Navigates to the closest previous unmatched call instruction.

**Navigate>Next Statement (S)**

Navigates to the next instruction that belongs to a different C statement than the starting point. It skips function calls, i.e. it tries to reach the next statement in the starting frame.

**Navigate>Previous Statement (Shift+S)**

Behaves as **Next statement**, but navigates backward to the closest previous different C statement.

**Navigate>Next on Same Address (A)**

Navigates to the next instance of the starting program counter address, typically to the next iteration of a loop.

**Navigate>Previous on Same Address (Shift+A)**

Navigates to the closest previous instance of the starting program counter address.

**Navigate>Next Interrupt (I)**

Navigates to the next interrupt entry. (To then find the matching interrupt exit, follow up with **After Current Function**.)



**Navigate>Previous Interrupt (Shift+I)**

Navigates to the closest previous interrupt entry.

**Navigate>Next Execution Start Point (E)**

Navigates to the next point where the CPU was started, for example places where the application stopped at breakpoints, or was stepped.

**Navigate>Previous Execution Start Point (Shift+E)**

Navigates to the closest previous point where the CPU was started.

**Navigate>Next Discontinuity (D)**

Navigates to the next discontinuity in the trace data.

**Navigate>Previous Discontinuity (Shift+D)**

Navigates to the closest previous discontinuity in the trace data.

**Bookmarks>Toggle (+)**

Adds a new navigation bookmark or removes an existing bookmark.

**Bookmarks>Goto Next (B)**

Navigates to the next navigation bookmark.

**Bookmarks>Goto Previous (Shift+B)**

Navigates to the closest previous navigation bookmark.

**Bookmarks>Clear All**

Removes all navigation bookmarks.

**Bookmarks>location (0–9)**

At the bottom of the submenu, the ten most recently defined bookmarks are listed, with a shortcut key each from 0–9.

**Timestamp>Set as Zero Point (Z)**

Sets the selected row as a reference “zero” point in the collected sequence of trace data. The count of rows in the **Trace** window will show this row as 0 and recalculate the timestamps of all other rows in relation to this timestamp.

**Timestamp>Go to Zero Point (Shift+Z)**

Navigates to the reference “zero” point in the collected sequence of trace data (if you have set one).

**Timestamp>Clear Zero Point**

Removes the reference “zero” point from the trace data and restores the original timestamps of all rows.

### Save

In the **ETM Trace** and **SWO Trace** windows, this button displays the **Trace Save** dialog box, see *Trace Save dialog box*, page 256.

In the C-SPY I-jet driver and in the C-SPY simulator, this button displays a standard **Save As** dialog box where you can save the collected trace data to a text file, with tab-separated columns.

## Function Trace window

The **Function Trace** window is available from the C-SPY driver menu during a debug session.

Timestamp	Address	Call/Return
0		<discontinuity>
12	0x8000023C	__low_level_init
14	0x8000002E	__iar_program_start + 46
16	0x8000015A	__iar_data_init2
28	0x80000214	__iar_copy_init2
106	0x8000017A	__iar_data_init2 + 32
112	0x80000034	__iar_program_start + 52

This window displays a subset of the trace data displayed in the **Trace** window. Instead of displaying all rows, the **Function Trace** window shows:

- The functions called or returned to, instead of the traced instruction
- The corresponding trace data.

### Requirements

One of these alternatives:

- The C-SPY Simulator. (Not available for all cores and devices.)
- An I-jet or I-jet Trace in-circuit debugging probe
- A J-Link/J-Trace JTAG/SWD probe
- An ST-LINK JTAG/SWD probe
- A TI XDS probe

### Display area

There are two sets of columns available, and which set is used in your debugging system depends on the debug probe and which trace sources that are available:

- The available columns are the same as in the **Trace** window, see *Trace window*, page 229.

- For the simulator, I-jet Trace, and I-jet and depending on the trace source, these columns are available:

#### Timestamp

The number of cycles elapsed to this point according to the timestamp in the debug probe.

#### Address

The address of the executed instruction.

#### Call/Return

The function that was called or returned to.

## Trace Start Trigger breakpoint dialog box

The **Trace Start Trigger** dialog box is available from the context menu that appears when you right-click in the **Breakpoints** window.

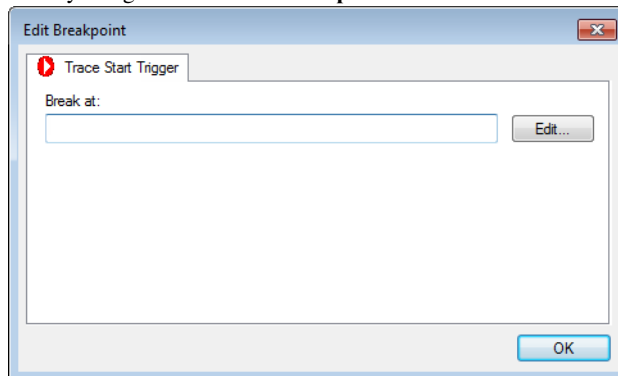

Use this dialog box to set a Trace Start Trigger breakpoint where you want to start collecting trace data. If you want to collect trace data only for a specific range, you must also set a Trace Stop Trigger breakpoint where you want to stop collecting data.

See also *Trace Stop Trigger breakpoint dialog box*, page 240 and *Trace data collection using breakpoints*, page 216.

#### To set a Trace Start Trigger breakpoint:

- 1 In the editor or **Disassembly** window, right-click and choose **Trace Start Trigger** from the context menu.  
Alternatively, open the **Breakpoints** window by choosing **View>Breakpoints**.
- 2 In the **Breakpoints** window, right-click and choose **New Breakpoint>Trace Start Trigger**.

Alternatively, to modify an existing breakpoint, select a breakpoint in the **Breakpoints** window and choose **Edit** on the context menu.

- 3 In the **Break at** text box, specify an expression, an absolute address, or a source location. Click **OK**.
- 4 When the breakpoint is triggered, the trace data collection starts.

### Requirements

The C-SPY simulator. Not available for all cores and devices.

### Break At

Specify the code location of the breakpoint in the text box. Alternatively, click the **Edit** button to open the **Enter Location** dialog box, see *Enter Location dialog box*, page 159.

## Trace Stop Trigger breakpoint dialog box

The **Trace Stop Trigger** dialog box is available from the context menu that appears when you right-click in the **Breakpoints** window.

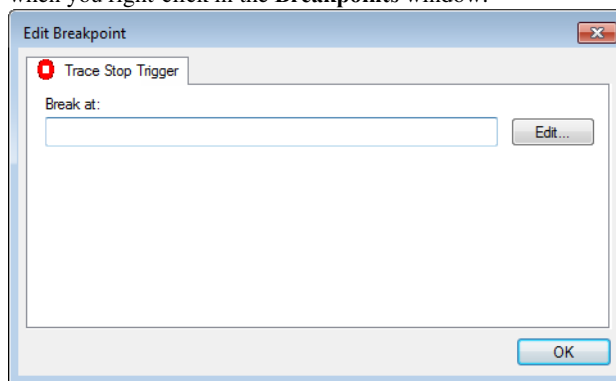

Use this dialog box to set a Trace Stop Trigger breakpoint where you want to stop collecting trace data. If you want to collect trace data only for a specific range, you might also need to set a Trace Start Trigger breakpoint where you want to start collecting data.

See also *Trace Start Trigger breakpoint dialog box*, page 239 and *Trace data collection using breakpoints*, page 216.

### To set a Trace Stop Trigger breakpoint:

- 1 In the editor or **Disassembly** window, right-click and choose **Trace Stop Trigger** from the context menu.

Alternatively, open the **Breakpoints** window by choosing **View>Breakpoints**.

- 2 In the **Breakpoints** window, right-click and choose **New Breakpoint>Trace Stop Trigger**.

Alternatively, to modify an existing breakpoint, select a breakpoint in the **Breakpoints** window and choose **Edit** on the context menu.

- 3 In the **Break at** text box, specify an expression, an absolute address, or a source location. Click **OK**.
- 4 When the breakpoint is triggered, the trace data collection stops.

### Requirements

The C-SPY simulator. Not available for all cores and devices.

### Break At

Specify the code location of the breakpoint in the text box. Alternatively, click the **Edit** button to open the **Enter Location** dialog box, see *Enter Location dialog box*, page 159.

## Trace Start breakpoints dialog box (I-jet and CMSIS-DAP)

The **Trace Start** dialog box is available from the context menu that appears when you right-click in the **Breakpoints** window. You can also right-click in the editor window or the **Disassembly** window, and then choose **Toggle Breakpoint (Trace Start)**.

Use this dialog box to set the conditions that determine when to start collecting trace data. When the trace condition is triggered, the trace data collection is started.

### Requirements

One of these alternatives:

- The C-SPY I-jet driver

- The C-SPY CMSIS-DAP driver
- A device with data matching capabilities.

### Trigger at

Specify the starting point of the code section for which you want to collect trace data. You can specify a variable name, an address, or a cycle counter value.

### Access Type

Selects the type of memory access that triggers the breakpoint:

#### Read/Write

Reads from or writes to location.

#### Read

Reads from location.

#### Write

Writes to location.

#### Fetch

Accesses at execution address.

Any accesses of the specified type will activate the trace data collection.

### Match data

Enables matching of the accessed data. Choose between:

**Value** Specify a data value.

**Mask** Specify which part of the value to match (word, halfword, or byte).

Use the **Match data** options in combination with the Read/Write, Read, or Write access types for data. This option can be useful when you want a trigger when a variable has a certain value.

**Note:** The **Match data** options are only available when using a Cortex-M device. For Cortex-M devices, only one breakpoint with **Match data** can be set. Such a breakpoint uses two breakpoint resources.

**Size**

Controls the size of the address range, that when reached, will trigger the start of the trace data collection. Choose between:

**Auto**

Sets the size automatically. This can be useful if **Trigger at** contains a variable.

**Manual**

Specify the size of the breakpoint range manually.

**Trigger range**

Shows the requested range and the effective range to be covered by the trace data collection. The range suggested is either within or exactly the area specified by the **Trigger at** and the **Size** options.

**Extend to cover requested range**

Extends the range so that a whole data structure is covered. For data structures that do not fit the size of the possible ranges supplied by the hardware breakpoint unit, for example three bytes, the range will not cover the whole data structure. Note that the range will be extended beyond the size of the data structure, which might cause false triggers at adjacent data.

This option is not enabled for Arm7/9 devices because the range for such devices will always cover the whole data structure.

**Trace Stop breakpoints dialog box (I-jet and CMSIS-DAP)**

The **Trace Stop** dialog box is available from the context menu that appears when you right-click in the **Breakpoints** window. You can also right-click in the editor window or the **Disassembly** window, and then choose **Toggle Breakpoint (Trace Stop)**.

The dialog box is titled "Trace Stop breakpoints dialog box (I-jet and CMSIS-DAP)". It contains the following elements:

- Trigger at:** A text input field with an "Edit ..." button to its right.
- Access type:** A group box containing four radio buttons: "Read/Write", "Read", "Write", and "Fetch".
- Match data:** A group box containing an "Enable" checkbox, a "Value:" text input field, and a "Mask:" text input field.
- Size:** A group box containing two radio buttons: "Auto" and "Manual", and a text input field.
- Trigger range:** A group box containing two text input fields: "Requested:" and "Effective:". Below these is a checkbox labeled "Extend to cover requested range".

Use this dialog box to set the conditions that determine when to stop collecting trace data. When the trace condition is triggered, the trace data collection is stopped.

### Requirements

One of these alternatives:

- The C-SPY I-jet driver
- The C-SPY CMSIS-DAP driver

### Trigger at

Specify the end point of the code section for which you want to collect trace data. You can specify a variable name, an address, or a cycle counter value.

### Access Type

Selects the type of memory access that triggers the breakpoint:

#### Read/Write

Reads from or writes to location.

#### Read

Reads from location.

#### Write

Writes to location.

#### Fetch

Accesses at execution address.

Any accesses of the specified type will activate the trace data collection.

### Match data

Enables matching of the accessed data. Choose between:

**Value** Specify a data value.

**Mask** Specify which part of the value to match (word, halfword, or byte).

Use the **Match data** options in combination with the Read/Write, Read, or Write access types for data. This option can be useful when you want a trigger when a variable has a certain value.

**Note:** The **Match data** options are only available when using a Cortex-M device. For Cortex-M devices, only one breakpoint with **Match data** can be set. Such a breakpoint uses two breakpoint resources.



**Size**

Controls the size of the address range, that when reached, will trigger the start of the trace data collection. Choose between:

**Auto**

Sets the size automatically. This can be useful if **Trigger at** contains a variable.

**Manual**

Specify the size of the breakpoint range manually.

**Trigger range**

Shows the requested range and the effective range to be covered by the trace data collection. The range suggested is either within or exactly the area specified by the **Trigger at** and the **Size** options.

**Extend to cover requested range**

Extends the range so that a whole data structure is covered. For data structures that do not fit the size of the possible ranges supplied by the hardware breakpoint unit, for example three bytes, the range will not cover the whole data structure. Note that the range will be extended beyond the size of the data structure, which might cause false triggers at adjacent data.

This option is not enabled for Arm7/9 devices because the range for such devices will always cover the whole data structure.

**Trace Filter breakpoints dialog box (I-jet)**

The **Trace Filter** dialog box is available from the context menu that appears when you right-click in the **Breakpoints** window. You can also right-click in the editor window or the **Disassembly** window, and then choose **Toggle Breakpoint (Trace Filter)**.

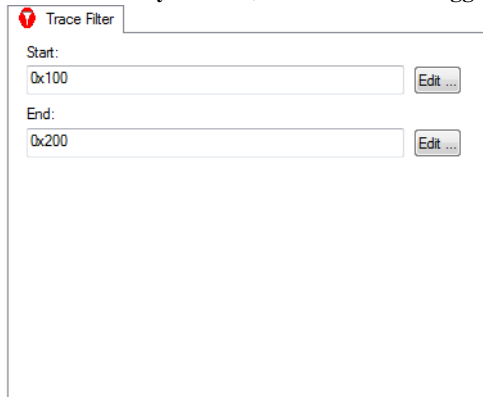

Use this dialog box to set the conditions that determine when to start collecting trace data. When the trace condition is triggered, the trace data collection is started.

### Requirements

One of these alternatives:

- The C-SPY I-jet driver
- The C-SPY CMSIS-DAP driver

### Start

Specify the start location of the code section for which you want to collect trace data. Alternatively, click the **Edit** button to open the **Enter Location** dialog box, see *Enter Location dialog box*, page 159.

### End

Specify the end location of the code section for which you want to collect trace data. Alternatively, click the **Edit** button to open the **Enter Location** dialog box, see *Enter Location dialog box*, page 159.

## Trace Start breakpoints dialog box (J-Link/J-Trace)

The **Trace Start** dialog box is available from the context menu that appears when you right-click in the **Breakpoints** window. You can also right-click in the editor window or the **Disassembly** window, and then choose **Toggle Breakpoint (Trace Start)**.

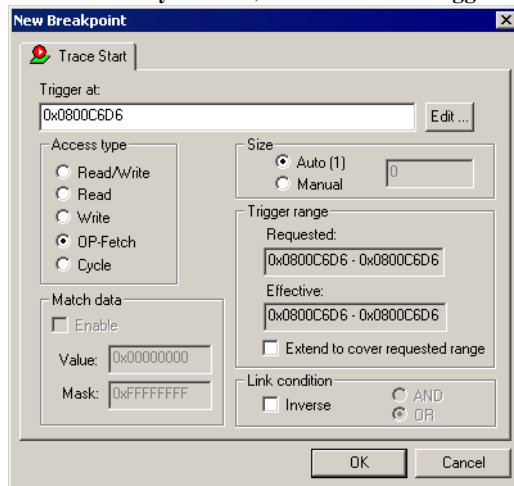

Use this dialog box to set the conditions that determine when to start collecting trace data. When the trace condition is triggered, the trace data collection is started.

**Requirements**

The C-SPY J-Link/J-Trace driver.

**Trigger at**

Specify the starting point of the code section for which you want to collect trace data. You can specify a variable name, an address, or a cycle counter value.

**Size**

Controls the size of the address range, that when reached, will trigger the start of the trace data collection. Choose between:

**Auto**

Sets the size automatically. This can be useful if **Trigger at** contains a variable.

**Manual**

Specify the size of the breakpoint range manually.

**Trigger range**

Shows the requested range and the effective range to be covered by the trace data collection. The range suggested is either within or exactly the area specified by the **Trigger at** and the **Size** options.

**Extend to cover requested range**

Extends the range so that a whole data structure is covered. For data structures that do not fit the size of the possible ranges supplied by the hardware breakpoint unit, for example three bytes, the range will not cover the whole data structure. Note that the range will be extended beyond the size of the data structure, which might cause false triggers at adjacent data.

This option is not enabled for Arm7/9 devices because the range for such devices will always cover the whole data structure.

**Access Type**

Selects the type of memory access that triggers the breakpoint:

**Read/Write**

Reads from or writes to location.

**Read**

Reads from location.

**Write**

Writes to location.

**OP-fetch**

Accesses at execution address.

**Cycle**

The number of counter cycles at a specific point in time, counted from where the execution started. This option is only available for Cortex-M devices.

Any accesses of the specified type will activate the trace data collection.

**Match data**

Enables matching of the accessed data. Use the **Match data** options in combination with the Read/Write, Read, or Write access types for data. This option can be useful when you want a trigger when a variable has a certain value.

**Value** Specify a data value.

**Mask** Specify which part of the value to match (word, halfword, or byte).

The **Match data** options are only available for J-Link/J-Trace and when using a Cortex-M device.

**Note:** For Cortex-M devices, only one breakpoint with **Match data** can be set. Such a breakpoint uses two breakpoint resources.

**Link condition**

Specifies how trace conditions are combined, using **AND** and **OR**. When combining a condition that has the link condition **AND** with a condition that has the link condition **OR**, **AND** has precedence. The option **Inverse** inverts the trace condition and is individual for each trace filter condition. If one trace start or stop condition is inverted, all others will be too. An inverted trace start or stop condition means that the trace data collection is performed everywhere except for this section of the application code.

For Arm7/9 devices, trace filters are combined using the OR algorithm. Use the **Inverse** option to invert the trace filter—all trace filters are affected. The trace filter will be combined with the start and stop triggers, if any, using the AND algorithm.

## Trace Stop breakpoints dialog box (J-Link/J-Trace)

The **Trace Stop** dialog box is available from the context menu that appears when you right-click in the **Breakpoints** window. You can also right-click in the editor window or the **Disassembly** window, and then choose **Toggle Breakpoint (Trace Stop)**.

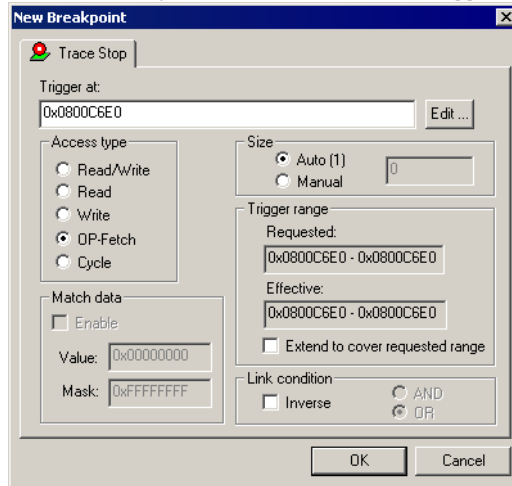

When the trace condition is triggered, the trace data collection is performed for some further instructions, and then the collection is stopped.

### Requirements

The C-SPY J-Link/J-Trace driver.

### Trigger at

Specify the stopping point of the code section for which you want to collect trace data. You can specify a variable name, an address, or a cycle counter value.

### Size

Controls the size of the address range, that when reached, will trigger the stop of the trace data collection. Choose between:

#### Auto

Sets the size automatically. This can be useful if **Trigger at** contains a variable.

#### Manual

Specify the size of the breakpoint range manually.

**Trigger range**

Shows the requested range and the effective range to be covered by the trace data collection. The range suggested is either within or exactly the area specified by the **Trigger at** and the **Size** options.

**Extend to cover requested range**

Extends the range so that a whole data structure is covered. For data structures that do not fit the size of the possible ranges supplied by the hardware breakpoint unit, for example three bytes, the range will not cover the whole data structure. Note that the range will be extended beyond the size of the data structure, which might cause false triggers at adjacent data.

This option is not enabled for Arm7/9 devices because the range for such devices will always cover the whole data structure.

**Access Type**

Selects the type of memory access that triggers the breakpoint:

**Read/Write**

Reads from or writes to location.

**Read**

Reads from location.

**Write**

Writes to location.

**OP-fetch**

Accesses at execution address.

**Cycle**

The number of counter cycles at a specific point in time, counted from where the execution started. This option is only available for Cortex-M devices.

Any accesses of the specified type will stop the trace data collection.

**Match data**

Enables matching of the accessed data. Use the **Match data** options in combination with the Read/Write, Read, or Write access types for data. This option can be useful when you want a trigger when a variable has a certain value.

**Value** Specify a data value.

**Mask** Specify which part of the value to match (word, halfword, or byte).

The **Match data** options are only available for J-Link/J-Trace and when using a Cortex-M device.

**Note:** For Cortex-M devices, only one breakpoint with **Match data** can be set. Such a breakpoint uses two breakpoint resources.

### Link condition

Specifies how trace conditions are combined, using **AND** and **OR**. When combining a condition that has the link condition **AND** with a condition that has the link condition **OR**, **AND** has precedence. The option **Inverse** inverts the trace condition and is individual for each trace filter condition. If one trace start or stop condition is inverted, all others will be too. An inverted trace start or stop condition means that the trace data collection is performed everywhere except for this section of the application code.

For Arm7/9 devices, trace filters are combined using the OR algorithm. Use the **Inverse** option to invert the trace filter—all trace filters are affected. The trace filter will be combined with the start and stop triggers, if any, using the AND algorithm.

## Trace Filter breakpoints dialog box (J-Link/J-Trace)

The **Trace Filter** dialog box is available from the context menu that appears when you right-click in the Breakpoints window. You can also right-click in the editor window or the Disassembly window, and then choose **Toggle Breakpoint (Trace Filter)**.

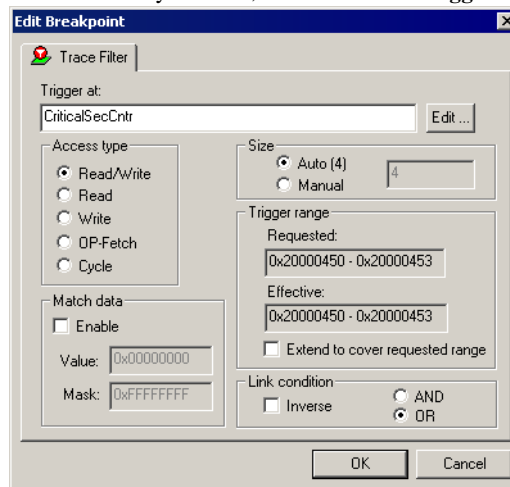

When the trace condition is triggered, the trace data collection is performed for some further instructions, and then the collection is stopped.

### Requirements

The C-SPY J-Link/J-Trace driver.

### Trigger at

Specify the code location of the breakpoint. Alternatively, click the **Edit** button to open the **Enter Location** dialog box, see *Enter Location dialog box*, page 159.

### Size

Controls the size of the address range where filtered trace is active. Choose between:

#### Auto

Sets the size automatically. This can be useful if **Trigger at** contains a variable.

#### Manual

Specify the size of the breakpoint range manually.

### Trigger range

Shows the requested range and the effective range to be covered by the trace data collection. The range suggested is either within or exactly the area specified by the **Trigger at** and the **Size** options.

#### Extend to cover requested range

Extends the range so that a whole data structure is covered. For data structures that do not fit the size of the possible ranges supplied by the hardware breakpoint unit, for example three bytes, the range will not cover the whole data structure. Note that the range will be extended beyond the size of the data structure, which might cause false triggers at adjacent data.

This option is not enabled for Arm7/9 devices because the range for such devices will always cover the whole data structure.

### Access Type

Selects the type of memory access that triggers the breakpoint:

#### Read/Write

Reads from or writes to location.

#### Read

Reads from location.

#### Write

Writes to location.



**OP-fetch**

Accesses at execution address.

**Cycle**

The number of counter cycles at a specific point in time, counted from where the execution started. This option is only available for Cortex-M devices.

**Match data**

Enables matching of the accessed data. Use the **Match data** options in combination with the Read/Write, Read, or Write access types for data. This option can be useful when you want a trigger when a variable has a certain value.

**Value** Specify a data value.

**Mask** Specify which part of the value to match (word, halfword, or byte).

The **Match data** options are only available for J-Link/J-Trace and when using a Cortex-M device.

**Note:** For Cortex-M devices, only one breakpoint with **Match data** can be set. Such a breakpoint uses two breakpoint resources.

**Link condition**

Specifies how trace conditions are combined, using **AND** and **OR**. When combining a condition that has the link condition **AND** with a condition that has the link condition **OR**, **AND** has precedence. The option **Inverse** inverts the trace condition and is individual for each trace filter condition. If one trace start or stop condition is inverted, all others will be too. An inverted trace start or stop condition means that the trace data collection is performed everywhere except for this section of the application code.

For Arm7/9 devices, trace filters are combined using the OR algorithm. Use the **Inverse** option to invert the trace filter—all trace filters are affected. The trace filter will be combined with the start and stop triggers, if any, using the AND algorithm.

**Find in Trace dialog box**

The **Find in Trace** dialog box is available by clicking the **Find** button on the **Trace** window toolbar or by choosing **Edit>Find and Replace>Find**.

Note that the **Edit>Find and Replace>Find** command is context-dependent. It displays the **Find in Trace** dialog box if the **Trace** window is the current window or the **Find** dialog box if the editor window is the current window.

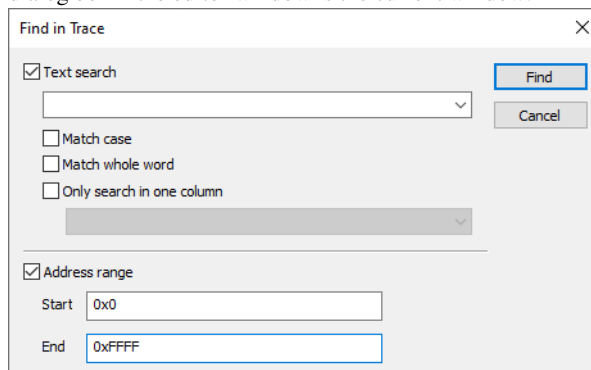

Use this dialog box to specify the search criteria for advanced searches in the trace data.

The search results are displayed in the **Find in Trace** window—available from the **View>Messages** menu, see *Find in Trace window*, page 255.

See also *Searching in trace data*, page 217.

## Requirements

One of these alternatives:

- The C-SPY Simulator. Not available for all cores and devices.
- The C-SPY I-jet driver
- The C-SPY J-Link/J-Trace driver
- The C-SPY CMSIS-DAP driver
- The C-SPY ST-LINK driver
- The C-SPY TI XDS driver

## Text search

Specify the string you want to search for. To specify the search criteria, choose between:

### Match case

Searches only for occurrences that exactly match the case of the specified text. Otherwise **int** will also find **INT**, **Int**, and so on.

### Match whole word

Searches only for the string when it occurs as a separate word. Otherwise **int** will also find **print**, **sprintf**, and so on.

### Only search in one column

Searches only in the column you selected from the drop-down list.

### Address range

Specify the address range you want to display or search. The trace data within the address range is displayed. If you have also specified a text string in the **Text search** field, the text string is searched for within the address range.

## Find in Trace window

The **Find in Trace** window is available from the **View>Messages** menu. Alternatively, it is automatically displayed when you perform a search using the **Find in Trace** dialog box or perform a search using the **Find in Trace** command available from the context menu in the editor window.

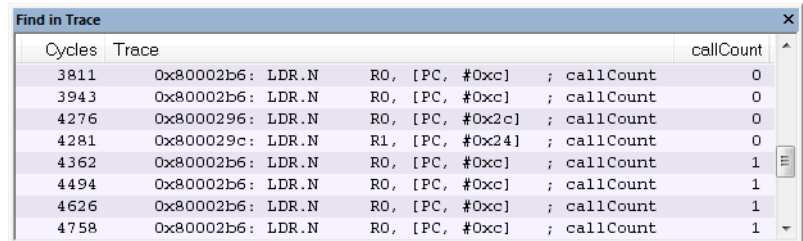

Cycles	Trace	callCount
3811	0x80002b6: LDR.N RO, [PC, #0xc] ; callCount	0
3943	0x80002b6: LDR.N RO, [PC, #0xc] ; callCount	0
4276	0x8000296: LDR.N RO, [PC, #0x2c] ; callCount	0
4281	0x800029c: LDR.N R1, [PC, #0x24] ; callCount	0
4362	0x80002b6: LDR.N RO, [PC, #0xc] ; callCount	1
4494	0x80002b6: LDR.N RO, [PC, #0xc] ; callCount	1
4626	0x80002b6: LDR.N RO, [PC, #0xc] ; callCount	1
4758	0x80002b6: LDR.N RO, [PC, #0xc] ; callCount	1

This window displays the result of searches in the trace data. Double-click an item in the **Find in Trace** window to bring up the same item in the **Trace** window.

Before you can view any trace data, you must specify the search criteria in the **Find in Trace** dialog box, see *Find in Trace dialog box*, page 253.

See also *Searching in trace data*, page 217.

### Requirements

One of these alternatives:

- The C-SPY Simulator. Not available for all cores and devices.
- The C-SPY I-jet driver
- The C-SPY J-Link/J-Trace driver
- The C-SPY CMSIS-DAP driver
- The C-SPY ST-LINK driver

### Display area

The **Find in Trace** window looks like the **Trace** window and shows the same columns and data, but *only* those rows that match the specified search criteria.

## Trace Save dialog box

The **Trace Save** dialog box is available from the driver-specific menu, and from the **Trace** window and the **SWO Trace** window.

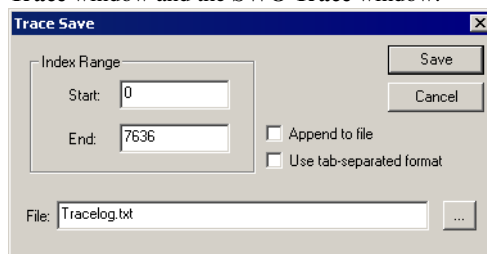

### Requirements

One of these alternatives:

- The C-SPY J-Link/J-Trace driver
- The C-SPY ST-LINK driver
- The C-SPY TI XDS driver

### Index Range

Saves a range of frames to a file. Specify a start index and an end index (as numbered in the index column in the **Trace** window).

### Append to file

Appends the trace data to an existing file.

### Use tab-separated format

Saves the content in columns that are tab-separated, instead of separated by white spaces.

### File

Specify a file for the trace data.

# The application timeline

- Introduction to analyzing your application's timeline
- Analyzing your application's timeline
- Reference information on application timeline

---

## Introduction to analyzing your application's timeline

These topics are covered:

- Briefly about analyzing the timeline
- Requirements for timeline support

See also:

- *Trace*, page 209

### BRIEFLY ABOUT ANALYZING THE TIMELINE

C-SPY can provide information for various aspects of your application, collected when the application is running. This can help you to analyze the application's behavior.

You can view the timeline information in different representations:

- As different *graphs* that correlate with the running application in relation to a shared *time axis*.
- As detailed logs
- As summaries of the logs.

Depending on the capabilities of your hardware, the debug probe, and the C-SPY driver you are using, timeline information can be provided for:

**Call stack** Can be represented in the **Timeline** window, as a graph that displays the sequence of function calls and returns collected by the trace system. You get timing information between the function invocations.

Note that there is also a related **Call Stack** window and a **Function Trace** window, see *Call Stack window*, page 88 and *Function Trace window*, page 238, respectively.

**Data logging** Based on data logs collected by the trace system for up to four different variables or address ranges, specified by means of *Data Log breakpoints*. Choose to display the data logs:

- In the **Timeline** window, as a graph of how the values change over time.
- In the **Data Log** window and the **Data Log Summary** window.

**Event logging** Based on *event logs* produced when the execution passes specific positions in your application code. Choose to display the event logs:

- In the **Timeline** window, as a graph of the timing of the events.
- In the **Event Log** window and the **Event Log Summary** window.

Event logs can help you to analyze the application flow and inspect data correlated to a certain position in your application code.

**Interrupt logging** Based on interrupt logs collected by the trace system. Choose to display the interrupt logs:

- In the **Timeline** window, as a graph of the interrupt events during the execution of your application.
- In the **Interrupt Log** window and the **Interrupt Log Summary** window.

Interrupt logging can, for example, help you locate which interrupts you can fine-tune to make your application more efficient.

For more information, see the chapter *Interrupts*.

**Power logging** Based on logged power measurement samples generated by the debug probe or associated hardware. Choose to display the power logs:

- In the **Timeline** window, as a graph of the power measurement samples.
- In the **Power Log** window.

Power logs can be useful for finding peaks in the power consumption and by double-clicking on a value you can see the corresponding source code. The precision depends on the frequency of the samples, but there is a good chance that you find the source code sequence that caused the peak.

For more information, see the chapter *Power debugging*.

**State logging** Based on logged activity—state changes—for peripheral units and clocks, as well as for CPU modes generated by the debug probe or associated hardware. Choose to display the state logs:

- In the **Timeline** window, as a graph of the state changes.
- In the **State Log** window and in the **State Log Summary** window.

The information is useful for tracing the activity on the target system.

For more information, see the chapter *Power debugging*.

## REQUIREMENTS FOR TIMELINE SUPPORT

Depending on the capabilities of the hardware, the debug probe, and the C-SPY driver you are using, timeline information is supported for:

Target system	Call Stack	Data logging	State logging	Event logging	Interrupt logging	Power logging
C-SPY simulator	Yes <sup>3</sup>	Yes <sup>3</sup>	—	—	Yes <sup>3</sup>	—
CMSIS-DAP	Yes <sup>2</sup>	—	—	—	—	—
I-jet	Yes <sup>2</sup>	Yes	—	Yes	Yes	Yes
J-Link	Yes <sup>2</sup>	Yes	—	Yes	Yes	Yes
J-Trace	Yes	Yes <sup>1</sup>	—	Yes <sup>1</sup>	Yes <sup>1</sup>	—
ST-LINK	—	Yes <sup>3</sup>	—	Yes <sup>3</sup>	Yes <sup>3</sup>	Yes <sup>3</sup>
TI MSP-FET	—	—	Yes	—	—	Yes
TI XDS	—	Yes	Yes	Yes	Yes	Yes

Table 11: Support for timeline information

1 Very limited when ETM trace is enabled.

2 Requires ETB/MTB.

3 Not for all cores and devices.

For more information about requirements related to trace data, see *Requirements for using trace*, page 212.

## Analyzing your application's timeline

These tasks are covered:

- Displaying a graph in the Timeline window
- Navigating in the graphs

- Analyzing performance using the graph data
- Getting started using data logging
- Getting started using event logging

See also:

- *Debugging in the power domain*, page 328
- *Using the interrupt system*, page 406

## DISPLAYING A GRAPH IN THE TIMELINE WINDOW

The **Timeline** window can display several graphs—follow this example procedure to display any of these graphs. For an overview of the graphs and what they display, see *Briefly about analyzing the timeline*, page 257.

- 1 Choose **C-SPY driver>SWO Configuration** to open the **SWO Configuration** dialog box. Make sure the **CPU clock** option is set to the same value as the CPU clock value set by your application. This is necessary to set the SWO clock and to obtain a correct data transfer to the debug probe.

If you are using the C-SPY simulator in **32-bit mode**, choose **Simulator>Simulated Frequency** to set up a frequency that matches the simulated hardware.

- 2 Choose **Timeline** from the C-SPY driver menu to open the **Timeline** window.
- 3 In the **Timeline** window, right-click in the window and choose **Select Graphs** from the context menu to select which graphs to be displayed.
- 4 In the **Timeline** window, right-click in the graph area and choose **Enable** from the context menu to enable a specific graph.
- 5 For the Data Log graph, you must set a Data Log breakpoint for each variable you want a graphical representation of in the **Timeline** window. See *Data Log breakpoints dialog box*, page 151 and *Data Log breakpoints dialog box (C-SPY hardware drivers)*, page 152, respectively.
- 6 For the Event graph, you must add a preprocessor macro to your application source code where you want events to be generated. See *Getting started using event logging*, page 264.
- 7 Click **Go** on the toolbar to start executing your application. The graphs that you have enabled appear.



## NAVIGATING IN THE GRAPHS

After you have performed the steps in *Displaying a graph in the Timeline window*, page 260, you can use any of these alternatives to navigate in the graph:

- Right-click and from the context menu choose **Zoom In** or **Zoom Out**. Alternatively, use the + and – keys. The graph zooms in or out depending on which command you used.
- Right-click in the graph and from the context menu choose **Navigate** and the appropriate command to move backwards and forwards on the graph. Alternatively, use any of the shortcut keys—arrow keys, Home, End, and Ctrl+End.
- Double-click on a sample of interest to highlight the corresponding source code in the editor window and in the **Disassembly** window.
- Click on the graph and drag to select a time interval, which will correlate to the running application. The selection extends vertically over all graphs, but appears highlighted in a darker color for the selected graph. Press Enter or right-click and from the context menu choose **Zoom>Zoom to Selection**. The selection zooms in. Use the navigation keys in combination with the Shift key to extend the selection.

## ANALYZING PERFORMANCE USING THE GRAPH DATA

The **Timeline** window provides a set of tools for analyzing the graph data.

- 1 In the **Timeline** window, right-click and choose **Time Axis Unit** from the context menu. Select which unit to be used on the time axis—choose between **Seconds** and **Cycles**. If **Cycles** is not available, the graphs are based on different clock sources.
- 2 Execute your application to display a graph, following the steps described in *Displaying a graph in the Timeline window*, page 260.
- 3 Whenever execution stops, point at the graph with the mouse pointer to get detailed tooltip information for that location.

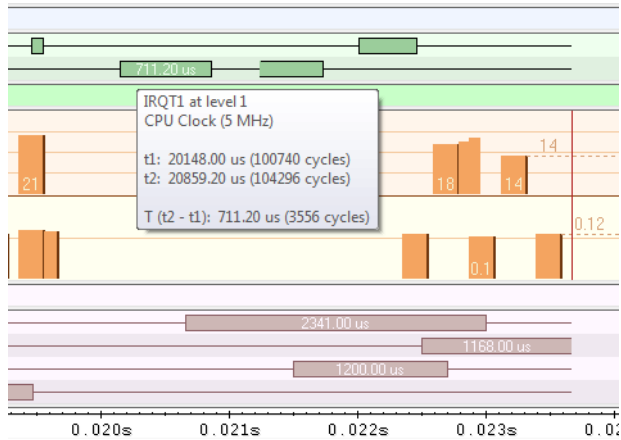

Note that if you have enabled several graphs, you can move the mouse pointer over the different graphs to get graph-specific information.

- 4 Click in the graph and drag to select a time interval. Point in the graph with the mouse pointer to get timing information for the selection.

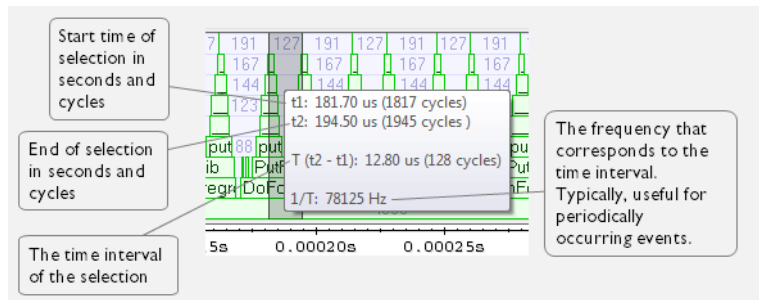

## GETTING STARTED USING DATA LOGGING

- I To set up for data logging, choose *C-SPY driver*>**Configuration**. In the dialog box, set up the serial-wire output communication channel for trace data. Note specifically the **CPU clock** option. You can set a default value for the CPU clock on the **Project>Options>C-SPY driver** page. In the **SWO Configuration** dialog box, you can override the default value.

If you are using the C-SPY simulator you can ignore this step.

- 2 To set a data log breakpoint, use one of these methods:
  - In the **Breakpoints** window, right-click and choose **New Breakpoint>Data Log** to open the breakpoints dialog box. Set a breakpoint on the memory location that you want to collect log information for. This can be specified either as a variable or as an address.
  - In the **Memory** window, select a memory area, right-click and choose **Set Data Log Breakpoint** from the context menu. A breakpoint is set on the start address of the selection.
  - In the editor window, select a variable, right-click and choose **Set Data Log Breakpoint** from the context menu. The breakpoint will be set on the part of the variable that the microcontroller can access using one instruction.

You can set up to four data log breakpoints. For more information, see *Data Log breakpoints*, page 127.

- 3 Choose **C-SPY driver>Data Log** to open the **Data Log** window. Optionally, you can also choose:
  - **C-SPY driver>Data Log Summary** to open the **Data Log Summary** window
  - **C-SPY driver>Timeline** to open the **Timeline** window to view the Data Log graph.
- 4 From the context menu, available in the **Data Log** window, choose **Enable** to enable the logging.
- 5 In the **SWO Configuration** dialog box, you can notice in the Data Log Events area that Data Logs are enabled. Choose which level of logging you want:
  - PC only
  - PC + data value + base address
  - Data value + exact address

If you are using the C-SPY simulator you can ignore this step.

- 6 Start executing your application program to collect the log information.
- 7 To view the data log information, look in the **Data Log** window, the **Data Log Summary** window, or the Data graph in the **Timeline** window.
- 8 If you want to save the log or summary to a file, choose **Save to log file** from the context menu in the window in question.
- 9 To disable data logging, choose **Disable** from the context menu in each window where you have enabled it.

## GETTING STARTED USING EVENT LOGGING

- 1 To specify the position in your application source code that you want to generate events for, use the predefined preprocessor macros in `arm_itm.h` (located in `arm\inc\c`). In your application source code, write (for example):

```
#include <arm_itm.h>
void func(void)
{
    ITM_EVENT8_WITH_PC(1, 25);
    ITM_EVENT32_WITH_PC(2, __get_PSP());
}
```

The first line sends an event with the value 25 to channel 1. The second line sends an event with the current value of the stack pointer to channel 2, which means that C-SPY can display the stack pointer at a code position of your choice. When these source lines are passed during program execution, events will be generated and visualized by C-SPY, which means that you can further analyze them.

- 2 To view event information, you can choose between these alternatives:
  - Choose **C-SPY driver>Timeline** to open the **Timeline** window and choose **Enable** from the context menu. You can now view events for each channel as a graph (Event graph). See also *Timeline window—Events graph*, page 286.
  - Choose **C-SPY driver>Event Log** to open the **Event Log** window and choose **Enable** from the context menu. You can now view the events for each channel as numbers. See also *Event Log window*, page 271.
  - Choose **C-SPY driver>Event Log Summary** to open the **Event Log Summary** window and choose **Enable** from the context menu. You will now get a summary of all events. See also *Event Log Summary window*, page 274.

**Note:** Whenever the Events graph or the **Event Log** window is enabled, you can also enable the **Event Log Summary** window to get a summary. However, if you have enabled the **Event Log Summary** window, but not the **Event Log** window or the Event graph in the **Timeline** window, you can get a summary but not detailed information about events.

- 3 Select the graph and right-click to view the context menu. Here you can choose to:
  - Change the radix (you can choose between displaying values in hexadecimal or in decimal format). Note that this setting affects also the **Event Log** window and the **Event Log Summary** window.
  - Show the numerical value of the variables
  - Show the value of the events
  - Select the style of the graph (as bars, levels, or linear)
  - Select the size of the graph (S, M, or L)

- Go to source
- 4** Start executing your application program to collect the log information.
- 5** To view the event information, look at either the **Event Log** window, the **Event Log Summary** window, or the event graph for the specific channel in the **Timeline** window.
- 6** If you want to save the log or summary to a file, choose **Save to log file** from the context menu in the window.
- 7** To disable event logging, choose **Disable** from the context menu in each window where you have enabled it.

---

## Reference information on application timeline

Reference information about:

- *Timeline window—Call Stack graph*, page 277
- *Timeline window—Data Log graph*, page 282
- *Timeline window—Events graph*, page 286
- *Data Log window*, page 266
- *Data Log Summary window*, page 269
- *Event Log window*, page 271
- *Event Log Summary window*, page 274
- *Viewing Range dialog box*, page 290

See also:

- *Timeline window—Interrupt Log graph*, page 422
- *Timeline window—Power graph*, page 338
- *Timeline window—State Log graph*, page 344

## Data Log window

The **Data Log** window is available from the C-SPY driver menu.

Time	Program Counter	l1	Address	s2	Address
0.160us	---			W 0x0000	@ 0x2004
0.160us	0xFFE00049	-	@ 0x2000		
24.480us	0xFFE000B5			R 0x0000	@ 0x2006
24.720us	0xFFE000BF			W 0x0042	@ 0x2004
24.760us	0xFFE000C6			R 0x0042	@ 0x2006
24.960us	0xFFE000E4	W 0x00004444	@ 0x2000		
78.760us	0xFFE00104			R 0x0042	@ 0x2004+?
79.000us	---			W 0x0084	@ 0x2004
100.800us	0xFFE00104			R 0x0084	@ 0x2006
101.040us	0xFFE0010E			W 0x00C6	@ 0x2004
136.640us	Overflow				
136.880us	0xFFE0010E			-	@ 0x2004

White rows indicate read accesses

Grey rows indicate write accesses

Use this window to log accesses to up to four different memory locations or areas.

**Note:** There is a limit on the number of saved logs. When this limit is exceeded, the oldest entries in the buffer are erased.

See also *Getting started using data logging*, page 262.

### Requirements

One of these alternatives:

- The C-SPY simulator. (Not for all cores and devices.)
- A device and a debug probe with support for SWO.

### Display area

Each row in the display area shows the time, the program counter, and, for every tracked data object, its value and address. All information is cleared on reset. The information is displayed in these columns:

#### Time

For the I-jet in-circuit debugging probe, the time for the data access is based on a dedicated 48-MHz clock.

The time for the data access for the C-SPY J-Link driver, the C-SPY ST-LINK driver, and the simulator, based on the clock frequency. For the C-SPY J-Link driver, the C-SPY ST-LINK driver, and the C-SPY TI XDS driver, this is specified in the **SWO Configuration** dialog box.

If the time is displayed in italics, the target system has not been able to collect a correct time, but instead had to approximate it.

This column is available when you have selected **Show time** from the context menu.

### Cycles

The number of cycles from the start of the execution until the event.

If a cycle is displayed in italics, the target system has not been able to collect a correct time, but instead had to approximate it.

This column is available when you have selected **Show cycles** from the context menu.

### Program Counter\*

Displays one of these:

An address, which is the content of the PC, that is, the address of the instruction that performed the memory access.

---, the target system failed to provide the debugger with any information.

**Overflow** in red, the communication channel failed to transmit all data from the target system.

### Value

Displays the access type and the value (using the access size) for the location or area you want to log accesses to. For example, if zero is read using a byte access it will be displayed as 0x00, and for a long access it will be displayed as 0x00000000.

To specify what data you want to log accesses to, use the **Data Log** breakpoint dialog box. See *Data Log breakpoints*, page 127.

### Address

The actual memory address that is accessed. For example, if only a byte of a word is accessed, only the address of the byte is displayed. The address is calculated as base address + offset, where the base address is retrieved from the **Data Log** breakpoint dialog box and the offset is retrieved from the logs. If the log from the target system does not provide the debugger with an offset, the

offset contains + ?. If you want the offset to be displayed (for the C-SPY I-jet driver, the C-SPY J-Link driver, the C-SPY ST-LINK driver, and the C-SPY TI XDS driver), select the **Value + exact addr** option in the **SWO Configuration** dialog box.

\* You can double-click a line in the display area. If the value of the PC for that line is available in the source code, the editor window displays the corresponding source code (this does not include library source code).

## Context menu

This context menu is available:

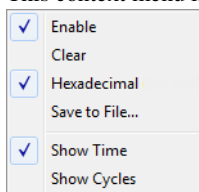

These commands are available:

### Enable

Enables the logging system. The system will log information also when the window is closed.

### Clear

Deletes the log information. Note that this will also happen when you reset the debugger.

### Hexadecimal

Toggles between displaying the selected value in decimal or hexadecimal format. Note that this setting also affects the log window.

### Save to File

Displays a standard file selection dialog box where you can select the destination file for the log information. The entries in the log file are separated by TAB and LF characters. An X in the **Approx** column indicates that the timestamp is an approximation.

### Show Time

Displays the **Time** column. If the **Time** column is displayed by default in the C-SPY driver you are using, this menu command is not available.

### Show Cycles

Displays the **Cycles** column. If the **Cycles** column is not supported in the C-SPY driver you are using, this menu command is not available.



## Data Log Summary window

The **Data Log Summary** window is available from the C-SPY driver menu.

Data	Total Accesses	Read Accesses	Write Accesses	Unknown Accesses
tVar1	42	0	25	17
tVar2	66	17	49	0
tVar3	32	32	0	0

Approximative time count: 16  
 Overflow count: 8  
 Current time: 4301.52 us

This window displays a summary of data accesses to specific memory location or areas.

See also *Getting started using data logging*, page 262.

### Requirements

One of these alternatives:

- The C-SPY simulator. (Not for all cores and devices.)
- A device and a debug probe with support for SWO.

### Display area

Each row in this area displays the type and the number of accesses to each memory location or area in these columns. Summary information is listed at the bottom of the display area.

#### Data

The name of the data object you have selected to log accesses to. To specify what data object you want to log accesses to, use the **Data Log** breakpoint dialog box. See *Data Log breakpoints*, page 127.

#### Total Accesses

The total number of accesses.

If the sum of read accesses and write accesses is less than the total accesses, the target system for some reason did not provide valid access type information for all accesses.

#### Read Accesses

The total number of read accesses.

#### Write Accesses

The total number of write accesses.

### Unknown Accesses

The number of unknown accesses, in other words, accesses where the access type is not known.

### Approximative time count

The information displayed depends on the C-SPY driver you are using.

For some C-SPY drivers, this information is not displayed or the value is always zero. In this case, all logs have an exact time stamp.

For other C-SPY drivers, a non-zero value is displayed. The value represents the amount of logs with an approximative time stamp. This might happen if the bandwidth in the communication channel is too low compared to the amount of data packets generated by the CPU or if the CPU generated packets with an approximative time stamp.

### Overflow count

The information displayed depends on the C-SPY driver you are using.

For some C-SPY drivers, this information is not displayed or the value is always zero.

For other C-SPY drivers, the number represents the amount of overflows in the communication channel which can cause logs to be lost. If this happens, it indicates that logs might be incomplete. To solve this, make sure not to use all C-SPY log features simultaneously or check used bandwidth for the communication channel.

### Current time/Current cycles

The information displayed depends on the C-SPY driver you are using.

For some C-SPY drivers, the value is always zero or not visible at all.

For other C-SPY drivers, the number represents the current time or cycles—the number of cycles or the execution time since the start of execution.

### Context menu

This context menu is available:

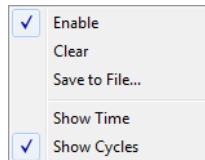

These commands are available:

#### Enable

Enables the logging system. The system will log information also when the window is closed.

#### Clear

Deletes the log information. Note that this will also happen when you reset the debugger.

#### Save to File

Displays a standard file selection dialog box where you can select the destination file for the log information. The entries in the log file are separated by `TAB` and `LF` characters. An **X** in the **Approx** column indicates that the timestamp is an approximation.

#### Show Time

Displays the **Time** column. If the **Time** column is displayed by default in the C-SPY driver you are using, this menu command is not available.

#### Show Cycles

Displays the **Cycles** column. If the **Cycles** column is not supported in the C-SPY driver you are using, this menu command is not available.

## Event Log window

The **Event Log** window is available from the C-SPY driver menu.

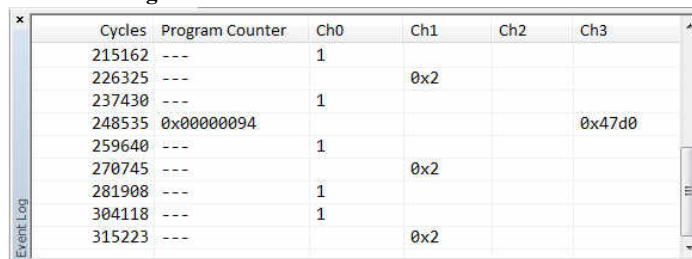

Cycles	Program Counter	Ch0	Ch1	Ch2	Ch3
215162	---	1			
226325	---		0x2		
237430	---	1			
248535	0x00000094				0x47d0
259640	---	1			
270745	---		0x2		
281908	---	1			
304118	---	1			
315223	---		0x2		

This window displays the events produced when the execution passes specific positions in your application code. The Cortex ITM communication channels are used for passing the events from a running application to the C-SPY Events system.

**Note:** There is a limit on the number of saved logs. When this limit is exceeded, the oldest entries in the buffer are erased.

See also *Getting started using event logging*, page 264.

## Requirements

A Cortex device and one of these alternatives:

- The C-SPY I-jet driver and an I-jet or I-jet Trace in-circuit debugging probe with an SWD interface between the debug probe and the target system
- The C-SPY J-Link/J-Trace driver and a J-Link or J-Trace debug probe with an SWD interface between the debug probe and the target system
- The C-SPY ST-LINK driver and an ST-LINK debug probe with an SWD interface between the debug probe and the target system
- The C-SPY TI XDS driver and a TI XDS debug probe with an SWD interface between the debug probe and the target system.

## Display area

Each row in the display area shows the events in these columns:

### Cycles

The number of cycles from the start of the execution until the event. This information is cleared at reset.

If a cycle is displayed in italics, the target system has not been able to collect a correct time, but instead had to approximate it.

This column is available when you have selected **Show cycles** from the context menu.

### Program Counter

An address, which is the content of the PC, that is, the address of the instruction that performed the memory access.

---, the target system failed to provide the debugger with any information.

**Overflow** in red, the communication channel failed to transmit all data from the target system.

### ITM1

### ITM2

### ITM3

### ITM4

The Cortex ITM communication channels for which the events are logged. For each event, the event value is displayed.

Add a preprocessor macro to your application source code where you want events to be generated. See *Getting started using event logging*, page 264.

## Context menu

This context menu is available:

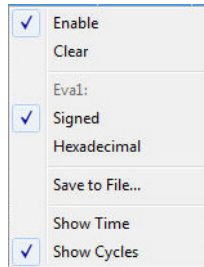

These commands are available:

### Enable

Enables the logging system. The system will log information also when the window is closed.

### Clear

Deletes the log information. Note that this will also happen when you reset the debugger.

### *Variable*

The name of the channel for which the Events-specific commands below apply. This menu command is context-sensitive, which means it reflects the channel in the Events graph you selected in the **Timeline** window (one of up to four).

### Signed

Toggles between displaying the selected value as a signed or unsigned number. Note that this setting also affects the log window.

### Hexadecimal

Toggles between displaying the selected value in decimal or hexadecimal format. Note that this setting also affects the log window.

### Save to File

Displays a standard file selection dialog box where you can select the destination file for the log information. The entries in the log file are separated by `TAB` and `LF` characters. An **X** in the **Approx** column indicates that the timestamp is an approximation.

### Show Time

Displays the **Time** column. If the **Time** column is displayed by default in the C-SPY driver you are using, this menu command is not available.

### Show Cycles

Displays the **Cycles** column. If the **Cycles** column is not supported in the C-SPY driver you are using, this menu command is not available.

## Event Log Summary window

The **Event Log Summary** window is available from the C-SPY driver menu.

Channel	Count	Average Value	Min Value	Max Value	Average Interval	Min Interval	Max Interval
Ch0	13	1	1	1	506.720us	444.200us	1189.980us
Ch1	7	0x2	0x2	0x2	889.360us	888.400us	889.620us
Ch2	0						
Ch3	1	0x47d0	0x47d0	0x47d0			

Approximative time count: 0  
 Overflow count: 0  
 Current time: 6507.580us

This window displays a summary of events produced when the execution passes specific positions in your application code. The Cortex ITM communication channels are used for passing the events from a running application to the C-SPY Event system.

See also *Getting started using event logging*, page 264.

### Requirements

A Cortex device and one of these alternatives:

- The C-SPY I-jet driver and an I-jet or I-jet Trace in-circuit debugging probe with an SWD interface between the debug probe and the target system
- The C-SPY J-Link/J-Trace driver and a J-Link or J-Trace debug probe with an SWD interface between the debug probe and the target system
- The C-SPY ST-LINK driver and an ST-LINK debug probe with an SWD interface between the debug probe and the target system
- The C-SPY TI XDS driver and a TI XDS debug probe with an SWD interface between the debug probe and the target system.

### Display area

Each row displays the type and the number of accesses to each location in your application code in these columns. Summary information is listed at the bottom of the display area.

#### Channel

The name of the communication channel for which events are generated.

**Count**

The number of logged events.

**Average Value**

The average value of all received event values.

**Min Value**

The smallest value of all received event values.

**Max Value**

The largest value of all received event values.

**Average Interval**

The average time (in cycles) between events.

**Min Interval**

The shortest time (in cycles) between two events.

**Max Interval**

The longest time (in cycles) between two events.

**Approximative time count**

The information displayed depends on the C-SPY driver you are using.

For some C-SPY drivers, this information is not displayed or the value is always zero. In this case, all logs have an exact time stamp.

For other C-SPY drivers, a non-zero value is displayed. The value represents the amount of logs with an approximative time stamp. This might happen if the bandwidth in the communication channel is too low compared to the amount of data packets generated by the CPU or if the CPU generated packets with an approximative time stamp.

**Overflow count**

The information displayed depends on the C-SPY driver you are using.

For some C-SPY drivers, this information is not displayed or the value is always zero.

For other C-SPY drivers, the number represents the amount of overflows in the communication channel which can cause logs to be lost. If this happens, it indicates that logs might be incomplete. To solve this, make sure not to use all C-SPY log features simultaneously or check used bandwidth for the communication channel.

**Current time/Current cycles**

The information displayed depends on the C-SPY driver you are using.

For some C-SPY drivers, the value is always zero or not visible at all.

For other C-SPY drivers, the number represents the current time or cycles—the number of cycles or the execution time since the start of execution.

## Context menu

This context menu is available:

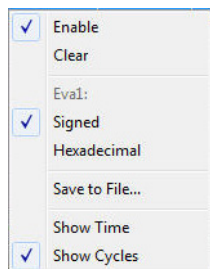

These commands are available:

### Enable

Enables the logging system. The system will log information also when the window is closed.

### Clear

Deletes the log information. Note that this will also happen when you reset the debugger.

### *Variable*

The name of the channel for which the Events-specific commands below apply. This menu command is context-sensitive, which means it reflects the channel in the Events graph you selected in the **Timeline** window (one of up to four).

### Signed

Toggles between displaying the selected value as a signed or unsigned number. Note that this setting also affects the log window.

### Hexadecimal

Toggles between displaying the selected value in decimal or hexadecimal format. Note that this setting also affects the log window.

### Save to File

Displays a standard file selection dialog box where you can select the destination file for the log information. The entries in the log file are separated by TAB and LF characters. An X in the **Approx** column indicates that the timestamp is an approximation.



### Show Time

Displays the **Time** column. If the **Time** column is displayed by default in the C-SPY driver you are using, this menu command is not available.

### Show Cycles

Displays the **Cycles** column. If the **Cycles** column is not supported in the C-SPY driver you are using, this menu command is not available.

## Timeline window—Call Stack graph

The **Timeline** window is available from the *C-SPY driver* menu during a debug session.

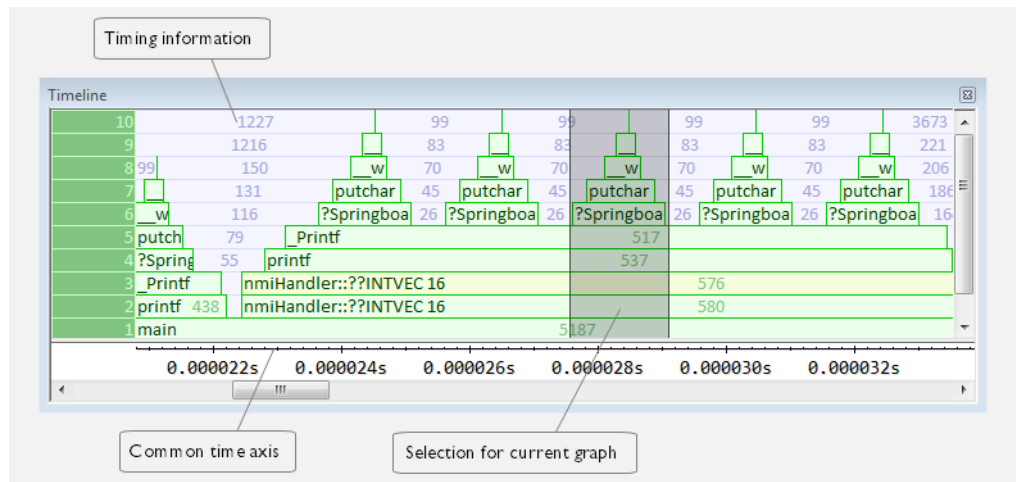

This window displays trace data represented as different graphs, in relation to a shared time axis.

The Call Stack graph displays the sequence of function calls and returns collected by the trace system.

**Note:** There is a limit on the number of saved logs. When this limit is exceeded, the oldest entries in the buffer are erased.

### Requirements

One of these alternatives:

- The C-SPY simulator. (Not for all cores and devices.)
- ETB/ETM and one of the C-SPY CMSIS-DAP driver, the C-SPY I-jet driver, or the C-SPY J-Link/J-Trace driver

- The C-SPY I-jet driver and an I-jet Trace debug probe
- The C-SPY J-Link/J-Trace driver and a J-Trace debug probe

### Display area for the Call Stack graph

Each function invocation is displayed as a horizontal bar which extends from the time of entry until the return. Called functions are displayed above its caller. The horizontal bars use four different colors:

- Medium green for normal C functions with debug information
- Light green for functions known to the debugger through an assembler label
- Medium yellow for normal interrupt handlers, with debug information
- Light yellow for interrupt handlers known to the debugger through an assembler label

The timing information represents the number of cycles spent in, or between, the function invocations.

At the bottom of the window, there is a shared time axis that uses seconds or cycles as the time unit.

Click in the graph to display the corresponding source code.

**Note:** For highly optimized code, C-SPY might not be able to identify all calls. This means that for highly optimized code, the call stack is not entirely trustworthy.

### Context menu

This context menu is available:

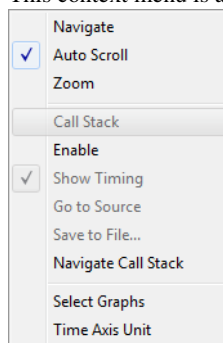

**Note:** The contents of this menu are dynamic and depend on which features that your combination of software and hardware supports. However, the list of menu commands below is complete and covers all possible commands.

These commands are available:

### Navigate

Commands for navigating the graph(s). Choose between:

**Next** moves the selection to the next relevant point in the graph. Shortcut key: right arrow.

**Previous** moves the selection backward to the previous relevant point in the graph. Shortcut key: left arrow.

**First** moves the selection to the first data entry in the graph. Shortcut key: Home.

**Last** moves the selection to the last data entry in the graph. Shortcut key: End.

**End** moves the selection to the last data in any displayed graph, in other words the end of the time axis. Shortcut key: Ctrl+End.

### Auto Scroll

Toggles automatic scrolling on or off. When on, the most recently collected data is automatically displayed when you choose **Navigate>End**.

### Zoom

Commands for zooming the window, in other words, changing the time scale. Choose between:

**Zoom to Selection** makes the current selection fit the window. Shortcut key: Return.

**Zoom In** zooms in on the time scale. Shortcut key: +

**Zoom Out** zooms out on the time scale. Shortcut key: –

**10ns, 100ns, 1us**, etc makes an interval of 10 nanoseconds, 100 nanoseconds, 1 microsecond, respectively, fit the window.

**1ms, 10ms**, etc makes an interval of 1 millisecond or 10 milliseconds, respectively, fit the window.

**10m, 1h**, etc makes an interval of 10 minutes or 1 hour, respectively, fit the window.

### Call Stack

A heading that shows that the Call stack-specific commands below are available.

### Enable

Toggles the display of the graph on or off. If you disable a graph, that graph will be indicated as **OFF** in the window. If no data has been collected for a graph, **no data** will appear instead of the graph.

### **Show Timing**

Toggles the display of the timing information on or off.

### **Go To Source**

Displays the corresponding source code in an editor window, if applicable.

### **Save to File**

Saves all contents (or the selected contents) of the Call Stack graph to a file. The menu command is only available when C-SPY is not running.

### **Navigate Call Stack>After Current Loop (L)**

Identifies the selected program counter and scans the trace data forward, collecting program counters, until it finds the same address again. It has now detected a loop. (Loops longer than 1000 instructions are not detected.) Then it navigates forward until it finds a program counter that is not part of the collected set. This is useful for navigating out of many iterations of an idle or polling loop.

### **Navigate Call Stack>Before Current Loop (Shift+L)**

Behaves as **After Current Loop**, but navigates backward out of the loop.

### **Navigate Call Stack>After Current Function (U)**

Navigates to the next unmatched return instruction. This is similar to stepping out of the current function.

### **Navigate Call Stack>Before Current Function (Shift+U)**

Navigates to the closest previous unmatched call instruction.

### **Navigate Call Stack>Next Statement (S)**

Navigates to the next instruction that belongs to a different C statement than the starting point. It skips function calls, i.e. it tries to reach the next statement in the starting frame.

### **Navigate Call Stack>Previous Statement (Shift+S)**

Behaves as **Next statement**, but navigates backward to the closest previous different C statement.

### **Navigate Call Stack>Next on Same Address (A)**

Navigates to the next instance of the starting program counter address, typically to the next iteration of a loop.

### **Navigate Call Stack>Previous on Same Address (Shift+A)**

Navigates to the closest previous instance of the starting program counter address.

**Navigate Call Stack>Next Interrupt (I)**

Navigates to the next interrupt entry. (To then find the matching interrupt exit, follow up with **After Current Function**.)

**Navigate Call Stack>Previous Interrupt (Shift+I)**

Navigates to the closest previous interrupt entry.

**Navigate Call Stack>Next Execution Start Point (E)**

Navigates to the next point where the CPU was started, for example places where the application stopped at breakpoints, or was stepped.

**Navigate Call Stack>Previous Execution Start Point (Shift+E)**

Navigates to the closest previous point where the CPU was started.

**Navigate Call Stack>Next Discontinuity (D)**

Navigates to the next discontinuity in the trace data.

**Navigate Call Stack>Previous Discontinuity (Shift+D)**

Navigates to the closest previous discontinuity in the trace data.

**Select Graphs**

Selects which graphs to be displayed in the **Timeline** window.

**Time Axis Unit**

Selects the unit used in the time axis—choose between **Seconds** and **Cycles**.

If **Cycles** is not available, the graphs are based on different clock sources. In that case you can view cycle values as tooltip information by pointing at the graph with your mouse pointer.

**Profile Selection**

Enables profiling time intervals in the **Function Profiler** window. Note that this command is only available if the C-SPY driver supports PC Sampling. See *Selecting a time interval for profiling information*, page 299.

## Timeline window—Data Log graph

The **Timeline** window is available from the C-SPY driver menu during a debug session.

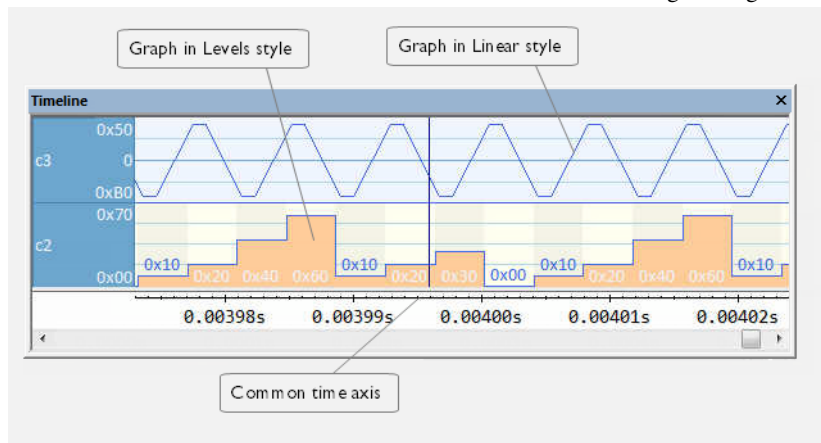

This window displays trace data represented as different graphs, in relation to a shared time axis.

The Data Log graph displays the data logs collected by the trace system, for up to four different variables or address ranges specified as Data Log breakpoints.

**Note:** There is a limit on the number of saved logs. When this limit is exceeded, the oldest entries in the buffer are erased.

### Requirements

One of these alternatives:

- The C-SPY simulator. (Not for all cores and devices.)
- A device and a debug probe with support for SWO.

### Display area for the Data Log graph

Where:

- The label area at the left end of the graph displays the variable name or the address for which you have specified the Data Log breakpoint.
- The graph itself displays how the value of the variable changes over time. The label area also displays the limits, or range, of the Y-axis for a variable. You can use the context menu to change these limits. The graph is a graphical representation of the information in the **Data Log** window, see *Data Log window*, page 266.

- The graph can be displayed either as a thin line between consecutive logs or as a rectangle for every log (optionally color-filled).
- A red vertical line indicates overflow, which means that the communication channel failed to transmit all data logs from the target system. A red question mark indicates a log without a value.

At the bottom of the window, there is a shared time axis that uses seconds or cycles as the time unit.

## Context menu

This context menu is available:

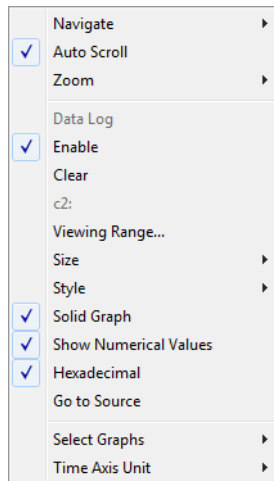

**Note:** The contents of this menu are dynamic and depend on which features that your combination of software and hardware supports. However, the list of menu commands below is complete and covers all possible commands.

These commands are available:

### Navigate

Commands for navigating the graph(s). Choose between:

**Next** moves the selection to the next relevant point in the graph. Shortcut key: right arrow.

**Previous** moves the selection backward to the previous relevant point in the graph. Shortcut key: left arrow.

**First** moves the selection to the first data entry in the graph. Shortcut key: Home.

**Last** moves the selection to the last data entry in the graph. Shortcut key: End.

**End** moves the selection to the last data in any displayed graph, in other words the end of the time axis. Shortcut key: Ctrl+End.

### **Auto Scroll**

Toggles automatic scrolling on or off. When on, the most recently collected data is automatically displayed when you choose **Navigate>End**.

### **Zoom**

Commands for zooming the window, in other words, changing the time scale. Choose between:

**Zoom to Selection** makes the current selection fit the window. Shortcut key: Return.

**Zoom In** zooms in on the time scale. Shortcut key: +

**Zoom Out** zooms out on the time scale. Shortcut key: –

**10ns, 100ns, 1us**, etc makes an interval of 10 nanoseconds, 100 nanoseconds, 1 microsecond, respectively, fit the window.

**1ms, 10ms**, etc makes an interval of 1 millisecond or 10 milliseconds, respectively, fit the window.

**10m, 1h**, etc makes an interval of 10 minutes or 1 hour, respectively, fit the window.

### **Data Log**

A heading that shows that the Data Log-specific commands below are available.

### **Enable**

Toggles the display of the graph on or off. If you disable a graph, that graph will be indicated as **OFF** in the window. If no data has been collected for a graph, **no data** will appear instead of the graph.

### **Clear**

Deletes the log information. Note that this will also happen when you reset the debugger.

### **Variable**

The name of the variable for which the Data Log-specific commands below apply. This menu command is context-sensitive, which means it reflects the Data Log graph you selected in the **Timeline** window (one of up to four).

### **Viewing Range**

Displays a dialog box, see *Viewing Range dialog box*, page 290.



**Size**

Determines the vertical size of the graph—choose between **Small**, **Medium**, and **Large**.

**Style**

Selects the style of the graph. Choose between:

**Bars**, displays a vertical bar for each log.

**Columns**, displays a column for each log.

**Levels**, displays the graph with a rectangle for each log, optionally color-filled.

**Linear**, displays the graph as a thin line between consecutive logs.

Note that all styles are not available for all graphs.

**Solid Graph**

Displays the graph as a color-filled solid graph instead of as a thin line.

**Show Numerical Value**

Shows the numerical value of the variable, in addition to the graph.

**Hexadecimal**

Toggles between displaying the selected value in decimal or hexadecimal format. Note that this setting also affects the log window.

**Go To Source**

Displays the corresponding source code in an editor window, if applicable.

**Select Graphs**

Selects which graphs to be displayed in the **Timeline** window.

**Time Axis Unit**

Selects the unit used in the time axis—choose between **Seconds** and **Cycles**.

If **Cycles** is not available, the graphs are based on different clock sources. In that case you can view cycle values as tooltip information by pointing at the graph with your mouse pointer.

## Timeline window—Events graph

The **Timeline** window is available from the C-SPY driver menu during a debug session.

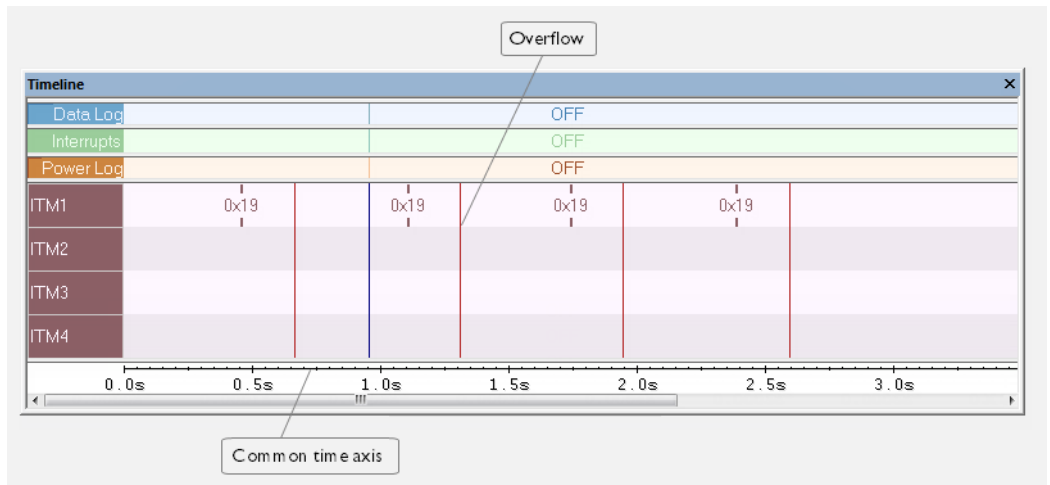

This window displays trace data represented as different graphs, in relation to a shared time axis.

The Events graph displays the events produced when the execution passes specific positions in your application code.

**Note:** There is a limit on the number of saved logs. When this limit is exceeded, the oldest entries in the buffer are erased.

### Requirements

One of these alternatives:

- The C-SPY I-jet driver and an I-jet debug probe
- The C-SPY J-Link/J-Trace driver. For the J-Trace debug probe, event logging is very limited when ETM trace is enabled.
- The C-SPY ST-LINK driver
- The C-SPY TI XDS driver

### Display area for the Events graph

Where:

- The label area at the left end of the graph displays the name of the channel.

- For each channel, there will be a vertical line that indicates when the event occurred. Optionally, you can choose to display the event value that was passed with the event.
- The graph can be displayed in different styles—as a thin line between consecutive logs, as a rectangle for every log (optionally color-filled), or as vertical bars.
- A red vertical line indicates overflow, which means that the communication channel failed to transmit all data logs from the target system.

At the bottom of the window, there is a shared time axis that uses seconds or cycles as the time unit.

See also *Getting started using event logging*, page 264.

## Context menu

This context menu is available:

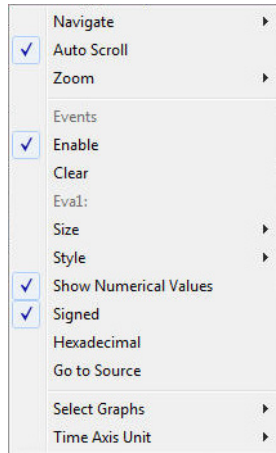

These commands are available:

### Navigate

Commands for navigating the graph(s). Choose between:

**Next** moves the selection to the next relevant point in the graph. Shortcut key: right arrow.

**Previous** moves the selection backward to the previous relevant point in the graph. Shortcut key: left arrow.

**First** moves the selection to the first data entry in the graph. Shortcut key: Home.

**Last** moves the selection to the last data entry in the graph. Shortcut key: End.

**End** moves the selection to the last data in any displayed graph, in other words the end of the time axis. Shortcut key: Ctrl+End.

### **Auto Scroll**

Toggles automatic scrolling on or off. When on, the most recently collected data is automatically displayed when you choose **Navigate>End**.

### **Zoom**

Commands for zooming the window, in other words, changing the time scale. Choose between:

**Zoom to Selection** makes the current selection fit the window. Shortcut key: Return.

**Zoom In** zooms in on the time scale. Shortcut key: +

**Zoom Out** zooms out on the time scale. Shortcut key: –

**10ns, 100ns, 1us**, etc makes an interval of 10 nanoseconds, 100 nanoseconds, 1 microsecond, respectively, fit the window.

**1ms, 10ms**, etc makes an interval of 1 millisecond or 10 milliseconds, respectively, fit the window.

**10m, 1h**, etc makes an interval of 10 minutes or 1 hour, respectively, fit the window.

### **Events**

A heading that shows that the Events-specific commands below are available.

### **Enable**

Toggles the display of the graph on or off. If you disable a graph, that graph will be indicated as **OFF** in the window. If no data has been collected for a graph, **no data** will appear instead of the graph.

### **Clear**

Deletes the log information. Note that this will also happen when you reset the debugger.

### **Variable**

The name of the channel for which the Events-specific commands below apply. This menu command is context-sensitive, which means it reflects the channel in the Events graph you selected in the **Timeline** window (one of up to four).

### **Viewing Range**

Displays a dialog box, see *Viewing Range dialog box*, page 290.

**Size**

Determines the vertical size of the graph—choose between **Small**, **Medium**, and **Large**.

**Style**

Selects the style of the graph. Choose between:

**Bars**, displays a vertical bar for each log.

**Columns**, displays a column for each log.

**Levels**, displays the graph with a rectangle for each log, optionally color-filled.

**Linear**, displays the graph as a thin line between consecutive logs.

Note that all styles are not available for all graphs.

**Show Numerical Value**

Shows the numerical value of the variable, in addition to the graph.

**Signed**

Toggles between displaying the selected value as a signed or unsigned number. Note that this setting also affects the log window.

**Hexadecimal**

Toggles between displaying the selected value in decimal or hexadecimal format. Note that this setting also affects the log window.

**Go To Source**

Displays the corresponding source code in an editor window, if applicable.

**Select Graphs**

Selects which graphs to be displayed in the **Timeline** window.

**Time Axis Unit**

Selects the unit used in the time axis—choose between **Seconds** and **Cycles**.

If **Cycles** is not available, the graphs are based on different clock sources. In that case you can view cycle values as tooltip information by pointing at the graph with your mouse pointer.

## Viewing Range dialog box

The **Viewing Range** dialog box is available from the context menu that appears when you right-click in any graph in the **Timeline** window that uses the linear, levels or columns style.

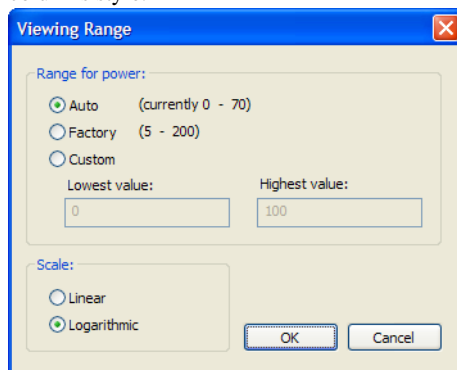

Use this dialog box to specify the value range, that is, the range for the Y-axis for the graph.

### Requirements

One of these alternatives:

- The C-SPY Simulator. (Not for all cores and devices.)
- The C-SPY I-jet driver
- The C-SPY J-Link/J-Trace driver
- The C-SPY ST-LINK driver
- The C-SPY TI XDS driver

### Range for ...

Selects the viewing range for the displayed values:

#### Auto

Uses the range according to the range of the values that are actually collected, continuously keeping track of minimum or maximum values. The currently computed range, if any, is displayed in parentheses. The range is rounded to reasonably *even* limits.

#### Factory

For the Power Log graph—Uses the range according to the properties of the measuring hardware (only if supported by the product edition you are using).

For all other graphs—Uses the range according to the value range of the variable, for example 0–65535 for an unsigned 16-bit integer.

**Custom**

Use the text boxes to specify an explicit range.

**Scale**

Selects the scale type of the Y-axis:

- **Linear**
- **Logarithmic**





# Profiling

- Introduction to the profiler
- Using the profiler
- Reference information on the profiler

---

## Introduction to the profiler

These topics are covered:

- Reasons for using the profiler
- Briefly about the profiler
- Requirements for using the profiler

### REASONS FOR USING THE PROFILER

*Function profiling* can help you find the functions in your source code where the most time is spent during execution. You should focus on those functions when optimizing your code. A simple method of optimizing a function is to compile it using speed optimization. Alternatively, you can move the data used by the function into more efficient memory. For detailed information about efficient memory usage, see the *IAR C/C++ Development Guide for Arm*.

Alternatively, you can use *filtered profiling*, which means that you can exclude, for example, individual functions from being profiled. To profile only a specific part of your code, you can select a *time interval*—using the **Timeline** window—for which C-SPY produces profiling information.

*Instruction profiling* can help you fine-tune your code on a very detailed level, especially for assembler source code. Instruction profiling can also help you to understand where your compiled C/C++ source code spends most of its time, and perhaps give insight into how to rewrite it for better performance.

### BRIEFLY ABOUT THE PROFILER

*Function profiling* information is displayed in the **Function Profiler** window, that is, timing information for the functions in an application. Profiling must be turned on explicitly using a button on the window's toolbar, and will stay enabled until it is turned off.

For debug probes that support it, C-SPY can capture full instruction trace in real time, and process the information for the **Function Profiler** window.

*Instruction profiling* information is displayed in the **Disassembly** window, that is, the number of times each instruction has been executed.

### Profiling sources

The profiler can use different mechanisms, or *sources*, to collect profiling information. Depending on the available trace source features, one or more of the sources can be used for profiling:

- *Trace (calls)*

The full instruction trace (ETM trace) is analyzed to determine all function calls and returns. When the collected instruction sequence is incomplete or discontinuous, as sometimes happens when using ETM trace, the profiling information is less accurate.

Select this profiling source (or Trace (flat)) to activate ETM trace for code coverage.

- *Trace (flat)/Sampling*

Each instruction in the full instruction trace (ETM trace) or each PC Sample (from SWO trace) is assigned to a corresponding function or code fragment, without regard to function calls or returns. This is most useful when the application does not exhibit normal call/return sequences, such as when you are using an RTOS, or when you are profiling code which does not have full debug information.

Select this profiling source (or Trace (calls)) to activate ETM trace for code coverage.

### Power sampling

Some debug probes support sampling of the power consumption of the development board, or components on the board. Each sample is associated with a PC sample and represents the power consumption (actually, the electrical current) for a small time interval preceding the time of the sample. When the profiler is set to use *Power Sampling*, additional columns are displayed in the **Profiler** window. Each power sample is associated with a function or code fragment, just as with regular PC Sampling.

Note that this does not imply that all the energy corresponding to a sample can be attributed to that function or code fragment. The time scales of power samples and instruction execution are vastly different—during one power measurement, the CPU has typically executed many thousands of instructions. Power Sampling is a statistics tool.

## REQUIREMENTS FOR USING THE PROFILER

The C-SPY simulator supports the profiler for most cores and devices. If supported, there are no further specific requirements.

To use the profiler in your hardware debugger system, you need one of these alternatives:

- An I-jet or I-jet Trace in-circuit debugging probe, a J-Link, a J-Trace, ST-LINK debug probe with an SWD/SWO interface between the probe and the target system, which must be based on a Cortex-M device
- A I-jet Trace in-circuit debugging probe and an Arm device with ETM trace
- A J-Trace debug probe and an Arm7/9 or Cortex-M device with ETM trace.

This table lists the C-SPY driver profiling support:

Target system	Trace (calls)	Trace (flat)	Sampling	Power
C-SPY simulator	Yes <sup>4</sup>	Yes <sup>4</sup>	—	—
CMSIS-DAP	Yes	Yes	—	—
I-jet	Yes	Yes	Yes <sup>1</sup>	Yes
I-jet Trace	Yes	Yes	Yes <sup>1</sup>	Yes
J-Link	Yes	Yes	Yes <sup>1</sup>	—
J-Link Ultra	Yes	Yes	Yes <sup>1</sup>	Yes <sup>2</sup>
J-Trace	Yes	Yes	Yes <sup>1</sup>	—
GDB Server	—	—	—	—
ST-LINK	—	—	Yes <sup>1</sup>	Yes <sup>1</sup>
TI Stellaris	—	—	—	—
TI XDS	—	—	Yes <sup>1</sup>	Yes <sup>3</sup>
TI MSP-FET	—	—	—	Yes

Table 12: C-SPY driver profiling support

1 Only for Cortex-M devices supporting SWO.

2 Requires SWO trace.

3 Only for XDS110 with EnergyTrace™ options.

4 Not for all cores and devices.

## Using the profiler

These tasks are covered:

- Getting started using the profiler on function level
- Analyzing the profiling data
- Getting started using the profiler on instruction level

- Selecting a time interval for profiling information



## GETTING STARTED USING THE PROFILER ON FUNCTION LEVEL

To display function profiling information in the **Function Profiler** window:

- 1 Build your application using these options:

Category	Setting
C/C++ Compiler	Output>Generate debug information
Linker	Output>Include debug information in output

Table 13: Project options for enabling the profiler

- 2 To set up the profiler for function profiling:
  - If you use ETM trace, make sure that the **Cycle accurate tracing** option is selected in the **Trace Settings** dialog box.
  - If you use the SWD/SWO interface, no specific settings are required.
- 3  When you have built your application and started C-SPY, choose **C-SPY driver>Function Profiler** to open the **Function Profiler** window, and click the **Enable** button to turn on the profiler. Alternatively, choose **Enable** from the context menu that is available when you right-click in the **Function Profiler** window.
- 4 Start executing your application to collect the profiling information.
- 5 Profiling information is displayed in the **Function Profiler** window. To sort, click on the relevant column header.
- 6  When you start a new sampling, you can click the **Clear** button—alternatively, use the context menu—to clear the data.

## ANALYZING THE PROFILING DATA

Here follow some examples of how to analyze the data.

The first figure shows the result of profiling using **Source: Trace (calls)**. The profiler follows the program flow and detects function entries and exits.

- For the **InitFib** function, **Flat Time** 231 is the time spent inside the function itself.
- For the **InitFib** function, **Acc Time** 487 is the time spent inside the function itself, including all functions **InitFib** calls.
- For the **InitFib/GetFib** function, **Acc Time** 256 is the time spent inside **GetFib** (but only when called from **InitFib**), including any functions **GetFib** calls.

- Further down in the data, you can find the **GetFib** function separately and see all of its subfunctions (in this case none).

Function	Calls	Flat Time	Flat Time (%)	Acc. Time	Acc. Time (%)
main	1	165	3.58	4356	94.39
DoForegroundProcess	10			3704	
InitFib	1			487	
PutFib	10	3174	68.78	3174	68.78
NextCounter	10	100	2.17	100	2.17
InitFib	1	231	5.01	487	10.55
GetFib	16			256	
GetFib	26	416	9.01	416	9.01
DoForegroundProcess	10	270	5.85	3704	80.26
GetFib	10			160	
NextCounter	10				
PutFib	10				
<Other>	0	25			98.85
main	1				

The second figure shows the result of profiling using **Source: Trace (flat)**. In this case, the profiler does not follow the program flow, instead the profiler only detects whether the PC address is within the function scope. For incomplete trace data, the data might contain minor errors.

For the **InitFib** function, **Flat Time** 231 is the time (number of hits) spent inside the function itself.

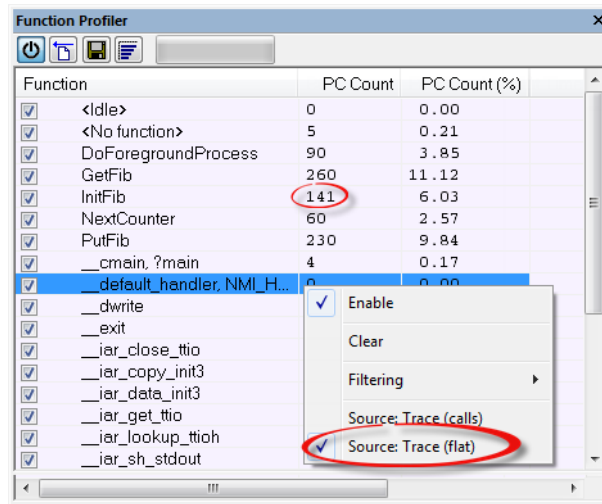

To secure valid data when using a debug probe, make sure to use the maximum trace buffer size and set a breakpoint in your code to stop the execution before the buffer is full.

**Note:** The <No function> entry represents PC values that are not within the known C-SPY ranges for the application.

## GETTING STARTED USING THE PROFILER ON INSTRUCTION LEVEL

To display instruction profiling information in the Disassembly window:

- 1 When you have built your application and started C-SPY, choose **View>Disassembly** to open the **Disassembly** window, and choose **Instruction Profiling>Enable** from the context menu that is available when you right-click in the left-hand margin of the **Disassembly** window.
- 2 Make sure that the **Show** command on the context menu is selected, to display the profiling information.
- 3 Start executing your application to collect the profiling information.
- 4 When the execution stops, for instance because the program exit is reached or a breakpoint is triggered, you can view instruction level profiling information in the left-hand margin of the window.

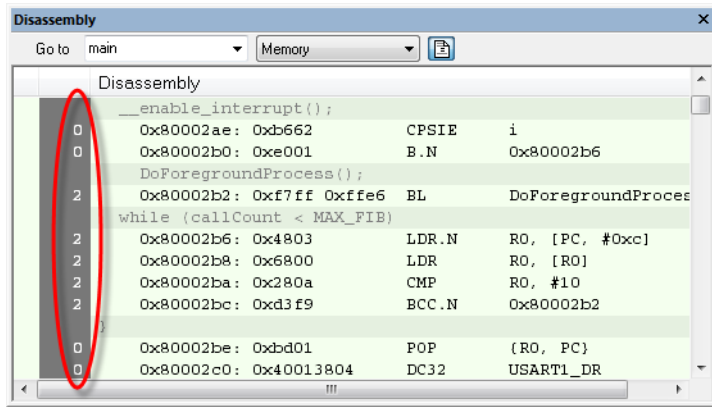

For each instruction, the number of times it has been executed is displayed.

Instruction profiling attempts to use the same source as the function profiler. If the function profiler is not on, the instruction profiler will try to use first trace and then PC sampling as source. You can change the source to be used from the context menu that is available in the **Function Profiler** window.

## SELECTING A TIME INTERVAL FOR PROFILING INFORMATION

Normally, the profiler computes its information from all PC samples it receives, accumulating more and more information until you explicitly clear the profiling information. However, you can choose a time interval for which the profiler computes the PC samples. This function is supported by the I-jet and I-jet Trace in-circuit debugging probes, the J-Link probe, the J-Trace probe, the ST-LINK probe, and the TI XDS probe.

### To select a time interval:

- 1 Choose **Function Profiler** from the C-SPY driver menu.
- 2 In the **Function Profiler** window, right-click and choose **Source: Sampling** from the context menu.
- 3 Execute your application to collect samples.
- 4 Choose **C-SPY driver>Timeline**.
- 5 In the **Timeline** window, click and drag to select a time interval.

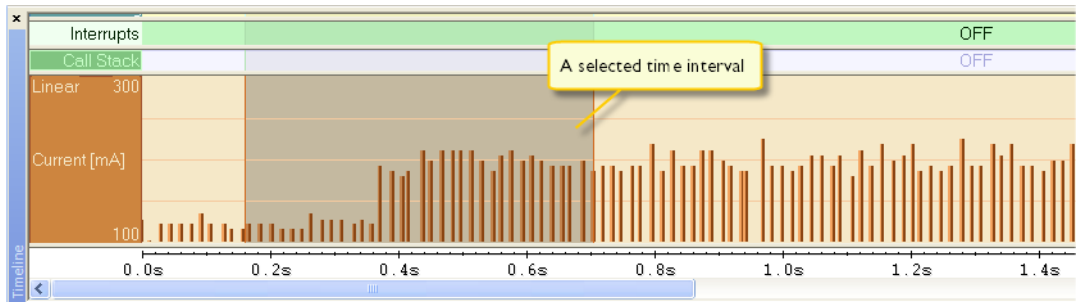

- 6 In the selected time interval, right-click and choose **Profile Selection** from the context menu.

The **Function Profiler** window now displays profiling information for the selected time interval.

Function	PC Count	PC Count (%)	Power Samples	Energy (%)	Average
GetButtons()	791	33.10	9	30.82	196
Dly100us(void *)	463	19.37	7	15.38	127
GLCD_SPI_TranserByte(Int3...	353	14.77	4	8.32	120
memcmp	325	13.60	4	14.64	212
main()	288	12.05	6	20.07	193
GLCD_Backlight(Int8U)	108	4.52	2	6.77	196
GLCD_SendCmd(GLCD_Cm...	43	1.80	0	0.00	-
GLCD_SPI_SendBlock(plnt8...	19	0.79	2	4.00	116
GLCD_SetWindow(Int32U, Int...	0	0.00	0	0.00	-
GLCD_SetReset(Boolean)	0	0.00	0	0.00	-

- 7 Click the **Full/Time-interval profiling** button to toggle the Full profiling view.

## Reference information on the profiler

Reference information about:

- *Function Profiler window*, page 301

See also:

- *Disassembly window*, page 83
- *ETM Trace Settings dialog box (J-Link/J-Trace)*, page 221
- *ETM Trace Settings dialog box (I-jet)*, page 219
- *SWO Trace Window Settings dialog box*, page 223



- *SWO Configuration dialog box*, page 225

## Function Profiler window

The **Function Profiler** window is available from the C-SPY driver menu.

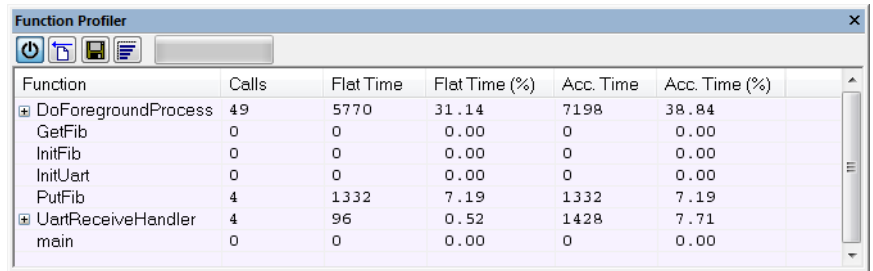

Function	Calls	Flat Time	Flat Time (%)	Acc. Time	Acc. Time (%)
<input checked="" type="checkbox"/> DoForegroundProcess	49	5770	31.14	7198	38.84
<input type="checkbox"/> GetFib	0	0	0.00	0	0.00
<input type="checkbox"/> InitFib	0	0	0.00	0	0.00
<input type="checkbox"/> InitUart	0	0	0.00	0	0.00
<input type="checkbox"/> PutFib	4	1332	7.19	1332	7.19
<input checked="" type="checkbox"/> UartReceiveHandler	4	96	0.52	1428	7.71
<input type="checkbox"/> main	0	0	0.00	0	0.00

This window displays function profiling information.

When Trace (flat) is selected, a checkbox appears on each line in the left-side margin of the window. Use these checkboxes to include or exclude lines from the profiling. Excluded lines are dimmed but not removed.

See also *Using the profiler*, page 295.

## Requirements

One of these alternatives:

- The C-SPY Simulator. Not available for all cores and devices.
- The C-SPY I-jet driver
- The C-SPY J-Link/J-Trace driver
- The C-SPY CMSIS-DAP driver
- The C-SPY ST-LINK driver
- The C-SPY TI XDS driver

## Toolbar

The toolbar contains:



### Enable/Disable

Enables or disables the profiler.



### Clear

Clears all profiling data.

**Save**

Opens a standard **Save As** dialog box where you can save the contents of the window to a file, with tab-separated columns. Only non-expanded rows are included in the list file.

**Graphical view**

Overlays the values in the percentage columns with a graphical bar.

***Progress bar***

Displays a backlog of profiling data that is still being processed. If the rate of incoming data is higher than the rate of the profiler processing the data, a backlog is accumulated. The progress bar indicates that the profiler is still processing data, but also approximately how far the profiler has come in the process.

Note that because the profiler consumes data at a certain rate and the target system supplies data at another rate, the amount of data remaining to be processed can both increase and decrease. The progress bar can grow and shrink accordingly.

**Time-interval mode**

Toggles between profiling a selected time interval or full profiling. This toolbar button is only available if PC Sampling is supported by the debug probe.

For information about which views that are supported in the C-SPY driver you are using, see *Requirements for using the profiler*, page 294.

***Status field***

Displays the range of the selected time interval, in other words, the profiled selection. This field is yellow when Time-interval profiling mode is enabled. This field is only available if PC Sampling is supported by the debug probe (SWO trace).

For information about which views that are supported in the C-SPY driver you are using, see *Requirements for using the profiler*, page 294.

**Display area**

The content in the display area depends on which source that is used for the profiling information:

- *For the Trace (calls) source*, the display area contains one line for each function compiled with debug information enabled. When some profiling information has been collected, it is possible to expand rows of functions that have called other functions. The child items for a given function list all the functions that have been called by the parent function and the corresponding statistics.

- *For the Trace (flat) source*, the display area contains one line for each C function of your application, but also lines for sections of code from the runtime library or from other code without debug information, denoted only by the corresponding assembler labels. Each executed PC address from trace data is treated as a separate sample and is associated with the corresponding line in the **Profiling** window. Each line contains a count of those samples.

For information about which views that are supported in the C-SPY driver you are using, see *Requirements for using the profiler*, page 294.

More specifically, the display area provides information in these columns:

**Function (All sources)**

The name of the profiled C function.

For Sampling source, sections of code from the runtime library or from other code without debug information, denoted only by the corresponding assembler labels, is displayed.

**Calls (Trace (calls))**

The number of times the function has been called.

**Flat time (Trace (calls))**

The time expressed in cycles spent inside the function.

**Flat time (%) (Trace (calls))**

Flat time expressed as a percentage of the total time.

**Acc. time (Trace (calls))**

The time expressed in cycles spent inside the function and everything called by the function.

**Acc. time (%) (Trace (calls))**

Accumulated time expressed as a percentage of the total time.

**PC Count (Trace (flat) and Sampling)**

The number of executed instructions (Trace) or PC samples (Sampling) associated with the function.

**PC Count (%) (Trace (flat) and Sampling)**

The number of executed instructions (Trace) or PC samples (Sampling) associated with the function as a percentage of the total number of executed instructions /PC samples.

**Power Samples (Power Sampling)**

The number of power samples associated with that function.

**Energy (%) (Power Sampling)**

The accumulated value of all measurements associated with that function, expressed as a percentage of all measurements.

**Avg Current [mA] (Power Sampling)**

The average measured value for all samples associated with that function.

**Min Current [mA] (Power Sampling)**

The minimum measured value for all samples associated with that function.

**Max Current [mA] (Power Sampling)**

The maximum measured value for all samples associated with that function.

**Context menu**

This context menu is available:

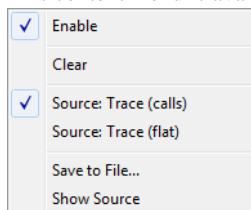

The contents of this menu depend on the C-SPY driver you are using.

These commands are available:

**Enable**

Enables the profiler. The system will also collect information when the window is closed.

**Clear**

Clears all profiling data.

**Filtering**

Selects which part of your code to profile. Choose between:

**Check All**—Excludes all lines from the profiling.

**Uncheck All**—Includes all lines in the profiling.

**Load**—Reads all excluded lines from a saved file.

**Save**—Saves all excluded lines to a file. Typically, this can be useful if you are a group of engineers and want to share sets of exclusions.

These commands are only available when using one of the modes Trace (flat) or Sampling.

**Source**

Selects which source to be used for the profiling information. See also *Profiling sources*, page 294.

Note that the available sources depend on the C-SPY driver you are using.

Choose between:

**Sampling**—the instruction count for instruction profiling represents the number of samples for each instruction.

**Trace (calls)**—the instruction count for instruction profiling is only as complete as the collected trace data.

**Trace (flat)**—the instruction count for instruction profiling is only as complete as the collected trace data.

**Power Sampling**

Toggles power sampling information on or off. This command is supported by the I-jet and I-jet Trace in-circuit debugging probes, the J-Link, and the J-Link Ultra debug probes.

**Save to File**

Saves all profiling data to a file.

**Show Source**

Opens the editor window (if not already opened) and highlights the selected source line.



# Code coverage

- Introduction to code coverage
- Reference information on code coverage

---

## Introduction to code coverage

These topics are covered:

- Reasons for using code coverage
- Briefly about code coverage
- Requirements and restrictions for using code coverage

### REASONS FOR USING CODE COVERAGE

The code coverage functionality is useful when you design your test procedure to verify whether all parts of the code have been executed. It also helps you identify parts of your code that are not reachable.

### BRIEFLY ABOUT CODE COVERAGE

The **Code Coverage** window reports the status of the current code coverage analysis for C or C++ code. For every program, module, and function, the analysis shows the percentage of code that has been executed since code coverage was turned on up to the point where the application has stopped. In addition, all statements that have not been executed are listed. The analysis will continue until turned off.

For debug probes that support it, C-SPY can capture full instruction trace in real time, and process the information for the **Code Coverage** window.

**Note:** Assembler code is not covered in the **Code Coverage** window. To view code coverage for assembler code, use the **Disassembly** window.

### REQUIREMENTS AND RESTRICTIONS FOR USING CODE COVERAGE

Code coverage is supported by the C-SPY simulator for most cores and devices and if supported there are no specific requirements or restrictions.

To use code coverage in your hardware debugger system, consider these requirements and restrictions:

- *When SWO trace is used*—code coverage information is based on trace samples only. This means that a function must be executed several times before 100% code coverage is reached. Also, no code coverage information is collected while single stepping.
- *When ETM trace is used*—for some devices, code coverage can be of infinite length. Without this enhanced trace capability, the coverage length is restricted by the size of the trace buffer. For efficient use of the trace buffer, you can limit the trace data collection using the trace start and trace stop breakpoints.
- Real-time code coverage requires that the debug probe supports this feature.
- Run code coverage on non-optimized code, as optimizations will negatively affect code coverage.

## Reference information on code coverage

Reference information about:

- *Code Coverage window*, page 308

See also *Single stepping*, page 76.

## Code Coverage window

The **Code Coverage** window is available from the **View** menu.

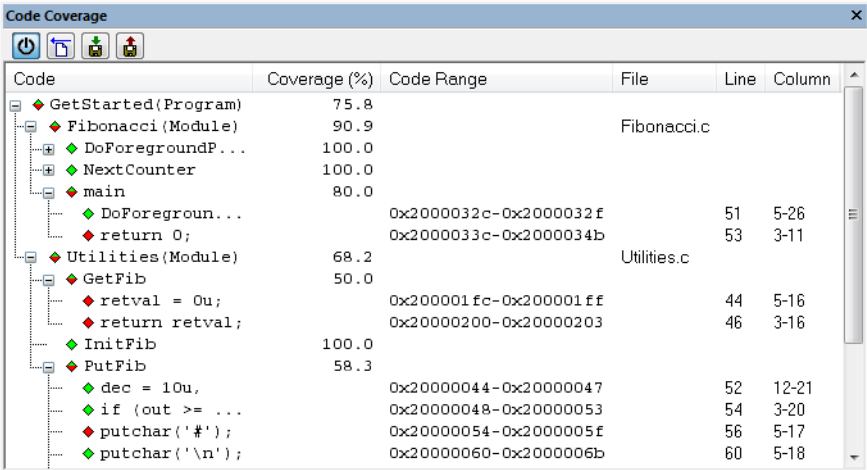

Code	Coverage (%)	Code Range	File	Line	Column
◆ GetStarted(Program)	75.8				
◆ Fibonacci (Module)	90.9		Fibonacci.c		
◆ DoForegroundP...	100.0				
◆ NextCounter	100.0				
◆ main	80.0				
◆ DoForegroun...		0x2000032c-0x2000032f		51	5-26
◆ return 0;		0x2000033c-0x2000034b		53	3-11
◆ Utilities (Module)	68.2		Utilities.c		
◆ GetFib	50.0				
◆ retval = 0u;		0x200001fc-0x200001ff		44	5-16
◆ return retval;		0x20000200-0x20000203		46	3-16
◆ InitFib	100.0				
◆ PutFib	58.3				
◆ dec = 10u;		0x20000044-0x20000047		52	12-21
◆ if (out >= ...		0x20000048-0x20000053		54	3-20
◆ putchar('#');		0x20000054-0x2000005f		56	5-17
◆ putchar('\n');		0x20000060-0x2000006b		60	5-18



This window reports the status of the current code coverage analysis. For every program, module, and function, the analysis shows the percentage of code that has been executed since code coverage was turned on up to the point where the application has stopped. In addition, all statements that have not been executed are listed. The analysis will continue until turned off.

Only source code that was compiled with debug information is displayed. Therefore, startup code, exit code, and library code are not displayed in the window. Furthermore, coverage information for statements in inlined functions is not displayed. Only the statement containing the inlined function call is marked as executed.

A statement is considered to be executed when all its instructions have been executed. By default, when a statement has been executed, it is removed from the window and the percentage is increased correspondingly.

## Requirements

One of these alternatives:

- The C-SPY Simulator. Not available for all cores and devices.
- The C-SPY I-jet driver
- The C-SPY J-Link/J-Trace driver
- The C-SPY CMSIS-DAP driver
- The C-SPY ST-LINK driver
- The C-SPY TI XDS driver

## Display area

Double-clicking a statement or a function in the **Code Coverage** window displays that statement or function as the current position in the editor window, which becomes the active window.

These columns are available:

### Code

The code coverage information is displayed as a tree structure, showing the program, module, function, and statement levels. You can use the plus (+) sign and minus (-) sign icons to expand and collapse the structure.

These icons give you an overview of the current status on all levels:

- Red diamond—0% of the modules or functions has been executed.
- Green diamond—100% of the modules or functions has been executed.
- Red and green diamond—Some of the modules or functions have been executed. This is most directly visible at the instruction level for a branch instruction or a conditionally executed instruction. For example, coverage

data can indicate that while a branch instruction has executed, control flow has not both branched and continued in straight execution. Or, in the case of a conditional instruction, it indicates if the instruction has executed both with the controlling flag set, and with the controlling flag not set.

Red, green, and yellow colors can be used as highlight colors in the source editor window. In the editor window, the yellow color signifies partially executed.

### Coverage (%)

The amount of statements that has been covered so far, that is, the number of executed statements divided with the total number of statements.

### Code Range

The address range in code memory where the statement is located.

### File

The source file where the step point is located.

### Line

The source file line where the step point is located.

### Column

The source file column where the step point is located.

## Context menu

This context menu is available:

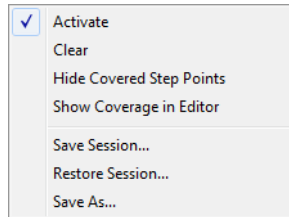

These commands are available:



### Activate

Switches code coverage on and off during execution.



### Clear

Clears the code coverage information. All step points are marked as not executed.

### Hide Covered Step Points

Toggles the display of covered step points on and off. When this option is selected, executed statements are removed from the window.

**Show Coverage in Editor**

Toggles the red, green, and yellow highlight colors that indicate code coverage in the source editor window on and off.

**Save session**

Saves your code coverage session data to a \*.dat file. This is useful if you for some reason must abort your debug session, but want to continue the session later on. This command is available on the toolbar. This command is only supported by the C-SPY simulator.

**Restore session**

Restores previously saved code coverage session data. This is useful if you for some reason must abort your debug session, but want to continue the session later on. This command is available on the toolbar. This command is only supported by the C-SPY simulator.

**Save As**

Saves the current code coverage result in a text file.



# Performance monitoring

- Introduction to performance monitoring
- Setting up performance monitoring
- Reference information on performance monitoring

---

## Introduction to performance monitoring

These topics are covered:

- Briefly about performance monitoring
- Requirements and restrictions for using performance monitoring
- Event types
- Detecting counter overflow

### BRIEFLY ABOUT PERFORMANCE MONITORING

The **Performance Monitoring** window is a viewer for counting events or CPU clock cycles through the Performance Monitoring Unit (PMU) available on Cortex-A, Cortex-R, and some Cortex-M devices. Cortex-M devices must be based on the Armv8.1M architecture.

To monitor event counters or CPU cycles through the PMU in the **Performance Monitoring** window, you must first make settings in the window and select the events that you want to monitor.

### REQUIREMENTS AND RESTRICTIONS FOR USING PERFORMANCE MONITORING

To use performance monitoring in your hardware debugger system, consider these requirements and restrictions:

- This feature requires an I-jet or J-Link probe.
- The target device must be equipped with a PMU. There are different PMU protocol versions available. C-SPY can handle all versions from PMUv1 and higher.

**Note:** The PMU on Arm v8-A (or higher) devices is not supported by the C-SPY **Performance Monitoring** window.

- To use **Auto-Update** on a Cortex-A or Cortex-R device, IAR Embedded Workbench also requires a probe with a driver that can connect to the PMU through

a debug access point (DAP)—currently only available with the I-jet family of probes—and the target must have memory-mapped registers. If these requirements are not met, the values of the event counters will only be updated when the application execution is stopped. For a Cortex-M device equipped with a PMU, DAP is not required for enabling Auto-Update, but currently only the I-jet family of probes are officially supported by C-SPY.



When the **Performance Monitoring** window is open, the PMU registers in the **Registers** window (if visible) cannot be modified and their values cannot be reliably synced with the values in the **Performance Monitoring** window.

**Note:** For Armv7 and Armv8 devices, the PMU counters use 32-bit registers (for Armv8.1M devices, the PMU counters only use 16-bit registers), but the values in the **Performance Monitoring** window will show 64-bit data, taking into account counter overflows.

## EVENT TYPES

The PMU is designed to count different types of events. There are two categories of events—*common events* and *implementation-defined* events.

### Common events

If implemented, a common event must comply with the definitions given by the Arm Architecture specification. The **Performance Monitoring** window provides a standard list of these events. If a common event is not implemented in the target device, the counter will not increment. Therefore, you are responsible for knowing whether or not an event has been implemented in the device you are using.

### Implementation-defined events

An implementation-defined event is more dependent on the target device, which gives the chip manufacturer more freedom in the design. However, Arm strongly recommends that the implementation conforms to the definitions in the Arm Architecture specification.

The implementation-defined event list in C-SPY can contain events specific to the current device. The **Performance Monitoring** window manages functions for loading and saving this list as a text file that you can create and modify. Examples of architecture specific implementation-defined event lists are provided in the directory `arm\src\PMU`. This list is also automatically saved in the project settings file in the current IAR Embedded Workbench project folder when C-SPY exits.

## DETECTING COUNTER OVERFLOW

Counter overflow occurs when the highest bit (bit 31 on 32-bit registers) in a PMU counter changes from 1 to 0. This change can be seen in the `PMOVSr` register in **32-bit mode**, and in the `PMOVSr_EL0` register in **64-bit mode** (which is only available for Armv8 devices). For Armv8.1M devices, the register is named `PMU_OVSr`.

If **Auto-Update** is enabled, the overflows will be incremented when detected, and shown in the **Overflow** column in the **Performance Monitoring** window.

If **Auto-Update** is disabled, C-SPY will not be able to keep track of the overflows, which makes the values of the counters in the **Value** column unreliable. Whenever the execution is paused and an overflow is detected in a counter, there is no way for C-SPY to know if there has been more than one overflow during execution. In general, the values in the **Value** column are unreliable whenever the corresponding counters show a value less than zero (0) in the **Overflow** column.

Occasionally, a value in the **Value** column might show an asterisk (\*) before the actual value and a tooltip with the word **Overflow** when the mouse pointer hovers over the affected counter value. This indicates that the overflow bit for that counter is set, but C-SPY has not yet updated the value and incremented the overflow count in the **Overflow** column.

---

## Setting up performance monitoring

To monitor event counters or CPU cycles through the PMU in the **Performance Monitoring** window, you must make settings in the window and select the events that you would like to monitor.

### To set up performance monitoring:

- 1 When the debug probe is connected, choose *C-SPY driver*>**Performance Monitoring**.
- 2 In the **Performance Monitoring** window, right-click and choose **Enable Performance Monitoring** from the context menu.
- 3 For each counter, use the context menu options to select a common or implementation-defined event that you want to monitor.

When you run the application, the event counters or CPU cycles through the PMU are displayed in the **Performance Monitoring** window.

## Reference information on performance monitoring

Reference information about:

- *Performance Monitoring window*, page 316

### Performance Monitoring window

The **Performance Monitoring** window is available from the **C-SPY driver** menu during a debug session.

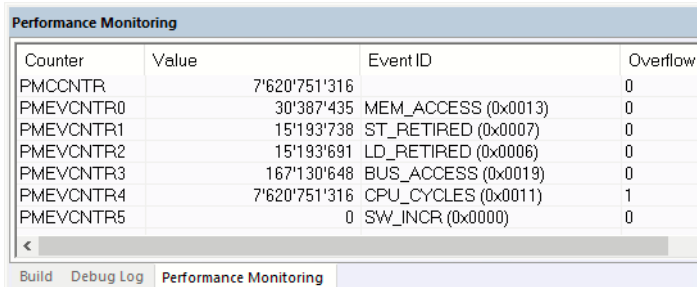

Counter	Value	Event ID	Overflow
PMCCNTR	7'620'751'316		0
PMEVCNTR0	30'387'435	MEM_ACCESS (0x0013)	0
PMEVCNTR1	15'193'738	ST_RETIRED (0x0007)	0
PMEVCNTR2	15'193'691	LD_RETIRED (0x0006)	0
PMEVCNTR3	167'130'648	BUS_ACCESS (0x0019)	0
PMEVCNTR4	7'620'751'316	CPU_CYCLES (0x0011)	1
PMEVCNTR5	0	SW_INCR (0x0000)	0

Build Debug Log Performance Monitoring

Use this window to monitor counting events or CPU clock cycles through the PMU.

**Note:** The names of the counters in this window can be used as pseudo-variables in other windows, such as a Watch-type window.

#### Requirements

A debug probe with support for performance monitoring and one of these alternatives:

- The C-SPY I-jet driver
- The C-SPY J-Link/J-Trace driver

#### Display area

This area contains a description of the most recent fault exception that was encountered during application execution.

This area contains these columns:

##### Counter

The names of the counters.

##### Value

The resulting counts.



**Event ID**

The assigned event IDs for the counter.

**Overflow**

The number of detected overflows.

**Context menu**

This context menu is available for setting up and managing events and counter results:

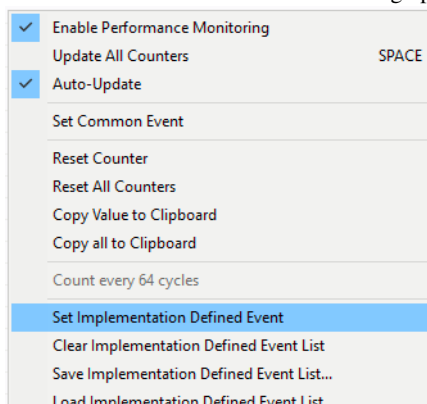
**Enable Performing Monitoring**

Enables performance monitoring.

**Update All Counters**

If the PMU can be accessed at runtime (that is, when the PMU registers are memory-mapped and are accessible at runtime), this menu command refreshes the values of all counters, including `PMCCNTR`, otherwise it will be unavailable.

**Auto-Update**

This option is only available when the PMU registers can be accessed at runtime. If enabled, the **Performance Monitoring** window automatically refreshes at regular intervals. The time between each refresh is controlled by the **LiveWatch** setting on the **Tools>Options>Debugger** page.

During execution, C-SPY also accumulates overflows and adds them to the total value of each respective counter.

Note that if the **Auto-Update** refresh rate is set too low, a PMU register might overflow more than once during execution, which will make the total counts unreliable. Make sure that the updates are made at least once for the smallest register, assuming that it increments with the same frequency as the cycle counter.

### **Set Common Event**

Opens the list of common events. The selected event will be assigned to the currently selected counter.

Note that this menu item does not work for `PMCCNTR`.

### **Reset Counter**

Resets the currently selected counter. This operation also resets the Overflow for that counter in the `PMOVSr` register.

### **Reset All Counters**

Resets all counters, including `PMCCNTR`. This operation also resets all Overflow bits in the `PMOVSr` register.

### **Copy Value to Clipboard**

Copies the value of the currently selected counter excluding the overflow asterisk (\*) marker.

### **Copy all to Clipboard**

Copies the entire contents of the window. The operation creates a table where each column is separated by a Tab character, and each line contains a counter.

### **Count every 64 cycles**

When selected, sets the `PMCR.D` bit, which makes the `PMCCNTR` only count every 64th clock cycle. This is useful to make the counting last longer before the overflow bit is set. `C-SPY` automatically multiplies the number of counts by 64. Note that this decreases the accuracy of the cycle counting.

### **Set Implementation Defined Event**

Opens a menu with implementation-defined events. The selected event will be assigned to the currently selected counter.

Note that this menu item does not work for `PMCCNTR`.

### **Clear Implementation Defined Event List**

Clears the list of implementation-defined events.

### **Save Implementation Defined Event List**

Opens a standard **File Save** dialog box from which you can choose a filename to save the current implementation-defined event list. The saved file is a text file where each line contains the ID, name, and description of an event, separated by spaces or tabs. The ID is stored as a hexadecimal number beginning with `0x`.

### Load Implementation Defined Event List

Opens a standard **File Open** dialog box from which you can load a list of implementation-defined events, where each line should contain the ID, name, and description of an event, separated by spaces or tabs.

The format is defined as this:

- The first element must be a decimal or hexadecimal number (where hexadecimal numbers must start with 0x)
- The second element must be a name containing letters, numbers, or underscores
- The last element can contain any text, but C-SPY will trim off the starting and ending spaces when the file is loaded
- If a line does not follow this syntax, it will be silently ignored.

For example, the first line in a file containing the Armv8 implementation-defined event list should look like this:

```
0x0040 L1D_CACHE_RD Attribute Level 1 data cache access, read
```

Note that there are no restrictions to the type of spacing used between the elements in a line. However, a Tab character is usually preferred for editing purposes.



# Power debugging

- Introduction to power debugging
- Optimizing your source code for power consumption
- Debugging in the power domain
- Reference information on power debugging

---

## Introduction to power debugging

These topics are covered:

- Reasons for using power debugging
- Briefly about power debugging
- Requirements and restrictions for power debugging

### REASONS FOR USING POWER DEBUGGING

Long battery lifetime is a very important factor for many embedded systems in almost any market segment—medical, consumer electronics, home automation, etc. The power consumption in these systems does not only depend on the hardware design, but also on how the hardware is used. The system software controls how it is used.

For examples of when power debugging can be useful, see *Optimizing your source code for power consumption*, page 323.

### BRIEFLY ABOUT POWER DEBUGGING

Power debugging is based on the ability to sample the power consumption—more precisely, the power being consumed by the CPU and the peripheral units—and correlate each sample with the application’s instruction sequence and hence with the source code and various events in the program execution.

Traditionally, the main software design goal has been to use as little memory as possible. However, by correlating your application’s power consumption with its source code you can gain insight into how the software affects the power consumption, and thus how it can be minimized.

## Measuring power consumption

The debug probe measures the voltage drop across a small resistor in series with the supply power to the device. The voltage drop is measured by a differential amplifier and then sampled by an AD converter.

The TI MSP-FET and TI XDS 110 debug probes use EnergyTrace™ Technology support to measure the power supplied to a target microcontroller. A software-controlled DC–DC converter generates the target power supply. The time density of the DC–DC converter charge pulses equals the power consumption of the target microcontroller. A built-in on-the-fly calibration circuit defines the energy equivalent of a single DC–DC charge pulse.

## Power debugging using C-SPY

C-SPY provides an interface for configuring your power debugging and a set of windows for viewing the power values:

- The **Power Log Setup** window is where you can specify a threshold and an action to be executed when the threshold is reached. This means that you can enable or disable the power measurement or you can stop the application's execution and determine the cause of unexpected power values.
- The **Power Log** window displays all logged power values. This window can be used for finding peaks in the power logging and because the values are correlated with the executed code, you can double-click on a value in the **Power Log** window to get the corresponding code. The precision depends on the frequency of the samples, but there is a good chance that you find the source code sequence that caused the peak.
- The Power graph in the **Timeline** window displays power values on a time scale. This provides a convenient way of viewing the power consumption in relation to the other information displayed in the window. The **Timeline** window is correlated to both the **Power Log** window, the source code window, and the **Disassembly** window, which means you are just a double-click away from the source code that corresponds to the values you see on the timeline.
- The **Function Profiler** window combines the function profiling with the power logging to display the power consumption per function—power profiling. You will get a list of values per function and also the average values together with max and min values. Thus, you will find the regions in the application that you should focus when optimizing for power consumption.

## REQUIREMENTS AND RESTRICTIONS FOR POWER DEBUGGING

To use the features in C-SPY for power debugging, you need one of these:

- An I-jet or I-jet Trace in-circuit debugging probe. Note that power debugging is not possible when using I-jet Trace with ETM.

For more accurate power debugging, you can connect the I-scope probe between the I-jet/I-jet Trace probe and the target board. I-scope adds detailed current and voltage measurement capability.

- A J-Link Ultra debug probe and a Cortex-M device with SWO.
- A TI MSP-FET debug probe, featuring the EnergyTrace™ technology provided by Texas Instruments, and a TI MSP-FET device. The probe outputs voltage, current, and energy information.
- An ST STLINK-V3PWR debug probe and a Cortex-M device with SWO. The target board should be powered via the probe.
- A TI XDS110 debug probe, featuring the EnergyTrace™ technology provided by Texas Instruments, and a Texas Instruments device. The probe outputs voltage, current, and energy information.

---

## Optimizing your source code for power consumption

This section gives some examples where power debugging can be useful and hopefully help you identify source code constructions that can be optimized for low power consumption.

These topics are covered:

- Waiting for device status
- Software delays
- DMA versus polled I/O
- Low-power mode diagnostics
- CPU frequency
- Detecting mistakenly unattended peripherals
- Peripheral units in an event-driven system
- Finding conflicting hardware setups
- Analog interference

## WAITING FOR DEVICE STATUS

One common construction that could cause unnecessary power consumption is to use a poll loop for waiting for a status change of, for example a peripheral device.

Constructions like this example execute without interruption until the status value changes into the expected state.

```
while (USBD_GetState() < USBD_STATE_CONFIGURED);
while ((BASE_PMC->PMC_SR & MC_MCKRDY) != PMC_MCKRDY);
```

To minimize power consumption, rewrite polling of a device status change to use interrupts if possible, or a timer interrupt so that the CPU can sleep between the polls.

## SOFTWARE DELAYS

A software delay might be implemented as a `for` or `while` loop like for example:

```
i = 10000; /* A software delay */
do i--;
while (i != 0);
```

Such software delays will keep the CPU busy with executing instructions performing nothing except to make the time go by. Time delays are much better implemented using a hardware timer. The timer interrupt is set up and after that, the CPU goes down into a low power mode until it is awakened by the interrupt.

## DMA VERSUS POLLED I/O

DMA has traditionally been used for increasing transfer speed. For MCUs there are plenty of DMA techniques to increase flexibility, speed, and to lower power consumption. Sometimes, CPUs can even be put into sleep mode during the DMA transfer. Power debugging lets you experiment and see directly in the debugger what effects these DMA techniques will have on power consumption compared to a traditional CPU-driven polled solution.

## LOW-POWER MODE DIAGNOSTICS

Many embedded applications spend most of their time waiting for something to happen—receiving data on a serial port, watching an I/O pin change state, or waiting for a time delay to expire. If the processor is still running at full speed when it is idle, battery life is consumed while very little is being accomplished. So in many applications, the core is only active during a very small amount of the total time, and by placing it in a low-power mode during the idle time, the battery life can be extended considerably.

A good approach is to have a task-oriented design and to use an RTOS. In a task-oriented design, a task can be defined with the lowest priority, and it will only execute when there is no other task that needs to be executed. This idle task is the perfect place to implement power management. In practice, every time the idle task is activated, it sets the core into



a low-power mode. Many microprocessors and other silicon devices have a number of different low-power modes, in which different parts of the core can be turned off when they are not needed. The oscillator can for example either be turned off or switched to a lower frequency. In addition, individual peripheral units, timers, and the CPU can be stopped. The different low-power modes have different power consumption based on which peripherals are left turned on. A power debugging tool can be very useful when experimenting with different low-level modes.

You can use the Function profiler in C-SPY to compare power measurements for the task or function that sets the system in a low-power mode when different low-power modes are used. Both the mean value and the percentage of the total power consumption can be useful in the comparison.

## CPU FREQUENCY

Power consumption in a CMOS MCU is theoretically given by the formula:

$$P = f * U^2 * k$$

where  $f$  is the clock frequency,  $U$  is the supply voltage, and  $k$  is a constant.

Power debugging lets you verify the power consumption as a factor of the clock frequency. A system that spends very little time in sleep mode at 50 MHz is expected to spend 50% of the time in sleep mode when running at 100 MHz. You can use the power data collected in C-SPY to verify the expected behavior, and if there is a non-linear dependency on the clock frequency, make sure to choose the operating frequency that gives the lowest power consumption.

## DETECTING MISTAKENLY UNATTENDED PERIPHERALS

Peripheral units can consume much power even when they are not actively in use. If you are designing for low power, it is important that you disable the peripheral units and not just leave them unattended when they are not in use. But for different reasons, a peripheral unit can be left with its power supply on—it can be a careful and correct design decision, or it can be an inadequate design or just a mistake. If not the first case, then more power than expected will be consumed by your application. This will be easily revealed by the Power graph in the **Timeline** window. Double-clicking in the **Timeline** window where the power consumption is unexpectedly high will take you to the corresponding source code and disassembly code. In many cases, it is enough to disable the peripheral unit when it is inactive, for example by turning off its clock which in most cases will shut down its power consumption completely.

However, there are some cases where clock gating will not be enough. Analog peripherals like converters or comparators can consume a substantial amount of power even when the clock is turned off. The **Timeline** window will reveal that turning off the clock was not enough and that you need to turn off the peripheral completely.

## PERIPHERAL UNITS IN AN EVENT-DRIVEN SYSTEM

Consider a system where one task uses an analog comparator while executing, but the task is suspended by a higher-priority task. Ideally, the comparator should be turned off when the task is suspended and then turned on again once the task is resumed. This would minimize the power being consumed during the execution of the high-priority task.

This is a schematic diagram of the power consumption of an assumed event-driven system where the system at the point of time  $t_0$  is in an inactive mode and the current is  $I_0$ :

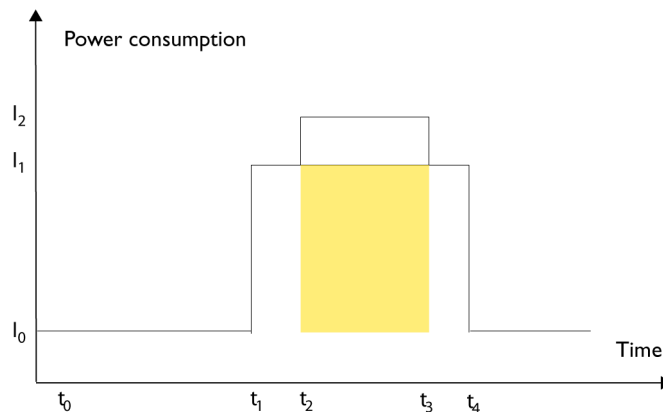

At  $t_1$ , the system is activated whereby the current rises to  $I_1$  which is the system's power consumption in active mode when at least one peripheral device turned on, causing the current to rise to  $I_1$ . At  $t_2$ , the execution becomes suspended by an interrupt which is handled with high priority. Peripheral devices that were already active are not turned off, although the task with higher priority is not using them. Instead, more peripheral devices are activated by the new task, resulting in an increased current  $I_2$  between  $t_2$  and  $t_3$  where control is handed back to the task with lower priority.

The functionality of the system could be excellent and it can be optimized in terms of speed and code size. But in the power domain, more optimizations can be made. The shadowed area represents the energy that could have been saved if the peripheral devices that are not used between  $t_2$  and  $t_3$  had been turned off, or if the priorities of the two tasks had been changed.

If you use the **Timeline** window, you can make a closer examination and identify that unused peripheral devices were activated and consumed power for a longer period than necessary. Naturally, you must consider whether it is worth it to spend extra clock cycles to turn peripheral devices on and off in a situation like in the example.

## FINDING CONFLICTING HARDWARE SETUPS

To avoid floating inputs, it is a common design practice to connect unused MCU I/O pins to ground. If your source code by mistake configures one of the grounded I/O pins as a logical 1 output, a high current might be drained on that pin. This high unexpected current is easily observed by reading the current value from the Power graph in the **Timeline** window. It is also possible to find the corresponding erratic initialization code by looking at the Power graph at application startup.

A similar situation arises if an I/O pin is designed to be an input and is driven by an external circuit, but your code incorrectly configures the input pin as output.

## ANALOG INTERFERENCE

When mixing analog and digital circuits on the same board, the board layout and routing can affect the analog noise levels. To ensure accurate sampling of low-level analog signals, it is important to keep noise levels low. Obtaining a well-mixed signal design requires careful hardware considerations. Your software design can also affect the quality of the analog measurements.

Performing a lot of I/O activity at the same time as sampling analog signals causes many digital lines to toggle state at the same time, which might introduce extra noise into the AD converter.

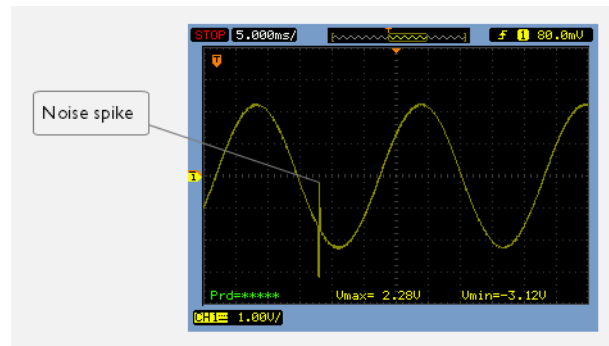

Power debugging will help you investigate interference from digital and power supply lines into the analog parts. Power spikes in the vicinity of AD conversions could be the source of noise and should be investigated. All data presented in the **Timeline** window is correlated to the executed code. Simply double-clicking on a suspicious power value will bring up the corresponding C source code.

---

## Debugging in the power domain

These tasks are covered:

- Displaying a power profile and analyzing the result
- Detecting unexpected power usage during application execution
- Changing the graph resolution

See also:

- *Timeline window—Power graph*, page 338
- *Selecting a time interval for profiling information*, page 299

### DISPLAYING A POWER PROFILE AND ANALYZING THE RESULT

#### To view the power profile:

- 1 Choose **C-SPY driver>SWO Configuration** to open the **SWO Configuration** dialog box. Make sure the CPU clock option is set to the same value as the CPU clock value set by your application. This is necessary to set the SWO clock and to obtain a correct data transfer to the debug probe.

This step requires a device with SWD SWO (Serial Wire Output) capability.

- 2 Start the debugger.
- 3 Choose **C-SPY driver>Power Log Setup**. In the **ID** column, make sure to select the alternatives for which you want to enable power logging.
- 4 Choose **C-SPY driver>Timeline** to open the **Timeline** window.
- 5 Right-click in the graph area and choose **Enable** from the context menu to enable the power graph you want to view.
- 6 Choose **C-SPY driver>Power Log** to open the **Power Log** window.
- 7 Optionally, if you want to correlate power values to specific interrupts or variables, right-click in the Interrupts or Data Logs graph area, respectively, and choose **Enable** from the context menu.

For variables, you also need to set a Data Log breakpoint for each variable you want a graphical representation of in the **Timeline** window. See *Data Log breakpoints dialog box (C-SPY hardware drivers)*, page 152.

This step requires a device with SWD SWO (Serial Wire Output) capability.

- 8 Optionally, before you start executing your application you can configure the viewing range of the Y-axis for the power graph. See *Viewing Range dialog box*, page 290.

- 9 Click **Go** on the toolbar to start executing your application. In the **Power Log** window, all power values are displayed. In the **Timeline** window, you will see a graphical representation of the power values, and, if you are using a device with SWD SWO (Serial Wire Output) capability, of the data and interrupt logs if you enabled these graphs. For information about how to navigate on the graph, see *Navigating in the graphs*, page 261.
- 10 To analyze power consumption (requires a device with SWD SWO capability):
  - Double-click on an interesting power value to highlight the corresponding source code in the editor window and in the **Disassembly** window. The corresponding log is highlighted in the **Power Log** window. For examples of when this can be useful, see *Optimizing your source code for power consumption*, page 323.
  - You can identify peripheral units to disable if they are not used. You can detect this by analyzing the power graph in combination with the other graphs in the **Timeline** window. See also *Detecting mistakenly unattended peripherals*, page 325.
  - For a specific interrupt, you can see whether the power consumption is changed in an unexpected way after the interrupt exits, for example, if the interrupt enables a power-intensive unit and does not turn it off before exit.
  - For function profiling, see *Selecting a time interval for profiling information*, page 299.

## DETECTING UNEXPECTED POWER USAGE DURING APPLICATION EXECUTION

### To detect unexpected power consumption:

- 1 Choose **C-SPY driver>SWO Configuration** to open the **SWO Configuration** dialog box. Make sure these settings are used:
  - **CPU clock** must be set to the same value as the CPU clock value set by your application. This is necessary to set the SWO clock and to obtain the correct data transfer rate to the debug probe.

This step requires a Cortex-M device with SWO.
- 2 Choose **C-SPY driver>Power Log Setup** to open the **Power Log Setup** window.
- 3 In the **Power Log Setup** window, specify a threshold value and the appropriate action, for example **Log All and Halt CPU Above Threshold**.
- 4 Choose **C-SPY driver>Power Log** to open the **Power Log** window. If you continuously want to save the power values to a file, choose **Choose Live Log File** from the context menu. In this case you also need to choose **Enable Live Logging to**.
- 5 Start the execution.

When the power consumption passes the threshold value, the execution will stop and perform the action you specified.

If you saved your logged power values to a file, you can open that file in an external tool for further analysis.

## CHANGING THE GRAPH RESOLUTION

### To change the resolution of a Power graph in the Timeline window:

- 1 In the **Timeline** window, select the Power graph, right-click and choose **Open Setup Window** to open the **Power Log Setup** window.
- 2 From the context menu in the **Power Log Setup** window, choose a suitable unit of measurement.
- 3 In the **Timeline** window, select the Power graph, right-click and choose **Viewing Range** from the context menu.
- 4 In the **Viewing Range** dialog box, select **Custom** and specify range values in the **Lowest value** and the **Highest value** text boxes. Click **OK**.
- 5 The graph is automatically updated accordingly.

---

## Reference information on power debugging

Reference information about:

- *Power Log Setup window*, page 331
- *Power Log window*, page 334
- *Timeline window—Power graph*, page 338
- *State Log window*, page 339
- *State Log Summary window*, page 341
- *Timeline window—State Log graph*, page 344

See also:

- *Trace window*, page 229
- *The application timeline*, page 257
- *Viewing Range dialog box*, page 290
- *Function Profiler window*, page 301

## Power Log Setup window

The **Power Log Setup** window is available from the C-SPY driver menu during a debug session.

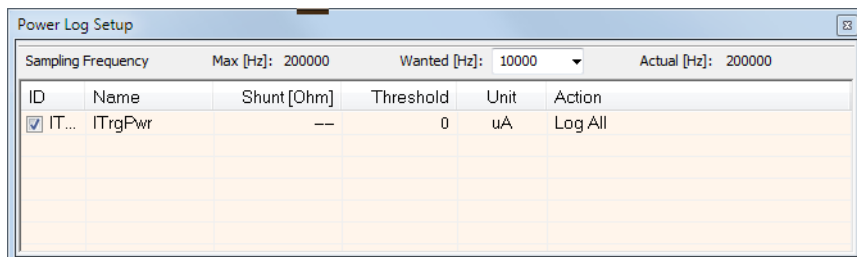

Use this window to configure the power measurement.

**Note:** To enable power logging, choose **Enable** from the context menu in the **Power Log** window or from the context menu in the power graph in the **Timeline** window.

See also *Debugging in the power domain*, page 328.

### Requirements

A debug probe with support for power debugging and one of these alternatives:

- The C-SPY I-jet driver
- The C-SPY J-Link/J-Trace driver
- The C-SPY ST-LINK driver
- The C-SPY TI MSP-FET driver
- The C-SPY TI XDS driver

### Sampling Frequency toolbar

Use this toolbar to override the default sampling frequency, and to inspect the maximum and the actual sampling frequency.

#### Max [Hz]

This is the maximum supported sampling frequency in Hertz.

#### Wanted [Hz]

Use this option to override the default sampling frequency. The frequency you enter will be rounded to the nearest possible value, and the **Actual [Hz]** value will be updated accordingly.

#### Actual [Hz]

This is the actual sampling frequency being used.

## Display area

This area contains these columns:

### ID

A unique string that identifies the measurement channel in the probe. Select the check box to activate the channel. If the check box is deselected, logs will not be generated for that channel.

### Name

Specify a user-defined name.

### Shunt [Ohm]

This column always contains -- (two dashes) for all debug probes except I-scope. For I-scope, specify the resistance of the shunt.

### Threshold

Specify a threshold value in the selected unit. The action you specify will be executed when the threshold value is reached.

### Unit

Displays the selected unit for power. You can choose a unit from the context menu.

### Action

Displays the selected action for the measurement channel. Choose between:

- **Log All**
- **Log Above Threshold**
- **Log Below Threshold**
- **Log All and Halt CPU Above Threshold**
- **Log All and Halt CPU Below Threshold**



## Context menu

This context menu is available:

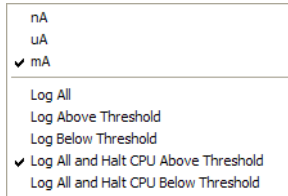

These commands are available:

### **nA, uA, mA**

Selects the unit for the power display. These alternatives are available for channels that measure current.

### **uV, mV, V**

Selects the unit for power display. These alternatives are available for channels that measure voltage.

### **uWs, mWs, Ws**

Selects the unit for power display. These alternatives are available for channels that measure energy.

### **Log All**

Logs all values.

### **Log Above Threshold**

Logs all values above the threshold.

### **Log Below Threshold**

Logs all values below the threshold.

### **Log All and Halt CPU Above Threshold**

Logs all values. If a logged value exceeds the threshold, execution is stopped. This might take a few execution cycles.

### **Log All and Halt CPU Below Threshold**

Logs all values. If a logged value goes below the threshold, execution is stopped. This might take a few execution cycles.

## Power Log window

The **Power Log** window is available from the C-SPY driver menu during a debug session.

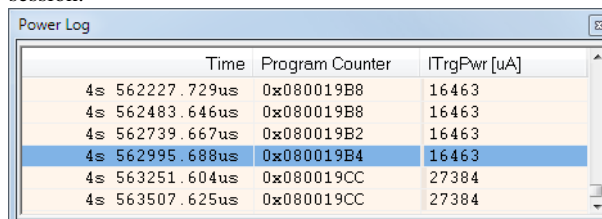

	Time	Program Counter	ITrgPwr [uA]
4s	562227.729us	0x080019B8	16463
4s	562483.646us	0x080019B8	16463
4s	562739.667us	0x080019B2	16463
4s	562995.688us	0x080019B4	16463
4s	563251.604us	0x080019CC	27384
4s	563507.625us	0x080019CC	27384

This window displays collected power values.

A row with only Time/Cycles displayed in pink denotes a logged power value for a channel that was active during the actual collection of data but currently is disabled in the **Power Log Setup** window.

**Note:** There is a limit on the number of saved logs. When this limit is exceeded, the oldest entries in the buffer are erased.

See also *Debugging in the power domain*, page 328.

### Requirements

A debug probe with support for power debugging and one of these alternatives:

- The C-SPY I-jet driver
- The C-SPY J-Link/J-Trace driver
- The C-SPY ST-LINK driver
- The C-SPY TI MSP-FET driver
- The C-SPY TI XDS driver

### Display area

This area contains these columns:

#### Time

The time from the application reset until the event, based on the clock frequency specified in the **SWO Configuration** dialog box.

If the time is displayed in italics, the target system could not collect a correct time, but instead had to approximate it.

This column is available when you have selected **Show Time** from the context menu.

**Cycles**

The number of cycles from the application reset until the event. This information is cleared at reset.

If a cycle is displayed in italics, the target system could not collect a correct time, but instead had to approximate it.

This column is available when you have selected **Show Cycles** from the context menu.

**Program Counter**

Displays one of these:

An address, which is the content of the PC, that is, the address of an instruction close to where the power value was collected.

---, the target system failed to provide the debugger with any information.

**Overflow** in red, the communication channel failed to transmit all data from the target system.

**Idle**, the power value is logged during idle mode.

Note that the **Program Counter** column is only available if your C-SPY debugger driver and device support it.

**Name [unit]**

The power measurement value expressed in the unit you specified in the **Power Log Setup** window.

## Context menu

This context menu is available:

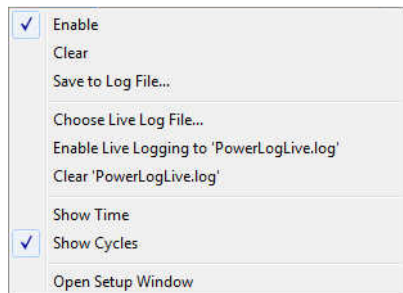

These commands are available:

### Enable

Enables the logging system, which means that power values are saved internally within the IDE. The values are displayed in the **Power Log** window and in the Power graph in the **Timeline** window (if enabled). The system will log information also when the window is closed.

### Clear

Deletes the log information. Note that this will also happen when you reset the debugger, or if you change the execution frequency in the **SWO Configuration** dialog box.

### Save to File

Displays a standard file selection dialog box where you can select the destination file for the log information. The entries in the log file are separated by `TAB` and `LF` characters. An **X** in the **Approx** column indicates that the timestamp is an approximation.

### Choose Live Log File

Displays a standard file selection dialog box where you can choose a destination file for the logged power values. The power values are continuously saved to that file during execution. The content of the live log file is never automatically cleared, the logged values are simply added at the end of the file.

### Enable Live Logging to

Toggles live logging on or off. The logs are saved in the specified file.

### Clear *log file*

Clears the content of the live log file.

**Show Time**

Displays the **Time** column. If the **Time** column is displayed by default in the C-SPY driver you are using, this menu command is not available.

**Show Cycles**

Displays the **Cycles** column. If the **Cycles** column is not supported in the C-SPY driver you are using, this menu command is not available.

**Open Setup Window**

Opens the **Power Log Setup** window.

**The format of the log file**

The log file has a tab-separated format. The entries in the log file are separated by TAB and line feed. The logged power values are displayed in these columns:

**Time/Cycles**

The time from the application reset until the power value was logged.

**Approx**

An **x** in the column indicates that the power value has an approximative value for time/cycle.

**PC**

The value of the program counter close to the point where the power value was logged.

**Name [unit]**

The corresponding value from the **Power Log** window, where *Name* and *unit* are according to your settings in the **Power Log Setup** window.

## Timeline window—Power graph

The power graph in the **Timeline** window is available from the C-SPY driver menu during a debug session.

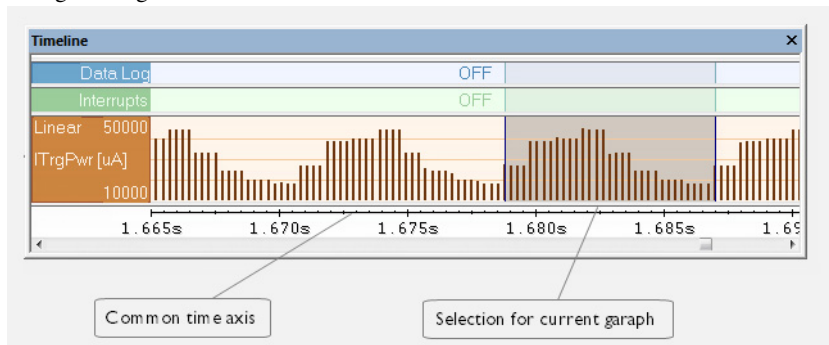

The power graph displays a graphical view of power measurement samples generated by the debug probe or associated hardware in relation to a common time axis.

**Note:** There is a limit on the number of saved logs. When this limit is exceeded, the oldest entries in the buffer are erased.

For more information about the **Timeline** window, how to display a graph, and the other supported graphs, see *The application timeline*, page 257.

See also *Requirements and restrictions for power debugging*, page 323.

### Requirements

A debug probe with support for power debugging and one of these alternatives:

- The C-SPY I-jet driver
- The C-SPY J-Link/J-Trace driver
- The C-SPY ST-LINK driver
- The C-SPY TI MSP-FET driver
- The C-SPY TI XDS driver

### Display area

Where:

- The label area at the left end of the graph displays the name of the measurement channel.

- The Voltage and the Current graphs show power measurement samples generated by the debug probe or associated hardware. The Energy graph shows accumulated energy since the last time the CPU was stopped.
- The graph can be displayed as a thin line between consecutive logs, as a rectangle for every log (optionally color-filled), or as columns.
- The resolution of the graph can be changed.
- A red vertical line indicates overflow, which means that the communication channel failed to transmit all interrupt logs from the target system.

At the bottom of the window, there is a common time axis that uses seconds as the time unit.

## State Log window

The **State Log** window is available from the C-SPY driver menu.

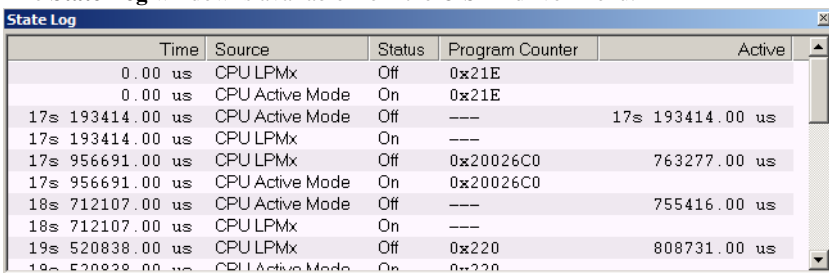

	Time	Source	Status	Program Counter	Active
	0.00 us	CPU LPMx	Off	0x21E	
	0.00 us	CPU Active Mode	On	0x21E	
17s	193414.00 us	CPU LPMx	Off	---	17s 193414.00 us
17s	193414.00 us	CPU Active Mode	On	---	
17s	956691.00 us	CPU LPMx	Off	0x20026C0	763277.00 us
17s	956691.00 us	CPU Active Mode	On	0x20026C0	
18s	712107.00 us	CPU LPMx	Off	---	755416.00 us
18s	712107.00 us	CPU Active Mode	On	---	
19s	520838.00 us	CPU LPMx	Off	0x220	808731.00 us
19s	520838.00 us	CPU Active Mode	On	0x220	

This window logs activity—state changes—for peripheral units and clocks, as well as for CPU modes.

The information is useful for tracing the activity on the target system. When the **State Log** window is open, it is updated continuously at runtime.

**Note:** The number of saved logs is limited. When this limit is exceeded, the entries at the beginning of the buffer are erased.

See also *Displaying a power profile and analyzing the result*, page 328 and *Timeline window—State Log graph*, page 344.

## Requirements

One of these alternatives:

- The C-SPY MSP-FET driver and a TI MSP-FET debug probe with EnergyTrace+™ Technology provided by Texas Instruments.

- The C-SPY TI XDS driver and a TI XDS110 debug probe with EnergyTrace+™ Technology provided by Texas Instruments, and one of the MSP432, CC13xx, or CC26xx devices.

## Display area

This area contains these columns:

### Time

The time for the state change, based on the sampling frequency.

If a time is displayed in italics, the target system has not been able to collect a correct time, but instead had to approximate it.

### Source

The name of the peripheral unit, clock, or CPU mode.

### Status

The status at the given time.

### Program Counter\*

The address of the program counter when the status changed, or shows **idle** if the log was taken during CPU idle mode, or shows --- for an unknown PC value.

### Active

The active time calculated using the on and off time for the source. If it is written in italics, it is based on at least one approximative time.

\* You can double-click an address. If it is available in the source code, the editor window displays the corresponding source code, for example for the interrupt handler (this does not include library source code).

## Context menu

This context menu is available:

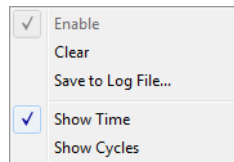

These commands are available:

### Enable

Enables the logging system. The system will log information also when the window is closed.



**Clear**

Deletes the log information. Note that this will also happen when you reset the debugger.

**Save to File**

Displays a standard file selection dialog box where you can select the destination file for the log information. The entries in the log file are separated by TAB and LF characters. An X in the **Approx** column indicates that the timestamp is an approximation.

**Show Time**

Displays the **Time** column.

If the **Time** column is always displayed by default in the C-SPY driver you are using, this menu command is not available.

**Show Cycles**

Displays the **Cycles** column.

If the C-SPY driver you are using does not support the **Cycles** column, this menu command is not available.

**State Log Summary window**

The **State Log Summary** window is available from the C-SPY driver menu.

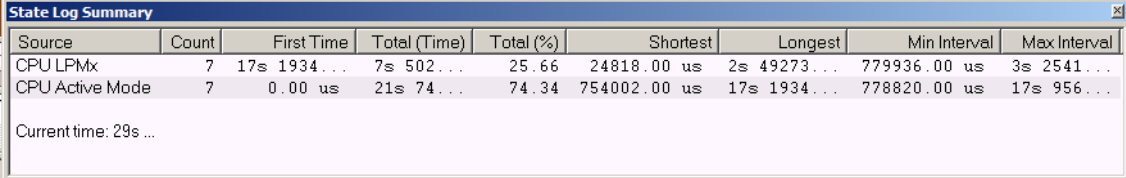

Source	Count	First Time	Total (Time)	Total (%)	Shortest	Longest	Min Interval	Max Interval
CPU LPMx	7	17s 1934...	7s 502...	25.66	24818.00 us	2s 49273...	779936.00 us	3s 2541...
CPU Active Mode	7	0.00 us	21s 74...	74.34	754002.00 us	17s 1934...	778820.00 us	17s 956...

Current time: 29s ...

This window displays a summary of logged activity—state changes—for peripheral units and clocks, as well as for CPU modes.

Click a column to sort it according to the values. Click again to reverse the sort order.

At the bottom of the display area, the current time or cycles is displayed—the number of cycles or the execution time since the start of execution.

See also *Displaying a power profile and analyzing the result*, page 328 and *Timeline window—State Log graph*, page 344.

**Requirements**

One of these alternatives:

- The C-SPY MSP-FET driver and a TI MSP-FET debug probe with EnergyTrace+™ Technology provided by Texas Instruments.
- The C-SPY TI XDS driver and a TI XDS110 debug probe with EnergyTrace+™ Technology provided by Texas Instruments, and one of the MSP432, CC13xx, or CC26xx devices.

## Display area

Each row in this area displays statistics about the specific measurement source based on the log information in these columns; and summary information is listed at the bottom of the display area:

### Source

The name of the peripheral unit, clock, or CPU mode.

### Count

The number of times the source was activated.

### First time

The first time the source was activated.

### Total (Time)\*\*

The accumulated time the source has been active.

### Total (%)

The accumulated time in percent that the source has been active.

### Shortest

The shortest time spent with this source active.

### Longest

The longest time spent with this source active.

### Min interval

The shortest time between two activations of this source.

### Max interval

The longest time between two activations of this source.

### Approximative time count

The information displayed depends on the C-SPY driver you are using.

For some C-SPY drivers, this information is not displayed or the value is always zero. In this case, all logs have an exact time stamp.

For other C-SPY drivers, a non-zero value is displayed. The value represents the amount of logs with an approximative time stamp. This might happen if the bandwidth in the communication channel is too low compared to the amount of data packets generated by the CPU or if the CPU generated packets with an approximative time stamp.

### Overflow count

The information displayed depends on the C-SPY driver you are using.

For some C-SPY drivers, this information is not displayed or the value is always zero.

For other C-SPY drivers, the number represents the amount of overflows in the communication channel which can cause logs to be lost. If this happens, it indicates that logs might be incomplete. To solve this, make sure not to use all C-SPY log features simultaneously or check used bandwidth for the communication channel.

### Current time/Current cycles

The information displayed depends on the C-SPY driver you are using.

For some C-SPY drivers, the value is always zero or not visible at all.

For other C-SPY drivers, the number represents the current time or cycles—the number of cycles or the execution time since the start of execution.

\*\* Calculated in the same way as for the Execution time/cycles in the **State Log** window.

## Context menu

This context menu is available:

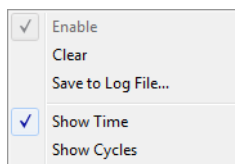

These commands are available:

### Enable

Enables the logging system. The system will log information also when the window is closed.

### Clear

Deletes the log information. Note that this will also happen when you reset the debugger.

**Save to File**

Displays a standard file selection dialog box where you can select the destination file for the log information. The entries in the log file are separated by `TAB` and `LF` characters. An **X** in the **Approx** column indicates that the timestamp is an approximation.

**Show Time**

Displays the **Time** column.

If the **Time** column is always displayed by default in the C-SPY driver you are using, this menu command is not available.

**Show Cycles**

Displays the **Cycles** column.

If the C-SPY driver you are using does not support the **Cycles** column, this menu command is not available.

**Timeline window—State Log graph**

The State Log graph in the **Timeline** window is available from the C-SPY driver menu during a debug session.

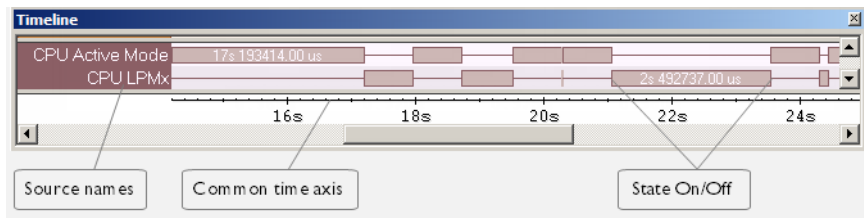

The **State Log** graph displays a graphical view of logged activity—state changes—for peripheral units and clocks, as well as CPU modes in relation to a common time axis.

For more information about the **Timeline** window, how to display a graph, and the other supported graphs, see *The application timeline*, page 257.

See also *Requirements and restrictions for power debugging*, page 323.

**Requirements**

One of the following combinations:

- The C-SPY MSP-FET driver and a TI MSP-FET debug probe with EnergyTrace+™ Technology provided by Texas Instruments.

- The C-SPY TI XDS driver and a TI XDS110 debug probe with EnergyTrace+™ Technology provided by Texas Instruments, and one of the MSP432, CC13xx, or CC26xx devices.

## Display area

Where:

- The label area at the left end of the graph displays the name of the sources of the status information.
- The graph itself shows the state of the peripheral units, clocks, and CPU modes generated by the debug probe or associated hardware. The white figure indicates the time spent in the state. This graph is a graphical representation of the information in the **State Log** window, see *State Log window*, page 339.

At the bottom of the window, there is a shared time axis that uses seconds as the time unit.

## Context menu

This context menu is available:

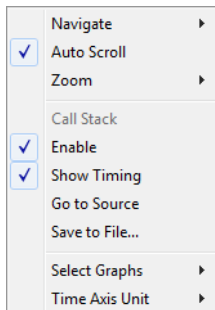

**Note:** The context menu contains some commands that are common to all graphs in the **Timeline** window and some commands that are specific to each graph.

These commands are available:

### Navigate

Commands for navigating the graph(s). Choose between:

**Next** moves the selection to the next relevant point in the graph. Shortcut key: right arrow.

**Previous** moves the selection backward to the previous relevant point in the graph. Shortcut key: left arrow.

**First** moves the selection to the first data entry in the graph. Shortcut key: Home.

**Last** moves the selection to the last data entry in the graph. Shortcut key: End.

**End** moves the selection to the last data in any displayed graph, in other words the end of the time axis. Shortcut key: Ctrl+End.

### Auto Scroll

Toggles automatic scrolling on or off. When on, the most recently collected data is automatically displayed when you choose **Navigate>End**.

### Zoom

Commands for zooming the window, in other words, changing the time scale. Choose between:

**Zoom to Selection** makes the current selection fit the window. Shortcut key: Return.

**Zoom In** zooms in on the time scale. Shortcut key: +

**Zoom Out** zooms out on the time scale. Shortcut key: –

**10ns, 100ns, 1us**, etc makes an interval of 10 nanoseconds, 100 nanoseconds, 1 microsecond, respectively, fit the window.

**1ms, 10ms**, etc makes an interval of 1 millisecond or 10 milliseconds, respectively, fit the window.

**10m, 1h**, etc makes an interval of 10 minutes or 1 hour, respectively, fit the window.

### Power Log

A heading that shows that the Power Log-specific commands below are available.

### Enable

Toggles the display of the graph on or off. If you disable a graph, that graph will be indicated as **OFF** in the window. If no data has been collected for a graph, **no data** will appear instead of the graph.

### Viewing Range

Displays a dialog box, see *Viewing Range dialog box*, page 290.

### Size

Determines the vertical size of the graph—choose between **Small, Medium,** and **Large**.

**Style**

Selects the style of the graph. Choose between:

**Bars**, displays a vertical bar for each log.

**Columns**, displays a column for each log.

**Levels**, displays the graph with a rectangle for each log, optionally color-filled.

**Linear**, displays the graph as a thin line between consecutive logs.

Note that all styles are not available for all graphs.

**Show Numerical Value**

Shows the numerical value of the variable, in addition to the graph.

**Go To Source**

Displays the corresponding source code in an editor window, if applicable.

**Open Setup Window**

Opens the **Power Log Setup** window.

**Select Graphs**

Selects which graphs to be displayed in the **Timeline** window.

**Time Axis Unit**

Selects the unit used in the time axis—choose between **Seconds** and **Cycles**.

If **Cycles** is not available, the graphs are based on different clock sources. In that case you can view cycle values as tooltip information by pointing at the graph with your mouse pointer.

**Profile Selection**

Enables profiling time intervals in the **Function Profiler** window. Note that this command is only available if the C-SPY driver supports PC Sampling. See *Selecting a time interval for profiling information*, page 299.





# C-RUN runtime error checking

- Introduction to runtime error checking
- Using C-RUN
- Detecting various runtime errors
- Reference information on runtime error checking
- Compiler and linker reference for C-RUN
- cspybat options for C-RUN

Note that the functionality described in this chapter requires C-RUN, which is an add-on product to IAR Embedded Workbench.

---

## Introduction to runtime error checking

These topics are covered:

- Runtime error checking
- Runtime error checking using C-RUN
- The checked heap provided by the library
- Using C-RUN in the IAR Embedded Workbench IDE
- Using C-RUN in non-interactive mode
- Requirements for runtime error checking

### **RUNTIME ERROR CHECKING**

Runtime error checking is a way of detecting erroneous code constructions when your application is running. This is done by instrumenting parts of the code in the application, or by replacing C/C++ library functionality with a dedicated library that contains support for runtime error checking.

Runtime error checking uses different methods for implementing the checks, depending on the type of your application and in what environment it should run.

Instrumenting the code to perform checks makes the code larger and slower. Variants of library functions with checks will also, in general, be larger and slower than the corresponding functions without checks.

## RUNTIME ERROR CHECKING USING C-RUN

C-RUN supports three types of runtime error checking:

- *Arithmetic checking*, which includes checking for integer overflow and underflow, erroneous shifts, division by zero, value-changing conversions, and unhandled cases in switch statements. Normally, the overhead of arithmetic checking is not particularly high, and arithmetic checking can be enabled or disabled on a module by module basis with no complications.
- *Bounds checking*, which checks whether accesses via pointers are within the bounds of the object pointed to. Bounds checking involves instrumenting the code to track pointer bounds, with relatively high costs in both code size and speed. A global table of bounds for indirectly accessed pointers is also needed. You can disable tracking, or just checking, per module or function, but any configuration where pointer bounds are not tracked by all code will usually require some source code adaption.
- *Heap checking using a checked heap*, which checks for errors in the use of heap memory. Heap checking can find incorrect write accesses to heap memory, double free, non-matching allocation and deallocation, and, with explicit calls, leaked heap blocks. Using the checked heap increases the memory size for each heap block, which might mean that you must increase your heap size, and heap operations can take significantly longer than with the normal heap. It also checks only when heap functions are called, which means that it will not catch all heap write errors.

All checks that C-RUN can perform can be used for both C and C++ source code.

You can enable several types of C-RUN checks at the same time. Each type of check that you enable will increase, sometimes very slightly, execution time and code size.

Sometimes, the compiler might merge several checks into one, or move a check out of a loop, in which case the problem may be detected well in advance of the actual access. In these cases, the C-RUN message will display the problem source location (or locations) as separate from the current location.

Before you perform any C-RUN runtime checks, make sure to use all the compiler's facilities for finding problems:

- Do not use Kernighan & Ritchie function declarations—use the prototyped style instead. Read about `--require_prototypes` in the *IAR C/C++ Development Guide for Arm*.

- Make sure to pay attention to any compiler warnings before you perform any runtime checking. The compiler will not, in most cases, emit code to check for a problem it has already warned about. For example:

```
unsigned char ch = 1000; /* Warning: integer truncation */
```

Even when integer conversion checking is enabled, the emitted code will not contain any check for this case, and the code will simply assign the value 232 (1000 & 255) to `ch`.

**Note:** C-RUN depends on the Arm semi-hosting interface (the library function `__iar_ReportCheckFailed` will communicate with C-SPY via the semihosting interface). It is only in non-interactive mode that you can use another low-level I/O interface. See *Using C-RUN in non-interactive mode*, page 352.

For information about how to detect the errors, see *Detecting various runtime errors*, page 355.

## THE CHECKED HEAP PROVIDED BY THE LIBRARY

The library provides a replacement *checked heap* that you can use for checking heap usage. The checked heap will insert guard bytes before and after the user part of a heap block, and will also store some extra information (including a sequential allocation number) in each block to help with reporting.

Each heap operation will normally check each involved heap block for changes to the guard bytes, or to the contents of newly allocated heap memory. At certain times (either triggered by a specific call, or after a configurable number of heap operations) a heap integrity check will be performed which checks the entire heap for problems.

It is important to know that the checked heap cannot find erroneous read accesses, like reading from a freed heap block, or reading outside the bounds of an allocated heap block. Bounds checking can find these, as well as many erroneous write accesses that might be missed by the checked heap because they do not write to a guard byte or an otherwise checked byte. The checked heap also checks only when a heap operation is used, and not at the actual point of access.

## USING C-RUN IN THE IAR EMBEDDED WORKBENCH IDE

C-RUN is fully integrated in the IAR Embedded Workbench IDE and it offers:

- Detailed error information with call stack information provided for each found error and code correlation and graphical feedback in editor windows on errors
- Error rule management to stop the execution, log, or ignore individual runtime errors, either on project level, file level, or at specific code locations. It is possible to load and save filter setups.

- A bookmark in the editor window for each message which makes it easy to navigate between the messages (using F4).

In the IDE, C-RUN provides these windows:

- The **C-RUN Messages** window, which lists all messages that C-RUN generates. Each message contains a message type (reflecting the check performed), a text that describes the problem, and a call stack. The corresponding source code statements will be highlighted in the editor window. See *C-RUN Messages window*, page 376.
- The **C-RUN Message Rules** window, which lists all rules. See *C-RUN Messages Rules window*, page 378. The rules determine which messages that are displayed in the **C-RUN Messages** window.

## USING C-RUN IN NON-INTERACTIVE MODE

You can run C-RUN checked programs using `cspybat`—C-SPY in batch mode. `cspybat` can use rules and other setup configured in the Workbench IDE. C-RUN messages in `cspybat` are by default reported to the host `stdout`, but you can redirect them to a file.

If you instead want to use your own communication channel between your application and the host for C-RUN messages, replace the function `__iar_ReportCheckFailed` (uses the semihosting interface for the communication) with your own version and you can use any communication interface you like. In the source file `ReportCheckFailedStdout.c` (`arm\src\lib\crun`) you can find a variant that reports to the application's `stdout`. To use your own report function instead of the semihosting one, use the linker option `--redirect`  
`__iar_ReportCheckFailed=__iar_ReportCheckFailedStdout`.

**Note:** If the module for the report function is inserted into the project, the module should not be compiled with any C-RUN source code options.

The output from `__iar_ReportCheckFailedStdout` is not in user-readable form, because it only contains the raw data. You can use `cspybat` with the simulator driver to transform the raw text into something very similar to normal C-RUN messages. For more information, see *--rtc\_raw\_to\_txt*, page 387.

Use the option `--rtc_enable` to enable C-RUN in `cspybat`. Note that all `cspybat` options for C-RUN all begin with `--rtc_*`. For more information about these options, see *cspybat options for C-RUN*, page 386.

## REQUIREMENTS FOR RUNTIME ERROR CHECKING

To perform runtime error checking you need C-RUN, which is an add-on product to IAR Embedded Workbench.

---

## Using C-RUN

These tasks are covered:

- Getting started using C-RUN runtime error checking
- Creating rules for messages

### GETTING STARTED USING C-RUN RUNTIME ERROR CHECKING

Typical use of C-RUN involves these steps:

- Determine which C-RUN checks that are needed and specify them in the C-RUN options.
- Run your application in the IAR Embedded Workbench IDE and interactively inspect each C-RUN message. For each message, determine if it is the result of a real problem or not. If not, you can apply a rule to ignore that particular message, or similar messages in the future. If the message is the result of a real problem, you might, depending on the particular circumstances, need to correct the problem and rerun, or you might check for other problems first.
- When finished, close C-SPY. Because the C-RUN windows stay open, now is the time to work through the found problems. Look at the rules setup, possibly edit it, and then save it for future runs.
- Repeat the process until all problems are taken care of.

More in detail, to perform runtime error checking and detect possible runtime errors, follow this example of a typical process:

- 1 To set project options for runtime checking, choose **Project>Options>Runtime Checking** and select the runtime checks you want to perform, for example **Bounds checking**.

Note that runtime checking must be enabled on the project level, then you must enable each type of check you want to use. Some of the check options, such as **Use checked heap**, and **Enable bounds checking**, must be enabled on the project level, whereas others can be enabled on project or file level.

- 2 Build your application. Note that the lower optimization levels give you better information.
- 3 Start a debug session.
- 4 Start executing your application program.

- 5 If C-RUN detects a possible error, the program execution stops and the corresponding source code is highlighted in the editor window:

```
char *p = malloc(10);
free(p + 200);
iar_check_leaks(); // Leakage
return 0;
```

The **C-RUN Messages** window is displayed if it is not already open, and it provides information about the source code construct, type of check, and the call stack information for the source location

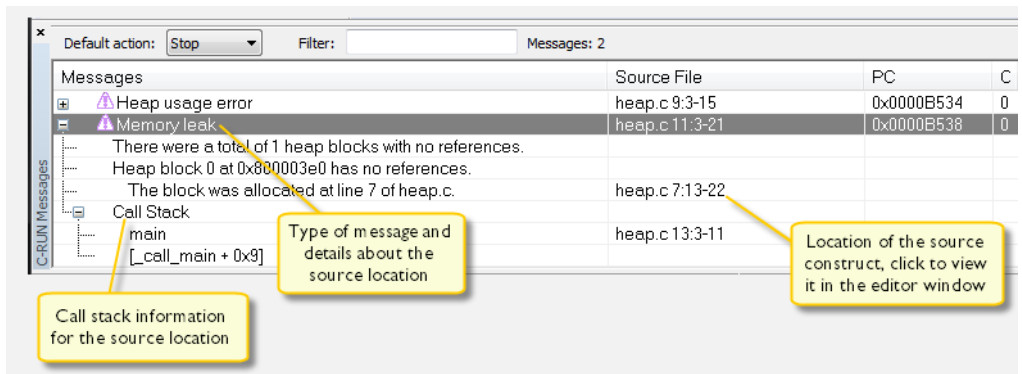

Note that detection of a problem might not occur at the actual point of access. The check might have been moved out of a loop, or several checks for different accesses might have been merged. In these cases, the problem source (the source for the problem access) might not be in the current statement, and there might be more than one problem source.

- 6 Depending on the source code construct, you might be able to continue program execution after the possible error has been detected. Note that some types of errors might cause unexpected behavior during runtime because of, for example, overwritten data or code.
- 7 If required, use the **C-RUN Messages Rules** window to specify rules to filter out specific messages based on specific checks and source code locations, specific checks and source files, or specific checks only. You can also specify whether a specific check should not stop the execution, but only log instead. See *Creating rules for messages*, page 355.

You can repeat this procedure for the various runtime checks you want to perform.

## CREATING RULES FOR MESSAGES

Depending on your source code, the number of messages in the **C-RUN Messages** window might be very large. For better focus, you can create rules to control which messages you want to be displayed.

### To create a rule:

- 1 Select a message in the **C-RUN Messages** window that you want to create a filter rule for.
- 2 Right-click and choose one of the rules from the context menu.  
The rule will appear in the **C-RUN Rules** window.
- 3 For an overview of all your rules, choose **View>C-RUN Rules**.

When a check fails, the rules determine how the message should be reported. Rules are scanned top–down and the action from the first matching rule is taken.

**Note:** You can save a filter setup and then load it later in a new debug session.

---

## Detecting various runtime errors

These tasks are covered:

- Detecting implicit or explicit integer conversion
- Detecting signed or unsigned overflow
- Detecting bit loss or undefined behavior when shifting
- Detecting division by zero
- Detecting unhandled cases in switch statements
- Detecting accesses outside the bounds of arrays and other objects
- Detecting heap usage error
- Detecting heap memory leaks
- Detecting heap integrity violations

### Detecting implicit or explicit integer conversion

Description	Checks that an integer conversion (implicit or explicit) or a write access to a bitfield does not change the value.
Why perform the check	Because C allows converting larger types to smaller integer types, some conversions can unintentionally remove significant bits of the value. The check can be limited to implicit

integer conversions, which is useful when the loss of data caused by explicit conversion is considered intentional.

#### How to use it

Compiler option:

```
--runtime_checking integer_conversion|implicit_integer_conversion
```

In the IDE: **Project>Options>Runtime Checking>Integer conversion**

The check can be applied to one or more modules.

The check can be avoided by inserting an explicit mask:

```
short f(int x)
{
    return x & 0xFFFF; /* Will not report change of value */
}
```

#### How it works

The compiler inserts code to perform the check at each integer conversion and at each write access to a bitfield, unless the compiler determines that the check cannot fail. Note that an explicit conversion from a constant will not be checked.

Note that increment/decrement operators (`++/--`) and compound assignments (`+=, -=, etc`) are checked as if they were written longhand (`var = var op val`).

For example, both `++i` and `i += 1` are checked as if they were written `i = i + 1`. In this case, the addition will be checked if overflow checks are enabled, and the assignment will be checked if conversion checks are enabled. For integer types with the same size as `int` or larger, the conversion check cannot fail. But for smaller integer types, any failure in an expression of this kind will generally be a conversion failure. This example shows this:

```
signed char a = 127;
void f(void)
{
    ++a; /* Conversion check error (128 -> -128) */
    a -= 1; /* Conversion check error (-129 -> 127) */
}
```

The code size increases, which means that if the application has resource constraints this check should be used module per module to minimize the overhead.

#### Example

Follow the procedure described in *Getting started using C-RUN runtime error checking*, page 353, but use the **Integer conversion** option.



This is an example of source code that will be identified during runtime:

```
int i = 5, j = 0;
char ch = 0;

void conv(void)
{
    ch = i * 100;
}
```

C-RUN will report either `Integer conversion failure` or `Bitfield overflow`. This is an example of the message information that will be listed:

Messages	Source File
<ul style="list-style-type: none"> <li>Integer conversion failure</li> <li>Conversion changes the value from 500 (0x000001f4)</li> <li>to 244 (0x4).</li> </ul>	arith.c 12:8-14
<ul style="list-style-type: none"> <li>Call Stack</li> <li>conv</li> <li>main</li> <li>[_call_main + 0x9]</li> </ul>	<ul style="list-style-type: none"> <li>arith.c 12:3-15</li> <li>arith.c 27:3-8</li> </ul>

## Detecting signed or unsigned overflow

Description	<p>Checks that the result of an expression is in the range of representable values for its type, and that shift counts are valid.</p> <p>Does not check for overflow in shift operations, which is handled by a separate check. See <i>Detecting bit loss or undefined behavior when shifting</i>, page 359.</p>
Why perform the check	<p>Because the behavior of signed overflow is undefined, and because unsigned overflow results in a truncation that can sometimes be undesirable. Although the shift operation is not checked, shift counts are checked because if a shift count is negative or greater than or equal to the width of the promoted left operand, the behavior of the shift operation is undefined.</p>
How to use it	<p>Compiler option:</p> <pre>--runtime_checking signed_overflow unsigned_overflow</pre> <p>In the IDE: <b>Project&gt;Options&gt;Runtime Checking&gt;Integer overflow</b></p> <p>The check can be applied to one or more modules.</p> <p>The check can be avoided, for example by working in a larger type, when such a type exists:</p> <pre>int f(int a, int b) { return (int) ((long long) a + (long long) b); } short g(short a, short b) { return (short) ( a + b); } /* Integer promotion occurs */</pre>

### How it works

The compiler inserts code to perform the check at each integer operation that can overflow (+, -, \*, /, %, including unary -) and each shift operation, unless the compiler determines that the check cannot fail.

Note that increment/decrement operators (++/--) and compound assignments (+=, -=, etc) are checked as if they were written longhand (`var = var op val`).

For example, both `++i` and `i += 1` are checked as if they were written `i = i + 1`. In this case, the addition will be checked if overflow checks are enabled, and the assignment will be checked if conversion checks are enabled. For integer types with the same size as `int` or larger, the conversion check cannot fail. But for smaller integer types, any failure in an expression of this kind will generally be a conversion failure. This example shows this:

```
signed char a = 127;
void f(void)
{
    ++a;    /* Conversion check error (128 -> -128) */
    a -= 1; /* Conversion check error (-129 -> 127) */
}
```

The code size increases, which means that if the application has resource constraints this check should be used per module to minimize overhead.

### Example

Follow the procedure described in *Getting started using C-RUN runtime error checking*, page 353, but use the **Integer overflow** option.

This is an example of source code that will be identified during runtime:

```
unsigned long ovfl(void)
{
    unsigned long ul = i + 0x7fffffff;
    return ul;
}
```

C-RUN will report either Signed integer overflow, Unsigned integer overflow, or Shift count overflow. This is an example of the message information that will be listed:

Messages	Source File
<ul style="list-style-type: none"> <li>Signed integer overflow</li> <li>Result is greater than the largest representable number: 5 (0x5) + 2147483647 (0x7fffffff).</li> </ul>	arith.c 26:22-35
<ul style="list-style-type: none"> <li>Call Stack</li> <li>ovfl</li> <li>main</li> <li>[_call_main + 0x9]</li> </ul>	<ul style="list-style-type: none"> <li>arith.c 26:17-36</li> <li>arith.c 35:3-8</li> </ul>

## Detecting bit loss or undefined behavior when shifting

Description	Checks for overflow in shift operations and that shift counts are valid.
Why perform the check	<p>Because the behavior of signed overflow is undefined, and because unsigned overflow results in a truncation that can sometimes be undesirable.</p> <p>Overflow occurs in a left shift operation <math>E1 \ll E2</math> if <math>E1</math> is negative or if the result, defined as <math>E1 * 2^{E2}</math>, is not in the range of representable values for its type.</p>
How to use it	<p>Compiler option: <code>--runtime_checking signed_shift unsigned_shift</code></p> <p>In the IDE: <b>Project&gt;Options&gt;Runtime Checking&gt;Integer shift overflow</b></p> <p>The check can be applied to one or more modules.</p> <p>The check can be avoided by masking before shift:</p> <pre>/* Cannot overflow */ int f(int x) { return (x &amp; 0x00007FFF) &lt;&lt; 16; }</pre>
How it works	<p>The compiler inserts code to perform the check for each shift operation, unless the compiler determines that the check cannot fail.</p> <p>The code size increases, which means that if the application has resource constraints this check should be used per module to minimize the overhead.</p>
Example	<p>Follow the procedure described in <i>Getting started using C-RUN runtime error checking</i>, page 353, but use the <b>Integer shift overflow</b> option.</p> <p>This is an example of source code that will be identified during runtime:</p>

```
void shift(void)
{
    i <<= 31;
}
```

C-RUN will report either `Shift overflow` or `Shift count overflow`. This is an example of the message information that will be listed:

Messages	Source File
 Shift overflow Result is greater than the largest representable number: signed value 5 (0x5) doubled 31 time(s). Call Stack shift main [_call_main + 0x9]	arith.c 32:3-10    arith.c 32:3-11 arith.c 41:3-9

## Detecting division by zero

Description	Checks for division by zero and modulo by zero. Floating-point operations are checked for division by exactly (positive) zero.
Why perform the check	Because the behavior of integer division by zero is undefined, and because floating-point division by exactly zero usually indicates a problem.
How to use it	<p>Compiler option: <code>--runtime_checking div_by_zero</code></p> <p>In the IDE: <b>Project&gt;Options&gt;Runtime Checking&gt;Division by zero</b></p> <p>The check can be applied to one or more modules.</p>
How it works	The compiler inserts code to perform the check at each division and modulo operation, unless the compiler determines that the check cannot fail.
Example	<p>Follow the procedure described in <i>Getting started using C-RUN runtime error checking</i>, page 353, but use the <b>Division by zero</b> option.</p> <p>This is an example of source code that will be identified during runtime:</p>

```
void div(void)
{
    j = i / j;
}
```

C-RUN will report *Division by zero*. This is an example of the message information that will be listed:

Messages	Source File
<ul style="list-style-type: none"> <li>▲ Division by zero</li> <li>Division by zero.</li> <li>Call Stack                             <ul style="list-style-type: none"> <li>div</li> <li>main</li> <li>[_call_main + 0x9]</li> </ul> </li> </ul>	<ul style="list-style-type: none"> <li>arith.c 7:7-11</li> <li>arith.c 7:3-12</li> <li>arith.c 37:3-7</li> </ul>

## Detecting unhandled cases in switch statements

Description	Checks for a missing <code>case</code> label in a <code>switch</code> statement that does not have a default label.
Why perform the check	The check is useful, for example, to detect when an <code>enum</code> type has been augmented with a new value that is not yet handled in a <code>switch</code> statement.

**How to use it**

Compiler option: `--runtime_checking switch`

In the IDE: **Project>Options>Runtime Checking>Switch**

The check can be applied to one or more modules.

The check can be avoided by adding a `default` label.

**How it works**

The compiler inserts an implicit `default` label to perform the check in each `switch` statement that does not have a `default` label.

**Example**

Follow the procedure described in *Getting started using C-RUN runtime error checking*, page 353, but use the **Switch** option.

This is an example of source code that will be identified during runtime:

```
void sw(void)
{
    switch(ch)
    {
        case 0: i = 3; break;
        case 5: i = 2; break;
    }
}
```

C-RUN will report `Unhandled case in switch`. This is an example of the message information that will be listed:

Messages	Source File
<ul style="list-style-type: none"> <li>▲ Unhandled case in switch</li> <li>Switch to undefined case label.</li> </ul>	arith.c 17:3-12
<ul style="list-style-type: none"> <li>Call Stack</li> <li>sw</li> <li>main</li> <li>[_call_main + 0x9]</li> </ul>	<ul style="list-style-type: none"> <li>arith.c 22:1-1</li> <li>arith.c 39:3-6</li> </ul>

## Detecting accesses outside the bounds of arrays and other objects

**Description**

Checks that accesses through pointer expressions are within the bounds of the expected object. The object can be of any type and can reside anywhere—globally, on the stack, or on the heap.

**Why perform the check** The check is useful whenever your application reads or writes to locations it should not. For example:

```
int arr[10] = {0};
int f(int i)
{
    return arr[i];
}
int g(void)
{
    return f(20); /* arr[20 is out of bounds] */
}
```

**How to use it**

Compiler option: `--runtime_checking bounds`

In the IDE: **Project>Options>Runtime Checking>Enable bounds checking**

This will enable out-of-bounds checking globally. Note that there are suboptions that you can use to fine-tune the out-of-bounds checking globally and for each source file.

**How it works**

In code where pointer bounds are tracked:

- Each transfer of a pointer value also transfers the bounds for that pointer value.
- When a pointer is initialized to point to an object of some sort, the bounds of the pointer are set to the bounds of the object. If the object is an array, the bounds cover the entire array. If it is a single instance, the bounds cover the single instance.
- When a pointer is initialized to an absolute address, the pointer is assumed to point to a single object of the specified type. For example:

```
uint32_t * p = (uint_32_t *)0x100;
```

In this case, `p` will point to a 32-bit unsigned integer at address `0x100`, with the bounds `0x100` and `0x104`.

- A null pointer is given bounds that do not cover any access, in other words, an access through it is erroneous.
- When a pointer value is passed to a function as a parameter, the bounds are passed as extra, hidden, parameters.
- When a pointer value is returned from a function, the returned value and the bounds are passed in a `struct` as the actual return value.
- When a pointer value is stored in memory in such a way that it can be accessed via pointers, its bounds are stored in a global bounds table. Whenever the pointer value is accessed, the associated bounds in the global bounds table are retrieved as well. The size of the global bounds table can be changed using **Number of entries** (the linker option `--bounds_table_size number_of_records[:number_of_buckets] |(number_of_bytes)`).

- In other cases, the bounds are kept track of in extra local variables.
- All floating-point library functions will use the softfp interface.

For each access through a pointer expression, the calculated address and the calculated address plus the access size is checked against the bounds. If any of the two addresses are outside of the bounds, a C-RUN message is generated.

Functions that receive pointers in any parameters, or that return a pointer value, can exist in two variants, one with the bounds, and one without the bounds.

#### Resource usage

The bounds checking overhead can cause the application to no longer fit in the available ROM or RAM. There are some ways you can try to deal with this:

- Provided that your application does not use too many indirectly accessed pointers, you can shrink the global bounds table to reduce the amount of RAM used for it. See *--bounds\_table\_size*, page 380 (in the IDE, **Number of entries**).  
By default, 4-Kbyte entries that need about 190 Kbytes are used.
- You can turn off the actual bounds checks in some modules. This will reduce the amount of code added by instrumentation to some extent.
- You can turn off pointer bounds tracking in some modules. This will eliminate the increase in code size entirely in these modules, but will cause problems in the interface between the code that does track pointer bounds and the code that does not. See the next section for more information.

#### Non-checked code

Sometimes you cannot enable bounds checking in the entire application, for example if some part of the application is an externally built library, or is written in assembler. If you add any extra source code lines to make your code work for bounds checking, use the preprocessor symbol `__AS_BOUNDS__` to make the extra source code conditional. These are some cases you should consider:

- *Calling code that does not track bounds from code that does*

This only affects functions with pointers as parameters or as return types.

By using `#pragma no_bounds` or `#pragma default_no_bounds` on your declarations, you can specify that certain functions do not track pointer bounds. If you call such a function from code that does not track pointer bounds, no extra hidden parameters are passed, and any returned pointers are either considered “unsafe” (all checked accesses via such pointers generate errors) or “safe” (accesses via such pointers cannot fail), depending on whether the option **Check pointers from non-instrumented functions** has been used or not (compiler option `--ignore_uninstrumented_pointers`). If you wish to explicitly specify the bounds on such values, use the built in operator `__as_make_bounds`.

For example:

```
#pragma no_bounds
struct X * f1(void);
...
{
    struct X *px = f1();
    /* Set bounds to allow accesses to a single X struct.
       (If the pointer can be NULL, you must check for that.) */
    if (px)
        px = __as_make_bounds(px, 1);
    /* From here, any accesses via the pointer will be checked
       to ensure taht they are within the struct. */
}
```

- *Calling code that tracks bounds from code that does not*

If you call a function that tracks bounds, and which has pointers as parameters, or which returns a pointer, from code that does not track bounds, you will generally get an undefined external error when linking. To enable such calls, you can use `#pragma generate_entry_without_bounds` or the option **Generate functions callable from non-instrumented code** (compiler option `--generate_entries_without_bounds`) to direct the compiler to emit one or more extra functions that can be called from code that does not track bounds. Each such function will simply call the function with default bounds, which will be either "safe" (accesses via such pointers never generate errors) or "unsafe" (accesses via such pointers always generate errors) depending on whether the option **Check pointers from uninstrumented functions** (compiler option `--ignore_uninstrumented_pointers`) has been used or not.

If you want to specify more precise bounds in this case, use `#pragma define_without_bounds`.

You can use this pragma directive in two ways. If the function in question is only called from code that does not track pointer bounds, and the bounds are known or can be inferred from other parameters, there is no need for two functions, and you can simply modify the definition using `#pragma define_without_bounds`.

For example:

```
#pragma define_without_bounds
int f2(int * p, int n)
{
    p = __as_make_bounds(p, n); /* Give p bounds */
    ...
}
```

In the example, `p` is assumed to point to an array of `n` integers. After the assignment, the bounds for `p` will be `p` and `p + n`.

If the function can be called from both code that does track pointer bounds and from code that does not, you can instead use `#pragma define_without_bounds` to



define an extra variant of the function without bounds information that calls the variant with bounds information.

You cannot define both the variant without bounds and the variant with bounds in the same translation unit.

For example:

```
#pragma define_without_bounds
int f3(int * p, int n)
{
    return f3(__as_make_bounds(p, n), n);
}
```

In the example, `p` is assumed to point to an array of `n` integers. The variant of `f3` without extra bounds information defined here calls the variant of `f3` with extra bounds information ("`f3 [with bounds]`"), giving the pointer parameter bounds of `p` and `p + n`.

- *Global variables with pointers defined in code that does not track bounds*

These pointers will get either bounds that signal an error on any access, or, if the option **Check pointers from non-instrumented memory** (linker option `--ignore_uninstrumented_pointers`) is used when linking, bounds that never cause an error to be signaled. If you need more specific bounds, use `__as_make_bounds`.

For example:

```
extern struct x * gptr;
int main(void)
{
    /* Give gptr bounds with size N. */
    gptr = __as_make_bounds(gptr, N);
    ...
}
```

- *RTOS tasks*

The function that implements a task might get called with a parameter that is a pointer. If the RTOS itself is not tracking pointer bounds, you must use `__as_make_bounds` and `__as_make_bounds` to get the correct bounds information.

For example:

```
#pragma define_without_bounds
void task1(struct Arg * p)
{
    /* p points to a single Arg struct */
    p = __as_make_bounds(p, 1);
    ...
}
```

Some limitations:

- *Function pointers*

Sharing a function pointer between code that tracks bounds and code that does not can be problematic.

There is no difference in type between functions that track bounds, and functions that do not. Functions of both kinds can be assigned to function pointers, or passed to functions that take function pointer parameters. However, if a function whose signature includes pointers is called in a non-matching context (a function that tracks bounds from code that does not, or vice versa), things will not work reliably. In the most favorable cases, this will mean confusing bounds violations, but it can cause practically any behavior because these functions are being called with an incorrect number of arguments.

For things to work, you must ensure that all functions whose signature includes pointers, and which are called via function pointers, are of the right kind. For the simple case of call-backs from a library that does not track bounds, it will usually suffice to use `#pragma no_bounds` on the relevant functions.

- *K&R functions*

Do not use K&R functions. Use `--require_prototypes` and shared header files to make sure that all functions have proper prototypes. Note that in C `void f()` is a K&R function, while `f(void)` is not.

- *Pointers updated by code that does not track bounds*

Whenever a pointer is updated by code that does not set up new bounds for the pointer, there is a potential problem. If the new pointer value does not point into the same object as the old pointer value, the bounds will be incorrect and an access via this pointer in checked code will signal an error.

## Absolute addresses

If you use `#pragma location` or the `@` operator to place variables at absolute addresses, pointers to these variables will get correct bounds, just like pointers to any other variables.

If you use an explicit cast from an integer to a pointer, the pointer will get bounds assuming that it points to a single object of the specified type. If you need other bounds, use `__as_make_bounds`.

For example:

```
/* p will get bounds that assume it points to a single struct
   Port at address 0x1000. */
p = (struct Port *)0x1000;
/* If it points to an array of 3 struct you can add */
p = __as_make_bounds(p, 3);
```

## Example

Follow the procedure described in *Getting started using C-RUN runtime error checking*, page 353, but use the **Bounds checking** option.

This is an example of source code that will be identified during runtime:

```
int Arr[4] = { 0, 1, 2, 3};

int ArrI = 5;

int f(void)
{
    int i = Arr[ArrI + 1]; // Double fail global
    i += Arr[ArrI + 2];
    return i;
}
```

C-RUN will report either **Access out of bounds** or **Invalid function pointer**.

This is an example of the message information that will be listed:

Messages	Source File
<ul style="list-style-type: none"> <li>Access out of bounds           <ul style="list-style-type: none"> <li>Access outside pointer bounds:               <ul style="list-style-type: none"> <li>Access 0x80000038 - 0x80000040</li> <li>Bounds 0x80000020 - 0x80000030, int Arr[4];</li> </ul> </li> <li>Call Stack               <ul style="list-style-type: none"> <li>f                   <ul style="list-style-type: none"> <li>main                       <ul style="list-style-type: none"> <li>[_call_main + 0x9]</li> </ul> </li> </ul> </li> </ul> </li> </ul> </li> </ul>	file.c:9:11-23, file.c:3:5-7, file.c:9:7-24, file.c:29:8-10

## Detecting heap usage error

### Description

Checks that the heap interface—`malloc`, `new`, `free`, etc—is used properly by your application. The following improper uses are checked for:

- Using the incorrect deallocator—`free`, `delete`, etc—for an allocator—`malloc`, `new`, etc. For example:

```
char * p1 = (char *)malloc(23); /* Allocation using malloc. */
char * p2 = new char[23];      /* Allocation using new[]. */
char * p3 = new int;          /* Allocation using new. */
delete p1                     /* Error, allocated using malloc. */
free(p2);                     /* Error, allocated using new[]. */
delete[] p3;                  /* Error, allocated using new. */
```

- Freeing a heap block more than once.
- Trying to allocate a heap block that is too large.

### Why perform the check

To verify that the heap interface is used correctly.

### How to use it

Linker option: `--debug_heap`

In the IDE: **Project>Options>Runtime Checking>Use checked heap**

The checked heap will replace the normal heap for the whole application. The checked heap requires extra heap and stack resources. Make sure that your application has at least 10 Kbytes of heap and 4 Kbytes of stack.

The limit for how large a heap block can be at allocation is by default 1 Gbyte. The limit can be changed by the function:

```
size_t __iar_set_request_report_limit(size_t value);
```

The function returns the old limit. You can find the declaration of this function in `iar_dlmalloc.h`. For more information, see the *IAR C/C++ Development Guide for Arm*.

**How it works**

For any incorrect use of the heap interface, a message will be issued.

See also *The checked heap provided by the library*, page 351.

**Example**

Follow the procedure described in *Getting started using C-RUN runtime error checking*, page 353, but use the **Debug heap** option.

This is an example of source code that will be identified during runtime:

```
int main(void)
{
    char *p = malloc(10);
    free(p + 200);
    iar_check_leaks(); // Leakage
    return 0;
}
```

C-RUN will report either **Heap integrity violation** or **Heap usage error**. This is an example of the message information that will be listed:

Messages	Source File
<ul style="list-style-type: none"> <li>Heap usage error                             <ul style="list-style-type: none"> <li>The address 0x800004a8 does not appear to be the start of a h...</li> </ul> </li> </ul>	heap.c 9:3-15
<ul style="list-style-type: none"> <li>Call Stack                             <ul style="list-style-type: none"> <li>main</li> <li>[_call_main + 0x9]</li> </ul> </li> </ul>	heap.c 11:3-21

## Detecting heap memory leaks

**Description**

Checks for heap blocks without references at a selected point in your application.

**Why perform the check**

A leaked heap block cannot be used or freed, because it can no longer be referred to. Use this check to detect references to heap blocks and report blocks that are seemingly

unreferenced. Note that the leak detection cannot find all possible memory leak cases, a seemingly unreferenced heap block might actually be referenced and a seemingly referenced heap block might actually be leaked.

**Note:** The leak checker does not currently support multi-threaded environments. The leak checker works by scanning known RAM locations for references to heap blocks. The thread executing the leak check has information about its own stack, but not about the stack of other threads. The missing information can result in both false positives and false negatives.

#### How to use it

Linker option: `--debug_heap`

In the IDE: **Project>Options>Runtime Checking>Use checked heap**

The checked heap will replace the normal heap for the whole application. The checked heap requires extra heap and stack resources. Make sure that your application has at least 10 Kbytes of heap and 4 Kbytes of stack.

The leak detection check must be called manually. It can either be called at the exit of the application or it can be used for detecting leaked heap blocks between two source points. These functions are defined in `iar_dlmalloc.h`:

- `void __iar_leaks_ignore_all(void);`  
Use this function to mark all currently allocated heap blocks to be ignored in subsequent heap leakage checks.
- `void __iar_leaks_ignore_block(void *block);`  
Use this function to mark a specific allocated heap block to be ignored in subsequent heap leakage checks.
- `void __iar_check_leaks(void);`  
Use this function to check for leaks.

#### How it works

The checked heap will replace the normal heap for the whole application. The heap leakage algorithm has three phases:

- 1 Scans the heap and makes a list of all allocated heap blocks.
- 2 Scans the statically used RAM, the stack, etc for addresses in the heap. If the address matches one of the heap blocks in the list above, it is removed from the list.
- 3 Reports the remaining heap blocks in the list as leaked.

See *The checked heap provided by the library*, page 351.

#### Example

Follow the procedure described in *Getting started using C-RUN runtime error checking*, page 353, but use the **Debug heap** option.

This is an example of source code that will be identified during runtime:

```
char *p = malloc(10);
p = malloc(20);
iar_check_leaks();
return *p;
```

C-RUN will report Memory leak. This is an example of the message information that will be listed:

Messages	Source File
<ul style="list-style-type: none"> <li>Memory leak                             <ul style="list-style-type: none"> <li>There were a total of 1 heap blocks with no references.</li> <li>Heap block 0 at 0x2000c670 has no references.</li> <li>The block was allocated at line 185 of heap_leak1.c.</li> </ul> </li> </ul>	heap_leak1.c 188:3-21
<ul style="list-style-type: none"> <li>Call Stack                             <ul style="list-style-type: none"> <li>main</li> <li>[_call_main + 0x9]</li> </ul> </li> </ul>	heap_leak1.c 190:3-12

## Detecting heap integrity violations

### Description

Checks for various heap integrity violations. The check can either be manually triggered or can be set up to be triggered at regular intervals of use of the heap interface. Integrity problems that can be detected when you enable this check are:

- Destruction of the internal heap structure. Mostly, this is because a write access through a pointer expression is incorrect. Use out-of-bounds checking to try to locate the erroneous write access.
- Write accesses outside allocated memory, for example:

```
char * p = (char *)malloc(100); /* Memory is allocated. */
...
p[100] = ... /* This write access is out of bounds. */
```

A write access that is out-of-bounds of the heap block and that changes the guards in front of or after the heap block will be detected. Any other write accesses will not be detected.

- Write accesses to freed memory, for example:

```
char * p = (char *)malloc(...); /* Memory is allocated. */
...
free(p); /* Memory is freed. */
...
p[...] = ... /* Write access to freed memory. */
```

If the memory that contains the original `p` is allocated again before `p` is written to, this error will typically not be detected. By using the delayed free list (see below), this error can be found.

**Why perform the check** Use the checked heap if you suspect that your application, at some point, writes erroneously in the heap, for example by misusing a heap block.

**How to use it** Linker option: `--debug_heap`

In the IDE: **Project>Options>Runtime Checking>Use checked heap**

The checked heap will replace the normal heap for the whole application. The checked heap requires extra heap and stack resources. Make sure that your application has at least 10 Kbytes of heap and 4 Kbytes of stack.

For detecting heap integrity violations, you can use these functions which are defined in `iar_dlmalloc.h`:

- `size_t __iar_check_heap_integrity(void);`

Use this function to verify the integrity of the heap. If any corruptions are detected, they are reported. The return value is the number of found problems. There is a limit on the number of corruption errors that are reported. This limit can be changed by using the `__iar_set_integrity_report_limit` function. Execution is only stopped when the final message is generated. The default number of reported messages is 10. A call to `__iar_check_heap_integrity` is not guaranteed to return to the caller if the heap is corrupt.

- `size_t __iar_set_heap_check_frequency(size_t interval);`

Use this function to specify how often the periodic heap integrity checks are performed. By default, the periodic checks are turned off (`interval = 0`). If `interval` is a positive number, the integrity will be checked every `interval`:th heap operation where every call to `free/malloc/new/delete/realloc/etc` counts as one operation. The function returns the old interval, which means that the state can be restored if necessary. The heap check interval can be increased or turned off when trusted parts of your application program, and then be decreased when you run parts of your application that are likely to contain heap errors.

- `size_t __iar_set_delayed_free_size(size_t size);`

Use this function to specify the maximum size of the freed delay list. By default, the freed delay list is turned off (`size = 0`). This function has no effect on the actual size of the list, it only changes the maximum. The function returns the previous value so it can be restored if necessary.

The freed delay list can be used to try to find locations in your application that use a freed heap block. This can help you detect:

- Mixing up an old heap block pointer that has been freed with a new, freshly allocated heap block pointer. Because the freed delay list will delay the actual reuse of a freed heap block, the behavior of your application might change and you might be able to detect the presence of this kind of problem.

- Writes to already freed heap blocks. If a heap block is in the freed delay list, it will get specific content, different from when it is actually freed, and a heap integrity check can find those erroneous write accesses to the heap block.
- `size_t __iar_free_delayed_free_size(size_t count);`  
Use this function to make sure that at most `count` elements are present in the freed delay list. Superfluous elements are freed (the oldest ones change first). It has no effect on the maximum size of the list—it only changes the current number of elements. Calling this function has no effect if `count` is larger than the current size of the list. The function returns the number of freed elements.

### How it works

The checked heap will replace the normal heap for the whole application.

The *freed delay list* is a queuing mechanism for `free` calls. When calling `free`, or an equivalent memory operation that returns memory to the heap, the recently freed pointer is *queued* to be freed instead of actually *being* freed. If the maximum size of the delay list is exceeded, the oldest elements above the maximum size in the freed delay list are actually freed.

All errors that the checked heap reports, mention a heap block that is somehow corrupt. The checked heap cannot inform about who corrupted the heap block or when it was corrupted. You can use calls to the `__iar_debug_check_heap_integrity` function to verify the integrity during application execution and narrow down the list of potential candidates.

For example:

```
...
__iar_debug_check_heap_integrity(); /* Pre-check */
my_function(..., ..., ...);
__iar_debug_check_heap_integrity(); /* Post-check */
...
```

If the post-check reports problems that the pre-check does not, it is probable that `my_function` corrupted the heap.

The checked heap consumes resources:

- The checked heap requires more ROM space than the normal heap implementation
- All heap operations require more time in the checked heap
- Each heap block in the checked heap contains additional space for bookkeeping, which results in increased RAM usage for your application.

See *The checked heap provided by the library*, page 351.

### Example

Follow the procedure described in *Getting started using C-RUN runtime error checking*, page 353, but use the **Checked heap** option.



This is an example of source code that will be identified during runtime:

```
void check(void)
{
    char *p = malloc(10);
    p[11] = 1;
    iar_check_heap_integrity();
}
```

C-RUN will report Heap integrity violation. This is an example of the message information that will be listed:

Messages	Source File
Heap integrity violation 1 heap integrity errors were detected. Violation detected in heap block 1 at address 0x80000408. The block was allocated at line 7 of heap.c.	heap.c 10:3-30
Call Stack	
check	heap.c 11:1-1
main	heap.c 21:3-9
[_call_main + 0x9]	

## Reference information on runtime error checking

Reference information about:

- *C-RUN Runtime Checking options*, page 373
- *C-RUN Messages window*, page 376
- *C-RUN Messages Rules window*, page 378

## C-RUN Runtime Checking options

The C-RUN Runtime Checking options determine which checks to perform at runtime.

C-RUN Runtime Checking

Enable

Use checked heap

Enable bounds checking

**Instrumentation**

Track pointer bounds

Check accesses

Generate functions callable from non-instrumented code

Check pointers from non-instrumented functions

**Global bounds table**

Check pointers from non-instrumented memory

Number of entries:

**Insert checks for**

Integer overflow

Including unsigned

Integer conversion

Including explicit casts

Integer shift overflow

Including unsigned shifts

Division by zero

Unhandled switch case

See also *Using C-RUN*, page 353.

**Enable**

Enables runtime checking.

**Use checked heap**

Uses the checked heap, to detect heap usage errors.

**Enable bounds checking**

Checks for accesses outside the bounds of arrays and other objects. Available checks:

**Track pointer bounds**

Makes the compiler add code that tracks pointer bounds. If you want to check pointer bounds, you should enable **Check accesses** and then decide how instrumented code should interact with non-instrumented code:

**Check accesses** Inserts code for checking accesses via pointers.

**Generate functions callable from non-instrumented code** When **Track pointer bounds** is enabled, any functions that return or receive types that contain pointers are modified to also return/receive pointer bounds. Use this option to generate an extra entry for each such function, which can be called from unchecked code.

**Check pointers from non-instrumented functions** When **Track pointer bounds** is enabled, pointers that originate from functions that are not instrumented for bounds checking are by default given globally permissive bounds information. Use this option to identify these pointers—any accesses via such pointers will generate an error. In this way you can manually replace the globally permissive bounds information with valid counterparts, see *\_\_as\_get\_base*, page 385, *\_\_as\_get\_bound*, page 385, *\_\_as\_make\_bounds*, page 386.

If this option is not used and you do not specify valid bounds information, accesses via such pointers do not generate errors and might result in unnoticed incorrect runtime behavior.

### Check pointers from non-instrumented memory

When **Track pointer bounds** is enabled, each time a pointer is loaded from memory, its bounds are looked up in the global bounds table. If no entry is found in the table for this pointer, usually because the pointer was created by non-instrumented code, it is given globally permissive bounds. Use this option to identify such pointers—any accesses via such pointers will generate an error. In this way you can manually replace the globally permissive bounds information with valid counterparts, see `__as_get_base`, page 385, `__as_get_bound`, page 385, `__as_make_bounds`, page 386.

If this option is not used and you do not specify valid bounds information, accesses via such pointers do not generate errors and might result in unnoticed incorrect runtime behavior.

### Number of entries

The bounds checking system uses a separate table to track bounds for pointers in memory. Use this option to set the number of such bounds that can be tracked simultaneously. The table will use approximately 50 bytes per pointer.

## Insert checks for

Inserts checks for:

### Integer overflow

Checks for signed overflow in integer operations. Use **Including unsigned** to also check for unsigned overflow in integer operations.

### Integer conversion

Checks for implicit integer conversions resulting in a change of value. Use **Including explicit casts** to also check for explicit casts.

### Integer shift overflow

Checks for overflow in shift operations. Use **Including unsigned shifts** to also check for unsigned overflow in shift operations.

### Division by zero

Checks for division by zero.

### Unhandled switch case

Checks for unhandled cases in `switch` statements

## C-RUN Messages window

The **C-RUN Messages** window is available from the **View** menu.

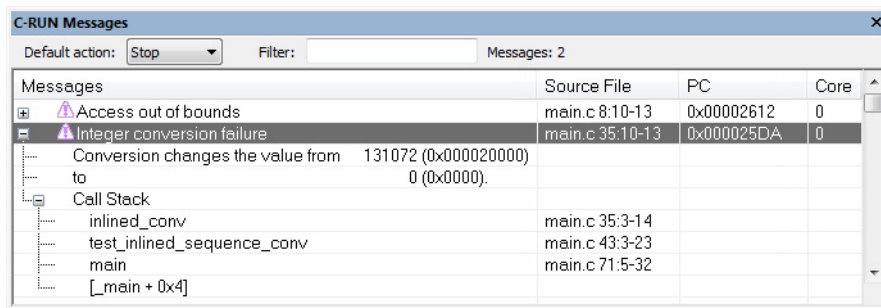

This window displays information about runtime errors detected by a runtime check. The window groups messages that have the same source statement, the same call stack, and the same messages.

See also *Using C-RUN*, page 353.

### Requirements

A license for the C-RUN product.

### Toolbar

The toolbar contains:

#### Default action

Sets the default action for what happens if no other rule is satisfied. Choose between **Stop**, **Log**, and **Ignore**.

#### Filter

Filters the list of messages so that only messages that contain the text you specify will be listed. This is useful if you want to search the message text, call stack entries, or filenames.

#### Messages

Lists the number of C-RUN messages.

## Display area

The display area shows all detected errors since the last reset. More specifically, the display area provides information in these columns:

### Messages

Information about the detected runtime error. Each message consists of a headline, detailed information about the error, and call stack information for the error location. Note that ranges displayed for accesses and bounds include the start address but not the end address.

### Source File

The name of the source file in which a runtime error was detected, or otherwise a relevant location, for example variable definitions.

### PC

The value of PC when the runtime error was detected.

### Core

The CPU core that executed the check, in case you have a multicore environment.

## Context menu

This context menu is available:

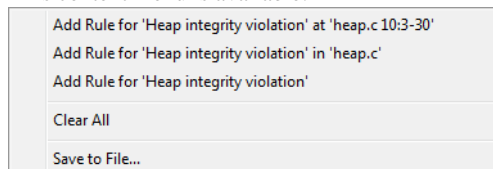

These commands are available:

### Add Rule for ... at *range*

Adds a rule that matches this particular runtime check at this particular location.

### Add Rule for ... in *filename*

Adds a rule that matches all runtime checks of this kind in the specified file.

### Add Rule for ...

Adds a rule that matches all runtime checks of this kind.

### Clear All

Clears the window from all content.

**Save to File**

Opens a dialog box where you can choose to save content to a file, either in text or XML format.

**C-RUN Messages Rules window**

The **C-RUN Messages Rules** window is available from the **View** menu.

Check	Source File	Action
Memory leak	heap.c 19:3-21	Ignore v
Heap usage error	heap.c 17:3-15	Ignore v
Heap usage error	heap.c 9:3-15	Ignore v
*	*	Stop v

This window displays the rules that control how messages are reported in the **C-RUN Messages** window. When a potential error is detected, it is matched against these rules (from top to bottom) and the action taken is determined by the first rule that matches. At the bottom, there is always a catch-all rule that matches all messages. This rule can be modified using **Default action** in the **C-RUN Messages** window.

\* is used as a wildcard.

See also *Using C-RUN*, page 353.

**Requirements**

A license for the C-RUN product.

**Display area**

The display area provides information in these columns:

**Check**

The name of the runtime error that this rule matches.

**Source File**

The name of the source file and possibly the location in the file to match.

**Action**

The action to take for errors that match the rule:

- **Stop** stops the execution and logs the error
- **Log** logs the error but continues the execution

- **Ignore** neither logs nor stops.

### Context menu

This context menu is available:

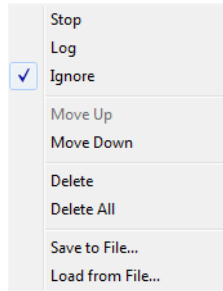

These commands are available:

#### Stop/Log/Ignore

Selects the action to take when a message matches the selected rule.

#### Move Up/Down

Moves the selected rule up/down one step.

#### Delete

Deletes the selected rule.

#### Delete All

Deletes all rules.

#### Save to File

Opens a dialog box where you can choose to save rules, see **Load from File**.  
See also `--rtc_rules`, page 388.

#### Load from File

Opens a dialog box where you can choose to load rules from a file.

---

## Compiler and linker reference for C-RUN

Reference information about:

- `--bounds_table_size`, page 380 (linker option)
- `--debug_heap`, page 381 (linker option)
- `--generate_entries_without_bounds`, page 381 (compiler option)
- `--ignore_uninstrumented_pointers`, page 381 (compiler option)

- `--ignore_uninstrumented_pointers`, page 382 (linker option)
- `--runtime_checking`, page 382 (compiler option)
- `#pragma default_no_bounds`, page 383
- `#pragma define_with_bounds`, page 383
- `#pragma define_without_bounds`, page 383
- `#pragma disable_check`, page 384
- `#pragma generate_entry_without_bounds`, page 384
- `#pragma no_arith_checks`, page 385
- `#pragma no_bounds`, page 385
- `__as_get_base`, page 385
- `__as_get_bound`, page 385
- `__as_make_bounds`, page 386

## **--bounds\_table\_size**

Syntax	<code>--bounds_table_size records[:buckets]   (bytes)</code>	
Parameters	<code>records</code>	The number of records.
	<code>:buckets</code>	The number of buckets.
	<code>(bytes)</code>	The number of bytes, within parentheses.
For use with	The linker.	
Description	<p>Use this linker option to specify the size of the global bounds table, which is used for tracking the bounds of pointers in memory.</p> <p>You can specify the number of records in the table (the number of pointers it can keep bounds for). If you do, you can also specify the number of buckets (a power of two), which will affect the speed of lookups. If not specified, the number of buckets is a power of two that is at least 6 times the number of records.</p> <p>Alternatively, you can specify the total number of bytes to use for records and buckets.</p>	
See also	<i>Detecting accesses outside the bounds of arrays and other objects</i> , page 361.	



**Project>Options>Runtime Checking>Number of entries**



## --debug\_heap

Syntax	--debug_heap
For use with	The linker.
Description	Use this linker option to use the checked heap.
See also	<i>The checked heap provided by the library</i> , page 351.
	 <b>Project&gt;Options&gt;Runtime Checking&gt;Use checked heap</b>

## --generate\_entries\_without\_bounds

Syntax	--generate_entries_without_bounds
For use with	The compiler.
Description	Use this compiler option to generate extra functions for use from non-instrumented code. This option requires that out-of-bounds checking is enabled.
See also	<i>Detecting accesses outside the bounds of arrays and other objects</i> , page 361.
	 <b>Project&gt;Options&gt;Runtime Checking&gt;Generate functions callable from non-instrumented code</b>

## --ignore\_uninstrumented\_pointers

Syntax	--ignore_uninstrumented_pointers
For use with	The compiler.
Description	Use this compiler option to disable checking of accesses via pointers from non-instrumented functions.
See also	<i>Detecting accesses outside the bounds of arrays and other objects</i> , page 361.
	 <b>Project&gt;Options&gt;Runtime Checking&gt;Check pointers from non-instrumented functions</b>

## --ignore\_uninstrumented\_pointers

Syntax	<code>--ignore_uninstrumented_pointers</code>
For use with	The linker.
Description	Use this linker option to disable checking of accessing via pointers in memory for which no bounds have been set.
See also	<i>Detecting accesses outside the bounds of arrays and other objects</i> , page 361.



**Project>Options>Runtime Checking>Check pointers from non-instrumented memory**

## --runtime\_checking

Syntax	<code>--runtime_checking param ,param, ...</code>														
Parameters	<p><i>param</i> is one of:</p> <table> <tr> <td><code>signed_overflow   unsigned_overflow</code></td> <td>Checks for signed or unsigned overflow in integer operations.</td> </tr> <tr> <td><code>integer_conversion   implicit_integer_conversion</code></td> <td>Checks for implicit or explicit integer conversions resulting in a change of value.</td> </tr> <tr> <td><code>div_by_zero</code></td> <td>Checks for division by zero.</td> </tr> <tr> <td><code>signed_shift   unsigned_shift</code></td> <td>Checks for bit loss or implementation-dependent results when shifting.</td> </tr> <tr> <td><code>switch</code></td> <td>Checks for unhandled cases in <code>switch</code> statements.</td> </tr> <tr> <td><code>bounds</code></td> <td>Checks for accesses outside the bounds of arrays and other objects.</td> </tr> <tr> <td><code>bounds_no_checks</code></td> <td>Tracks pointer bounds, but performs no checks. See also <code>#pragma disable_check = bounds</code>.</td> </tr> </table>	<code>signed_overflow   unsigned_overflow</code>	Checks for signed or unsigned overflow in integer operations.	<code>integer_conversion   implicit_integer_conversion</code>	Checks for implicit or explicit integer conversions resulting in a change of value.	<code>div_by_zero</code>	Checks for division by zero.	<code>signed_shift   unsigned_shift</code>	Checks for bit loss or implementation-dependent results when shifting.	<code>switch</code>	Checks for unhandled cases in <code>switch</code> statements.	<code>bounds</code>	Checks for accesses outside the bounds of arrays and other objects.	<code>bounds_no_checks</code>	Tracks pointer bounds, but performs no checks. See also <code>#pragma disable_check = bounds</code> .
<code>signed_overflow   unsigned_overflow</code>	Checks for signed or unsigned overflow in integer operations.														
<code>integer_conversion   implicit_integer_conversion</code>	Checks for implicit or explicit integer conversions resulting in a change of value.														
<code>div_by_zero</code>	Checks for division by zero.														
<code>signed_shift   unsigned_shift</code>	Checks for bit loss or implementation-dependent results when shifting.														
<code>switch</code>	Checks for unhandled cases in <code>switch</code> statements.														
<code>bounds</code>	Checks for accesses outside the bounds of arrays and other objects.														
<code>bounds_no_checks</code>	Tracks pointer bounds, but performs no checks. See also <code>#pragma disable_check = bounds</code> .														
For use with	The compiler.														
Description	Use this compiler option to enable runtime error checking.														

See also

*Introduction to runtime error checking*, page 349.



To set related options, choose:

**Project>Options>Runtime Checking**

## #pragma default\_no\_bounds

Syntax	<code>#pragma default_no_bounds [=on off]</code>	
Parameters	<code>on</code>	Makes the default for all functions declared from this point be as if they were declared with <code>#pragma no_bounds</code> .
	<code>off</code>	Turns off the default.
Description	Use this pragma directive to apply <code>#pragma no_bounds</code> to a whole set of functions, for example around a header file declaring the interface to unchecked code.	
See also	<i>Detecting accesses outside the bounds of arrays and other objects</i> , page 361.	

## #pragma define\_with\_bounds

Syntax	<code>#pragma define_with_bounds</code>	
Description	You can only use this pragma directive on a function that is declared with <code>#pragma no_bounds</code> (or equivalent). The function will then be instrumented to track pointer bounds, but not to perform any bounds checks. Any calls to the function will be to the version without extra bounds information.	
	This is useful for writing a checking version of a function based on the non-checking version.	

## #pragma define\_without\_bounds

Syntax	<code>#pragma define_without_bounds</code>	
Description	Use this pragma directive to define the version of a function that does not have extra bounds information. The code of the function is still instrumented to track pointer bounds (and checks are also inserted, unless <code>#pragma disable_check = bounds</code> is used).	

This can be useful for functions that are exclusively called from code that does not track pointer bounds, and where the bounds can be inferred from other arguments, or in some other way.

**Example**

```
/* p points to an array of n integers */
void fun(int * p, int n)
{
    /* Set up bounds for p. */
    p = __as_make_bounds(p, n);
    ...
}
```

**#pragma disable\_check****Syntax**

```
#pragma disable_check = bounds
```

**Parameters**

bounds

Does not check accesses against bounds.

**Description**

Use this pragma directive to specify that the immediately following function does not check accesses against bounds. If compiled with bounds checking, the function will be instrumented to track bounds, but will perform no checks.

**#pragma generate\_entry\_without\_bounds****Syntax**

```
#pragma generate_entry_without_bounds
```

**Description**

Use this pragma directive to enable generation of an extra entry without bounds for the immediately following function. This extra entry (function) can be called from code which is not instrumented for bounds checking. It takes no extra hidden parameters, and does not add any information about bounds for returned pointers. Any pointers passed into such a function are given bounds that will cause an error for any access. If you use `--ignore_uninstrumented_pointers`, the given bounds will not cause errors.



It is an error to use this pragma directive on a function where no such entry can be generated. This includes functions that take a variable number of arguments, and functions that take one or more function pointers to functions that take or return values that contain pointers.

It is not an error to use this pragma directive on a function that does not need such an entry (because it takes no pointers, or because it is declared with `#pragma no_bounds`). In this case, no extra entry is generated.

See also *Detecting accesses outside the bounds of arrays and other objects*, page 361.

## #pragma no\_arith\_checks

Syntax	<code>#pragma no_arith_checks</code>
Description	Use this pragma directive to specify that no C-RUN arithmetic checks will be performed in the function that follows.

## #pragma no\_bounds

Syntax	<code>#pragma no_bounds</code>
Description	Use this pragma directive to specify that the immediately following function is not instrumented for bounds checking. No extra hidden bounds parameters will be passed when this function is called, and it will not return bounds for pointers, if any, in its return value.

See also *Detecting accesses outside the bounds of arrays and other objects*, page 361.

## \_\_as\_get\_base

Syntax	<code>__as_get_base(ptr)</code>
Parameters	<i>ptr</i> A pointer.
Description	Use this operator to create a pointer of the same type as <i>ptr</i> , representing the base of the area pointed to by <i>ptr</i> .
Example	<code>base = __as_get_base(my_ptr);</code>

## \_\_as\_get\_bound

Syntax	<code>__as_get_bound(ptr)</code>
Parameters	<i>ptr</i> A pointer.

**Description** Use this operator to create a pointer of the same type as *ptr*, representing the upper bound of the area pointed to by *ptr*.

**Example** `bound = __as_get_bound(my_ptr);`

## **`__as_make_bounds`**

**Syntax** `__as_make_bounds(ptr, number)`  
`__as_make_bounds(ptr, base, bound)`

**Parameters**

<i>ptr</i>	A pointer that has no bounds.
<i>number</i>	The number of elements.
<i>base</i>	The start of the object pointed to.
<i>bound</i>	The end of the object pointed to.

**Description** Use this operator to create a pointer with bounds information. Use the first syntax to create the bounds *ptr* up to *ptr + size* for *ptr*. The second syntax has explicit bounds. *base* is a pointer to the first element of the area. *bound* is a pointer to just beyond the area. Except that each expression will be evaluated only once, the two-parameter variant is equivalent to `__as_make_bounds(ptr, ptr, ptr + size)`.

**Example**

```
/* Starting here, p points to a single element */
p = __as_make_bounds(p, 1);
/* Call fun with a pointer with the specified bounds */
fun(__as_make_bounds(q, start, end));
```

---

## **cspybat options for C-RUN**

Reference information about:

- `--rtc_enable`, page 387
- `--rtc_output`, page 387
- `--rtc_raw_to_txt`, page 387
- `--rtc_rules`, page 388

**--rtc\_enable**

Syntax `--rtc_enable`

Note that this option must be placed before the `--backend` option on the command line.

For use with `cspybat`

Description Use this option to enable C-RUN run-time checking in `cspybat`. This option is automatically enabled if any of the other `-rtc_*` options are used.



This option is not available in the IDE.

**--rtc\_output**

Syntax `--rtc_output file`

Note that this option must be placed before the `--backend` option on the command line.

Parameters *file* The file for output messages.

For use with `cspybat`

Description Use this option to specify to `cspybat` a file for the C-RUN message output, in text (filename extension `txt`) or XML (filename extension `xml`) format.



This option is not available in the IDE.

**--rtc\_raw\_to\_txt**

Syntax `--rtc_raw_to_txt=file`

Note that this option must be placed before the `--backend` option on the command line.

For use with `cspybat`

Description Use this option to make `cspybat` act as a runtime checking messages filter. The option reads a file and transforms each message into a properly formatted message (as in the **C-RUN Messages** window). The only limitation is that call stack information cannot be provided.



This option is not available in the IDE.

## **--rtc\_rules**

Syntax

```
--rtc_rules file
```

Note that this option must be placed before the `--backend` option on the command line.

Parameters

*file*                      The rules input file.

For use with

`cspybat`

Description

Use this option to specify the name of the C-RUN rules file to `cspybat`.

See also

*C-RUN Messages Rules window*, page 378 for information about **Save to File**.



This option is not available in the IDE.



# Part 3. Advanced debugging

This part of the *C-SPY® Debugging Guide for Arm* includes these chapters:

- Multicore debugging
- Interrupts
- C-SPY macros
- The C-SPY command line utility—`cspybat`
- Flash loaders

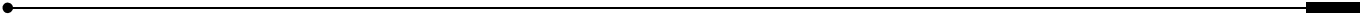
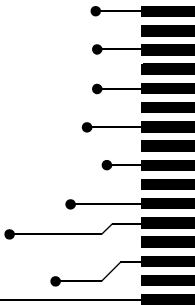

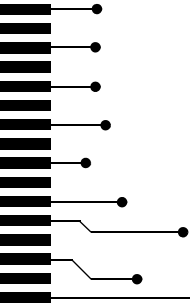

# Multicore debugging

- Introduction to multicore debugging
- Debugging multiple cores
- Reference information on multicore debugging

---

## Introduction to multicore debugging

These topics are covered:

- Briefly about multicore debugging
- Symmetric multicore debugging
- Asymmetric multicore debugging
- Requirements and restrictions for multicore debugging

### BRIEFLY ABOUT MULTICORE DEBUGGING

Multicore debugging means that you can debug targets with multiple cores. The C-SPY debugger supports multicore debugging in two ways:

- *Symmetric multicore debugging (SMP)*, which means debugging two or more identical cores that run the same application. This is handled using a single instance of the IAR Embedded Workbench IDE.
- *Asymmetric multicore debugging (AMP)*, which means debugging two or more cores that run separate applications. This is handled using two or more cooperating instances of the IAR Embedded Workbench IDE, where each instance is connected to one or more identical cores.

### SYMMETRIC MULTICORE DEBUGGING

Symmetric multicore debugging means that the target has two or more identical cores that run the same application. The cores can typically be accessed through a single debug probe.

In the debugger, at any given time the windows show the state of only one of the cores—the one in focus.

This is an overview of special support for symmetric multicore debugging:

- You can control whether to automatically start and stop the whole application or to run the cores independently of each other.

- You can also control which core you want the debugger to focus on. This affects editor windows and the **Disassembly, Registers, Watch, Locals, Call Stack** window, etc.
- The **Cores** window shows a list of all available cores, and gives some information about each core, such as its execution state. The **Multicore** toolbar is a complement to the **Cores** window,
- The **Stack** window can show the stack for each core by means of dedicated stack sections.
- RTOS support is available in separate multicore-aware plugins. Typically, they work like their single-core plugin counterparts, but handle multiple active tasks on separate cores. The plugins might also provide the information required by the **Stack** window to display the stack for any selected task.

## ASYMMETRIC MULTICORE DEBUGGING

Asymmetric multicore means that the target has two or more cores that run separate applications. To debug the target, two or more IDE instances can be used, where each instance is connected to one or more identical cores. The IDE instances synchronize so that debugging sessions can be started and stopped, and the cores can be controlled from any of the instances. Except for shared memory, each debugging session can only show information (variables, call stack, etc) about its own cores.

You start one IDE instance manually and that instance is referred to as the *master*. When you start an asymmetric multicore debugging session, the *master* instance can initiate one or more *partner* (or *slave*) instances. The partner instances will be reused if they are already running.

All instances each require their own project, master and partners. You must set up each project with the correct processor variant, linker, and debugger options. The master project must also be configured to act as multicore master or have multicore master mode enabled.

One possible strategy for download is to combine the debug images for the cores into one and let the master project download the combined image. In this scenario, the partners must be configured to attach to a running target, and/or to suppress any downloading.

Another strategy is to download the master and partners as separate binary images, in which case you must make sure to avoid any unintentional overlaps in memory.

This is an overview of special support for asymmetric multicore debugging:

- You can control whether to automatically start and stop the whole application or to run the cores independently of each other.

- Each instance of the IDE displays debug information for the cores that it is connected to.
- The **Cores** window shows a list of all available cores, and gives some information about each core, such as its execution state. The **Multicore** toolbar is a complement to the **Cores** window,
- When you set a breakpoint, it is only connected to one core, and when the breakpoint is triggered, that core is stopped.

## REQUIREMENTS AND RESTRICTIONS FOR MULTICORE DEBUGGING

The C-SPY simulator supports multicore debugging for most cores and devices. If supported, there are no further specific requirements or restrictions.

To use multicore debugging in your hardware debugger system, you need a specific combination of C-SPY driver and debug probe:

- The IAR C-SPY I-jet driver
- The IAR C-SPY CMSIS-DAP driver
- The IAR C-SPY J-Link/J-Trace driver (asymmetric multicore)

**Note:** There might be restrictions in trace support due to limitations in the hardware you are using.

---

## Debugging multiple cores

These tasks are covered:

- Setting up for symmetric multicore debugging
- Setting up for asymmetric multicore debugging
- Starting and stopping a multicore debug session

### SETTING UP FOR SYMMETRIC MULTICORE DEBUGGING

- 1 Choose **Project>Options>Debugger>Multicore** and specify the number of cores you have.
- 2 You can now start your debug session.

### SETTING UP FOR ASYMMETRIC MULTICORE DEBUGGING

There are a number of ways that you can set up for multicore debugging, but this strategy is recommended:

## 1: Preparing the projects

- 1 Create a workspace with two or more projects, one for each core or set of cores.
- 2 Select an appropriate download strategy. One possible download strategy would be to combine the images for the cores into one and let the master project download the combined image. In this scenario, the partners would have to be configured to attach to a running target, and/or to suppress any downloading.
- 3 In the intended master project, choose **Project>Options>Debugger>Multicore** to open the **Multicore** options page.

### 2A: Setting up one partner project

- 1 Select **Simple**. Specify the options **Partner workspace** (path), **Partner project** (project name), and **Partner configuration** (build configuration). These settings are used when the partner session starts.

The screenshot shows the 'Multicore' options dialog. It is divided into two sections: 'Symmetric multicore' and 'Asymmetric multicore'.  
 - In the 'Symmetric multicore' section, there is a text box for 'Number of cores' containing the value '1'.  
 - In the 'Asymmetric multicore' section, there are three radio buttons: 'Disabled', 'Simple' (which is selected), and 'Advanced'.  
 - Below the 'Simple' radio button, there are four text boxes with ellipsis buttons: 'Partner workspace' (C:\Temp\MyWorkspace.eww), 'Partner project' (MyProject), 'Partner configuration' (Debug), and 'Partner debugger' (C:\Program Files\IAR Systems\Embed).  
 - There are two checked checkboxes: 'Attach partner to running target' and 'Override partner debugger location'.  
 - Next to the 'Attach partner to running target' checkbox is a text box for 'Partner cores' containing the value '2'.  
 - At the bottom of the 'Asymmetric multicore' section, there is a text box for 'Session configuration' which is currently empty.

- 2 Select the option **Attach partner to running target**. Use the **Partner cores** option to specify the number of cores in the partner project.

By default, the Embedded Workbench instance associated with the *partner* project must be installed in the same directory as the Embedded Workbench instance associated with the *master* project, for example in `c:\Program Files\IAR Systems\Embedded Workbench N.n`. If the two Embedded Workbench instances were installed in *different* locations (perhaps because they are not based on the same version (*N.n*) of the Embedded Workbench shared components), you must select **Override partner debugger location** and specify the installation directory of the Embedded Workbench for the partner project. Note that the Embedded Workbench for the partner project must

be based on version 9.1.7 or later of the shared components—to check this, choose **Help>About>Product Info**.

For more information about the multicore settings, see *Multicore*, page 588

## 2B: Setting up two or more partner projects

- 1 Select **Advanced**. Create a multicore session file in XML format with information about location and settings of the partner projects and use the browse button to specify this file. For more information about this file, see *The multicore session file*, page 399. These settings are used when the partner session starts.

The image shows a dialog box titled "Multicore" with two sections: "Symmetric multicore" and "Asymmetric multicore".

- Symmetric multicore:** "Number of cores:" is set to 1.
- Asymmetric multicore:**
  - Radio buttons: "Disabled" is unselected, "Simple" is selected.
  - Fields: "Partner workspace:", "Partner project:", and "Partner configuration:" are empty.
  - Checkboxes: "Attach partner to running target" and "Override partner debugger location" are unchecked.
  - Field: "Partner cores:" is set to 2.
  - Field: "Partner debugger:" is empty.
  - Radio buttons: "Advanced" is selected.
  - Field: "Session configuration:" is set to "C:\Temp\SessionSpec.xml".

## 3: Make final settings

- 1 Select appropriate reset strategies for all projects:
  - In the master project, choose **Project>Options>C-SPY driver>Setup>Reset** and select a reset strategy, typically **Hardware**.
  - In the **Workspace** window, switch to the partner projects one at a time. Then for each project, choose **Project>Options>C-SPY driver>Setup>Reset** and select a reset strategy *for the partner session* that does not affect the master session, typically **Software**.
- 2 Make sure to use compatible settings for the debug probe for all projects.

The master and partner instances are indicated in the main IDE window title bar.

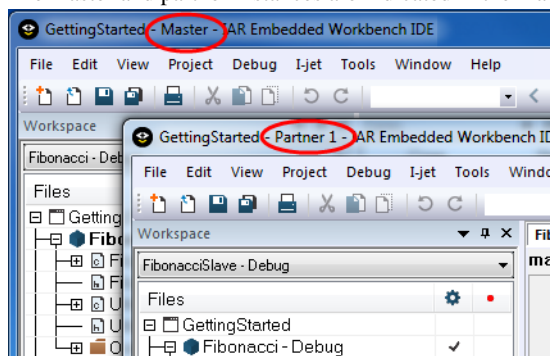

## STARTING AND STOPPING A MULTICORE DEBUG SESSION

- 1 To start a multicore debug session, for example use the standard **Download and Debug** command, either in the master or in a partner session.
- 2 To stop a multicore debug session, for example use the standard **Stop Debugging** command, which will stop all debugging sessions.

---

## Reference information on multicore debugging

Reference information about:

- *Cores window*, page 397
- *Multicore toolbar*, page 399
- *The multicore session file*, page 399

See also:

- *\_\_getNumberOfCores*, page 459
- *\_\_getSelectedCore*, page 459
- *\_\_selectCore*, page 485



## Cores window

The **Cores** window is available from the **View** menu.

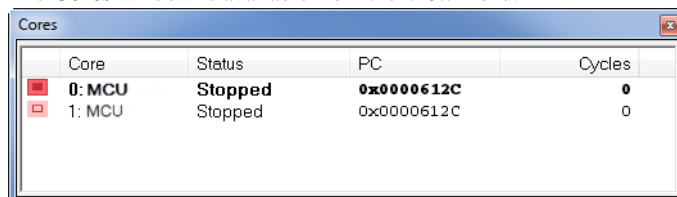

This window shows a list of all available cores, and gives some information about each core, such as its execution state. The line highlighted in bold is the core currently in focus, which means that any window showing information that is specific to a core will be updated to reflect the state of the core in focus. This includes highlights in editor windows and the **Disassembly**, **Registers**, **Watch**, **Locals**, **Call Stack** window, and so on. Double-click a line to focus on that core.

**Note:** For asymmetric multicore debugging, only local cores can be in focus.

If both cores are executing, and either one of them hits a breakpoint (or some other condition which causes the program execution to stop), then the debugger attempts to focus on that core automatically.

See also *Debugging multiple cores*, page 393.

### Requirements

One of these alternatives:





- An I-jet or I-jet Trace debug probe
- A J-Link or J-Trace debug probe
- The C-SPY simulator. (Not for all cores and devices.)

### Display area

A row in this area shows information about a core, in these columns:

#### *Execution state*

Displays one of these icons to indicate the execution state of the core:

	in focus, not executing
	not in focus, not executing
	in focus, executing
	not in focus, executing



in focus, unknown status



not in focus, unknown status

### Core

The name of the core.

### Status

The status of the execution, which can be one of **Stopped**, **Running**, **Sleeping**, or **Unknown**.

### PC

The value of the program counter.

### Cycles | Time

The value of the cycle counter or the execution time since the start of the execution, depending on the debugger driver you are using.

## Context menu

For symmetric multicore debugging, this context menu is available:

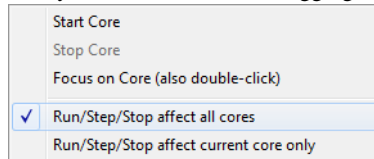

These commands are available:

### Start Core

Starts the selected core.

### Stop Core

Stops the selected core.

### Focus on Core (also double-click)

Focuses on the selected core.

### Run/Step/Stop affect all cores

The **Run**, **Step**, **Stop** commands affect all cores.

### Run/Step/Stop affect current core only

The **Run/Step/Stop** commands only affect the current core. This menu command is only supported if your device supports it.

**Note:** These commands are not supported by all target hardware.

## Multicore toolbar

The **Multicore** toolbar can be toggled on/off from the **Window>Toolbars** submenu when you have enabled multicore debugging, see *Setting up for symmetric multicore debugging*, page 393 or *Setting up for asymmetric multicore debugging*, page 393, respectively.

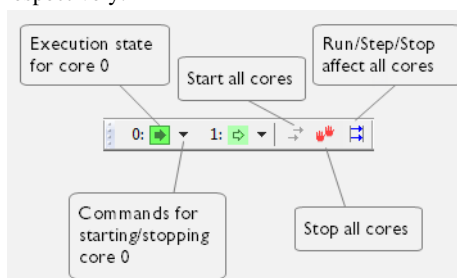

This toolbar is a complement to and shows the same state as the **Cores** window. Each core has a button with an adjacent drop-down menu. Click a button to make C-SPY focus on that core.

**Note:** For asymmetric multicore debugging, you can use the toolbar commands to start and stop cores in the associated debugging session.

## The multicore session file

This file in XML format can be used to specify an asymmetric debug session with more than two IDE instances. You specify the location of the file to the IDE on the **Project>Options>Debugger>Multicore** page. For more information, see *Setting up for asymmetric multicore debugging*, page 393, and *Multicore*, page 588,

### XML specification

The multicore session file needs to look like this:

```
<?xml version="1.0" encoding="utf-8"?>
<sessionSetup>
  <partner>
    <name>Name_of_master_instance</name>
    <workspace>Path_to_workspace</workspace>
    <project>Name_of_project</project>
    <config>Build_config</config>
    <numberOfCores>N</numberOfCores>
    <attachToRunningTarget>true/false</attachToRunningTarget>
  </partner>
</sessionSetup>
```

```
<partner>
  <name>Name_of_partner_instance_1</name>
  <workspace>Path_to_workspace</workspace>
  <project>Name_of_project</project>
  <config>Build_config</config>
  <numberOfCores>N</numberOfCores>
  <attachToRunningTarget>true/false</attachToRunningTarget>

  <debuggerpath>Path_to_Embedded_workbench</debuggerpath>
</partner>

...

<partner>
  <name>Name_of_partner_instance_N</name>
  <workspace>Path_to_workspace</workspace>
  <project>Name_of_project</project>
  <config>Build_config</config>
  <numberOfCores>N</numberOfCores>
  <attachToRunningTarget>true/false</attachToRunningTarget>

  <debuggerpath>Path_to_Embedded_workbench</debuggerpath>
</partner>

</sessionSetup>
```

# Interrupts

- Introduction to interrupts
- Using the interrupt system
- Reference information on interrupts

---

## Introduction to interrupts

These topics are covered:

- Briefly about the interrupt simulation system
- Interrupt characteristics
- Interrupt simulation states
- C-SPY system macros for interrupt simulation
- Target-adapting the interrupt simulation system
- Briefly about interrupt logging

See also:

- *Reference information on C-SPY system macros*, page 444
- *Breakpoints*, page 125
- *The IAR C/C++ Development Guide for Arm*

### **BRIEFLY ABOUT THE INTERRUPT SIMULATION SYSTEM**

By simulating interrupts, you can test the logic of your interrupt service routines and debug the interrupt handling in the target system long before any hardware is available. If you use simulated interrupts in conjunction with C-SPY macros and breakpoints, you can compose a complex simulation of, for instance, interrupt-driven peripheral devices.

For most cores and devices, the C-SPY Simulator includes an interrupt simulation system where you can simulate the execution of interrupts during debugging. You can configure the interrupt simulation system so that it resembles your hardware interrupt system. Note that for some cores and devices, the C-SPY simulator uses the Imperas Instruction Set Simulator instead of the IAR C-SPY simulator driver, see *The IAR C-SPY Simulator*, page 48. The Imperas Instruction Set Simulator does not support simulated interrupts. When C-SPY uses the Imperas driver, the interrupt system more resembles a hardware interrupt system.

The interrupt system has the following features:

- Simulated interrupt support for the Arm core
- Single-occasion or periodical interrupts based on the cycle counter
- Predefined interrupts for various devices
- Configuration of hold time, probability, and timing variation
- State information for locating timing problems
- Configuration of interrupts using a dialog box or a C-SPY system macro—that is, one interactive and one automating interface. In addition, you can instantly force an interrupt.
- A log window that continuously displays events for each defined interrupt.
- A status window that shows the current interrupt activities.

All interrupts you define using the **Interrupt Configuration** window are preserved between debug sessions, unless you remove them. A forced interrupt, on the other hand, exists only until it has been serviced and is not preserved between sessions.



The interrupt simulation system is activated by default, but if not required, you can turn off the interrupt simulation system to speed up the simulation. To turn it off, use either the **Interrupt Configuration** window or a system macro.

## INTERRUPT CHARACTERISTICS

The simulated interrupts consist of a set of characteristics which lets you fine-tune each interrupt to make it resemble the real interrupt on your target hardware. You can specify a *first activation time*, a *repeat interval*, a *hold time*, a *variance*, and a *probability*.

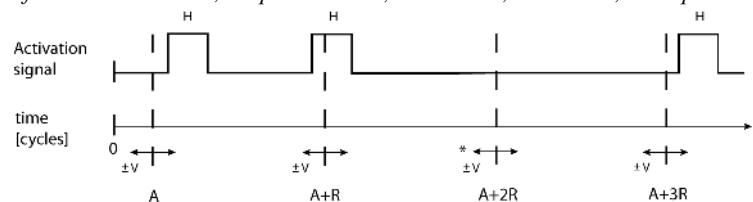

\* If probability is less than 100%, some interrupts may be omitted.

A = Activation time  
 R = Repeat interval  
 H = Hold time  
 V = Variance

The interrupt simulation system uses the cycle counter as a clock to determine when an interrupt should be raised in the simulator. You specify the *first activation time*, which is based on the cycle counter. C-SPY will generate an interrupt when the cycle counter has passed the specified activation time. However, interrupts can only be raised between

instructions, which means that a full assembler instruction must have been executed before the interrupt is generated, regardless of how many cycles an instruction takes.

To define the periodicity of the interrupt generation you can specify the *repeat interval* which defines the amount of cycles after which a new interrupt should be generated. In addition to the repeat interval, the periodicity depends on the two options *probability*—the probability, in percent, that the interrupt will actually appear in a period—and *variance*—a time variation range as a percentage of the repeat interval. These options make it possible to randomize the interrupt simulation. You can also specify a *hold time* which describes how long the interrupt remains pending until removed if it has not been processed. If the hold time is set to *infinite*, the corresponding pending bit will be set until the interrupt is acknowledged or removed.

## INTERRUPT SIMULATION STATES

The interrupt simulation system contains status information that you can use for locating timing problems in your application. The **Interrupt Status** window displays the available status information. For an interrupt, these states can be displayed: *Idle*, *Pending*, *Executing*, or *Suspended*.

Normally, a repeatable interrupt has a specified repeat interval that is longer than the execution time. In this case, the status information at different times looks like this:

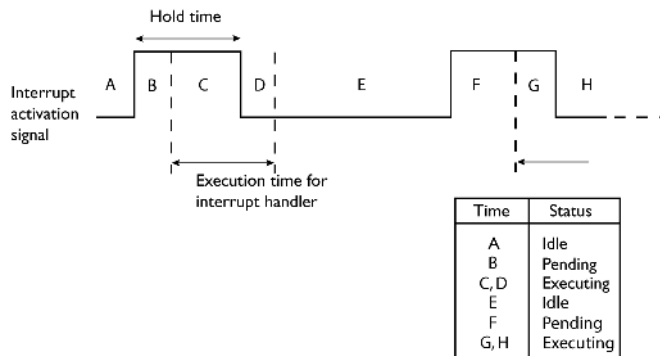

**Note:** The interrupt activation signal—also known as the pending bit—is automatically deactivated the moment the interrupt is acknowledged by the interrupt handler.

However, if the interrupt repeat interval is shorter than the execution time, and the interrupt is reentrant (or non-maskable), the status information at different times looks like this:

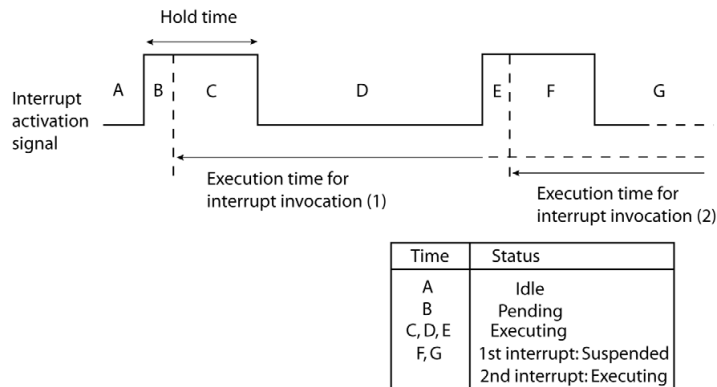

An execution time that is longer than the repeat interval might indicate that you should rewrite your interrupt handler and make it faster, or that you should specify a longer repeat interval for the interrupt simulation system.

## C-SPY SYSTEM MACROS FOR INTERRUPT SIMULATION

Macros are useful when you already have sorted out the details of the simulated interrupt so that it fully meets your requirements. If you write a macro function containing definitions for the simulated interrupts, you can execute the functions automatically when C-SPY starts. Another advantage is that your simulated interrupt definitions will be documented if you use macro files, and if you are several engineers involved in the development project you can share the macro files within the group.

When the IAR C-SPY simulator driver is used (see *Briefly about the interrupt simulation system*, page 401), the C-SPY Simulator provides these predefined system macros related to interrupts:

- `__cancelAllInterrupts`
- `__cancelInterrupt`
- `__disableInterrupts`
- `__enableInterrupts`
- `__orderInterrupt`
- `__popSimulatorInterruptExecutingStack`

The parameters of the first five macros correspond to the equivalent entries of the **Interrupt Configuration** window.



For more information about each macro, see *Reference information on C-SPY system macros*, page 444.

## TARGET-ADAPTING THE INTERRUPT SIMULATION SYSTEM

The interrupt simulation system is easy to use. However, to take full advantage of the interrupt simulation system you should be familiar with how to adapt it for the processor you are using.

The interrupt simulation has the same behavior as the hardware. This means that the execution of an interrupt is dependent on the status of the global interrupt enable bit. The execution of maskable interrupts is also dependent on the status of the individual interrupt enable bits.

To simulate device-specific interrupts, the interrupt system must have detailed information about each available interrupt. This information is provided in the device description files.

For information about device description files, see *Selecting a device description file*, page 57.

## BRIEFLY ABOUT INTERRUPT LOGGING

Interrupt logging provides you with comprehensive information about the interrupt events. This might be useful, for example, to help you locate which interrupts you can fine-tune to become faster. You can log entrances and exits to and from interrupts. If you are using the C-SPY simulator driver (see *Briefly about the interrupt simulation system*, page 401), you can also log internal interrupt status information, such as triggered, expired, etc. In the IDE:

- The logs are displayed in the **Interrupt Log** window
- A summary is available in the **Interrupt Log Summary** window
- The Interrupt graph in the **Timeline** window provides a graphical view of the interrupt events during the execution of your application

### Requirements for interrupt logging

Interrupt logging is supported by the C-SPY simulator driver (see *Briefly about the interrupt simulation system*, page 401). The Imperas Instruction Set Simulator does not support interrupt logging.

To use interrupt logging you need a Cortex-M device. You also need one of these alternatives:

- An I-jet or I-jet Trace in-circuit debugging probe, and an SWD interface between the debug probe and the target system

- A J-Link or J-Trace debug probe and an SWD interface between the debug probe and the target system
- An ST-LINK debug probe and an SWD interface between the debug probe and the target system
- A TI XDS debug probe and an SWD interface between the debug probe and the target system

See also *Getting started using interrupt logging*, page 409.

---

## Using the interrupt system

These tasks are covered:

- Simulating a simple interrupt
- Simulating an interrupt in a multi-task system
- Getting started using interrupt logging

See also:

- *Using C-SPY macros*, page 429 for details about how to use a setup file to define simulated interrupts at C-SPY startup
- The tutorial *Simulating an interrupt* in the Information Center.

### **SIMULATING A SIMPLE INTERRUPT**

This example demonstrates the method for simulating a timer interrupt. However, the procedure can also be used for other types of interrupts.

### To simulate and debug an interrupt:

- 1 Assume this simple application which contains an IRQ handler routine that handles system timer interrupts. It increments a tick variable. The main function sets the necessary status registers. The application exits when 100 interrupts have been generated.

```

/* Enables use of extended keywords */
#pragma language=extended

#include <intrinsics.h>
#include <stdio.h>

unsigned int ticks = 0;

/* IRQ handler */
#if __ARM_PROFILE_M__
/* Defines an interrupt handler for the Cortex-M UART interrupt.
*/
void UART_Handler()
#else
/* Defines an interrupt handler for other cores. */
__irq __arm void IRQ_Handler(void)
#endif
{
    /* We use only system timer interrupts, so we do not need
    to check the interrupt source. */
    ticks += 1;
    TMOVFR_bit.OVF = 1; /* Clear system timer overflow flag */
}

int main( void )
{
    __enable_interrupt();
    /* Timer setup code */
    ILC0_bit.ILR0 = 4; /* System timer interrupt priority */
    TMRLR_bit.TMRLR = 1E5; /* System timer reload value */
    TMEN_bit.TCEN = 1; /* Enable system timer */
    while (ticks < 100);
    printf("Done\n");
}

```

- 2 Add your interrupt service routine to your application source code and add the file to your project.
- 3 Build your project and start the simulator.

- 4 Choose **Simulator>Interrupt Configuration** to open the **Interrupt Configuration** window. Right-click in the window and select **Enable Interrupt Simulation** on the context menu. For the timer example, verify these settings:

Option	Settings
Interrupt	IRQ
First activation	4000
Repeat interval	2000
Hold time	10
Probability (%)	100
Variance (%)	0

Table 14: Timer interrupt settings

Click **OK**.

- 5 Execute your application. If you have enabled the interrupt properly in your application source code, C-SPY will:
  - Generate an interrupt when the cycle counter has passed 4000
  - Continuously repeat the interrupt after approximately 2000 cycles.
- 6 To watch the interrupt in action, choose **Simulator>Interrupt Log** to open the **Interrupt Log** window.
- 7 From the context menu, available in the **Interrupt Log** window, choose **Enable** to enable the logging. If you restart program execution, status information about entrances and exits to and from interrupts will now appear in the **Interrupt Log** window.

For information about how to get a graphical representation of the interrupts correlated with a time axis, see *Timeline window—Interrupt Log graph*, page 422.

## SIMULATING AN INTERRUPT IN A MULTI-TASK SYSTEM

If you are using interrupts in such a way that the normal instruction used for returning from an interrupt handler is not used, for example in an operating system with task-switching, the simulator cannot automatically detect that the interrupt has finished executing. The interrupt simulation system will work correctly, but the status information in the **Interrupt Configuration** window might not look as you expect. If too many interrupts are executing simultaneously, a warning might be issued.

### To simulate a normal interrupt exit:

- 1 Set a code breakpoint on the instruction that returns from the interrupt function.

- 2 Specify the `__popSimulatorInterruptExecutingStack` macro as a condition to the breakpoint.

When the breakpoint is triggered, the macro is executed and then the application continues to execute automatically.

## GETTING STARTED USING INTERRUPT LOGGING

- 1 To set up for interrupt logging, choose *C-SPY driver*>**SWO Configuration**. In the dialog box, set up the serial-wire output communication channel for trace data. Note specifically the **CPU clock** option. The CPU clock can also be set up on the **Project>Options>ST-LINK>Communication** page and the **Project>Options>TI XDS>Communication** page, respectively.

For the C-SPY simulator, no specific settings are required.

- 2 Choose *C-SPY driver*>**Interrupt Log** to open the **Interrupt Log** window. Optionally, you can also choose:
  - *C-SPY driver*>**Interrupt Log Summary** to open the **Interrupt Log Summary** window
  - *C-SPY driver*>**Timeline** to open the **Timeline** window and view the Interrupt graph
- 3 From the context menu in the **Interrupt Log** window, choose **Enable** to enable the logging.

In the **SWO Configuration** dialog box, you can see in the **Interrupt Log Events** area that interrupt logs are enabled.

- 4 Start executing your application program to collect the log information.
- 5 To view the interrupt log information, look in the **Interrupt Log** or **Interrupt Log Summary** window, or the Interrupt graph in the **Timeline** window.
- 6 If you want to save the log or summary to a file, choose **Save to log file** from the context menu in the window in question.
- 7 To disable interrupt logging, from the context menu in the **Interrupt Log** window, toggle **Enable** off.

---

## Reference information on interrupts

Reference information about:

- *Interrupt Configuration window*, page 410
- *Available Interrupts window*, page 413
- *Interrupt Status window*, page 414

- *Interrupt Log window*, page 416
- *Interrupt Log Summary window*, page 420
- *Timeline window—Interrupt Log graph*, page 422

## Interrupt Configuration window

The **Interrupt Configuration** window is available by choosing **Simulator>Interrupt Configuration**.

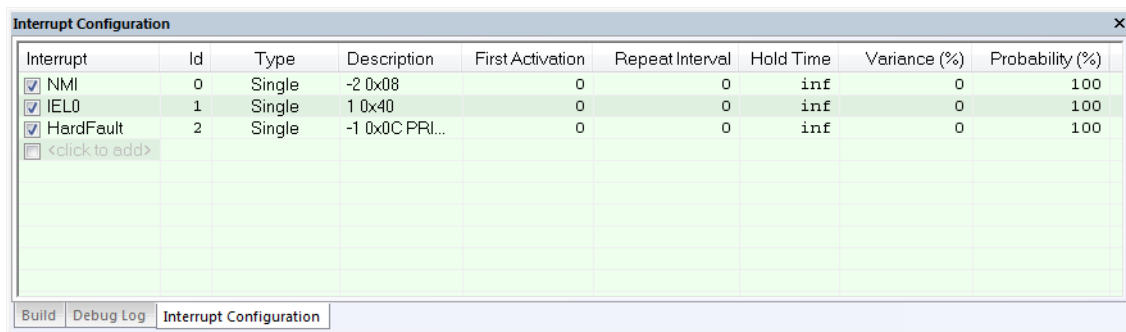

Interrupt	Id	Type	Description	First Activation	Repeat Interval	Hold Time	Variance (%)	Probability (%)
<input checked="" type="checkbox"/> NMI	0	Single	-2 0x08	0	0	inf	0	100
<input checked="" type="checkbox"/> IEL0	1	Single	1 0x40	0	0	inf	0	100
<input checked="" type="checkbox"/> HardFault	2	Single	-1 0x0C PRI...	0	0	inf	0	100
<input type="checkbox"/> <click to add>								

This window lists all installed interrupts. Use this window to enable or disable individual interrupts or the interrupt simulation system, and to edit the properties of installed interrupts.

See also *Using the interrupt system*, page 406.

### Requirements

The C-SPY simulator. Not available for all cores and devices.

### Display area

This area contains these columns:

#### Interrupt

Lists all installed interrupts. Use the checkbox to enable or disable the interrupt.

#### ID

A unique interrupt identifier.

#### Type

Shows the type of the interrupt. The type can be one of:

**Forced**, a single-occasion interrupt defined in the **Available Interrupts** window.

**Single**, a single-occasion interrupt.

**Repeat**, a periodically occurring interrupt.

If the interrupt has been set from a C-SPY macro, the additional part (**macro**) is added, for example: **Repeat(macro)**.

### Description

A description of the selected interrupt, if available. The description is retrieved from the selected device description file and consists of a string describing the priority, vector offset, enable bit, and pending bit, separated by space characters. The enable bit and pending bit are optional. It is possible to have none, only the enable bit, or both. For interrupts specified using the system macro `__orderInterrupt`, the **Description** box is empty.

For Cortex-M devices, the description is retrieved from the selected device description file and is editable. Enable bit and pending bit are not available from the ddf file—they must be manually edited if wanted. The priority is as in the hardware—the lower the number, the higher the priority. NMI and HardFault are special, and their descriptions should not be edited. Cortex-M interrupts are also affected by the `PRIMASK`, `FAULTMASK`, and `BASEPRI` registers, as described in the Arm documentation.

For other devices, the description strings for IRQ and FIQ are hardcoded and cannot be edited. In those descriptions, a higher priority number means a higher priority.

### First Activation

The value of the cycle counter after which the specified interrupt will be generated. Click to edit.

### Repeat Interval

The periodicity of the interrupt in cycles. Click to edit.

### Hold Time

How long, in cycles, the interrupt remains pending until removed if it has not been processed. Click to edit. If you specify `inf`, the corresponding pending bit will be set until the interrupt is acknowledged or removed.

### Variance %

A timing variation range, as a percentage of the repeat interval, in which the interrupt might occur for a period. For example, if the repeat interval is 100 and the variance 5%, the interrupt might occur anywhere between  $T=95$  and  $T=105$ , to simulate a variation in the timing. Click to edit.

**Probability %**

The probability, in percent, that the interrupt will actually occur within the specified period. Click to edit.

**Context menu**

This context menu is available:

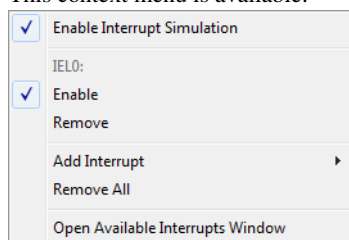

These commands are available:

**Enable Interrupt Simulation**

Enables or disables the entire interrupt simulation system. If the interrupt simulation is disabled, the definitions remain but no interrupts are generated. Note that you can also enable and disable installed interrupts individually by using the check box to the left of the interrupt name in the list of installed interrupts.

**Enable**

Enables or disables the individual interrupt you clicked on.

**Remove**

Removes the individual interrupt you clicked on.

**Add Interrupt**

Selects an interrupt to install. The drop-down list contains all available interrupts. Your selection will automatically update the **Description** box. The list is, for Cortex-M devices, populated with entries from the device description file that you have selected. For other devices, only two interrupts are available: IRQ and FIQ.

**Remove All**

Removes all installed interrupts in the window.

**Open Available Interrupts Window**

Opens the **Available Interrupts** window, see *Available Interrupts window*, page 413.



## Available Interrupts window

The **Available Interrupts** window is available from the C-SPY driver menu.

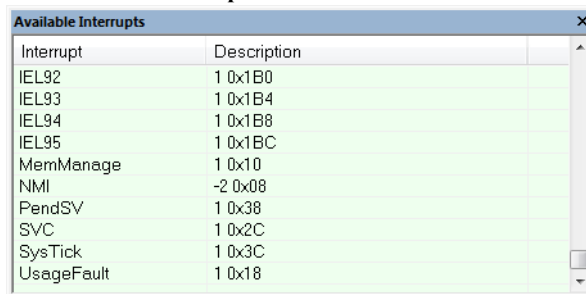

Interrupt	Description
IEL92	1 0x1B0
IEL93	1 0x1B4
IEL94	1 0x1B8
IEL95	1 0x1BC
MemManage	1 0x10
NMI	-2 0x08
PendSV	1 0x38
SVC	1 0x2C
SysTick	1 0x3C
UsageFault	1 0x18

Use this window for an overview of all available interrupts for your project. You can also use it for forcing an interrupt instantly. This is useful when you want to check your interrupt logic and interrupt routines. Just start typing an interrupt name and focus shifts to the first line found with that name.

The hold time for a forced interrupt is infinite, and the interrupt exists until it has been serviced or until a reset of the debug session.

To sort the window contents, click on either the **Interrupt** or the **Description** column header. A second click on the same column header reverses the sort order.

### To force an interrupt:

- 1 Enable the interrupt simulation system, see *Interrupt Configuration window*, page 410.
- 2 Activate the interrupt by choosing the **Force Interrupt** command from the context menu.

### Requirements

The C-SPY simulator. Not available for all cores and devices.

### Display area

This area lists all available interrupts and their definitions. This information is retrieved from the selected device description file. See this file for a detailed description.

## Context menu

This context menu is available:

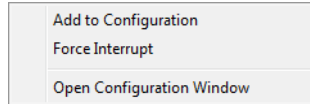

These commands are available:

### Add to Configuration

Installs the selected interrupt and adds it to the **Interrupt Configuration** window.

### Force Interrupt

Triggers the selected interrupt.

### Open Configuration Window

Opens the **Interrupt Configuration** window, see *Interrupt Configuration window*, page 410.

## Interrupt Status window

The **Interrupt Status** window is available from the C-SPY driver menu.

Interrupt	ID	Type	Status	Next Time	Timing [cycles]
TIM_INT	1	Single	Idle	0	0
NMI	0	Single	Idle	0	0
SCI0_I0	2	Repeat (macro)	Idle	4000	4000 + n*2000

This window shows the status of all the currently active interrupts, in other words interrupts that are either executing or waiting to be executed.

## Requirements

The C-SPY simulator. Not available for all cores and devices.

## Display area

This area contains these columns:

### Interrupt

Lists all interrupts.

**ID**

A unique interrupt identifier.

**Type**

The type of the interrupt. The type can be one of:

**Forced**, a single-occasion interrupt defined in the **Available Interrupts** window.

**Single**, a single-occasion interrupt.

**Repeat**, a periodically occurring interrupt.

If the interrupt has been set from a C-SPY macro, the additional part (**macro**) is added, for example: **Repeat(macro)**.

**Status**

The state of the interrupt:

**Idle**, the interrupt activation signal is low (deactivated).

**Pending**, the interrupt activation signal is active, but the interrupt has not been yet acknowledged by the interrupt handler.

**Executing**, the interrupt is currently being serviced, that is the interrupt handler function is executing.

**Suspended**, the interrupt is currently suspended due to execution of an interrupt with a higher priority.

**(deleted)** is added to **Executing** and **Suspended** if you have deleted a currently active interrupt. **(deleted)** is removed when the interrupt has finished executing.

**Next Time**

The next time an idle interrupt is triggered. Once a repeatable interrupt starts executing, a copy of the interrupt will appear with the state Idle and the next time set. For interrupts that do not have a next time—that is pending, executing, or suspended—the column will show --.

**Timing**

The timing of the interrupt. For a **Single** and **Forced** interrupt, the activation time is displayed. For a **Repeat** interrupt, the information has the form: *Activation Time + n\*Repeat Time*. For example, 2000 + n\*2345. This means that the first time this interrupt is triggered, is at 2000 cycles and after that with an interval of 2345 cycles.

## Interrupt Log window

The **Interrupt Log** window is available from the C-SPY driver menu.

Time	Interrupt	Status	Program Counter	Execution Time
109.32 us	IRQ0	Triggered	0x13E8	
111.26 us	IRQ0	Enter	0x13F0	
135.78 us	IRQ1	Enter	0x1126	
148.72 us	IRQ1	Leave	0x1378	12.94 us
<i>189.34 us</i>	<i>Overflow</i>			
207.30 us	IRQ0	Leave	0x1126	96.04 us
230.00 us	IRQ0	Triggered	0x1110	
231.34 us	IRQ0	Enter	0x1126	
240.26 us	IRQ0	Leave	0x1122	8.92 us
300.00 us	IRQ1	Enter	---	
371.12 us	IRQ1	Leave	0x1120	71.12 us
431.30 us	IRQ1	Enter	---	

Red indicates overflows and italic indicates approximate values

Light-colored rows indicate entrances to interrupts

Darker rows indicate exits from interrupts

This window logs entrances to and exits from interrupts. The C-SPY Simulator also logs internal state changes.

The information is useful for debugging the interrupt handling in the target system. When the **Interrupt Log** window is open, it is updated continuously at runtime.

**Note:** There is a limit on the number of saved logs. When this limit is exceeded, the oldest entries in the buffer are erased.

For more information, see *Getting started using interrupt logging*, page 409.

For information about how to get a graphical view of the interrupt events during the execution of your application, see *Timeline window—Interrupt Log graph*, page 422.

### Requirements

One of these alternatives:

- The C-SPY simulator. Not available for all cores and devices.
- An I-jet or I-jet Trace in-circuit debugging probe, and an SWD interface between the debug probe and the target system
- A J-Link or J-Trace debug probe with an SWD interface between the debug probe and the target system
- An ST-LINK debug probe with an SWD interface between the debug probe and the target system

- A TI XDS debug probe and an SWD interface between the debug probe and the target system

### Display area for the C-SPY hardware debugger drivers

This area contains these columns:

#### Time

The time for the interrupt entrance, based on the CPU clock frequency specified in the **SWO Configuration** dialog box.

If a time is displayed in italics, the target system has not been able to collect a correct time, but instead had to approximate it.

This column is available when you have selected **Show Time** from the context menu. If the **Show Time** command is not available, the **Time** column is displayed by default.

#### Cycles

The number of cycles from the start of the execution until the event.

A cycle count displayed in italics indicates an approximative value. Italics is used when the target system has not been able to collect a correct value, but instead had to approximate it.

This column is available when you have selected **Show Cycles** from the context menu provided that the C-SPY driver you are using supports it.

#### Interrupt

The name of the interrupt source where the interrupt occurred. If the column displays **Overflow** in red, the communication channel failed to transmit all interrupt logs from the target system.

#### Status

The event status of the interrupt:

**Enter**, the interrupt is currently executing.

**Leave**, the interrupt has finished executing.

#### Program Counter\*

The address of the interrupt handler.

#### Execution Time/Cycles

The time spent in the interrupt, calculated using the Enter and Leave timestamps. This includes time spent in any subroutines or other interrupts that occurred in the specific interrupt.

\* You can double-click an address. If it is available in the source code, the editor window displays the corresponding source code, for example for the interrupt handler (this does not include library source code).

### Display area for the C-SPY simulator

This area contains these columns:

#### Time

The time for the interrupt entrance, based on an internally specified clock frequency.

This column is available when you have selected **Show Time** from the context menu.

#### Cycles

The number of cycles from the start of the execution until the event.

This column is available when you have selected **Show Cycles** from the context menu.

#### Interrupt

The interrupt as defined in the device description file.

#### Status

Shows the event status of the interrupt:

**Triggered**, the interrupt has passed its activation time.

**Forced**, the same as Triggered, but the interrupt was forced from the **Available Interrupts** window.

**Enter**, the interrupt is currently executing.

**Leave**, the interrupt has been executed.

**Expired**, the interrupt hold time has expired without the interrupt being executed.

**Rejected**, the interrupt has been rejected because the necessary interrupt registers were not set up to accept the interrupt.

#### Program Counter

The value of the program counter when the event occurred.

#### Execution Time/Cycles

The time spent in the interrupt, calculated using the Enter and Leave timestamps. This includes time spent in any subroutines or other interrupts that occurred in the specific interrupt.

## Context menu

This context menu is available:

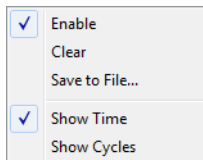

These commands are available:

### Enable

Enables the logging system. The system will log information also when the window is closed.

### Clear

Deletes the log information. Note that this will also happen when you reset the debugger.

### Save to File

Displays a standard file selection dialog box where you can select the destination file for the log information. The entries in the log file are separated by `TAB` and `LF` characters. An **X** in the **Approx** column indicates that the timestamp is an approximation.

### Show Time

Displays the **Time** column. If the **Time** column is displayed by default in the C-SPY driver you are using, this menu command is not available.

### Show Cycles

Displays the **Cycles** column. If the **Cycles** column is not supported in the C-SPY driver you are using, this menu command is not available.

## Interrupt Log Summary window

The **Interrupt Log Summary** window is available from the C-SPY driver menu.

Interrupt	Count	First Time	Total (Time)	Total (%)	Fastest	Slowest	Min Interval	Max Interval
ADC	5	25.560us	95.400us	17.61	16.320us	30.120us	192.640us	1284.100us
RTC	4	41.700us	55.200us	22.66	13.800us	13.800us	27.060us	2687.420us

Approximative time count: 1  
 Overflow count: 1  
 Current time: 3350.080us us

This window displays a summary of logs of entrances to and exits from interrupts.

For more information, see *Getting started using interrupt logging*, page 409.

For information about how to get a graphical view of the interrupt events during the execution of your application, see *Timeline window—Interrupt Log graph*, page 422.

### Requirements

One of these alternatives:

- The C-SPY simulator. Not available for all cores and devices.
- An I-jet or I-jet Trace in-circuit debugging probe, and an SWD interface between the debug probe and the target system
- A J-Link or J-Trace debug probe with an SWD interface between the debug probe and the target system
- An ST-LINK debug probe with an SWD interface between the debug probe and the target system
- A TI XDS debug probe and an SWD interface between the debug probe and the target system

### Display area for the C-SPY simulator

Each row in this area displays statistics about the specific interrupt based on the log information in these columns:

#### Interrupt

The type of interrupt that occurred.

At the bottom of the column, the current time or cycles is displayed—the number of cycles or the execution time since the start of execution. Overflow count and approximative time count is always zero.



**Count**

The number of times the interrupt occurred.

**First time**

The first time the interrupt was executed.

**Total (Time)\*\***

The accumulated time spent in the interrupt.

**Total (%)**

The time in percent of the current time.

**Fastest\*\***

The fastest execution of a single interrupt of this type.

**Slowest\*\***

The slowest execution of a single interrupt of this type.

**Min interval**

The shortest time between two interrupts of this type.

The interval is specified as the time interval between the entry time for two consecutive interrupts.

**Max interval**

The longest time between two interrupts of this type.

The interval is specified as the time interval between the entry time for two consecutive interrupts.

\*\* Calculated in the same way as for the Execution time/cycles in the **Interrupt Log** window.

**Context menu**

This context menu is available:

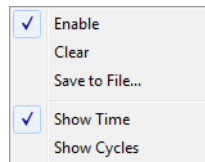

These commands are available:

**Enable**

Enables the logging system. The system will log information also when the window is closed.

**Clear**

Deletes the log information. Note that this will also happen when you reset the debugger.

**Save to File**

Displays a standard file selection dialog box where you can select the destination file for the log information. The entries in the log file are separated by TAB and LF characters. An X in the **Approx** column indicates that the timestamp is an approximation.

**Show Time**

Displays the **Time** column. If the **Time** column is displayed by default in the C-SPY driver you are using, this menu command is not available.

**Show Cycles**

Displays the **Cycles** column. If the **Cycles** column is not supported in the C-SPY driver you are using, this menu command is not available.

## Timeline window—Interrupt Log graph

The Interrupt Log graph displays interrupts collected by the trace system. In other words, the graph provides a graphical view of the interrupt events during the execution of your application.

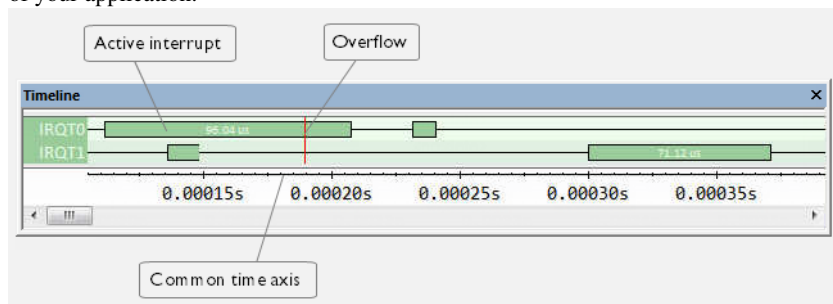

**Note:** There is a limit on the number of saved logs. When this limit is exceeded, the oldest entries in the buffer are erased.

**Display area**

- The label area at the left end of the graph displays the names of the interrupts.
- The graph itself shows active interrupts as a thick green horizontal bar where the white figure indicates the time spent in the interrupt. This graph is a graphical representation of the information in the **Interrupt Log** window, see *Interrupt Log window*, page 416.

- If the bar is displayed without horizontal borders, there are two possible causes:
  - The interrupt is reentrant and has interrupted itself. Only the innermost interrupt will have borders.
  - There are irregularities in the interrupt enter-leave sequence, probably due to missing logs.
- If the bar is displayed without a vertical border, the missing border indicates an approximate time for the log.
- A red vertical line indicates overflow, which means that the communication channel failed to transmit all interrupt logs from the target system.

At the bottom of the window, there is a common time axis that uses seconds as the time unit.

## Context menu

This context menu is available:

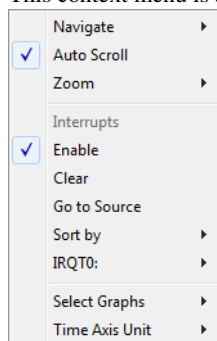

**Note:** The exact contents of the context menu you see on the screen depends on which features that your combination of software and hardware supports. However, the list of menu commands below is complete and covers all possible commands.

These commands are available:

### Navigate

Commands for navigating the graph(s). Choose between:

**Next** moves the selection to the next relevant point in the graph. Shortcut key: right arrow.

**Previous** moves the selection backward to the previous relevant point in the graph. Shortcut key: left arrow.

**First** moves the selection to the first data entry in the graph. Shortcut key: Home.

**Last** moves the selection to the last data entry in the graph. Shortcut key: End.

**End** moves the selection to the last data in any displayed graph, in other words the end of the time axis. Shortcut key: Ctrl+End.

### **Auto Scroll**

Toggles automatic scrolling on or off. When on, the most recently collected data is automatically displayed when you choose **Navigate>End**.

### **Zoom**

Commands for zooming the window, in other words, changing the time scale. Choose between:

**Zoom to Selection** makes the current selection fit the window. Shortcut key: Return.

**Zoom In** zooms in on the time scale. Shortcut key: +

**Zoom Out** zooms out on the time scale. Shortcut key: –

**10ns, 100ns, 1us**, etc makes an interval of 10 nanoseconds, 100 nanoseconds, 1 microsecond, respectively, fit the window.

**1ms, 10ms**, etc makes an interval of 1 millisecond or 10 milliseconds, respectively, fit the window.

**10m, 1h**, etc makes an interval of 10 minutes or 1 hour, respectively, fit the window.

### **Interrupts**

A heading that shows that the Interrupt Log-specific commands below are available.

#### **Enable**

Toggles the display of the graph on or off. If you disable a graph, that graph will be indicated as **OFF** in the window. If no data has been collected for a graph, **no data** will appear instead of the graph.

#### **Clear**

Deletes the log information. Note that this will also happen when you reset the debugger.

#### **Go To Source**

Displays the corresponding source code in an editor window, if applicable.

#### **Sort by**

Sorts the entries according to their ID or name. The selected order is used in the graph when new interrupts appear.

***source***

Goes to the previous/next log for the selected source.

**Select Graphs**

Selects which graphs to be displayed in the **Timeline** window.

**Time Axis Unit**

Selects the unit used in the time axis—choose between **Seconds** and **Cycles**.

If **Cycles** is not available, the graphs are based on different clock sources. In that case you can view cycle values as tooltip information by pointing at the graph with your mouse pointer.



# C-SPY macros

- Introduction to C-SPY macros
- Using C-SPY macros
- Reference information on the macro language
- Reference information on reserved setup macro function names
- Reference information on C-SPY system macros
- Graphical environment for macros

---

## Introduction to C-SPY macros

These topics are covered:

- Reasons for using C-SPY macros
- Briefly about using C-SPY macros
- Briefly about setup macro functions and files
- Briefly about the macro language

### REASONS FOR USING C-SPY MACROS

You can use C-SPY macros either by themselves or in conjunction with complex breakpoints and interrupt simulation to perform a wide variety of tasks. Some examples where macros can be useful:

- Automating the debug session, for instance with trace printouts, printing values of variables, and setting breakpoints.
- Hardware configuring, such as initializing hardware registers.
- Feeding your application with simulated data during runtime.
- Simulating peripheral devices, see the chapter *Interrupts*. This only applies if you are using the simulator driver.
- Developing small debug utility functions, for instance calculating the stack depth, see the provided example `stack.mac` located in the directory `\arm\src\`.

## BRIEFLY ABOUT USING C-SPY MACROS

To use C-SPY macros, you should:

- Write your macro variables and functions and collect them in one or several *macro files*
- Register your macros
- Execute your macros

For registering and executing macros, there are several methods to choose between. Which method you choose depends on which level of interaction or automation you want, and depending on at which stage you want to register or execute your macro.

## BRIEFLY ABOUT SETUP MACRO FUNCTIONS AND FILES

There are some reserved *setup macro function names* that you can use for defining macro functions which will be called at specific times, such as:

- Once after communication with the target system has been established but before downloading the application software
- Once after your application software has been downloaded
- Each time the reset command is issued
- Once when the debug session ends

To define a macro function to be called at a specific stage, you should define and register a macro function with one of the reserved names. For instance, if you want to clear a specific memory area before you load your application software, the macro setup function `execUserPreload` should be used. This function is also suitable if you want to initialize some CPU registers or memory-mapped peripheral units before you load your application software.

You should define these functions in a *setup macro file*, which you can load before C-SPY starts. Your macro functions will then be automatically registered each time you start C-SPY. This is convenient if you want to automate the initialization of C-SPY, or if you want to register multiple setup macros.

For more information about each setup macro function, see *Reference information on reserved setup macro function names*, page 439.

## Remapping memory

A common feature of many Arm-based processors is the ability to remap memory. After a reset, the memory controller typically maps address zero to non-volatile memory, such as flash. By configuring the memory controller, the system memory can be remapped to place RAM at zero and non-volatile memory higher up in the address map. By doing this, the exception table will reside in RAM and can be easily modified when you



download code to the target hardware. To handle this in C-SPY, the setup macro function `execUserPreload()` is suitable. For an example, see *Remapping memory*, page 63.

## BRIEFLY ABOUT THE MACRO LANGUAGE

The syntax of the macro language is very similar to the C language. There are:

- *Macro statements*, which are similar to C statements.
- *Macro functions*, which you can define with or without parameters and return values.
- Predefined built-in *system macros*, similar to C library functions, which perform useful tasks such as opening and closing files, setting breakpoints, and defining simulated interrupts.
- *Macro variables*, which can be global or local, and can be used in C-SPY expressions.
- *Macro strings*, which you can manipulate using predefined system macros.

For more information about the macro language components, see *Reference information on the macro language*, page 434.

### Example

Consider this example of a macro function which illustrates the various components of the macro language:

```
__var oldVal;
CheckLatest(val)
{
    if (oldVal != val)
    {
        __message "Message: Changed from ", oldVal, " to ", val, "\n";
        oldVal = val;
    }
}
```

**Note:** Reserved macro words begin with double underscores to prevent name conflicts.

---

## Using C-SPY macros

These tasks are covered:

- Registering C-SPY macros—an overview
- Executing C-SPY macros—an overview
- Registering and executing using setup macros and setup files

- Executing macros using Quick Watch
- Executing a macro by connecting it to a breakpoint
- Aborting a C-SPY macro

For more examples using C-SPY macros, see:

- The tutorial about simulating an interrupt, which you can find in the Information Center
- *Initializing target hardware before C-SPY starts*, page 62

## REGISTERING C-SPY MACROS—AN OVERVIEW

C-SPY must know that you intend to use your defined macro functions, and therefore you must *register* your macros. There are various ways to register macro functions:

- You can register macro functions during the C-SPY startup sequence, see *Registering and executing using setup macros and setup files*, page 431.
- You can register macros interactively in the **Macro Registration** window, see *Macro Registration window*, page 509. Registered macros appear in the **Debugger Macros** window, see *Debugger Macros window*, page 511.
- You can register a file containing macro function definitions, using the system macro `__registerMacroFile`. This means that you can dynamically select which macro files to register, depending on the runtime conditions. Using the system macro also lets you register multiple files at the same moment. For information about the system macro, see *\_\_registerMacroFile*, page 484.

Which method you choose depends on which level of interaction or automation you want, and depending on at which stage you want to register your macro.

## EXECUTING C-SPY MACROS—AN OVERVIEW

There are various ways to execute macro functions:

- You can execute macro functions during the C-SPY startup sequence and at other predefined stages during the debug session by defining setup macro functions in a setup macro file, see *Registering and executing using setup macros and setup files*, page 431.
- The **Quick Watch** window lets you evaluate expressions, and can thus be used for executing macro functions. For an example, see *Executing macros using Quick Watch*, page 432.
- The **Macro Quicklaunch** window is similar to the **Quick Watch** window, but is more specifically designed for C-SPY macros. See *Macro Quicklaunch window*, page 513.

- A macro can be connected to a breakpoint; when the breakpoint is triggered the macro is executed. For an example, see *Executing a macro by connecting it to a breakpoint*, page 432.

Which method you choose depends on which level of interaction or automation you want, and depending on at which stage you want to execute your macro.

## REGISTERING AND EXECUTING USING SETUP MACROS AND SETUP FILES

It can be convenient to register a macro file during the C-SPY startup sequence. To do this, specify a macro file which you load before starting the debug session. Your macro functions will be automatically registered each time you start the debugger.

If you use the reserved setup macro function names to define the macro functions, you can define exactly at which stage you want the macro function to be executed.

### To define a setup macro function and load it during C-SPY startup:

- 1 Create a new text file where you can define your macro function.

For example:

```
execUserSetup()
{
    ...
    __registerMacroFile("MyMacroUtils.mac");
    __registerMacroFile("MyDeviceSimulation.mac");
}
```

This macro function registers the additional macro files `MyMacroUtils.mac` and `MyDeviceSimulation.mac`. Because the macro function is defined with the function name `execUserSetup`, it will be executed directly after your application has been downloaded.

- 2 Save the file using the filename extension `mac`.
- 3 Before you start C-SPY, choose **Project>Options>Debugger>Setup**. Select the **Use macro file** option, and choose the macro file you just created.

The macros will now be registered during the C-SPY startup sequence.

## EXECUTING MACROS USING QUICK WATCH

The **Quick Watch** window lets you dynamically choose when to execute a macro function.

- 1 Consider this simple macro function that checks the status of a timer enable bit:

```
TimerStatus()
{
    if ((TimerStatreg & 0x01) != 0) /* Checks the status of reg */
        return "Timer enabled"; /* C-SPY macro string used */
    else
        return "Timer disabled"; /* C-SPY macro string used */
}
```

- 2 Save the macro function using the filename extension `mac`.
- 3 To load the macro file, choose **View>Macros>Macro Registration**. The **Macro Registration** window is displayed. Click **Add** and locate the file using the file browser. The macro file appears in the list of macros in the **Macro Registration** window.
- 4 Select the macro you want to register and your macro will appear in the **Debugger Macros** window.
- 5 Choose **View>Quick Watch** to open the **Quick Watch** window, type the macro call `TimerStatus()` in the text field and press Return,

Alternatively, in the macro file editor window, select the macro function name `TimerStatus()`. Right-click, and choose **Quick Watch** from the context menu that appears.

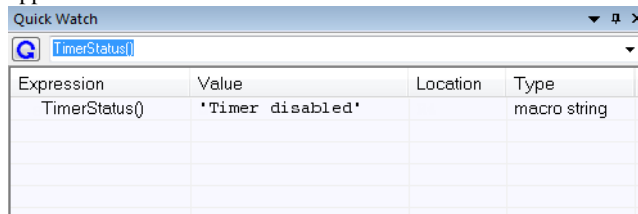

Expression	Value	Location	Type
TimerStatus()	'Timer disabled'		macro string

The macro will automatically be displayed in the **Quick Watch** window. For more information, see *Quick Watch window*, page 118.

## EXECUTING A MACRO BY CONNECTING IT TO A BREAKPOINT

You can connect a macro to a breakpoint. The macro will then be executed when the breakpoint is triggered. The advantage is that you can stop the execution at locations of particular interest and perform specific actions there.



For instance, you can easily produce log reports containing information such as how the values of variables, symbols, or registers change. To do this you might set a breakpoint on a suspicious location and connect a log macro to the breakpoint. After the execution you can study how the values of the registers have changed.

### To create a log macro and connect it to a breakpoint:

- 1 Assume this skeleton of a C function in your application source code:

```
int fact(int x)
{
    ...
}
```

- 2 Create a simple log macro function like this example:

```
logfact()
{
    __message "fact(" ,x, ")";
}
```

The `__message` statement will log messages to the **Debug Log** window.

Save the macro function in a macro file, with the filename extension `mac`.

- 3 To register the macro, choose **View>Macros>Macro Registration** to open the **Macro Registration** window and add your macro file to the list. Select the file to register it. Your macro function will appear in the **Debugger Macros** window.
  - 4 To set a code breakpoint, click the **Toggle Breakpoint** button on the first statement within the function `fact` in your application source code. Choose **View>Breakpoints** to open the **Breakpoints** window. Select your breakpoint in the list of breakpoints and choose the **Edit** command from the context menu.
  - 5 To connect the log macro function to the breakpoint, type the name of the macro function, `logfact()`, in the **Action** field and click **OK** to close the dialog box.
  - 6 Execute your application source code. When the breakpoint is triggered, the macro function will be executed. You can see the result in the **Debug Log** window.
- Note that the expression in the **Action** field is evaluated only when the breakpoint causes the execution to really stop. If you want to log a value and then automatically continue execution, you can either:
- Use a **Log** breakpoint, see *Log breakpoints dialog box*, page 146
  - Use the **Condition** field instead of the **Action** field. For an example, see *Performing a task and continuing execution*, page 137.

- 7 You can easily enhance the log macro function by, for instance, using the `__fmessage` statement instead, which will print the log information to a file. For information about the `__fmessage` statement, see *Formatted output*, page 438.

For an example where a serial port input buffer is simulated using the method of connecting a macro to a breakpoint, see the tutorial *Simulating an interrupt* in the Information Center.

## ABORTING A C-SPY MACRO

### To abort a C-SPY macro:

- 1 Press Ctrl+Shift+. (period) for a short while.
- 2 A message that says that the macro has terminated is displayed in the **Debug Log** window.

This method can be used if you suspect that something is wrong with the execution, for example because it seems not to terminate in a reasonable time.

---

## Reference information on the macro language

Reference information about:

- *Macro functions*, page 434
- *Macro variables*, page 435
- *Macro parameters*, page 435
- *Macro strings*, page 436
- *Macro statements*, page 436
- *Formatted output*, page 438

## MACRO FUNCTIONS

C-SPY macro functions consist of C-SPY variable definitions and macro statements which are executed when the macro is called. An unlimited number of parameters can be passed to a macro function, and macro functions can return a value on exit.

A C-SPY macro has this form:

```
macroName (parameterList)
{
    macroBody
}
```

where *parameterList* is a list of macro parameters separated by commas, and *macroBody* is any series of C-SPY variable definitions and C-SPY statements.

Type checking is neither performed on the values passed to the macro functions nor on the return value.

## MACRO VARIABLES

A macro variable is a variable defined and allocated outside your application. It can then be used in a C-SPY expression, or you can assign application data—values of the variables in your application—to it. For more information about C-SPY expressions, see *C-SPY expressions*, page 98.

The syntax for defining one or more macro variables is:

```
__var nameList;
```

where *nameList* is a list of C-SPY variable names separated by commas.

A macro variable defined outside a macro body has global scope, and it exists throughout the whole debugging session. A macro variable defined within a macro body is created when its definition is executed and destroyed on return from the macro.

By default, macro variables are treated as signed integers and initialized to 0. When a C-SPY variable is assigned a value in an expression, it also acquires the type of that expression. For example:

Expression	What it means
<code>myvar = 3.5;</code>	<code>myvar</code> is now type <code>double</code> , value <code>3.5</code> .
<code>myvar = (int*)i;</code>	<code>myvar</code> is now type <code>pointer to int</code> , and the value is the same as <code>i</code> .

Table 15: Examples of C-SPY macro variables

In case of a name conflict between a C symbol and a C-SPY macro variable, C-SPY macro variables have a higher precedence than C variables. Note that macro variables are allocated on the debugger host and do not affect your application.

## MACRO PARAMETERS

A macro parameter is intended for parameterization of device support. The named parameter will behave as a normal C-SPY macro variable with these differences:

- The parameter definition can have an initializer
- Values of a parameters can be set through options (either in the IDE or in `cspybat`).
- A value set from an option will take precedence over a value set by an initializer
- A parameter must have an initializer, be set through an option, or both. Otherwise, it has an undefined value, and accessing it will cause a runtime error.

The syntax for defining one or more macro parameters is:

```
__param param[=value, ...;]
```

Use the command line option `--macro_param` to specify a value to a parameter, see `--macro_param`, page 562.

## MACRO STRINGS

In addition to C types, macro variables can hold values of *macro strings*. Note that macro strings differ from C language strings.

When you write a string literal, such as `"Hello!"`, in a C-SPY expression, the value is a macro string. It is not a C-style character pointer `char*`, because `char*` must point to a sequence of characters in target memory and C-SPY cannot expect any string literal to actually exist in target memory.

You can manipulate a macro string using a few built-in macro functions, for example `__strFind` or `__subString`. The result can be a new macro string. You can concatenate macro strings using the `+` operator, for example `str + "tail"`. You can also access individual characters using subscription, for example `str[3]`. You can get the length of a string using `sizeof(str)`. Note that a macro string is not NULL-terminated.

The macro function `__toString` is used for converting from a NULL-terminated C string in your application (`char*` or `char[]`) to a macro string. For example, assume this definition of a C string in your application:

```
char const *cstr = "Hello";
```

Then examine these macro examples:

```
__var str;          /* A macro variable */
str = cstr          /* str is now just a pointer to char */
sizeof str         /* same as sizeof (char*), typically 2 or 4 */
str = __toString(cstr,512) /* str is now a macro string */
sizeof str        /* 5, the length of the string */
str[1]            /* 101, the ASCII code for 'e' */
str += " World!" /* str is now "Hello World!" */
```

See also *Formatted output*, page 438.

## MACRO STATEMENTS

Statements are expected to behave in the same way as the corresponding C statements would do. The following C-SPY macro statements are accepted:

### Expressions

```
expression;
```



For more information about C-SPY expressions, see *C-SPY expressions*, page 98.

**Note:** On 64-bit architectures, the expression `#PC` becomes ambiguous in C-SPY macros. Therefore, when you debug a 64-bit MCU, you must use `#PC32` for AArch32 and `#PC64` for AArch64 in C-SPY macros. When debugging a 32-bit MCU, use `#PC`.

### Conditional statements

```
if (expression)
    statement
```

```
if (expression)
    statement
else
    statement
```

### Loop statements

```
for (init_expression; cond_expression; update_expression)
    statement
```

```
while (expression)
    statement
```

```
do
    statement
while (expression);
```

### Return statements

```
return;
```

```
return expression;
```

If the return value is not explicitly set, signed int 0 is returned by default.

### Blocks

Statements can be grouped in blocks.

```
{
    statement1
    statement2
    .
    .
    statementN
}
```

## FORMATTED OUTPUT

C-SPY provides various methods for producing formatted output:

<code>__message argList;</code>	Prints the output to the <b>Debug Log</b> window.
<code>__fmessage file, argList;</code>	Prints the output to the designated file.
<code>__smessage argList;</code>	Returns a string containing the formatted output.

where *argList* is a comma-separated list of C-SPY expressions or strings, and *file* is the result of the `__openFile` system macro, see `__openFile`, page 476.

To produce messages in the **Debug Log** window:

```
var1 = 42;
var2 = 37;
__message "This line prints the values ", var1, " and ", var2,
" in the Debug Log window.";
```

This produces this message in the **Debug Log** window:

This line prints the values 42 and 37 in the Debug Log window.

To write the output to a designated file:

```
__fmessage myfile, "Result is ", res, "!\n";
```

To produce strings:

```
myMacroVar = __smessage 42, " is the answer.";
myMacroVar now contains the string "42 is the answer.".
```

## Specifying display format of arguments

To override the default display format of a scalar argument (number or pointer) in *argList*, suffix it with a `:` followed by a format specifier. Available specifiers are:

<code>%b</code>	for binary scalar arguments
<code>%o</code>	for octal scalar arguments
<code>%d</code>	for decimal scalar arguments
<code>%x</code>	for hexadecimal scalar arguments
<code>%c</code>	for character scalar arguments

These match the formats available in the **Watch** and **Locals** windows, but number prefixes and quotes around strings and characters are not printed.

Example:

```
__message "The character '", cvar:%c, "' has the decimal value
", cvar;
```

Depending on the value of the variables, this produces this message:

```
The character 'A' has the decimal value 65
```

**Note:** A character enclosed in single quotes (a character literal) is an integer constant and is not automatically formatted as a character. For example:

```
__message 'A', " is the numeric value of the character ",
'A':%c;
```

would produce:

```
65 is the numeric value of the character A
```

Optionally, a number can be inserted between the % and the letter, to format an integer to that minimum width. Binary, octal, and hexadecimal numbers will be left-padded with zeros, decimal numbers and characters will be padded with spaces. Note that numbers that do not fit within the requested minimum width will *not* be truncated.

Examples:

```
__message 31:%4x;      // 001f
__message 31:%4d;      // 31
__message 31:%8b;      // 00011111
```

**Note:** The default format for certain types is primarily designed to be useful in the **Watch** window and other related windows. For example, a value of type `char` is formatted as `'A' (0x41)`, while a pointer to a character (potentially a C string) is formatted as `0x8102 "Hello"`, where the string part shows the beginning of the string (currently up to 60 characters).

When printing a value of type `char*`, use the `%x` format specifier to print just the pointer value in hexadecimal notation, or use the system macro `__toString` to get the full string value.

---

## Reference information on reserved setup macro function names

There are reserved setup macro function names that you can use for defining your setup macro functions. By using these reserved names, your function will be executed at defined stages during execution. For more information, see *Briefly about setup macro functions and files*, page 428.

Reference information about:

- `execConfigureTraceETM`

- `execConfigureTraceSWO`
- `execUserAttach`
- `execUserPreload`
- `execUserExecutionStarted`
- `execUserExecutionStopped`
- `execUserFlashInit`
- `execUserSetup`
- `execUserFlashReset`
- `execUserPreReset`
- `execUserReset`
- `execUserExit`
- `execUserFlashExit`
- `execUserCoreConnect`

## **execConfigureTraceETM**

Syntax	<code>execConfigureTraceETM</code>
For use with	All C-SPY hardware drivers where full instruction trace is supported and enabled.
Description	This macro is executed just before execution begins, and should be used for setting up device-specific registers that might be required to get full instruction trace (ETM/PTM) out to a physical pin, or to configure device-specific parts of an on-chip trace unit (ETB/MTB/PTB).

## **execConfigureTraceSWO**

Syntax	<code>execConfigureTraceSWO</code>
For use with	All C-SPY hardware drivers where SWO trace is supported and enabled.
Description	This macro is executed just before execution begins, and should be used for setting up device-specific registers that might be required to get SWO trace out to a physical pin.  Configuring SWO/ITM or TPIU should generally not be required here, because this is handled by the probe driver.

## execUserAttach

Syntax	<code>execUserAttach</code>
For use with	All C-SPY hardware debugger drivers except CADI.
Description	<p>Called after the debugger attaches to a running application at its current location without resetting the target system (the option <b>Attach to running target</b>).</p> <p>Implement this macro to set up the memory map, breakpoints, interrupts, register macro files, etc.</p>

## execUserPreload

Syntax	<code>execUserPreload</code>
For use with	All C-SPY drivers.
Description	<p>Called after communication with the target system is established but before downloading the target application.</p> <p>Implement this macro to initialize memory locations and/or registers which are vital for loading data properly.</p> <p><b>Note:</b> Do not use this macro if you are using a flash loader. Use the macro <code>execUserFlashInit</code> instead to perform early initializations required by the flash loader, see <i>execUserFlashInit</i>, page 442.</p>

## execUserExecutionStarted

Syntax	<code>execUserExecutionStarted</code>
For use with	All C-SPY drivers.
Description	<p>Called when the debugger is about to start or resume execution. The macro is not called when performing a one-instruction assembler step, in other words, <b>Step</b> or <b>Step Into</b> in the <b>Disassembly</b> window.</p>

## execUserExecutionStopped

Syntax	<code>execUserExecutionStopped</code>
--------	---------------------------------------

For use with	All C-SPY drivers.
Description	Called when the debugger has stopped execution. The macro is not called when performing a one-instruction assembler step, in other words, <b>Step</b> or <b>Step Into</b> in the <b>Disassembly</b> window.

## execUserFlashInit

Syntax	<code>execUserFlashInit</code>
For use with	The C-SPY hardware debugger drivers.
Description	Called once before the flash loader is downloaded to RAM. Implement this macro typically for setting up the memory map required by the flash loader. This macro is only called when you are programming flash, and it should only be used for flash loader functionality.

## execUserSetup

Syntax	<code>execUserSetup</code>
For use with	All C-SPY drivers.
Description	<p>Called once after the target application is downloaded.</p> <p>Implement this macro to set up the memory map, breakpoints, interrupts, register macro files, etc.</p> <p> If you define interrupts or breakpoints in a macro file that is executed at system start (using <code>execUserSetup</code>) we strongly recommend that you also make sure that they are removed at system shutdown (using <code>execUserExit</code>). An example is available in <code>SetupSimple.mac</code>, see the tutorials in the Information Center.</p> <p>The reason for this is that the simulator saves interrupt settings between sessions and if they are not removed they will get duplicated every time <code>execUserSetup</code> is executed again. This seriously affects the execution speed.</p>

## execUserFlashReset

Syntax	<code>execUserFlashReset</code>
For use with	The C-SPY hardware debugger drivers.

Description	Called once after the flash loader is downloaded to RAM, but before execution of the flash loader. This macro is only called when you are programming flash, and it should only be used for flash loader functionality.
-------------	---

### **execUserPreReset**

Syntax	<code>execUserPreReset</code>
For use with	All C-SPY drivers.
Description	Called each time just before the reset command is issued. Implement this macro to set up any required device state.

### **execUserReset**

Syntax	<code>execUserReset</code>
For use with	All C-SPY drivers.
Description	Called each time just after the reset command is issued. Implement this macro to set up and restore data.

### **execUserExit**

Syntax	<code>execUserExit</code>
For use with	All C-SPY drivers.
Description	Called once when the debug session ends. Implement this macro to save status data etc.

### **execUserFlashExit**

Syntax	<code>execUserFlashExit</code>
For use with	The C-SPY hardware debugger drivers.
Description	Called once when the flash programming ends.

Implement this macro to save status data etc. This macro is useful for flash loader functionality.

## execUserCoreConnect

Syntax	execUserCoreConnect
For use with	The C-SPY CMSIS-DAP driver. The C-SPY I-jet driver. The C-SPY ST-LINK driver. The C-SPY TI MSP-FET driver. The C-SPY TI Stellaris driver. The C-SPY TI XDS driver.
Description	Called immediately when connection with the probe is established.  Implement this macro to perform actions before connecting the CPU. This macro is useful for unlocking/erasing a secured device.

---

## Reference information on C-SPY system macros

This section gives reference information about each of the C-SPY system macros.

This table summarizes the pre-defined system macros:

Macro	Description
__argCount	Returns the number of arguments in a string. See the documentation in the <i>Flash Loader Development Guide</i> .
__abortLaunch	Aborts the launch of the debugger
__bytes2Word16	Extracts a 16-bit word from a buffer. See the documentation in the <i>Flash Loader Development Guide</i> .
__bytes2Word32	Extracts a 32-bit word from a buffer. See the documentation in the <i>Flash Loader Development Guide</i> .
__cancelAllInterrupts	Cancels all ordered interrupts
__cancelInterrupt	Cancels an interrupt
__clearBreak	Clears a breakpoint
__closeFile	Closes a file that was opened by <code>__openFile</code>

Table 16: Summary of system macros



Macro	Description
<code>__delay</code>	Delays execution
<code>__disableInterrupts</code>	Disables generation of interrupts
<code>__driverType</code>	Verifies the driver type
<code>__emulatorSpeed</code>	Sets the emulator clock frequency
<code>__emulatorStatusCheckOnRead</code>	Enables or disables the verification of the CPSR register after each read operation
<code>__enableInterrupts</code>	Enables generation of interrupts
<code>__evaluate</code>	Interprets the input string as an expression and evaluates it
<code>__expandVar</code>	Expands all argument variables in a string
<code>__fillMemory8</code>	Fills a specified memory area with a byte value
<code>__fillMemory16</code>	Fills a specified memory area with a 2-byte value
<code>__fillMemory32</code>	Fills a specified memory area with a 4-byte value
<code>__fillMemory64</code>	Fills a specified memory area with an 8-byte value
<code>__gdbserver_exec_command</code>	Send strings or commands to the GDB Server
<code>__getArg</code>	Returns an argument from a string. See the documentation in the <i>Flash Loader Development Guide</i> .
<code>__getNumberOfCores</code>	Gets the number local cores being debugged.
<code>__getSelectedCore</code>	Gets the number of the current core.
<code>__getTracePortSize</code>	Returns the width of the trace port
<code>__hasDAPRegs</code>	Returns true if the C-SPY driver supports the macros <code>__readAPReg</code> , <code>__readDPReg</code> , and <code>__writeAPReg</code> , and <code>__writeDPReg</code>
<code>__hwJetResetWithStrategy</code>	Performs a hardware reset and a halt of the target CPU
<code>__hwReset</code>	Performs a hardware reset and a halt of the target CPU
<code>__hwResetRunToBp</code>	Performs a hardware reset and then executes to the specified address
<code>__hwResetWithStrategy</code>	Performs a hardware reset and halt with delay of the target CPU
<code>__hwRunToBreakpoint</code>	Sets a temporary breakpoint and starts the execution
<code>__isBatchMode</code>	Checks if C-SPY is running in batch mode or not.
<code>__isMacroSymbolDefined</code>	Checks if a C-SPY macro symbol is defined.

Table 16: Summary of system macros (Continued)

Macro	Description
<code>__jlinkExecCommand</code>	Sends a low-level command to the J-Link/J-Trace driver
<code>__jlinkExecMacro</code>	Calls a function (without any parameter) in a J-Link script file.
<code>__jtagCommand</code>	Sends a low-level command to the JTAG instruction register
<code>__jtagCP15IsPresent</code>	Checks if coprocessor CP15 is available
<code>__jtagCP15ReadReg</code>	Returns the coprocessor CP15 register value
<code>__jtagCP15WriteReg</code>	Writes to the coprocessor CP15 register
<code>__jtagData</code>	Sends a low-level data value to the JTAG data register
<code>__jtagRawRead</code>	Returns the read data from the JTAG interface
<code>__jtagRawSync</code>	Writes accumulated data to the JTAG interface
<code>__jtagRawWrite</code>	Accumulates data to be transferred to the JTAG
<code>__jtagResetTRST</code>	Resets the ARM TAP controller via the TRST JTAG signal
<code>__loadImage</code>	Loads a debug image
<code>__makeString</code>	Creates a new buffer string. See the documentation in the <i>Flash Loader Development Guide</i> .
<code>__memoryRestore</code>	Restores the contents of a file to a specified memory zone
<code>__memorySave</code>	Saves the contents of a specified memory area to a file
<code>__messageBoxYesCancel</code>	Displays a Yes/Cancel dialog box for user interaction
<code>__messageBoxYesNo</code>	Displays a Yes/No dialog box for user interaction
<code>__openFile</code>	Opens a file for I/O operations
<code>__orderInterrupt</code>	Generates an interrupt
<code>__popSimulatorInterruptExecutingStack</code>	Informs the interrupt simulation system that an interrupt handler has finished executing
<code>__probeType</code>	Verifies the probe type
<code>__readAPReg</code>	Reads from an AP register
<code>__readDPReg</code>	Reads from a DP register
<code>__readFile</code>	Reads from the specified file
<code>__readFileByte</code>	Reads one byte from the specified file

Table 16: Summary of system macros (Continued)

Macro	Description
<code>__readMemory8,</code> <code>__readMemoryByte</code>	Reads one byte from the specified memory location
<code>__readMemory16</code>	Reads two bytes from the specified memory location
<code>__readMemory32</code>	Reads four bytes from the specified memory location
<code>__readMemory64</code>	Reads eight bytes from the specified memory location
<code>__readMemoryBuffer</code>	Reads bytes and returns them as a string. See the documentation in the <i>Flash Loader Development Guide</i> .
<code>__registerMacroFile</code>	Registers macros from the specified file
<code>__resetFile</code>	Rewinds a file opened by <code>__openFile</code>
<code>__restoreSoftwareBreakpoint</code> <code>s</code>	Restores any breakpoints that were destroyed during system startup.
<code>__selectCore</code>	Switches focus from the current core to the specified core.
<code>__setCodeBreak</code>	Sets a code breakpoint
<code>__setDataBreak</code>	Sets a data breakpoint
<code>__setDataLogBreak</code>	Sets a data log breakpoint
<code>__setLogBreak</code>	Sets a log breakpoint
<code>__setSimBreak</code>	Sets a simulation breakpoint
<code>__setTraceStartBreak</code>	Sets a trace start trigger breakpoint
<code>__setTraceStopBreak</code>	Sets a trace stop trigger breakpoint
<code>__sourcePosition</code>	Returns the file name and source location if the current execution location corresponds to a source location
<code>__strFind</code>	Searches a given string for the occurrence of another string
<code>__subString</code>	Extracts a substring from another string
<code>__system1</code>	Starts an external application
<code>__system2</code>	Starts an external application with <code>stdout</code> and <code>stderr</code> collected in one variable
<code>__system3</code>	Starts an external application with <code>stdout</code> and <code>stderr</code> collected in separate variables
<code>__targetDebuggerVersion</code>	Returns the version of the target debugger
<code>__toLower</code>	Returns a copy of the parameter string where all the characters have been converted to lower case

Table 16: Summary of system macros (Continued)

Macro	Description
<code>__toString</code>	Prints strings
<code>__toUpper</code>	Returns a copy of the parameter string where all the characters have been converted to upper case
<code>__unloadImage</code>	Unloads a debug image
<code>__wallTime_ms</code>	Returns the current host computer CPU time in milliseconds
<code>__whichCore</code>	Returns the currently running core.
<code>__writeAPReg</code>	Writes to an AP register
<code>__writeDPReg</code>	Writes to a DP register
<code>__writeFile</code>	Writes to the specified file
<code>__writeFileByte</code>	Writes one byte to the specified file
<code>__writeMemory8,</code> <code>__writeMemoryByte</code>	Writes one byte to the specified memory location
<code>__writeMemory16</code>	Writes a two-byte word to the specified memory location
<code>__writeMemory32</code>	Writes a four-byte word to the specified memory location
<code>__writeMemory64</code>	Writes an eight-byte word to the specified memory location
<code>__writeMemoryBuffer</code>	Writes bytes from a buffer. See the documentation in the <i>Flash Loader Development Guide</i> .

Table 16: Summary of system macros (Continued)

## **\_\_abortLaunch**

Syntax	<code>__abortLaunch(message)</code>
Parameters	<i>message</i> A string that is printed as an error message when the macro executes.
Return value	None.
For use with	All C-SPY drivers.
Description	This macro can be used for aborting a debugger launch, for example if another macro sees that something goes wrong during initialization and cannot perform a proper setup.

This is an emergency stop when launching, not a way to end an ongoing debug session like the C library function `abort()`.

**Example**

```
if (!__messageBoxYesCancel("Do you want to mass erase to unlock
                           the device?", "Unlocking device"))
{ __abortLaunch("Unlock canceled. Debug session cannot
                continue."); }
```

**\_\_cancelAllInterrupts**

Syntax	<code>__cancelAllInterrupts()</code>
Return value	<code>int 0</code>
For use with	The C-SPY Simulator. (Not available for all cores and devices.)
Description	Cancels all ordered interrupts.

**\_\_cancelInterrupt**

Syntax	<code>__cancelInterrupt(<i>interrupt_id</i>)</code>
Parameters	<i>interrupt_id</i> The value returned by the corresponding <code>__orderInterrupt</code> macro call (unsigned long).

## Return value

Result	Value
Successful	<code>int 0</code>
Unsuccessful	Non-zero error number

Table 17: `__cancelInterrupt` return values

For use with	The C-SPY Simulator. (Not available for all cores and devices.)
Description	Cancels the specified interrupt.

**\_\_clearBreak**

Syntax	<code>__clearBreak(<i>break_id</i>)</code>
Parameters	<i>break_id</i> The value returned by any of the set breakpoint macros.
Return value	<code>int 0</code>
For use with	All C-SPY drivers.
Description	Clears a user-defined breakpoint.
See also	<i>Breakpoints</i> , page 125.

**\_\_closeFile**

Syntax	<code>__closeFile(<i>fileHandle</i>)</code>
Parameters	<i>fileHandle</i> A macro variable used as filehandle by the <code>__openFile</code> macro.
Return value	<code>int 0</code>
For use with	All C-SPY drivers.
Description	Closes a file previously opened by <code>__openFile</code> .

**\_\_delay**

Syntax	<code>__delay(<i>value</i>)</code>
Parameters	<i>value</i> The number of milliseconds to delay execution.
Return value	<code>int 0</code>
For use with	All C-SPY drivers.
Description	Delays execution the specified number of milliseconds.

## \_\_disableInterrupts

Syntax `__disableInterrupts()`

Return value

Result	Value
Successful	int 0
Unsuccessful	Non-zero error number

Table 18: `__disableInterrupts` return values

For use with The C-SPY Simulator. (Not available for all cores and devices.)

Description Disables the generation of interrupts.

## \_\_driverType

Syntax `__driverType(driver_id)`

Parameters

*driver\_id*

A string corresponding to the driver you want to check for. Choose one of these:

"sim" corresponds to the simulator driver

"cadi" corresponds to the C-SPY CADI driver

"cmsisdap" corresponds to the C-SPY CMSIS-DAP driver

"e2" corresponds to the C-SPY E2 driver

"gdbserv" corresponds to the C-SPY GDB Server driver

"generic" corresponds to third-party drivers

"g+link pro" corresponds to the G+LINK driver

"ijet" corresponds to the C-SPY I-jet driver

"jlink" corresponds to the C-SPY J-Link/J-Trace driver

"lmiftdi" corresponds to the C-SPY TI Stellaris driver

"mspfet" corresponds to the C-SPY MSP-FET driver

"nulink" corresponds to the C-SPY Nu-Link driver

"xds" corresponds to the C-SPY TI XDS driver

"stlink" corresponds to the C-SPY ST-LINK driver

Return value

Result	Value
Successful	1
Unsuccessful	0

Table 19: `__driverType` return values

For use with

All C-SPY drivers.

Description

Checks to see if the current C-SPY driver is identical to the driver type of the `driver_id` parameter.

Example

`__driverType("sim")`

If the simulator is the current driver, the value 1 is returned. Otherwise 0 is returned.

## `__emulatorSpeed`

Syntax

`__emulatorSpeed(speed)`

Parameters

`speed`

The emulator speed in Hz. Use 0 (zero) to make the speed automatically detected. Use -1 for adaptive speed (only for emulators supporting adaptive speed).

Return value

Result	Value
Successful	The previous speed, or 0 (zero) if unknown
Unsuccessful. The speed is not supported by the emulator	-1

Table 20: `__emulatorSpeed` return values

For use with

The C-SPY hardware drivers.

Description

Sets the emulator clock frequency. For JTAG interfaces, this is the JTAG clock frequency as seen on the TCK signal.

Example

`__emulatorSpeed(0)`

Sets the emulator speed to be automatically detected.



## \_\_emulatorStatusCheckOnRead

Syntax	<code>__emulatorStatusCheckOnRead(<i>status</i>)</code>	
Parameters	<i>status</i>	Use 0 to enable checks (default). Use 1 to disable checks.
Return value	<code>int 0</code>	
For use with	The C-SPY J-Link/J-Trace driver.	
Description	<p>Enables or disables the driver verification of CPSR (current processor status register) after each read operation. Typically, this macro can be used for initiating JTAG connections on some CPUs, like Texas Instruments' TMS470R1B1M.</p> <p><b>Note:</b> Enabling this verification can cause problems with some CPUs, for example if invalid CPSR values are returned. However, if this verification is disabled (<code>SetCheckModeAfterRead = 0</code>), the success of read operations cannot be verified and possible data aborts are not detected.</p> <p>For the C-SPY I-jet/JTAG-jet driver, this macro is recognized, but has no effect.</p>	
Example	<pre>__emulatorStatusCheckOnRead(1)</pre> <p>Disables the checks for data aborts on memory reads.</p>	

## \_\_enableInterrupts

Syntax	<code>__enableInterrupts()</code>							
Return value	<table border="1"> <thead> <tr> <th>Result</th> <th>Value</th> </tr> </thead> <tbody> <tr> <td>Successful</td> <td><code>int 0</code></td> </tr> <tr> <td>Unsuccessful</td> <td>Non-zero error number</td> </tr> </tbody> </table>		Result	Value	Successful	<code>int 0</code>	Unsuccessful	Non-zero error number
Result	Value							
Successful	<code>int 0</code>							
Unsuccessful	Non-zero error number							
	<i>Table 21: __enableInterrupts return values</i>							
For use with	The C-SPY Simulator. (Not available for all cores and devices.)							
Description	Enables the generation of interrupts.							

## \_\_evaluate

Syntax	<code>__evaluate(string, valuePtr)</code>
Parameters	<p><i>string</i> Expression string.</p> <p><i>valuePtr</i> Pointer to a macro variable storing the result.</p>

### Return value

Result	Value
Successful	int 0
Unsuccessful	int 1

Table 22: \_\_evaluate return values

For use with	All C-SPY drivers.
Description	This macro interprets the input string as an expression and evaluates it. The result is stored in a variable pointed to by <i>valuePtr</i> .
Example	<p>This example assumes that the variable <i>i</i> is defined and has the value 5:</p> <pre>__evaluate("i + 3", &amp;myVar)</pre> <p>The macro variable <i>myVar</i> is assigned the value 8.</p>

## \_\_expandVar

Syntax	<code>__expandVar(argvar)</code>
Parameters	<p><i>argvar</i> A string that contains one or more predefined or custom argument variables for paths or arguments, for example an installation directory or an argument to a tool.</p>

### Return value

Result	Value
Successful	The string, with the argument variables expanded.
Unsuccessful	If any of the variables in the argument are not recognized, the return value is an empty string.

Table 23: \_\_expandVar return values

For use with	All C-SPY drivers.
Description	Expands any Embedded Workbench argument variables—such as \$PROJ_DIR\$ or \$PROJ_FNAME\$—contained in a string argument.
Example	<pre>__expandVar (" \$PROJ_DIR\$ ")</pre> <p>returns, for example,</p> <pre>D: \Documents\myProject</pre> <p>and</p> <pre>__expandVar (" \$TOOLKIT_DIR\$ \projects\ \$PROJ_FNAME\$.txt ")</pre> <p>returns, for example,</p> <pre>D: \Applications\IAR\Embedded Workbench\projects\myproj.txt</pre>
See also	Information about argument variables in the <i>IDE Project Management and Building Guide for Arm</i> .

## **\_\_fillMemory8**

Syntax	<code>__fillMemory8(<i>value</i>, <i>address</i>, <i>zone</i>, <i>length</i>, <i>format</i>)</code>
Parameters	<p><i>value</i></p> <p>An integer that specifies the value.</p> <p><i>address</i></p> <p>An integer that specifies the memory start address.</p> <p><i>zone</i></p> <p>A string that specifies the memory zone, see <i>C-SPY memory zones</i>, page 165.</p> <p><i>length</i></p> <p>An integer that specifies how many bytes are affected.</p> <p><i>format</i></p> <p>A string that specifies the exact fill operation to perform. Choose between:</p> <p><code>COPY</code>      <i>value</i> will be copied to the specified memory area.</p> <p><code>AND</code>        An AND operation will be performed between <i>value</i> and the existing contents of memory before writing the result to memory.</p>

	OR	An OR operation will be performed between <i>value</i> and the existing contents of memory before writing the result to memory.
	XOR	An XOR operation will be performed between <i>value</i> and the existing contents of memory before writing the result to memory.
Return value	int 0	
For use with	All C-SPY drivers.	
Description	Fills a specified memory area with a byte value.	
Example	<code>__fillMemory8(0x80, 0x700, "Memory", 0x10, "OR");</code>	

## **\_\_fillMemory16**

Syntax	<code>__fillMemory16(<i>value</i>, <i>address</i>, <i>zone</i>, <i>length</i>, <i>format</i>)</code>	
Parameters	<i>value</i>	An integer that specifies the value.
	<i>address</i>	An integer that specifies the memory start address.
	<i>zone</i>	A string that specifies the memory zone, see <i>C-SPY memory zones</i> , page 165.
	<i>length</i>	An integer that defines how many 2-byte entities to be affected.
	<i>format</i>	A string that specifies the exact fill operation to perform. Choose between:
	Copy	<i>value</i> will be copied to the specified memory area.
	AND	An AND operation will be performed between <i>value</i> and the existing contents of memory before writing the result to memory.
	OR	An OR operation will be performed between <i>value</i> and the existing contents of memory before writing the result to memory.
	XOR	An XOR operation will be performed between <i>value</i> and the existing contents of memory before writing the result to memory.

Return value	<code>int 0</code>
For use with	All C-SPY drivers.
Description	Fills a specified memory area with a 2-byte value.
Example	<code>__fillMemory16(0xCDCD, 0x7000, "Memory", 0x200, "Copy");</code>

## **\_\_fillMemory32**

Syntax	<code>__fillMemory32(<i>value</i>, <i>address</i>, <i>zone</i>, <i>length</i>, <i>format</i>)</code>								
Parameters	<p><i>value</i> An integer that specifies the value.</p> <p><i>address</i> An integer that specifies the memory start address.</p> <p><i>zone</i> A string that specifies the memory zone, see <i>C-SPY memory zones</i>, page 165.</p> <p><i>length</i> An integer that defines how many 4-byte entities to be affected.</p> <p><i>format</i> A string that specifies the exact fill operation to perform. Choose between:</p> <table> <tr> <td>Copy</td> <td><i>value</i> will be copied to the specified memory area.</td> </tr> <tr> <td>AND</td> <td>An AND operation will be performed between <i>value</i> and the existing contents of memory before writing the result to memory.</td> </tr> <tr> <td>OR</td> <td>An OR operation will be performed between <i>value</i> and the existing contents of memory before writing the result to memory.</td> </tr> <tr> <td>XOR</td> <td>An XOR operation will be performed between <i>value</i> and the existing contents of memory before writing the result to memory.</td> </tr> </table>	Copy	<i>value</i> will be copied to the specified memory area.	AND	An AND operation will be performed between <i>value</i> and the existing contents of memory before writing the result to memory.	OR	An OR operation will be performed between <i>value</i> and the existing contents of memory before writing the result to memory.	XOR	An XOR operation will be performed between <i>value</i> and the existing contents of memory before writing the result to memory.
Copy	<i>value</i> will be copied to the specified memory area.								
AND	An AND operation will be performed between <i>value</i> and the existing contents of memory before writing the result to memory.								
OR	An OR operation will be performed between <i>value</i> and the existing contents of memory before writing the result to memory.								
XOR	An XOR operation will be performed between <i>value</i> and the existing contents of memory before writing the result to memory.								
Return value	<code>int 0</code>								
For use with	All C-SPY drivers.								

Description Fills a specified memory area with a 4-byte value.

Example `__fillMemory32(0x0000FFFF, 0x4000, "Memory", 0x1000, "XOR");`

## **\_\_fillMemory64**

Syntax `__fillMemory64(value, address, zone, length, format)`

Parameters

*value*

An integer that specifies the value.

*address*

An integer that specifies the memory start address.

*zone*

A string that specifies the memory zone, see *C-SPY memory zones*, page 165.

*length*

An integer that defines how many 8-byte entities to be affected.

*format*

A string that specifies the exact fill operation to perform. Choose between:

<code>COPY</code>	<i>value</i> will be copied to the specified memory area.
<code>AND</code>	An AND operation will be performed between <i>value</i> and the existing contents of memory before writing the result to memory.
<code>OR</code>	An OR operation will be performed between <i>value</i> and the existing contents of memory before writing the result to memory.
<code>XOR</code>	An XOR operation will be performed between <i>value</i> and the existing contents of memory before writing the result to memory.

Return value `int 0`

For use with All C-SPY drivers.

Description Fills a specified memory area with an 8-byte value.

Example `__fillMemory64(0x0155'FFFF'FFFF'FFFF, 0x4000, "Memory", 0x1000, "AND");`

## \_\_gdbserver\_exec\_command

Syntax	<code>__gdbserver_exec_command("string")</code>	
Parameters	<i>string</i>	String or command sent to the GDB Server. For more information, see the GDB server documentation.
For use with	The C-SPY GDB Server driver.	
Description	Use this option to send strings or commands to the GDB Server.	

## \_\_getNumberOfCores

Syntax	<code>__getNumberOfCores()</code>	
Return value	The number of local cores being debugged.	
For use with	The C-SPY simulator. (Not available for all cores and devices.) The C-SPY I-jet driver.	
Description	This macro returns the number of local cores being debugged.	
Example	<pre>test () {     __var i;     for (i = 0; i &lt; __getNumberOfCores(); i++ )     {         __selectCore(i);         __message "Core: ", __getSelectedCore(), " pc = ", #PC:%x, "\n";     } }</pre>	
See also	<code>__getSelectedCore</code> , page 459 and <code>__selectCore</code> , page 485	

## \_\_getSelectedCore

Syntax	<code>__getSelectedCore()</code>	
Return value	The current core. The cores are numbered from 0 and upwards.	

For use with	The C-SPY simulator. (Not available for all cores and devices.) The C-SPY I-jet driver.
Description	Gets the number of the current core.
Example	<pre>test () {   __message "Core: ", __getSelectedCore(), " pc = ", #PC:%x,   "\n";   __selectCore(0);   __message "Core: ", __getSelectedCore(), " pc = ", #PC:%x,   "\n";   __selectCore(1);   __message "Core: ", __getSelectedCore(), " pc = ", #PC:%x,   "\n"; }</pre> <p>A typical result of the above macro would be (assuming that the original core was number 1):</p> <pre>Core: 1 pc = 0000213C Core: 0 pc = 00000494 Core: 1 pc = 0000213C</pre>
See also	<code>__selectCore</code> , page 485.

## `__getTracePortSize`

Syntax	<code>__getTracePortSize</code>				
Return value	<table border="1"> <thead> <tr> <th>Result</th> <th>Value</th> </tr> </thead> <tbody> <tr> <td>The width of the trace port in bits.</td> <td>1, 2, 4, 8, or 16.</td> </tr> </tbody> </table> <p><i>Table 24: <code>__getTracePortSize</code> return values</i></p>	Result	Value	The width of the trace port in bits.	1, 2, 4, 8, or 16.
Result	Value				
The width of the trace port in bits.	1, 2, 4, 8, or 16.				
For use with	The C-SPY I-jet driver. The C-SPY J-Link/J-Trace driver.				
Description	Returns the width of the trace port.				
See also	<i>ETM Trace Settings dialog box (I-jet)</i> , page 219 and <i>ETM Trace Settings dialog box (J-Link/J-Trace)</i> , page 221, respectively.				



## \_\_hasDAPRegs

Syntax `__hasDAPRegs()`

Return value

Result	Value
The C-SPY driver supports the macros <code>__readAPReg</code> , <code>__readDPReg</code> , <code>__writeAPReg</code> , and <code>__writeDPReg</code> for the current CPU core.	true
The C-SPY driver does not support the macros <code>__readAPReg</code> , <code>__readDPReg</code> , <code>__writeAPReg</code> , and <code>__writeDPReg</code> for the current CPU core.	false

Table 25: `__hasDAPRegs` return values

For use with The C-SPY hardware drivers.

Description This macro returns true if the C-SPY driver supports the macros `__readAPReg`, `__readDPReg`, `__writeAPReg`, and `__writeDPReg` for the current CPU core, otherwise it returns false.

## \_\_hwJetResetWithStrategy

Syntax `__hwJetResetWithStrategy(halt_delay, strategy)`

Parameters

<i>halt_delay</i>	The delay, in milliseconds, between the end of the reset pulse and the halt of the CPU. Use 0 (zero) to make the CPU halt immediately after reset—only when <i>strategy</i> is set to 0.
<i>strategy</i>	The reset strategy number. For information about supported reset strategies, see <code>--jet_standard_reset</code> , page 553.

Return value

Result	Value
Successful. The delay feature is not supported by the debugging probe	-1
Unsuccessful. The reset strategy is not supported by the debugging probe	-3
Unsuccessful. Other	-4

Table 26: `__hwJetResetWithStrategy` return values

For use with The C-SPY I-jet driver.

Description Specifies the reset strategy to perform.

Example `__hwJetResetWithStrategy(0, 2)`  
Performs a hardware reset.

## **\_\_hwReset**

Syntax `__hwReset(halt_delay)`

Parameters

*halt\_delay* The delay, in milliseconds, between the end of the reset pulse and the halt of the CPU. Use 0 (zero) to make the CPU halt immediately after reset

Return value

Result	Value
Successful. The actual delay value implemented by the emulator	>=0
Successful. The delay feature is not supported by the emulator	-1
Unsuccessful. Hardware reset is not supported by the emulator	-2

Table 27: `__hwReset` return values

For use with This system macro is available for all JTAG interfaces.

Description Performs a hardware reset and halt of the target CPU.

Example `__hwReset(0)`  
Resets the CPU and immediately halts it.

## **\_\_hwResetRunToBp**

Syntax `__hwResetRunToBp(strategy, breakpoint_address, timeout)`

Parameters

*strategy* For information about supported reset strategies in the C-SPY I-jet driver, see `--jet_standard_reset`, page 553.  
For information about supported reset strategies in the C-SPY J-Link driver, see the *IAR J-Link and IAR J-Trace User Guide for JTAG Emulators for ARM Cores*.

*breakpoint\_address* The address of the breakpoint to execute to, specified as an integer value (symbols cannot be used).

*timeout* A time out for the breakpoint, specified in milliseconds. If the breakpoint is not reached within the specified time, the core will be halted.

#### Return value

Value	Result
>=0	Successful. The approximate execution time in ms until the breakpoint is hit.
-2	Unsuccessful. Hardware reset is not supported by the emulator.
-3	Unsuccessful. The reset strategy is not supported by the emulator.

Table 28: `__hwResetRunToBp` return values

#### For use with

The C-SPY CMSIS-DAP driver.  
 The C-SPY I-jet driver.  
 The C-SPY J-Link/J-Trace driver.

#### Description

Performs a hardware reset, sets a breakpoint at the specified address, executes to the breakpoint, and then removes it. The breakpoint address should be the start address of the downloaded image after it has been copied to RAM.

This macro is intended for running a boot loader that copies the application image from flash to RAM. The macro should be executed after the image has been downloaded to flash, but before the image is verified. The macro can be run in `execUserFlashExit` or `execUserPreload`.

#### Example

```
__hwResetRunToBp(0, 0x400000, 10000)
```

Resets the CPU with the reset strategy 0 and executes to the address 0x400000. If the breakpoint is not reached within 10 seconds, execution stops in accordance with the specified time out.

## \_\_hwResetWithStrategy

Syntax `__hwResetWithStrategy(halt_delay, strategy)`

### Parameters

*halt\_delay* The delay, in milliseconds, between the end of the reset pulse and the halt of the CPU. Use 0 (zero) to make the CPU halt immediately after reset—only when *strategy* is set to 0.

*strategy* The C-SPY I-jet driver only supports strategy 2 (hardware reset). For information about supported reset strategies in the C-SPY J-Link driver, see the *J-Link/J-Trace User Guide*.

### Return value

Result	Value
Successful. The actual delay in milliseconds, as implemented by the emulator	$\geq 0$
Successful. The delay feature is not supported by the emulator	-1
Unsuccessful. Hardware reset is not supported by the emulator	-2
Unsuccessful. The reset strategy is not supported by the emulator	-3

Table 29: \_\_hwResetWithStrategy return values

### For use with

The C-SPY I-jet driver.

The C-SPY J-Link/J-Trace driver.

This macro also exists in other C-SPY hardware drivers, but has no effect.

### Description

Performs a hardware reset and a halt with delay of the target CPU.

### Example

```
__hwResetWithStrategy(0, 1)
```

Resets the CPU and halts it using a breakpoint at memory address zero.

## \_\_hwRunToBreakpoint

Syntax `__hwRunToBreakpoint(breakpoint_address, timeout)`

### Parameters

*breakpoint\_address* The address of the breakpoint to execute to, specified as an integer value (symbols cannot be used).

*timeout* A time out for the breakpoint, specified in milliseconds. If the breakpoint is not reached within the specified time, the core will be halted.

Return value

Value	Result
>=0	Successful. The approximate execution time in ms until the breakpoint is hit.
-1	Failed to set the breakpoint.
-2	Failed to stop at the breakpoint before timeout.

Table 30: *\_\_hwRunToBreakpoint* return values

For use with

The C-SPY CMSIS-DAP driver.  
 The C-SPY I-jet driver.  
 The C-SPY J-Link/J-Trace driver.  
 The C-SPY PE micro driver.  
 The C-SPY ST-LINK driver.  
 The C-SPY TI XDS driver.

Description

Use this macro to set a temporary breakpoint and then start the execution. When the breakpoint is triggered, the execution stops. This macro can be used for running initialization code on the target system.

Example

```
__hwRunToBreakpoint(0x20000048, 1000)
```

Sets a temporary breakpoint at the address 0x20000048, starts executing, and executes until the breakpoint is triggered or until 1000 milliseconds have passed.

## **\_\_isBatchMode**

Syntax

```
__isBatchMode()
```

Return value

Result	Value
True	int 1
False	int 0

Table 31: *\_\_isBatchMode* return values

For use with

All C-SPY drivers.

Description	This macro returns True if the debugger is running in batch mode, otherwise it returns False.
-------------	---

## **\_\_isMacroSymbolDefined**

Syntax	<code>__isMacroSymbolDefined(<i>symbol</i>)</code>
Parameters	<i>symbol</i> The name of a C-SPY macro variable or macro function (a string).
Return value	1 if <i>symbol</i> is an existing macro symbol. 0 if <i>symbol</i> is not defined.
For use with	All C-SPY drivers.
Description	This macro identifies whether a string is the name of an existing C-SPY macro symbol (variable or function) or not.
Example	<pre>__var someVariable; ... if (__isMacroSymbolDefined("someVariable"))     someVariable = 42; else     __message "The someVariable symbol is not defined!";</pre>

## **\_\_jlinkExecCommand**

Syntax	<code>__jlinkExecCommand(<i>cmdstr</i>)</code>
Parameters	<i>cmdstr</i> J-Link/J-Trace command string
Return value	int 0
For use with	The C-SPY J-Link/J-Trace driver.
Description	Sends a low-level command to the J-Link/J-Trace driver. For a list of possible commands, see the <i>J-Link/J-Trace User Guide</i> .
Example	See the <i>J-Link/J-Trace User Guide</i> .

See also [--jlink\\_exec\\_command](#), page 557

## \_\_jlinkExecMacro

Syntax	<code>__jlinkExecMacro(<i>function</i>)</code>	
Parameters	<i>function</i>	A string that defines a name of the function in a J-Link script.
Return value	An unsigned integer	The return value from the J-Link script function.
For use with	The C-SPY J-Link driver.	
Description	Calls a function (without any parameters) in a J-Link script file.	
Example	<code>__jlinkExecMacro("myfunction");</code>	
See also	See the <i>J-Link/J-Trace User Guide</i> .	

## \_\_jtagCommand

Syntax	<code>__jtagCommand(<i>ir</i>)</code>	
Parameters	<i>ir</i> can be one of:	
	2	SCAN_N
	4	RESTART
	12	INTEST
	14	IDCODE
	15	BYPASS
Return value	int 0	
For use with	The C-SPY J-Link/J-Trace driver.	
Description	Sends a low-level command to the JTAG instruction register IR.	

**Example**

```
__jtagCommand(14);
Id = __jtagData(0, 32);
```

Returns the JTAG ID of the Arm target device.

## **\_\_jtagCP15IsPresent**

**Syntax** `__jtagCP15IsPresent()`

**Return value** 1 if CP15 is available, otherwise 0.

**For use with** The C-SPY I-jet driver.  
The C-SPY J-Link/J-Trace driver.

**Description** Checks if the coprocessor CP15 is available.

## **\_\_jtagCP15ReadReg**

**Syntax** `__jtagCP15ReadReg(CRn, CRm, op1, op2)`

**ParametersParameter** The parameters—registers and operands—of the MRC instruction. For details, see the *ARM Architecture Reference Manual*. Note that *op1* should always be 0.

**Return value** The register value.

**For use with** The C-SPY I-jet driver.  
The C-SPY J-Link/J-Trace driver.

**Description** Reads the value of the CP15 register and returns its value.

## **\_\_jtagCP15WriteReg**

**Syntax** `__jtagCP15WriteReg(CRn, CRm, op1, op2, value)`

**Parameters** The parameters—registers and operands—of the MCR instruction. For details, see the *ARM Architecture Reference Manual*. Note that *op1* should always be 0. *value* is the value to be written.

**Applicability** The C-SPY I-jet driver.  
The C-SPY J-Link/J-Trace driver.



Description Writes a value to the CP15 register.

## \_\_jtagData

Syntax `__jtagData(dr, bits)`

### Parameters

<i>dr</i>	32-bit data register value
<i>bits</i>	Number of valid bits in <i>dr</i> , both for the macro parameter and the return value—starting with the least significant bit (1...32)

Return value Returns the result of the operation—the number of bits in the result is given by the *bits* parameter.

For use with The C-SPY J-Link/J-Trace driver.

Description Sends a low-level data value to the JTAG data register DR. The bit shifted out of DR is returned.

Example

```
__jtagCommand(14);
Id = __jtagData(0,32);
```

Returns the JTAG ID of the Arm target device.

## \_\_jtagRawRead

Syntax `__jtagRawRead(bitpos, numbits)`

### Parameters

<i>bitpos</i>	The start bit position in the returned JTAG bits to return data from
<i>numbits</i>	The number of bits to read. The maximum value is 32.

For use with The C-SPY J-Link/J-Trace driver.

Description Returns the data read from the JTAG TDO. Only the least significant bits contain data—the last bit read is from the least significant bit. This function can be called an arbitrary number of times to get all bits returned by an operation. This function also makes an implicit synchronization of any accumulated write bits.

**Example**

The following piece of pseudocode illustrates how the data is written to the JTAG (on the TMS and TDI pins) and read (from TDO):

```

__var Id;
__var BitPos;
/*****
*
* ReadId()
*/
ReadId() {
__message "Reading JTAG Id\n";
__jtagRawWrite(0, 0x1f, 6); /* Goto IDLE via RESET state */
__jtagRawWrite(0, 0x1, 3); /* Enter DR scan chain */
BitPos = __jtagRawWrite(0, 0x80000000, 32); /* Shift 32 bits
      into DR. Remember BitPos for Read operation */
__jtagRawWrite(0, 0x1, 2); /* Goto IDLE */
Id = __jtagRawRead(BitPos, 32); /* Read the Id */
__message "JTAG Id: ", Id:%x, "\n";
}

```

**\_\_jtagRawSync****Syntax**

```
__jtagRawSync()
```

**Return value**

```
int 0
```

**For use with**

The C-SPY J-Link/J-Trace driver.

**Description**

Sends arbitrary data to the JTAG interface. All accumulated bits using `__jtagRawWrite` will be written to the JTAG scan chain. The data is sent synchronously with TCK and typically sampled by the device on rising edge of TCK.

**Example**

The following piece of pseudocode illustrates how the data is written to the JTAG (on the TMS and TDI pins) and read (from TDO):

```
int i;
U32 tdo;
for (i = 0; i < numBits; i++) {
    TDI = tdi & 1; /* Set TDI pin */
    TMS = tms & 1; /* Set TMS pin */
    TCK = 0;
    TCK = 1;
    tdo <<= 1;
    if (TDO) {
        tdo |= 1;
    }
    tdi >>= 1;
    tms >>= 1;
}
```

**\_\_jtagRawWrite****Syntax**

```
__jtagRawWrite(tdi, tms, numbits)
```

**Parameters**

<i>tdi</i>	The data output to the TDI pin. This data is sent with the least significant bit first.
<i>tms</i>	The data output to the TMS pin. This data is sent with the least significant bit first.
<i>numbits</i>	The number of bits to transfer. Every bit results in a falling and rising edge of the JTAG TCK line. The maximum value is 64.

**Return value**

Returns the bit position of the data in the accumulated packet. Typically, this value is used when reading data from the JTAG.

**For use with**

The C-SPY J-Link/J-Trace driver.

**Description**

Accumulates bits to be transferred to the JTAG. If 32 bits are not enough, this function can be called multiple times. Both data output lines (TMS and TDI) can be controlled separately.

## Example

```
/* Send five 1 bits on TMS to go to TAP-RESET state */
__jtagRawWrite(0x1F, 0, 5); /* Store bits in buffer */
__jtagRawSync(); /* Transfer buffer, writing tms, tdi,
                    reading tdo */
```

Returns the JTAG ID of the Arm target device.

**\_\_jtagResetTRST**

## Syntax

```
__jtagResetTRST()
```

## Return value

Result	Value
Successful	int 0
Unsuccessful	Non-zero error number

Table 32: \_\_jtagResetTRST return values

## For use with

The C-SPY J-Link/J-Trace driver.

## Description

Resets the Arm TAP controller via the TRST JTAG signal.

**\_\_loadImage**

## Syntax

```
__loadImage(path, offset, debugInfoOnly)
```

## Parameters

*path*

A string that identifies the path to the debug image to download. The path must either be absolute or use argument variables. For information about argument variables, see the *IDE Project Management and Building Guide for Arm*.

*offset*

An integer that identifies the offset to the destination address for the downloaded debug image.

*debugInfoOnly*

A non-zero integer value if no code or data should be downloaded to the target system, which means that C-SPY will only read the debug information from the debug file. Or, 0 (zero) for download.

Return value

Value	Result
Non-zero integer number	A unique module identification.
int 0	Loading failed.

Table 33: `__loadImage` return values

For use with

All C-SPY drivers.

Description

Loads a debug image (debug file).

**Note:** Images are only downloaded to RAM and no flash loading will be performed, unless you are using J-Link or TI MSP-FET.

Example 1

Your system consists of a ROM library and an application. The application is your active project, but you have a debug file corresponding to the library. In this case you can add this macro call in the `execUserSetup` macro in a C-SPY macro file, which you associate with your project:

```
__loadImage("ROMfile", 0x8000, 1);
```

This macro call loads the debug information for the ROM library `ROMfile` without downloading its contents (because it is presumably already in ROM). Then you can debug your application together with the library.

Example 2

Your system consists of a ROM library and an application, but your main concern is the library. The library needs to be programmed into flash memory before a debug session. While you are developing the library, the library project must be the active project in the IDE. In this case you can add this macro call in the `execUserSetup` macro in a C-SPY macro file, which you associate with your project:

```
__loadImage("ApplicationFile", 0x8000, 0);
```

The macro call loads the debug information for the application and downloads its contents (presumably into RAM). Then you can debug your library together with the application.

See also

*Images*, page 587 and *Loading multiple debug images*, page 59.

## `__memoryRestore`

Syntax

```
__memoryRestore(zone, filename, offset)
```

Parameters

*zone*

A string that specifies the memory zone, see *C-SPY memory zones*, page 165.

	<i>filename</i>
	A string that specifies the file to be read. The filename must include a path, which must either be absolute or use argument variables. For information about argument variables, see the <i>IDE Project Management and Building Guide for Arm</i> .
	<i>offset</i>
	An integer offset. When restoring data from the file into memory, this offset is added to the addresses specified in the file. For example, if the file contains data from 0x0–0x1FF and the offset is 0x400, the data will be placed in memory in the range 0x400–0x5FF. This makes it possible to restore data into memory on addresses larger than 32-bit, even if the file format only supports 32-bit addresses.
Return value	int 0
For use with	All C-SPY drivers.
Description	Reads the contents of a file and saves it to the specified memory zone.
Example	<code>__memoryRestore("Memory", "c:\\temp\\saved_mem.hex", 0x400);</code>
See also	<i>Memory Restore dialog box</i> , page 177.

## **\_\_memorySave**

Syntax	<code>__memorySave(start, stop, format, filename, zerostart)</code>
Parameters	<p><i>start</i></p> <p>A string that specifies the first location of the memory area to be saved.</p> <p><i>stop</i></p> <p>A string that specifies the last location of the memory area to be saved.</p> <p><i>format</i></p> <p>A string that specifies the format to be used for the saved memory. Choose between:</p> <p>intel-extended</p> <p>motorola</p> <p>motorola-s19</p> <p>motorola-s28</p>

`motorola-s37`

*filename*

A string that specifies the file to write to. The filename must include a path, which must either be absolute or use argument variables. For information about argument variables, see the *IDE Project Management and Building Guide for Arm*.

*zerostart*

An integer. If it is 1 (or any non-zero value), the addresses in the saved file will start from 0x0. For example, if the specified memory range is 0x400–0x5FF, the address range in the file will be 0x0–0x1FF. This makes it possible to save memory from addresses larger than 32-bit to file formats which only support 32-bit addresses. If the parameter is 0, the file will contain the specified addresses as given.

Return value	<code>int 0</code>
For use with	All C-SPY drivers.
Description	Saves the contents of a specified memory area to a file.
Example	<pre>__memorySave("Memory:0x00", "Memory:0xFF", "intel-extended", "c:\\temp\\saved_memory.hex", 0);</pre>
See also	<i>Memory Save dialog box</i> , page 176.

## \_\_messageBoxYesCancel

Syntax	<code>__messageBoxYesCancel(message, caption)</code>
Parameters	<p><i>message</i></p> <p>A message that will appear in the message box.</p> <p><i>caption</i></p> <p>The title that will appear in the message box.</p>
Return value	

Result	Value
Yes	1
No	0

Table 34: `__messageBoxYesCancel` return values

For use with	All C-SPY drivers.
Description	Displays a Yes/Cancel dialog box when called and returns the user input. Typically, this is useful for creating macros that require user interaction.

## \_\_messageBoxYesNo

Syntax	<code>__messageBoxYesNo(<i>message</i>, <i>caption</i>)</code>
Parameters	<p><i>message</i></p> <p>A message that will appear in the message box.</p> <p><i>caption</i></p> <p>The title that will appear in the message box.</p>

Return value

Result	Value
Yes	1
No	0

Table 35: \_\_messageBoxYesNo return values

For use with	All C-SPY drivers.
Description	Displays a Yes/No dialog box when called and returns the user input. Typically, this is useful for creating macros that require user interaction.

## \_\_openFile

Syntax	<code>__openFile(<i>filename</i>, <i>access</i>)</code>
Parameters	<p><i>filename</i></p> <p>The file to be opened. The filename must include a path, which must either be absolute or use argument variables. For information about argument variables, see the <i>IDE Project Management and Building Guide for Arm</i>.</p> <p><i>access</i></p> <p>The access type (string).</p> <p>These are mandatory but mutually exclusive:</p> <p>"a" append, new data will be appended at the end of the open file</p> <p>"r" read (by default in text mode; combine with <code>b</code> for binary mode: <code>rb</code>)</p>



"w" write (by default in text mode; combine with b for binary mode: wb)

These are optional and mutually exclusive:

"b" binary, opens the file in binary mode

"t" ASCII text, opens the file in text mode

This access type is optional:

"+" together with r, w, or a; r+ or w+ is *read* and *write*, while a+ is *read* and *append*

Return value

Result	Value
Successful	The file handle
Unsuccessful	An invalid file handle, which tests as False

Table 36: \_\_openFile return values

For use with

All C-SPY drivers.

Description

Opens a file for I/O operations. The default base directory of this macro is where the currently open project file (\*.ewp) is located. The argument to \_\_openFile can specify a location relative to this directory. In addition, you can use argument variables such as \$PROJ\_DIR\$ and \$TOOLKIT\_DIR\$ in the path argument.

Example

```
__var myFileHandle;          /* The macro variable to contain */
                             /* the file handle */
myFileHandle = __openFile("$PROJ_DIR$\\Debug\\Exe\\test.tst",
"r");
if (myFileHandle)
{
    /* successful opening */
}
```

See also

For information about argument variables, see the *IDE Project Management and Building Guide for Arm*.

## \_\_orderInterrupt

Syntax

```
__orderInterrupt(specification, first_activation,
                 repeat_interval, variance, infinite_hold_time,
                 hold_time, probability)
```

Parameters	<p><i>specification</i> The interrupt (string). The specification can either be the full specification used in the device description file (<i>ddf</i>) or only the name. In the latter case the interrupt system will automatically get the description from the device description file.</p> <p><i>first_activation</i> The first activation time in cycles (integer)</p> <p><i>repeat_interval</i> The periodicity in cycles (integer)</p> <p><i>variance</i> The timing variation range in percent (integer between 0 and 100)</p> <p><i>infinite_hold_time</i> 1 if infinite, otherwise 0.</p> <p><i>hold_time</i> The hold time (integer)</p> <p><i>probability</i> The probability in percent (integer between 0 and 100)</p>
Return value	The macro returns an interrupt identifier (unsigned long). If the syntax of <i>specification</i> is incorrect, it returns -1.
For use with	The C-SPY simulator. (Not available for all cores and devices.)
Description	Generates an interrupt.
Example	This example generates a repeating interrupt using an infinite hold time first activated after 4000 cycles: <pre>__orderInterrupt( "IRQ", 4000, 2000, 0, 1, 0, 100 );</pre>

## **\_\_popSimulatorInterruptExecutingStack**

Syntax	<code>__popSimulatorInterruptExecutingStack(void)</code>
Return value	<code>int 0</code>
For use with	The C-SPY simulator. (Not available for all cores and devices.)

Description	<p>Informs the interrupt simulation system that an interrupt handler has finished executing, as if the normal instruction used for returning from an interrupt handler was executed.</p> <p>This is useful if you are using interrupts in such a way that the normal instruction for returning from an interrupt handler is not used, for example in an operating system with task-switching. In this case, the interrupt simulation system cannot automatically detect that the interrupt has finished executing.</p>
See also	<i>Simulating an interrupt in a multi-task system</i> , page 408.

## \_\_probeType

Syntax	<code>__probeType (probe_id)</code>						
Parameters	<p><i>probe_id</i></p> <p>A string corresponding to the probe you want to check for. Choose one of these:</p> <ul style="list-style-type: none"> <li>"I-jet" corresponds to the I-jet probe</li> <li>"I-jet-Trace" corresponds to the I-jet Trace probe.</li> </ul> <p>The strings are case-insensitive.</p>						
Return value	<table border="1"> <thead> <tr> <th>Result</th> <th>Value</th> </tr> </thead> <tbody> <tr> <td>Successful</td> <td>1</td> </tr> <tr> <td>Unsuccessful</td> <td>0</td> </tr> </tbody> </table> <p><i>Table 37: __probeType return values</i></p>	Result	Value	Successful	1	Unsuccessful	0
Result	Value						
Successful	1						
Unsuccessful	0						
For use with	The C-SPY I-jet driver.						
Description	Checks to see if the current connected probe is identical to the probe type of the <i>probe_id</i> parameter.						
Example	<pre>__probeType ("I-jet ")</pre> <p>If I-jet is the current connected probe, the value 1 is returned. Otherwise 0 is returned.</p>						

**\_\_readAPReg**

Syntax `__readAPReg(register)`

Parameters  
*register* An 8-bit AP register offset.

Return value

Result	Value
Successful	true
Unsuccessful	false

Table 38: \_\_readAPReg return values

For use with  
 The C-SPY I-jet driver.  
 The C-SPY J-Link/J-Trace driver.  
 The C-SPY TI Stellaris driver.

Description  
 Performs a read operation from an AP register of the currently selected access port.

**\_\_readDPRReg**

Syntax `__readDPRReg(register)`

Parameters  
*register* An 8-bit DP register offset.

Return value

Result	Value
Successful	true
Unsuccessful	false

Table 39: \_\_readDPRReg return values

For use with  
 The C-SPY I-jet driver.  
 The C-SPY J-Link/J-Trace driver.  
 The C-SPY TI Stellaris driver.

Description  
 Performs a read operation from a DP register.

## \_\_readFile

Syntax `__readFile(fileHandle, valuePtr)`

Parameters `fileHandle`

A macro variable used as filehandle by the `__openFile` macro.

`valuePtr`

A pointer to a variable.

Return value

Result	Value
Successful	0
Unsuccessful	Non-zero error number

Table 40: `__readFile` return values

For use with

All C-SPY drivers.

Description

Reads a sequence of hexadecimal digits from the given file and converts them to an unsigned long which is assigned to the `value` parameter, which should be a pointer to a macro variable.

Only printable characters representing hexadecimal digits and white-space characters are accepted, no other characters are allowed.

Example

```
__var number;
if (__readFile(myFileHandle, &number) == 0)
{
    // Do something with number
}
```

In this example, if the file pointed to by `myFileHandle` contains the ASCII characters `1234 abcd 90ef`, consecutive reads will assign the values `0x1234 0xabcd 0x90ef` to the variable `number`.

## \_\_readFileByte

Syntax `__readFileByte(fileHandle)`

Parameters `fileHandle`

A macro variable used as filehandle by the `__openFile` macro.

Return value

-1 upon error or end-of-file, otherwise a value between 0 and 255.

For use with	All C-SPY drivers.
Description	Reads one byte from a file.
Example	<pre> __var byte; while ( (byte = __readFileByte(myFileHandle)) != -1 ) {     /* Do something with byte */ } </pre>

## **\_\_readMemory8, \_\_readMemoryByte**

Syntax	<pre> __readMemory8(<i>address</i>, <i>zone</i>) __readMemoryByte(<i>address</i>, <i>zone</i>) </pre>
Parameters	<p><i>address</i></p> <p>The memory address (integer).</p> <p><i>zone</i></p> <p>A string that specifies the memory zone, see <i>C-SPY memory zones</i>, page 165.</p>
Return value	The macro returns the value from memory.
For use with	All C-SPY drivers.
Description	Reads one byte from a given memory location.
Example	<pre> __readMemory8(0x0108, "Memory"); </pre>

## **\_\_readMemory16**

Syntax	<pre> __readMemory16(<i>address</i>, <i>zone</i>) </pre>
Parameters	<p><i>address</i></p> <p>The memory address (integer).</p> <p><i>zone</i></p> <p>A string that specifies the memory zone, see <i>C-SPY memory zones</i>, page 165.</p>
Return value	The macro returns the value from memory.
For use with	All C-SPY drivers.

Description Reads a two-byte word from a given memory location.

Example `__readMemory16(0x0108, "Memory");`

## **\_\_readMemory32**

Syntax `__readMemory32(address, zone)`

Parameters

*address*

The memory address (integer).

*zone*

A string that specifies the memory zone, see *C-SPY memory zones*, page 165.

Return value The macro returns the value from memory.

For use with All C-SPY drivers.

Description Reads a four-byte word from a given memory location.

Example `__readMemory32(0x0108, "Memory");`

## **\_\_readMemory64**

Syntax `__readMemory64(address, zone)`

Parameters

*address*

The memory address (integer).

*zone*

A string that specifies the memory zone, see *C-SPY memory zones*, page 165.

Return value The macro returns the value from memory.

For use with All C-SPY drivers.

Description Reads an eight-byte word from a given memory location.

Example `__readMemory64(0x8000, "Memory");`

## \_\_registerMacroFile

Syntax	<code>__registerMacroFile(<i>filename</i>)</code>
Parameters	<i>filename</i> A file containing the macros to be registered (string). The filename must include a path, which must either be absolute or use argument variables. For information about argument variables, see the <i>IDE Project Management and Building Guide for Arm</i> .
Return value	int 0
For use with	All C-SPY drivers.
Description	Registers macros from a setup macro file. With this function you can register multiple macro files during C-SPY startup.
Example	<code>__registerMacroFile("c:\\testdir\\macro.mac");</code>
See also	<i>Using C-SPY macros</i> , page 429.

## \_\_resetFile

Syntax	<code>__resetFile(<i>fileHandle</i>)</code>
Parameters	<i>fileHandle</i> A macro variable used as filehandle by the <code>__openFile</code> macro.
Return value	int 0
For use with	All C-SPY drivers.
Description	Rewinds a file previously opened by <code>__openFile</code> .

## \_\_restoreSoftwareBreakpoints

Syntax	<code>__restoreSoftwareBreakpoints()</code>
Return value	int 0
For use with	All C-SPY hardware drivers.



**Description** Restores automatically any breakpoints that were destroyed during system startup.

This can be useful if you have an application that is copied to RAM during startup and is then executing in RAM. This can, for example, be the case if you use the `initialize` by `copy` directive for code in the linker configuration file or if you have any `__ramfunc` declared functions in your application. In this case, any breakpoints will be overwritten during the RAM copying when the application execution starts.

By using the this macro, C-SPY will restore the destroyed breakpoints.

## **\_\_selectCore**

**Syntax** `__selectCore(int core)`

**Parameters** `core`  
The core to switch to. The cores are numbered from 0 and upwards.

**Return value** `int 0`

**For use with** The C-SPY simulator. (Not available for all cores and devices.)  
The C-SPY I-jet driver.

**Description** Switches focus from the current core to the specified core for the duration of the macro invocation or until any next invocation of `__selectCore`.

**Example**

```
test ()
{
    __message "Core: ", __getSelectedCore(), " pc = ", #PC:%x,
    "\n";
    __selectCore(0);
    __message "Core: ", __getSelectedCore(), " pc = ", #PC:%x,
    "\n";
    __selectCore(1);
    __message "Core: ", __getSelectedCore(), " pc = ", #PC:%x,
    "\n";
}
```

A typical result of the above macro would be (assuming that the original core was number 1):

```
Core: 1 pc = 0000213C
Core: 0 pc = 00000494
Core: 1 pc = 0000213C
```

**See also** `__getSelectedCore`, page 459.

## \_\_setCodeBreak

### Syntax

```
__setCodeBreak(location, count, condition, cond_type, action)
```

### Parameters

#### *location*

A string that defines the code location of the breakpoint, either a valid C-SPY expression whose value evaluates to a valid address, an absolute location, or a source location. For more information about the location types, see *Enter Location dialog box*, page 159.

#### *count*

An integer that specifies the number of times that a breakpoint condition must be fulfilled before a break occurs the next time.

#### *condition*

The breakpoint condition. This must be a valid C-SPY expression, for instance a C-SPY macro function.

#### *cond\_type*

The condition type; either "CHANGED" or "TRUE" (string).

#### *action*

An expression, typically a call to a macro, which is evaluated when the breakpoint is detected.

### Return value

Result	Value
Successful	An unsigned integer uniquely identifying the breakpoint. This value must be used to clear the breakpoint.
Unsuccessful	0

Table 41: \_\_setCodeBreak return values

### For use with

The C-SPY hardware debugger drivers.

### Description

Sets a code breakpoint, that is, a breakpoint which is triggered just before the processor fetches an instruction at the specified location.

### Examples

```
__setCodeBreak("{D:\\src\\prog.c}.12.9", 3, "d>16", "TRUE",  
"ActionCode()");
```

This example sets a code breakpoint on the label `main` in your source:

```
__setCodeBreak("main", 0, "1", "TRUE", "");
```

This example sets the breakpoint within a specific source file and line without using the absolute file path to the source:

```
__setCodeBreak("{main.c}.288.7", 0, "1", "TRUE", "");
```

See also

*Breakpoints*, page 125.

## \_\_setDataBreak

### Syntax

In the simulator:

```
__setDataBreak(location, count, condition, cond_type, access,  
              action)
```

In the C-SPY I-jet driver and in the C-SPY CMSIS-DAP driver:

```
__setDataBreak(location, access, extend, match, data, mask)
```

### Parameters

*location*

A string that defines the data location of the breakpoint, either a valid C-SPY expression whose value evaluates to a valid address or an absolute location. For information about the location types, see *Enter Location dialog box*, page 159.

*count*

An integer that specifies the number of times that a breakpoint condition must be fulfilled before a break occurs the next time.

This parameter only applies to the simulator.

*condition*

The breakpoint condition (string).

This parameter only applies to the simulator.

*cond\_type*

The condition type; either "CHANGED" or "TRUE" (string).

This parameter only applies to the simulator.

*access*

The memory access type: "R", for read, "W" for write, or "RW" for read/write.

*action*

An expression, typically a call to a macro, which is evaluated when the breakpoint is detected.

This parameter only applies to the simulator.

*extend*

Extends the breakpoint so that a whole data structure is covered. For data structures that do not fit the size of the possible breakpoint ranges supplied by the hardware breakpoint unit, for example three bytes, the breakpoint range will not cover the whole data structure. Note that the breakpoint range will be extended beyond the size of the data structure, which might cause false triggers at adjacent data. Choose between "TRUE" or "FALSE".

This parameter only applies to the C-SPY I-jet driver and the C-SPY CMSIS-DAP driver.

*match*

Enables matching of the accessed data. Choose between "TRUE" or "FALSE".

This parameter only applies to the C-SPY I-jet driver and the C-SPY CMSIS-DAP driver.

*data*

A data value to match, in unsigned 32-bit format.

This parameter only applies to the C-SPY I-jet driver and the C-SPY CMSIS-DAP driver.

*mask*

Specifies which part of the data value to match—word, halfword, or byte—in unsigned 32-bit format.

This parameter only applies to the C-SPY I-jet driver and the C-SPY CMSIS-DAP driver.

## Return value

Result	Value
Successful	An unsigned integer uniquely identifying the breakpoint. This value must be used to clear the breakpoint.
Unsuccessful	0

Table 42: `__setDataBreak` return values

## For use with

The C-SPY simulator.  
 The C-SPY CMSIS-DAP driver.  
 The C-SPY GDB Server driver.  
 The C-SPY G+LINK driver.  
 The C-SPY I-jet driver.  
 The C-SPY J-Link driver.

	The C-SPY PE micro driver.
	The C-SPY ST-Link driver.
	The C-SPY TI MSP-FET driver.
	The C-SPY TI Stellaris driver.
	The C-SPY TI XDS driver.
Description	Sets a data breakpoint, that is, a breakpoint which is triggered directly after the processor has read or written data at the specified location.
Example	<p>For the C-SPY simulator:</p> <pre>__var brk; brk = __setDataBreak("Memory:0x4710", 3, "d&gt;6", "TRUE",     "W", "ActionData()"); ... __clearBreak(brk);</pre> <p>For I-jet:</p> <pre>__var brk; brk = __setDataBreak("myVar", "W", "FALSE", "TRUE",     0xABCD, 0xFFFF); ... __clearBreak(brk);</pre>
See also	<i>Breakpoints</i> , page 125.

## **\_\_setDataLogBreak**

Syntax	<code>__setDataLogBreak(<i>variable</i>, <i>access</i>, <i>extend</i>)</code>
Parameters	<p><i>variable</i></p> <p>A string that defines the variable the breakpoint is set on, a variable of integer type with static storage duration. The microcontroller must also be able to access the variable with a single-instruction memory access, which means that you can only set data log breakpoints on 8, 16, and 32-bit variables.</p> <p><i>access</i></p> <p>The memory access type: "R", for read, "W" for write, or "RW" for read/write.</p> <p><i>extend</i></p> <p>Use extended range: "TRUE" or "FALSE".</p>

This parameter is only available when using a device and a debug probe that support SWO.

## Return value

Result	Value
Successful	An unsigned integer uniquely identifying the breakpoint. This value must be used to clear the breakpoint.
Unsuccessful	0

Table 43: `__setDataLogBreak` return values

## For use with

The C-SPY simulator. (Not available for all cores and devices.)  
A device and a debug probe with support for SWO.

## Description

Sets a data log breakpoint, that is, a breakpoint which is triggered when a specified variable is accessed. Note that a data log breakpoint does not stop the execution, it just generates a data log.

## Example

For the simulator:

```
__var brk;
brk = __setDataLogBreak("MyVar", "R");
...
__clearBreak(brk);
```

For the C-SPY I-jet driver:

```
__var brk;
brk = __seDataLogBreak("myVar", "RW", "FALSE");
...
__clearBreak(brk);
```

## See also

*Breakpoints*, page 125 and *Getting started using data logging*, page 262.

## `__setLogBreak`

## Syntax

```
__setLogBreak(location, message, msg_type, condition,
              cond_type)
```

## Parameters

*location*

A string that defines the code location of the breakpoint, either a valid C-SPY expression whose value evaluates to a valid address, an absolute location, or a source location. For more information about the location types, see *Enter Location dialog box*, page 159.

*message*

The message text.

*msg\_type*

The message type; choose between:

TEXT, the message is written word for word.

ARGS, the message is interpreted as a comma-separated list of C-SPY expressions or strings.

*condition*

The breakpoint condition (string).

*cond\_type*

The condition type; either "CHANGED" or "TRUE" (string).

Return value

Result	Value
Successful	An unsigned integer uniquely identifying the breakpoint. The same value must be used when you want to clear the breakpoint.
Unsuccessful	0

Table 44: `__setLogBreak` return values

For use with

All C-SPY drivers.

Description

Sets a log breakpoint, that is, a breakpoint which is triggered when an instruction is fetched from the specified location. If you have set the breakpoint on a specific machine instruction, the breakpoint will be triggered and the execution will temporarily halt and print the specified message in the C-SPY **Debug Log** window.

## Example

```

__var logBp1;
__var logBp2;

logOn()
{
    logBp1 = __setLogBreak ("{C:\\temp\\Utilities.c}.23.1",
        "\"Entering trace zone at :\", #PC:%X", "ARGS", "1", "TRUE");
    logBp2 = __setLogBreak ("{C:\\temp\\Utilities.c}.30.1",
        "Leaving trace zone...", "TEXT", "1", "TRUE");
}

logOff()
{
    __clearBreak(logBp1);
    __clearBreak(logBp2);
}

```

## See also

*Formatted output*, page 438 and *Breakpoints*, page 125.

**\_\_setSimBreak**

## Syntax

```
__setSimBreak(location, access, action)
```

## Parameters

*location*

A string that defines the data location of the breakpoint, either a valid C-SPY expression whose value evaluates to a valid address or an absolute location. For information about the location types, see *Enter Location dialog box*, page 159.

*access*

The memory access type: "R" for read or "W" for write.

*action*

An expression, typically a call to a macro, which is evaluated when the breakpoint is detected.

## Return value

Result	Value
Successful	An unsigned integer uniquely identifying the breakpoint. This value must be used to clear the breakpoint.
Unsuccessful	0

Table 45: *\_\_setSimBreak* return values

## For use with

The C-SPY simulator. (Not available for all cores and devices.)



## Description

Use this system macro to set *immediate* breakpoints, which will halt instruction execution only temporarily. This allows a C-SPY macro function to be called when the processor is about to read data from a location or immediately after it has written data. Instruction execution will resume after the action.

This type of breakpoint is useful for simulating memory-mapped devices of various kinds (for instance serial ports and timers). When the processor reads at a memory-mapped location, a C-SPY macro function can intervene and supply the appropriate data. Conversely, when the processor writes to a memory-mapped location, a C-SPY macro function can act on the value that was written.

**\_\_setTraceStartBreak**

## Syntax

In the simulator:

```
__setTraceStartBreak(location)
```

In the I-jet driver:

```
__setTraceStartBreak(location, access, extend, match, data, mask)
```

## Parameters

*location*

A string that defines the code location of the breakpoint, either a valid C-SPY expression whose value evaluates to a valid address, an absolute location, or a source location. For more information about the location types, see *Enter Location dialog box*, page 159.

*access*

The memory access type—"F" for fetch, "R" for read, "W" for write, or "RW" for read/write.

This parameter only applies to I-jet.

*extend*

Extends the breakpoint so that a whole data structure is covered. For data structures that do not fit the size of the possible breakpoint ranges supplied by the hardware breakpoint unit, for example three bytes, the breakpoint range will not cover the whole data structure. Note that the breakpoint range will be extended beyond the size of the data structure, which might cause false triggers at adjacent data. Choose between "TRUE" or "FALSE".

This parameter only applies to I-jet.

*match*

Enables matching of the accessed data. Choose between "TRUE" or "FALSE".

This parameter only applies to I-jet.

*data*

A data value to match, in unsigned 32-bit format.

This parameter only applies to I-jet.

*mask*

Specifies which part of the data value to match (word, halfword, or byte), in unsigned 32-bit format.

This parameter only applies to I-jet.

Return value

Result	Value
Successful	An unsigned integer uniquely identifying the breakpoint. The same value must be used when you want to clear the breakpoint.
Unsuccessful	0

Table 46: `__setTraceStartBreak` return values

For use with

The C-SPY simulator. (Not available for all cores and devices.)  
The C-SPY I-jet driver.

Description

Sets a breakpoint at the specified location. When that breakpoint is triggered, the trace system is started.

Example

```
__var startTraceBp;
__var stopTraceBp;

traceOn()
{
    startTraceBp = __setTraceStartBreak
        ("C:\\TEMP\\Utilities.c".23.1");
    stopTraceBp = __setTraceStopBreak
        ("C:\\temp\\Utilities.c".30.1");
}

traceOff()
{
    __clearBreak(startTraceBp);
    __clearBreak(stopTraceBp);
}
```

See also

*Trace Start Trigger breakpoint dialog box*, page 239.

## \_\_setTraceStopBreak

### Syntax

In the simulator:

```
__setTraceStopBreak(location)
```

In the I-jet driver:

```
__setTraceStopBreak(location, access, extend, match, data, mask)
```

### Parameters

*location*

A string that defines the code location of the breakpoint, either a valid C-SPY expression whose value evaluates to a valid address, an absolute location, or a source location. For more information about the location types, see *Enter Location dialog box*, page 159.

*access*

The memory access type: "F" for fetch, "R" for read, "W" for write, or "RW" for read/write.

This parameter only applies to I-jet.

*extend*

Extends the breakpoint so that a whole data structure is covered. For data structures that do not fit the size of the possible breakpoint ranges supplied by the hardware breakpoint unit, for example three bytes, the breakpoint range will not cover the whole data structure. Note that the breakpoint range will be extended beyond the size of the data structure, which might cause false triggers at adjacent data. Choose between "TRUE" or "FALSE".

This parameter only applies to I-jet.

*match*

Enables matching of the accessed data. Choose between "TRUE" or "FALSE".

This parameter only applies to I-jet.

*data*

A data value to match, in unsigned 32-bit format.

This parameter only applies to I-jet.

*mask*

Specifies which part of the data value to match (word, halfword, or byte), in unsigned 32-bit format.

This parameter only applies to I-jet.

Return value

Result	Value
Successful	An unsigned integer uniquely identifying the breakpoint. The same value must be used when you want to clear the breakpoint.
Unsuccessful	int 0

Table 47: `__setTraceStopBreak` return values

For use with

The C-SPY simulator. (Not available for all cores and devices.)  
The C-SPY I-jet driver.

Description

Sets a breakpoint at the specified location. When that breakpoint is triggered, the trace system is stopped.

Example

See `__setTraceStartBreak`, page 493.

See also

*Trace Stop Trigger breakpoint dialog box*, page 240.

## `__sourcePosition`

Syntax

```
__sourcePosition(linePtr, colPtr)
```

Parameters

*linePtr*

Pointer to the variable storing the line number

*colPtr*

Pointer to the variable storing the column number

Return value

Result	Value
Successful	Filename string
Unsuccessful	Empty (" ") string

Table 48: `__sourcePosition` return values

For use with

All C-SPY drivers.

Description

If the current execution location corresponds to a source location, this macro returns the filename as a string. It also sets the value of the variables, pointed to by the parameters, to the line and column numbers of the source location.

## \_\_strFind

Syntax	<code>__strFind(<i>macroString</i>, <i>pattern</i>, <i>position</i>)</code>
Parameters	<p><i>macroString</i> A macro string.</p> <p><i>pattern</i> The string pattern to search for</p> <p><i>position</i> The position where to start the search. The first position is 0</p>
Return value	The position where the pattern was found or -1 if the string is not found.
For use with	All C-SPY drivers.
Description	This macro searches a given string ( <i>macroString</i> ) for the occurrence of another string ( <i>pattern</i> ).
Example	<pre>__strFind("Compiler", "pile", 0) = 3 __strFind("Compiler", "foo", 0) = -1</pre>
See also	<i>Macro strings</i> , page 436.

## \_\_subString

Syntax	<code>__subString(<i>macroString</i>, <i>position</i>, <i>length</i>)</code>
Parameters	<p><i>macroString</i> A macro string.</p> <p><i>position</i> The start position of the substring. The first position is 0.</p> <p><i>length</i> The length of the substring</p>
Return value	A substring extracted from the given macro string.
For use with	All C-SPY drivers.
Description	This macro extracts a substring from another string ( <i>macroString</i> ).

Example	<code>__subString("Compiler", 0, 2)</code> The resulting macro string contains Co. <code>__subString("Compiler", 3, 4)</code> The resulting macro string contains pile.
See also	<i>Macro strings</i> , page 436.

## **\_\_systeml**

Syntax	<code>__systeml(<i>string</i>)</code>
Parameters	<i>string</i> The command line used to start an external application. In some cases, the full path is needed. If it contains space characters, quotation marks escaped with backslashes (\") can be added to encapsulate the path, and, separately, the arguments to the application, like this: <code>"\"D:\My projects\my app\app.exe\" \"some argument\""</code> .
Return value	The exit code returned from the external application. If the application could not be launched or fails to return an appropriate exit code, 1 is returned.
For use with	All C-SPY drivers.
Description	This macro launches an external application. It ignores all output returned from the application. Terminates the launched application if the application has not finished within 10 seconds.
Example	<code>__var exitCode;</code>  <code>exitCode = __systeml("mkdir tmp");</code>

## \_\_system2

Syntax	<code>__system2(<i>string</i>, &amp;<i>output</i>)</code>
Parameters	<p><i>string</i></p> <p>The command line used to start an external application. In some cases, the full path is needed. If it contains space characters, quotation marks escaped with backslashes (\ ") can be added to encapsulate the path, and, separately, the arguments to the application, like this:</p> <pre>"\"D:\\My projects\\my app\\app.exe\" \"some argument\""</pre> <p><i>output</i></p> <p>The output returned from the application. Both the <code>stdout</code> and the <code>stderr</code> streams are stored in this variable.</p>
Return value	The exit code returned from the external application. If the application could not be launched or fails to return an appropriate exit code, 1 is returned.
For use with	All C-SPY drivers.
Description	This macro launches an external application. The output from both the <code>stdout</code> and the <code>stderr</code> streams is stored in <i>output</i> . If no data has been received from the launched application within 10 seconds, or when the returned data exceeds 65535 bytes, the application is terminated. This restriction prevents the Embedded Workbench IDE from freezing or crashing because of misbehaving applications.
Example	<pre>__var exitCode; __var out_err;  exitCode = __system2("dir /S", &amp;out_err);  __message "Output from the dir command:"; __message out_err;</pre>

## \_\_system3

Syntax	<code>__system3(<i>string</i>, &amp;<i>output</i>, &amp;<i>error</i>)</code>
Parameters	<p><i>string</i></p> <p>The command line used to start an external application. In some cases, the full path is needed. If it contains space characters, quotation marks escaped with backslashes (\ ") can be added to encapsulate the path, and, separately, the arguments to the application, like this:</p> <pre>"\"D:\\My projects\\my app\\app.exe\" \"some argument\""</pre> <p><i>output</i></p> <p>The output returned from the <code>stdout</code> output stream of the application.</p> <p><i>error</i></p> <p>The output returned from the <code>stderr</code> output stream of the application.</p>
Return value	The exit code returned from the external application. If the application could not be launched or fails to return an appropriate exit code, 1 is returned.
For use with	All C-SPY drivers.
Description	This macro launches an external application. The output from the <code>stdout</code> stream is stored in <i>output</i> and the <code>stderr</code> stream is stored in <i>error</i> . If no data has been received from the launched application within 10 seconds, or when the returned data exceeds 65535 bytes, the application is terminated. This restriction prevents the Embedded Workbench IDE from freezing or crashing because of misbehaving applications.
Example	<pre>__var exitCode; __var out; __var err;  exitCode = __system3("dir /S", &amp;out, &amp;err);  __message "Output from the dir command:"; __message out;  __message "Error text from the dir command:"; __message err;</pre>

## \_\_targetDebuggerVersion

Syntax	<code>__targetDebuggerVersion()</code>
--------	--



Return value	A string that represents the version number of the C-SPY debugger processor module.
For use with	All C-SPY drivers.
Description	This macro returns the version number of the C-SPY debugger processor module.
Example	<pre>__var toolVer; toolVer = __targetDebuggerVersion(); __message "The target debugger version is, ", toolVer;</pre>

## **\_\_toLower**

Syntax	<code>__toLower(<i>macroString</i>)</code>
Parameters	<p><i>macroString</i></p> <p>A macro string.</p>
Return value	The converted macro string.
For use with	All C-SPY drivers.
Description	This macro returns a copy of the parameter <i>macroString</i> where all the characters have been converted to lower case.
Example	<pre>__toLower("IAR")</pre> <p>The resulting macro string contains <i>iar</i>.</p> <pre>__toLower("Mix42")</pre> <p>The resulting macro string contains <i>mix42</i>.</p>
See also	<i>Macro strings</i> , page 436.

## **\_\_toString**

Syntax	<code>__toString(<i>C_string</i>, <i>maxlength</i>)</code>
Parameters	<p><i>C_string</i></p> <p>Any null-terminated C string.</p> <p><i>maxlength</i></p> <p>The maximum length of the returned macro string.</p>

Return value	Macro string.
For use with	All C-SPY drivers.
Description	This macro is used for converting C strings ( <code>char*</code> or <code>char[]</code> ) into macro strings.
Example	Assuming your application contains this definition: <pre>char const * hptr = "Hello World!";</pre> this macro call: <pre>__toString(hptr, 5)</pre> would return the macro string containing Hello.
See also	<i>Macro strings</i> , page 436.

## **\_\_toUpper**

Syntax	<code>__toUpper(<i>macroString</i>)</code>
Parameters	<i>macroString</i> A macro string.
Return value	The converted string.
For use with	All C-SPY drivers.
Description	This macro returns a copy of the parameter <i>macroString</i> where all the characters have been converted to upper case.
Example	<pre>__toUpper("string")</pre> The resulting macro string contains <code>STRING</code> .
See also	<i>Macro strings</i> , page 436.

## **\_\_unloadImage**

Syntax	<code>__unloadImage(<i>module_id</i>)</code>
--------	--

**Parameters** `module_id`  
An integer which represents a unique module identification, which is retrieved as a return value from the corresponding `__loadImage` C-SPY macro.

**Return value**

Value	Result
<code>module_id</code>	A unique module identification (the same as the input parameter).
<code>int 0</code>	The unloading failed.

Table 49: `__unloadImage` return values

**For use with** All C-SPY drivers.

**Description** Unloads debug information from an already downloaded debug image.

**See also** *Loading multiple debug images*, page 59 and *Images*, page 587.

## `__wallTime_ms`

**Syntax** `__wallTime_ms()`

**Return value** Returns the current host computer CPU time in milliseconds.

**For use with** All C-SPY drivers.

**Description** This macro returns the current host computer CPU time in milliseconds. The first call will always return 0.

**Example**

```
__var t1;
__var t2;

t1 = __wallTime_ms();
__var i;
for (i =0; i < 1000; i++)
    __message "Tick";
t2 = __wallTime_ms();
__message "Elapsed time: ", t2 - t1;
```

## `__whichCore`

**Syntax** `__whichCore()`

**Return value** Returns the currently running core. The cores are numbered from 0 and upwards.

**For use with** All C-SPY drivers.

**Description** When used in target execution, for example in a breakpoint condition or action, this macro returns the number of the core currently executing the application. Note that using this macro outside target execution will return -1.

**Example**

```
logAndMaybeStop()
{
    __var core;
    core = __whichCore();
    __message "Breakpoint hit by core ", core;
    return core == 2;
}
```

When used as a breakpoint condition, the function will log every hit but stop only when it hits core 2.

## \_\_writeAPReg

**Syntax** `__writeAPReg(data, register)`

**Parameters**

<i>data</i>	A 32-bit value.
<i>register</i>	An 8-bit AP register offset.

**Return value**

Result	Value
Successful	true
Unsuccessful	false

Table 50: \_\_writeAPReg return values

**For use with** The C-SPY I-Jet driver.  
The C-SPY J-Link/J-Trace driver.  
The C-SPY TI Stellaris driver.

**Description** Performs a write operation to an AP register of the currently selected access port.

## \_\_writeDPReg

Syntax

```
__writeDPReg(data, register)
```

Parameters

<i>data</i>	A 32-bit value.
<i>register</i>	An 8-bit DP register offset.

Return value

Result	Value
Successful	true
Unsuccessful	false

Table 51: \_\_writeDPReg return values

For use with

The C-SPY I-Jet driver.  
 The C-SPY J-Link/J-Trace driver.  
 The C-SPY TI Stellaris driver.

Description

Performs a write operation to a DP register.

Example

```
__writeDPReg(0x010000F0, 0x8)
/* Selects access port 1 and bank 15 */
```

## \_\_writeFile

Syntax

```
__writeFile(fileHandle, value)
```

Parameters

<i>fileHandle</i>	A macro variable used as filehandle by the __openFile macro.
<i>value</i>	An integer.

Return value

```
int 0
```

For use with

All C-SPY drivers.

Description

Prints the integer value in hexadecimal format (with a trailing space) to the file *file*.

**Note:** The \_\_fmessage statement can do the same thing. The \_\_writeFile macro is provided for symmetry with \_\_readFile.

**\_\_writeFileByte**

Syntax	<code>__writeFileByte(<i>fileHandle</i>, <i>value</i>)</code>
Parameters	<p><i>fileHandle</i></p> <p>A macro variable used as filehandle by the <code>__openFile</code> macro.</p> <p><i>value</i></p> <p>An integer.</p>
Return value	<code>int 0</code>
For use with	All C-SPY drivers.
Description	Writes one byte to the file <i>fileHandle</i> .

**\_\_writeMemory8, \_\_writeMemoryByte**

Syntax	<code>__writeMemory8(<i>value</i>, <i>address</i>, <i>zone</i>)</code> <code>__writeMemoryByte(<i>value</i>, <i>address</i>, <i>zone</i>)</code>
Parameters	<p><i>value</i></p> <p>An integer.</p> <p><i>address</i></p> <p>The memory address (integer).</p> <p><i>zone</i></p> <p>A string that specifies the memory zone, see <i>C-SPY memory zones</i>, page 165.</p>
Return value	<code>int 0</code>
For use with	All C-SPY drivers.
Description	Writes one byte to a given memory location.
Example	<code>__writeMemory8(0x2F, 0x8020, "Memory");</code>

**\_\_writeMemory16**

Syntax	<code>__writeMemory16(<i>value</i>, <i>address</i>, <i>zone</i>)</code>
--------	---

Parameters	<p><i>value</i> An integer.</p> <p><i>address</i> The memory address (integer).</p> <p><i>zone</i> A string that specifies the memory zone, see <i>C-SPY memory zones</i>, page 165.</p>
Return value	int 0
For use with	All C-SPY drivers.
Description	Writes two bytes to a given memory location.
Example	<code>__writeMemory16(0x2FFF, 0x8020, "Memory");</code>

## **\_\_writeMemory32**

Syntax	<code>__writeMemory32(value, address, zone)</code>
Parameters	<p><i>value</i> An integer.</p> <p><i>address</i> The memory address (integer).</p> <p><i>zone</i> A string that specifies the memory zone, see <i>C-SPY memory zones</i>, page 165.</p>
Return value	int 0
For use with	All C-SPY drivers.
Description	Writes four bytes to a given memory location.
Example	<code>__writeMemory32(0x5555FFFF, 0x8020, "Memory");</code>

**\_\_writeMemory64**

Syntax	<code>__writeMemory64(value, address, zone)</code>
Parameters	<p><i>value</i> An integer.</p> <p><i>address</i> The memory address (integer).</p> <p><i>zone</i> A string that specifies the memory zone, see <i>C-SPY memory zones</i>, page 165.</p>
Return value	<code>int 0</code>
For use with	All C-SPY drivers.
Description	Writes eight bytes to a given memory location.
Example	<code>__writeMemory64(0xFFFF'FFFF'8000'0000, 0xFFFF'8000, "Memory");</code>

---

**Graphical environment for macros**

Reference information about:

- *Macro Registration window*, page 509
- *Debugger Macros window*, page 511
- *Macro Quicklaunch window*, page 513



## Macro Registration window

The **Macro Registration** window is available from the **View>Macros** submenu during a debug session.

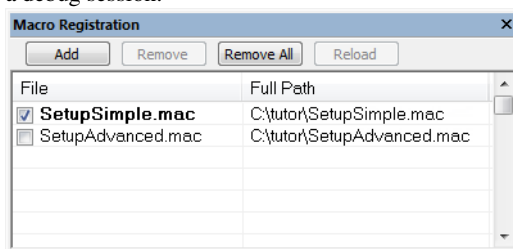

Use this window to list, register, and edit your debugger macro files.

Double-click a macro file to open it in the editor window and edit it.

See also *Registering C-SPY macros—an overview*, page 430.

### Requirements

Can be used with all C-SPY debugger drivers and debug probes.

### Display area

This area contains these columns:

#### File

The name of an available macro file. To register the macro file, select the check box to the left of the filename. The name of a registered macro file appears in bold style.

#### Full path

The path to the location of the added macro file.

## Context menu

This context menu is available:

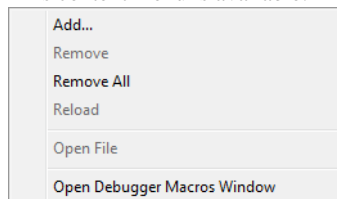

These commands are available:

### Add

Opens a file browser where you can locate the macro file that you want to add to the list. This menu command is also available as a function button at the top of the window.

### Remove

Removes the selected debugger macro file from the list. This menu command is also available as a function button at the top of the window.

### Remove All

Removes all macro files from the list. This menu command is also available as a function button at the top of the window.

### Reload

Registers the selected macro file. Typically, this is useful when you have edited a macro file. This menu command is also available as a function button at the top of the window.

### Open File

Opens the selected macro file in the editor window.

### Open Debugger Macros Window

Opens the **Debugger Macros** window.

## Debugger Macros window

The **Debugger Macros** window is available from the **View>Macros** submenu during a debug session.

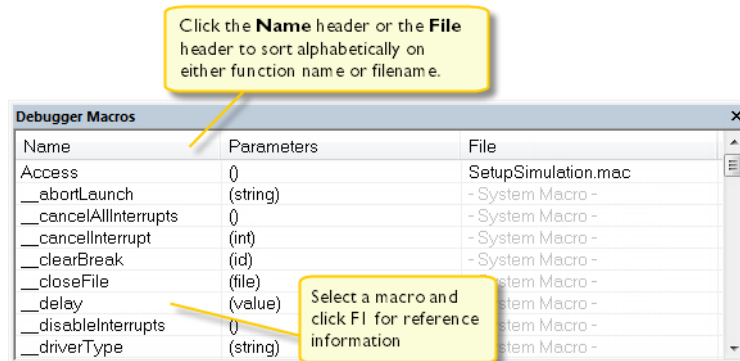

Use this window to list all registered debugger macro functions, either predefined system macros or your own. This window is useful when you edit your own macro functions and want an overview of all available macros that you can use.

- Click the column headers **Name** or **File** to sort alphabetically on either function name or filename.
- Double-clicking a macro defined in a file opens that file in the editor window.
- To open a macro in the **Macro Quicklaunch** window, drag it from the **Debugger Macros** window and drop it in the **Macro Quicklaunch** window.
- Select a macro and press F1 to get online help information for that macro.

### Requirements

Can be used with all C-SPY debugger drivers and debug probes.

### Display area

This area contains these columns:

#### Name

The name of the debugger macro.

#### Parameters

The parameters of the debugger macro.

#### File

For macros defined in a file, the name of the file is displayed. For predefined system macros, `-System Macro-` is displayed.

## Context menu

This context menu is available:

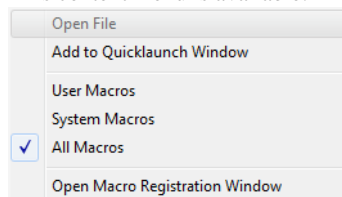

These commands are available:

### Open File

Opens the selected debugger macro file in the editor window.

### Add to Quicklaunch Window

Adds the selected macro to the **Macro Quicklaunch** window.

### User Macros

Lists only the debugger macros that you have defined yourself.

### System Macros

Lists only the predefined system macros.

### All Macros

Lists all debugger macros, both predefined system macros and your own.

### Open Macro Registration Window

Opens the **Macro Registration** window.

## Macro Quicklaunch window

The **Macro Quicklaunch** window is available from the **View** menu.

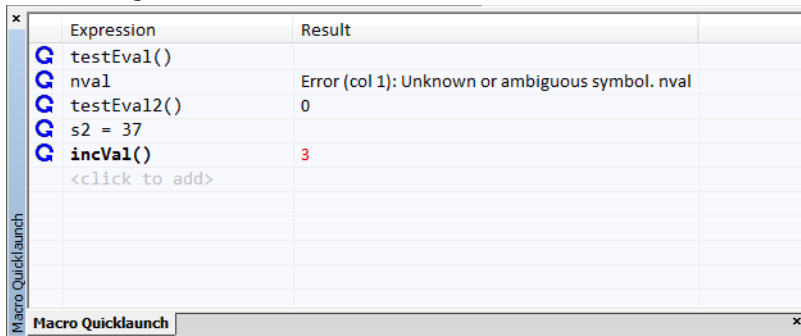

Use this window to evaluate expressions, typically C-SPY macros.

For some devices, there are predefined C-SPY macros available with device support, typically provided by the chip manufacturer. These macros are useful for performing certain device-specific tasks. The macros are available in the **Macro Quicklaunch** window and are easily identified by their green icon.

The **Macro Quicklaunch** window is similar to the **Quick Watch** window, but is primarily designed for evaluating C-SPY macros. The window gives you precise control over when to evaluate an expression.

See also *Executing C-SPY macros—an overview*, page 430.

### To add an expression:

- I Choose one of these alternatives:
  - Drag the expression to the window
  - In the **Expression** column, type the expression you want to examine.

If the expression you add and want to evaluate is a C-SPY macro, the macro must first be registered, see *Registering C-SPY macros—an overview*, page 430.

### To evaluate an expression:

- I  Double-click the **Recalculate** icon to calculate the value of that expression.

### Requirements

Can be used with all C-SPY debugger drivers and debug probes.

## Display area

This area contains these columns:



### Recalculate icon

To evaluate the expression, double-click the icon. The latest evaluated expression appears in bold style.

### Expression

One or several expressions that you want to evaluate. Click <click to add> to add an expression. If the return value has changed since last time, the value will be displayed in red.

### Result

Shows the return value from the expression evaluation.

## Context menu

This context menu is available:

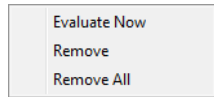

These commands are available:

### Evaluate Now

Evaluates the selected expression.

### Remove

Removes the selected expression.

### Remove All

Removes all selected expressions.

# The C-SPY command line utility—`cspybat`

- Using C-SPY in batch mode
- Summary of C-SPY command line options
- Reference information on C-SPY command line options

---

## Using C-SPY in batch mode

You can execute C-SPY in batch mode if you use the command line utility `cspybat`, installed in the directory `common\bin`.

These topics are covered:

- Starting `cspybat`
- Output
- Invocation syntax

### STARTING CSPYBAT

- 1 To start `cspybat` you must first create a batch file. An easy way to do that is to use one of the batch files that C-SPY automatically generates when you start C-SPY in the IDE.

C-SPY generates a batch file `projectname.buildconfiguration.cspy.bat` every time C-SPY is initialized. In addition, two more files are generated:

- `project.buildconfiguration.general.xml`, which contains options specific to `cspybat`
- `project.buildconfiguration.driver.xml`, which contains options specific to the C-SPY driver you are using

You can find the files in the directory `$PROJ_DIR$\settings`. The files contain the same settings as the IDE, and provide hints about additional options that you can use.

- 2 To start `cspybat`, you can use this command line:

```
project.cspybat.bat [debugfile]
```

Note that *debugfile* is optional. You can specify it if you want to use a different debug file than the one that is used in the *project.buildconfiguration.general.xcl* file.

## OUTPUT

When you run `cspybat`, these types of output can be produced:

- *Terminal output from cspybat itself*  
All such terminal output is directed to `stderr`. Note that if you run `cspybat` from the command line without any arguments, the `cspybat` version number and all available options including brief descriptions are directed to `stdout` and displayed on your screen.
- *Terminal output from the application you are debugging*  
All such terminal output is directed to `stdout`, provided that you have used the `--plugin` option. See *--plugin*, page 565.
- *Error return codes*  
`cspybat` returns status information to the host operating system that can be tested in a batch file. For *successful*, the value `int 0` is returned, and for *unsuccessful* the value `int 1` is returned.

## INVOCATION SYNTAX

The invocation syntax for `cspybat` is:

```
cspybat processor_DLL driver_DLL debug_file
        [cspybat_options] --backend driver_options
```

**Note:** In those cases where a filename is required—including the DLL files—you are recommended to give a full path to the filename.

## Parameters

The parameters are:

Parameter	Description
<i>processor_DLL</i>	The processor-specific DLL file—available in <code>arm\bin</code> .
<i>driver_DLL</i>	The C-SPY driver DLL file—available in <code>arm\bin</code> .
<i>debug_file</i>	The object file that you want to debug (filename extension <code>out</code> ). See also <i>-debug_file</i> , page 531.

Table 52: *cspybat* parameters



Parameter	Description
<i>csybat_options</i>	The command line options that you want to pass to <code>csybat</code> . Note that these options are optional. For information about each option, see <i>Reference information on C-SPY command line options</i> , page 527.
<code>--backend</code>	Marks the beginning of the parameters to the C-SPY driver; all options that follow will be sent to the driver. Note that this option is mandatory.
<i>driver_options</i>	The command line options that you want to pass to the C-SPY driver. Note that some of these options are mandatory and some are optional. For information about each option, see <i>Reference information on C-SPY command line options</i> , page 527.

Table 52: *csybat* parameters (Continued)

## Summary of C-SPY command line options

Reference information about:

- General `csybat` options
- Options available for all C-SPY drivers
- Options available for the simulator driver
- Options available for the C-SPY GDB Server driver
- Options available for the C-SPY I-jet driver
- Options available for the C-SPY CMSIS-DAP driver
- Options available for the C-SPY J-Link/J-Trace driver
- Options available for the C-SPY TI MSP-FET driver
- Options available for the C-SPY TI Stellaris driver
- Options available for the C-SPY TI XDS driver
- Options available for the C-SPY ST-LINK driver
- Options available for the C-SPY third-party drivers

### GENERAL CSPYBAT OPTIONS

<code>--application_args</code>	Passes command line arguments to the debugged application.
---------------------------------	--

<code>--attach_to_running_target</code>	Makes the debugger attach to a running application at its current location, without resetting the target system.
<code>--backend</code>	Marks the beginning of the parameters to be sent to the C-SPY driver (mandatory).
<code>--code_coverage_file</code>	Enables the generation of code coverage information and places it in a specified file.
<code>--cycles</code>	Specifies the maximum number of cycles to run.
<code>--debug_file</code>	Specifies an alternative debug file.
<code>--device_macro</code>	Specifies a C-SPY device macro file.
<code>--download_only</code>	Downloads a code image without starting a debug session afterwards.
<code>-f</code>	Extends the command line.
<code>--flash_loader</code>	Specifies a flash loader specification XML file.
<code>--macro</code>	Specifies a macro file to be used.
<code>--macro_param</code>	Assigns a value to a C-SPY macro parameter.
<code>--plugin</code>	Specifies a plugin file to be used.
<code>--rtc_enable</code>	Enables C-RUN runtime error checking in <code>cspybat</code> .
<code>--rtc_output</code>	Specifies to <code>cspybat</code> a file for the C-RUN message output.
<code>--rtc_raw_to_txt</code>	Makes <code>cspybat</code> act as a runtime checking message filter by reading a file as input.
<code>--rtc_rules</code>	Specifies a file for the C-RUN rules to <code>cspybat</code> .
<code>--silent</code>	Omits the sign-on message.
<code>--sockets</code>	Makes the debugger use sockets instead of pipes for its internal communication.
<code>--suppress_entrypoint_warning</code>	Disables the warning when the ELF entry point is at address <code>0x0</code> .
<code>--timeout</code>	Limits the maximum allowed execution time.

## OPTIONS AVAILABLE FOR ALL C-SPY DRIVERS

--BE8	Uses the big-endian format BE8. For reference information, see the <i>IAR C/C++ Development Guide for Arm</i> .
--BE32	Uses the big-endian format BE32. For reference information, see the <i>IAR C/C++ Development Guide for Arm</i> .
--cpu	Specifies a processor variant. For reference information, see the <i>IAR C/C++ Development Guide for Arm</i> .
--device	Specifies the name of the device.
--drv_communication	Specifies the communication link to be used.
--drv_communication_log	Creates a log file.
--drv_exclude_from_verify	Excludes memory ranges from being verified.
--drv_reset_to_cpu_start	Omits setting the PC when resetting the application.
--drv_debugger_cache	Disables memory caching and memory range checking in C-SPY.
--drv_restore_breakpoints	Restores automatically any breakpoints that were destroyed during system startup.
--drv_suppress_download	Suppresses download of the executable image. For reference information, see <i>Download</i> , page 586, specifically the option <b>Suppress download</b> .
--drv_vector_table_base	Specifies the location of the Cortex-M reset vector and the initial stack pointer value.
--drv_verify_download	Verifies the target program. For reference information, see <i>Download</i> , page 586, specifically the option <b>Verify download</b> .
	Available for all hardware drivers.
--endian	Specifies the byte order of the generated code and data. For reference information, see the <i>IAR C/C++ Development Guide for Arm</i> .

<code>--fpu</code>	Selects the type of floating-point unit. For reference information, see the <i>IAR C/C++ Development Guide for Arm</i> .
<code>--leave_target_running</code>	Starts the execution on the target and then exits but leaves the target running.
<code>-p</code>	Specifies the device description file to be used.
<code>--proc_stack_stack</code>	Provides C-SPY with information about reserved stacks.
<code>--semihosting</code>	Enables semihosted I/O.

### OPTIONS AVAILABLE FOR THE SIMULATOR DRIVER

<code>--disable_interrupts</code>	Disables the interrupt simulation. (Not available for all cores and devices.)
<code>--function_profiling</code>	Analyzes your source code to find where the most time is spent during execution. (Not available for all cores and devices.)
<code>--mapu</code>	Activates memory access checking. (Not available for all cores and devices.)
<code>--multicore_nr_of_cores</code>	Specify the number of cores on the device for multicore debugging. (Not available for all cores and devices.)

### OPTIONS AVAILABLE FOR THE C-SPY GDB SERVER DRIVER

<code>--drv_default_breakpoint</code>	Sets the type of breakpoint resource to be used when setting breakpoints.
<code>--drv_enforce_mem_config</code>	Prevents the driver from accessing any memory ranges in the <code>zone Memory</code> that have not been defined in the <b>Memory Configuration</b> dialog box.
<code>--gdbserv_exec_command</code>	Sends a command string to the GDB Server.

## OPTIONS AVAILABLE FOR THE C-SPY I-JET DRIVER

<code>--debug_auth_enforce</code>	Specifies that the authentication procedure should be executed when automatic detection fails.
<code>--debug_auth_settings</code>	Specifies the XML file that stores parameters required for the authentication.
<code>--debug_auth_type</code>	Specifies the mechanism used for the debug authentication.
<code>--drv_catch_exceptions</code>	Makes the application stop for certain exceptions.
<code>--drv_default_breakpoint</code>	Sets the type of breakpoint resource to be used when setting breakpoints.
<code>--drv_enforce_mem_config</code>	Prevents the driver from accessing any memory ranges in the <code>zone Memory</code> that have not been defined in the <b>Memory Configuration</b> dialog box.
<code>--drv_interface</code>	Selects the communication interface.
<code>--drv_interface_speed</code>	Specifies the JTAG and SWD interface speed.
<code>--drv_mem_ap</code>	Enables Live Watch and Live Memory reads for Cortex-A and Cortex-R devices.
<code>--drv_trace_settings</code>	Specifies the mechanism and interface for trace data collection.
<code>--jet_board_cfg</code>	Specifies a probe configuration file.
<code>--jet_board_did</code>	Selects which CPU to debug on a multicore system.
<code>--jet_cpu_clock</code>	Specifies the frequency of the internal processor clock.
<code>--jet_disable_pmu</code>	Disables the PMU event counting.
<code>--jet_disable_pmu_dap</code>	Disables the PMU DAP channel and uses CP15 instructions for PMU event counting.
<code>--jet_ir_length</code>	Specifies the number of IR bits preceding the Arm core to connect to.

<code>--jet_power_from_probe</code>	Specifies the power supply from the I-jet or I-jet Trace probe.
<code>--jet_probe</code>	Specifies which debug system the C-SPY I-jet driver is an interface to.
<code>--jet_script_file</code>	Specifies the reset script file.
<code>--jet_standard_reset</code>	Selects the reset strategy to be used when C-SPY starts.
<code>--jet_startup_connection_timeout</code>	Prolongs the time that the C-SPY driver tries to connect to the target board.
<code>--jet_swo_on_d0</code>	Specifies that SWO trace data is output on the trace data pin D0.
<code>--jet_swo_prescaler</code>	Specifies the SWO prescaler for the CPU clock frequency.
<code>--jet_swo_protocol</code>	Selects the SWO communication protocol.
<code>--jet_tap_position</code>	Selects a specific device in the JTAG scan chain.
<code>--reset_style</code>	Specifies the reset strategies that will be available when debugging.
<code>--sdm_debug_architecture</code>	Specifies the debug architecture used for SDM debug authentication
<code>--sdm_library</code>	Specifies the library file used for SDM debug authentication.
<code>--sdm_library_hint</code>	Specifies an alternate authentication method if the SDM library does not use the standard SDM API.
<code>--sdm_manifest</code>	Specifies a manifest file that points out the SDM debug authentication library file.

### OPTIONS AVAILABLE FOR THE C-SPY CMSIS-DAP DRIVER

<code>--debug_auth_enforce</code>	Specifies that the authentication procedure should be executed when automatic detection fails.
<code>--debug_auth_settings</code>	Specifies the XML file that stores parameters required for the authentication.

<code>--debug_auth_type</code>	Specifies the mechanism used for the debug authentication.
<code>--drv_catch_exceptions</code>	Makes the application stop for certain exceptions.
<code>--drv_default_breakpoint</code>	Sets the type of breakpoint resource to be used when setting breakpoints.
<code>--drv_enforce_mem_config</code>	Prevents the driver from accessing any memory ranges in the zone Memory that have not been defined in the <b>Memory Configuration</b> dialog box.
<code>--drv_interface</code>	Selects the communication interface.
<code>--drv_interface_speed</code>	Specifies the JTAG and SWD interface speed.
<code>--jet_board_cfg</code>	Specifies a probe configuration file.
<code>--jet_board_did</code>	Selects which CPU to debug on a multicore system.
<code>--jet_probe</code>	Specifies which debug system the C-SPY driver is an interface to.
<code>--jet_script_file</code>	Specifies the reset script file.
<code>--jet_standard_reset</code>	Selects the reset strategy to be used when C-SPY starts.
<code>--jet_startup_connection_timeout</code>	Prolongs the time that the C-SPY driver tries to connect to the target board.
<code>--jet_tap_position</code>	Selects a specific device in the JTAG scan chain.
<code>--reset_style</code>	Specifies the reset strategies that will be available when debugging.
<code>--sdm_debug_architecture</code>	Specifies the debug architecture used for SDM debug authentication
<code>--sdm_library</code>	Specifies the library file used for SDM debug authentication.
<code>--sdm_library_hint</code>	Specifies an alternate authentication method if the SDM library does not use the standard SDM API.

`--sdm_manifest` Specifies a manifest file that points out the SDM debug authentication library file.

## OPTIONS AVAILABLE FOR THE C-SPY J-LINK/J-TRACE DRIVER

`--drv_catch_exceptions` Makes the application stop for certain exceptions.

`--drv_default_breakpoint` Sets the type of breakpoint resource to be used when setting breakpoints.

`--drv_enforce_mem_config` Prevents the driver from accessing any memory ranges in the zone `Memory` that have not been defined in the **Memory Configuration** dialog box.

`--drv_interface` Selects the communication interface.

`--drv_interface_speed` Specifies the JTAG and SWD interface speed.

`--drv_mem_ap` Enables Live Watch and Live Memory reads for Cortex-A and Cortex-R devices.

`--drv_swo_clock_setup` Specifies the CPU clock and the wanted SWO speed.

`--jlink_dcc_timeout` Specifies the timeout for a pending request from C-SPY to the DCC agent on target.

`--jlink_device_select` Selects a specific device in the JTAG scan chain.

`--jlink_exec_command` Calls the `__jlinkExecCommand` macro after target connection has been established.

`--jlink_initial_speed` Sets the initial JTAG communication speed in kHz.

`--jlink_ir_length` Sets the number of IR bits preceding the Arm core to connect to.

`--jlink_reset_strategy` Selects the reset strategy to use at debugger startup.

`--jlink_script_file` Specifies the script file for setting up hardware.

`--jlink_trace_source` Selects either ETB or ETM as the trace source.



**OPTIONS AVAILABLE FOR THE C-SPY TI MSP-FET DRIVER**

<code>--drv_enforce_mem_config</code>	Prevents the driver from accessing any memory ranges in the zone <code>Memory</code> that have not been defined in the <b>Memory Configuration</b> dialog box.
<code>--mspfet_erase_flash</code>	Specifies which flash memory to erase before download.
<code>--mspfet_interface_speed</code>	Specifies the interface communication speed.
<code>--mspfet_reset_strategy</code>	Selects the reset strategy to use at debugger startup.
<code>--mspfet_settlingtime</code>	Specifies a delay that will be used between switching on the target VCC and starting the identification of the Arm device.
<code>--mspfet_vccvoltage</code>	Specifies the target VCC voltage.

**OPTIONS AVAILABLE FOR THE C-SPY TI STELLARIS DRIVER**

<code>--drv_enforce_mem_config</code>	Prevents the driver from accessing any memory ranges in the zone <code>Memory</code> that have not been defined in the <b>Memory Configuration</b> dialog box.
<code>--drv_interface</code>	Selects the communication interface.
<code>--drv_interface_speed</code>	Specifies the JTAG and SWD interface speed.
<code>--lmiftdi_reset_strategy</code>	Selects the reset strategy to use at debugger startup.

**OPTIONS AVAILABLE FOR THE C-SPY TI XDS DRIVER**

<code>--drv_catch_exceptions</code>	Makes the application stop for certain exceptions.
<code>--drv_default_breakpoint</code>	Sets the type of breakpoint resource to be used when setting breakpoints.

<code>--drv_enforce_mem_config</code>	Prevents the driver from accessing any memory ranges in the zone <code>Memory</code> that have not been defined in the <b>Memory Configuration</b> dialog box.
<code>--drv_interface</code>	Selects the communication interface.
<code>--drv_interface_speed</code>	Specifies the JTAG and SWD interface speed.
<code>--drv_swo_clock_setup</code>	Specifies the CPU clock and the wanted SWO speed.
<code>--xds_board_file</code>	Overrides the default board file.
<code>--xds_reset_strategy</code>	Specifies the reset strategy to use.
<code>--xds_rootdir</code>	Specifies the installation directory of the TI XDS driver package.

### OPTIONS AVAILABLE FOR THE C-SPY ST-LINK DRIVER

<code>--debug_auth_enforce</code>	Specifies that the authentication procedure should be executed when automatic detection fails.
<code>--debug_auth_settings</code>	Specifies the XML file that stores parameters required for the authentication.
<code>--debug_auth_type</code>	Specifies the mechanism used for the debug authentication.
<code>--drv_catch_exceptions</code>	Makes the application stop for certain exceptions.
<code>--drv_enforce_mem_config</code>	Prevents the driver from accessing any memory ranges in the zone <code>Memory</code> that have not been defined in the <b>Memory Configuration</b> dialog box.
<code>--drv_interface</code>	Selects the communication interface.
<code>--drv_interface_speed</code>	Specifies the JTAG and SWD interface speed.
<code>--drv_swo_clock_setup</code>	Specifies the CPU clock and the wanted SWO speed.
<code>--sdm_debug_architecture</code>	Specifies the debug architecture used for SDM debug authentication.

<code>--sdm_library</code>	Specifies the library file used for SDM debug authentication.
<code>--sdm_library_hint</code>	Specifies an alternate authentication method if the SDM library does not use the standard SDM API.
<code>--sdm_manifest</code>	Specifies a manifest file that points out the SDM debug authentication library file.
<code>--stlink_reset_strategy</code>	Specifies the reset strategy to use.

### OPTIONS AVAILABLE FOR THE C-SPY THIRD-PARTY DRIVERS

For information about any options specific to the third-party driver you are using, see its documentation.

---

## Reference information on C-SPY command line options

This section gives detailed reference information about each `cspybat` option and each option available to the C-SPY drivers.

### **--application\_args**

Syntax	<code>--application_args="arg0 arg1 ..."</code>
Parameters	<i>arg</i> A command line argument.
For use with	<code>cspybat</code>
Description	Use this option to pass command line arguments to the debugged application. These variables must be defined in the application: <pre> /* __argc, the number of arguments in __argv. */ __no_init __root int __argc;  /* __argv, an array of pointers to the arguments (strings); must be large enough to fit the number of arguments.*/ __no_init __root const char * __argv[MAX_ARGS];  /* __argvbuf, a storage area for __argv; must be large enough to hold all command line arguments. */ __no_init __root char __argvbuf[MAX_ARG_SIZE]; </pre>

## Example

```
--application_args="--logfile log.txt --verbose"
```



This option is not available in the IDE. However, command line arguments can be passed to the debugged application from the **Project>Options>Debugger>Extra Options** page using the `/args` option, see *Extra Options*, page 591.

## --attach\_to\_running\_target

## Syntax

```
--attach_to_running_target
```

## For use with

```
cspybat
```

**Note:** This option might not be supported by the combination of C-SPY driver and device that you are using. If you are using this option with an unsupported combination, C-SPY produces a message.

## Description

Use this option to make the debugger attach to a running application at its current location, without resetting the target system.

If you have defined any breakpoints in your project, the C-SPY driver will set them during attachment. If the C-SPY driver cannot set them without stopping the target system, the breakpoints will be disabled. The option also suppresses download and the **Run to** option.



**Project>Attach to Running Target**

## --backend

## Syntax

```
--backend {driver options}
```

## Parameters

*driver options*

Any option available to the C-SPY driver you are using.

## For use with

`cspybat` (mandatory).

## Description

Use this option to send options to the C-SPY driver. All options that follow `--backend` will be passed to the C-SPY driver, and will not be processed by `cspybat` itself.



This option is not available in the IDE.

## --code\_coverage\_file

Syntax	<code>--code_coverage_file=filename</code>
	Note that this option must be placed before the <code>--backend</code> option on the command line.
Parameters	<i>filename</i> The name of the destination file for the code coverage information.
For use with	<code>cspybat</code>
Description	Use this option to enable the generation of a text-based report file for code coverage information. The code coverage information will be generated after the execution has completed and you can find it in the specified file. Because most embedded applications do not terminate, you might have to use this option in combination with <code>--timeout</code> or <code>--cycles</code> .  Note that this option requires that the C-SPY driver you are using supports code coverage. If you try to use this option with a C-SPY driver that does not support code coverage, an error message will be directed to <code>stderr</code> .
See also	<i>Code coverage</i> , page 307, <i>--cycles</i> , page 529, <i>--timeout</i> , page 572.
	 To set this option, choose <b>View&gt;Code Coverage</b> , right-click and choose <b>Save As</b> when the C-SPY debugger is running.

## --cycles

Syntax	<code>--cycles cycles</code>
	Note that this option must be placed before the <code>--backend</code> option on the command line.
Parameters	<i>cycles</i> The number of cycles to run.
For use with	<code>cspybat</code>
Description	Use this option to specify the maximum number of cycles to run. If the target program executes longer than the number of cycles specified, the target program will be aborted. Using this option requires that the C-SPY driver you are using supports a cycle counter, and that it can be sampled while executing.   This option is not available in the IDE.

**--debug\_auth\_enforce**

Syntax	<code>--debug_auth_enforce</code>
For use with	The C-SPY CMSIS-DAP driver. The C-SPY I-jet driver. The C-SPY ST-LINK driver.
Description	Use this option if, for some reason, the automatic detection mechanism fails and you want to force using the authentication procedure. This could be the case if you are using a device that is not explicitly supported yet by IAR Embedded Workbench.
See also	<i>Debug authentication</i> , page 63.



**Project>Options>Debugger>Authentication>Apply authentication if status cannot be determined**

**--debug\_auth\_settings**

Syntax	<code>--debug_auth_settings=path</code>
Parameters	<i>path</i> The path to the file where the authentication parameters are stored.
For use with	The C-SPY CMSIS-DAP driver. The C-SPY I-jet driver. The C-SPY ST-LINK driver.
Description	Use this option to specify the XML file that stores parameters required for the authentication. This file is normally the <code>.dnx</code> file for the project. In the IDE, this file is selected automatically.
See also	<i>Debug authentication</i> , page 63.



This option is not available in the IDE.

**--debug\_auth\_type**

Syntax	<code>--debug_auth_type=mechanism</code>
Parameters	<i>mechanism</i> The name of the mechanism used for the debug authentication. Currently, this parameter must be <code>sdm</code> .
For use with	The C-SPY CMSIS-DAP driver. The C-SPY I-jet driver. The C-SPY ST-LINK driver.
Description	Use this option to specify the mechanism used for the debug authentication.
See also	<i>Debug authentication</i> , page 63.



This option is not available in the IDE.

**--debug\_file**

Syntax	<code>--debug_file filename</code>
Parameters	<i>filename</i> The name of the debug file to use.
For use with	<code>cspybat</code>
Description	Use this option to make <code>cspybat</code> use the specified debug file instead of the one used in the generated <code>cpsybat.bat</code> file. This option can be placed both before and after the <code>--backend</code> option on the command line.



This option is not available in the IDE.

**--device**

Syntax	<code>--device=device_name</code>	
Parameters	<i>device_name</i>	The name of the device, for example, ADuC7030, AT91SAM7S256, LPC2378, STR912FM44, or TMS470R1B1M.
For use with	All C-SPY drivers.	
Description	Use this option to specify the name of the device.	
		To set related option, choose: <b>Project&gt;Options&gt;General Options&gt;Target&gt;Device</b>

**--device\_macro**

Syntax	<code>--device_macro filename</code>	
	Note that this option must be placed before the <code>--backend</code> option on the command line.	
Parameters	<i>filename</i>	The C-SPY device macro file to be used (filename extension <code>dmac</code> ).
For use with	<code>cspybat</code>	
Description	Use this option to specify a C-SPY device macro file to be loaded before you execute the target application. A device macro is also loaded when you run a flash loader. A device macro can include scripted reset styles that can be used by the debugger. This option can be used more than once on the command line.	
See also	<i>Briefly about using C-SPY macros</i> , page 428.	
		This option is not available in the IDE.

**--disable\_interrupts**

Syntax	<code>--disable_interrupts</code>	
For use with	The C-SPY simulator driver. (Not available for all cores and devices.)	



## Description

Use this option to disable the interrupt simulation.



To set this option, choose **Simulator>Interrupt Configuration** and deselect the **Enable interrupt simulation** command on the context menu.

## --download\_only

## Syntax

```
--download_only
```

Note that this option must be placed before the `--backend` option on the command line.

## For use with

cspybat

## Description

Use this option to download the code image without starting a debug session afterwards.



**Project>Download>Download active application**

Alternatively, to set a related option, choose:

**Project>Options>Debugger>Setup** and deselect **Run to**.

## --drv\_catch\_exceptions

## Syntax

```
--drv_catch_exceptions=value
```

## Parameters

*value*

(for Arm9, Cortex-R4, Arm11,  
and Cortex-A)

A value in the range of 0–0x1FF. Each bit specifies  
which exception to catch:

Bit 0 = Reset

Bit 1 = Undefined instruction

Bit 2 = SWI

Bit 3 = Prefetch abort

Bit 4 = Data abort

Bit 5 = Not used

Bit 6 = IRQ

Bit 7 = FIQ

Bit 8 = Other errors

	<i>value</i> (for Cortex-M)	A value in the range of 0–0x7FF. Each bit specifies which exception to catch: Bit 0 = CORERESSET - Reset Vector Bit 4 = MMERR - Memory Management Fault Bit 5 = NOCPERR - Coprocessor Access Error Bit 6 = CHKERR - Checking Error Bit 7 = STATERR - State Error Bit 8 = BUSERR - Bus Error Bit 9 = INTERR - Interrupt Service Errors Bit 10 = HARDERR - Hard Fault
For use with	The C-SPY I-jet driver. The C-SPY J-Link/J-Trace driver. The C-SPY CMSIS-DAP driver. The C-SPY ST-LINK driver. The C-SPY TI XDS driver.	
Description	Use this option to make the application stop when a certain exception occurs.	
See also	<i>Setting a breakpoint on an exception vector</i> , page 135.	
		<b>Project&gt;Options&gt;Debugger&gt;Driver&gt;Breakpoints&gt;Catch exceptions</b>

## --drv\_communication

Syntax `--drv_communication=connection`

**Parameters**

Where *connection* is one of these for the C-SPY GDB Server driver:

Via Ethernet            `TCPIP:ip_address`  
                           `TCPIP:ip_address,port`  
                           `TCPIP:hostname`  
                           `TCPIP:hostname,port`

Note that if no port is specified, port 3333 is used by default.

Where *connection* is one of these for the C-SPY J-Link/J-Trace driver:

Via USB port            `USB:#serial` where *serial* is a string of digits and letters that identifies which probe you want to connect to. The serial number can be found either printed on the probe, or obtained by connecting a single probe, and then starting the debug session. The serial number is then displayed in the **Debug Log** window. The serial number is also displayed in the **Debug Probe Selection** dialog box.

`USB:#select` forces the **Debug Probe Selection** dialog box to be displayed each time you start a debug session.

Via USB directly to the debug probe    `USB0-USB3`

When using `USB0` and if there are more than one debug probes on the USB connection, a dialog box is displayed when the debug session starts. Use the dialog box to choose which debug probe to connect to.

## Via J-Link on LAN

TCPIP:

When the colon sign is not followed by any address, host name, or serial number, the J-Link driver searches for all J-Link debug probes on the local network and displays them in a dialog box where you can choose which one to connect to (Auto detect).

TCPIP:*ip\_address*

TCPIP:*ip\_address,port*

TCPIP:*hostname*

TCPIP:*hostname,port*

TCPIP:#*serial*, connects to the J-Link with the serial number *number* on the local network

Note that if no port is specified, port 19020 is used by default.

Where *connection* is one of these for the C-SPY I-jet driver:

## Via USB port

USB:#*serial* where *serial* is a string of digits and letters that identifies which probe you want to connect to. The serial number can be found either printed on the probe, or obtained by connecting a single probe, and then starting the debug session. The serial number is then displayed in the **Debug Log** window. The serial number is also displayed in the **Debug Probe Selection** dialog box.

USB:#*select* forces the **Debug Probe Selection** dialog box to be displayed each time you start a debug session.

Where *connection* is one of these for the C-SPY ST-LINK driver, the C-SPY TI Stellaris driver, and the C-SPY TI XDS driver:

Via USB port      `USB:#serial` where *serial* is a string of digits and letters that identifies which probe you want to connect to. The serial number can be found either printed on the probe, or obtained by connecting a single probe, and then starting the debug session. The serial number is then displayed in the **Debug Log** window. The serial number is also displayed in the **Debug Probe Selection** dialog box.

`USB:#select` forces the **Debug Probe Selection** dialog box to be displayed each time you start a debug session.

`USBx` where *x* is the enumeration order (0-256) of the probe when plugged in. This is an alternative notation for when the serial number cannot be used—a solution for older probes.

However, this is an uncertain method, because the order can change the next time that you plug in the probes, or when you reboot your computer. The USB port can be obtained by plugging in all probes to be used. Then use

`--drv_communication=USB:#select` to display all connected probes in the **Debug Probe Selection** dialog box.

Where *connection* is one of these for the C-SPY TI MSP-FET driver:

Via COM port      `COMx` where *x* is the enumeration order (0-256) of the probe when plugged in. This is an uncertain method, because the order can change the next time that you plug in the probes, or when you reboot your computer.

If you do not specify the option `--drv_communication`, the debug probe is automatically selected.

For use with      The C-SPY GDB Server driver.  
                      The C-SPY J-Link/J-Trace driver.  
                      The C-SPY ST-LINK driver.  
                      The C-SPY TI MSP-FET driver.  
                      The C-SPY TI Stellaris driver.  
                      The C-SPY TI XDS driver.

Description      Use this option to choose communication link.



**Project>Options>Debugger>GDB Server>TCP/IP address or hostname [,port]**

**Project>Options>Debugger>J-Link/J-Trace>Connection>Communication**

**Project>Options>Debugger>ST-LINK>Setup**

**Project>Options>Debugger>TI MSP-FET>Setup**

**Project>Options>Debugger>TI XDS>Setup**

To set this option for the C-SPY TI Stellaris driver, use

**Project>Options>Debugger>Extra Options.**

## --drv\_communication\_log

Syntax	<code>--drv_communication_log=<i>filename</i></code>	
Parameters	<i>filename</i>	The name of the log file.
For use with	All C-SPY hardware drivers.	
Description	Use this option to log the communication between C-SPY and the target system to a file. To interpret the result, detailed knowledge of the communication protocol is required.	



**Project>Options>Debugger>Driver>Log communication**

## --drv\_debugger\_cache

Syntax	<code>--drv_debugger_cache={on off}</code>	
Parameters	<code>on</code>	Enables memory caching and memory range checking.
	<code>off</code>	Disables memory caching and memory range checking.
For use with	All C-SPY drivers.	
Description	Use this option to completely disable memory caching and memory range checking in C-SPY.	

Normally, C-SPY uses the memory range information in the **Memory Configuration** dialog box both to restrict access to certain parts of target memory and to cache target memory contents for improved C-SPY performance. Under certain rare circumstances,

this is not appropriate, and you can choose **Disable Debugger Cache** to turn off the caching and memory range checking completely. All accesses from C-SPY will then result in corresponding accesses to the target system. Some of those circumstances are:

- When memory is remapped at runtime and cannot be specified as a fixed set of ranges.
- When the memory range setup is incorrect or incomplete.



**Driver>Disable Debugger Cache**

## --drv\_default\_breakpoint

Syntax	<code>--drv_default_breakpoint={0 1 2}</code>	
Parameters	0	Auto (default)
	1	Hardware
	2	Software
For use with	<p>The C-SPY GDB Server driver.</p> <p>The C-SPY I-jet driver.</p> <p>The C-SPY J-Link/J-Trace driver.</p> <p>The C-SPY CMSIS-DAP driver.</p> <p>The C-SPY TI XDS driver.</p>	
Description	Use this option to select the type of breakpoint resource to be used when setting a breakpoint.	
See also	<i>Breakpoints options</i> , page 154.	



**Project>Options>Debugger>Driver>Breakpoints>Default breakpoint type**

**--drv\_enforce\_mem\_config**

Syntax	<code>--drv_enforce_mem_config={on off}</code>	
Parameters	<code>on</code>	Restricts which memory ranges that can be accessed.
	<code>off</code>	Allows C-SPY to access all memory ranges.
For use with	The C-SPY CMSIS-DAP driver.	
	The C-SPY GDB Server driver.	
	The C-SPY I-jet driver.	
	The C-SPY J-Link driver.	
	The C-SPY ST-Link driver.	
	The C-SPY TI Stellaris driver.	
Description	The C-SPY TI XDS driver.	
	Use this option to prevent the driver from accessing any memory ranges in the zone Memory that have not been defined in the <b>Memory Configuration</b> dialog box.	

**Driver>Enforce Memory Configuration****--drv\_exclude\_from\_verify**

Syntax	<code>--drv_exclude_from_verify=startaddr-endaddr</code>	
Parameters	<code>startaddr</code>	The start of the memory range.
	<code>endaddr</code>	The end of the memory range.
For use with	All C-SPY drivers.	
Description	Use this option to exclude memory ranges from being verified when the option <code>--drv_verify_download</code> , or the option <b>Verify download</b> in the <b>Project&gt;Options</b> dialog box in the IDE, is used. The option can be specified multiple times to exclude several ranges.	





To set this option, use **Project>Options>Debugger>Extra Options**.

## --drv\_interface

### Syntax

```
--drv_interface={SWD|JTAG|cJTAG|auto}
```

### Parameters

SWD	Specifies the SWD interface
JTAG (default)	Specifies the JTAG interface
cJTAG	Specifies the cJTAG interface.  This parameter is only available for the C-SPY I-jet driver, the J-Link/J-Trace driver, and the C-SPY TI XDS driver.
auto	Automatically selects the debug interface. This parameter is only available for the C-SPY TI MSP-FET driver.

### For use with

The C-SPY CMSIS-DAP driver.  
The C-SPY I-jet driver.  
The C-SPY J-Link/J-Trace driver.  
The C-SPY ST-LINK driver.  
The C-SPY TI MSP-FET driver.  
The C-SPY TI Stellaris driver.  
The C-SPY TI XDS driver.

### Description

Use this option to specify the communication interface between the debug probe and the target system.

The SWD interface uses fewer pins than JTAG. Specify `--drv_interface=SWD` if you want to use the serial-wire output (SWO) communication channel. Alternatively, you can set this option to `JTAG` and also specify the `--jet_swo_on_d0` option. SWO output on `Trace_D0` is only supported by the C-SPY I-Jet/I-jet Trace driver.

**Note:** If you select **stdout/stderr via SWO** on the **General Options>Library Configuration** page, SWD is selected automatically, unless the device supports output of SWO on `Trace_D0`.

### See also

- *SWO Trace Window Settings dialog box*, page 223

- *J-Link/J-Trace — Connection*, page 615
- *ST-LINK — Setup*, page 618



**Project>Options>Debugger>CMSIS-DAP>Interface>Interface**

**Project>Options>Debugger>I-jet>Interface>Interface**

**Project>Options>Debugger>J-Link/J-Trace>Connection>Interface**

**Project>Options>Debugger>ST-LINK>Setup>Interface**

**Project>Options>Debugger>TI MSP-FET>Setup>Interface**

**Project>Options>Debugger>TI Stellaris>Setup>Interface**

**Project>Options>Debugger>TI XDS>Setup>Interface**

## **--drv\_interface\_speed**

Syntax	<code>--drv_interface_speed=kHz</code>
Parameters	<code>kHz</code> The frequency in kHz
For use with	The C-SPY CMSIS-DAP driver. The C-SPY I-jet driver. The C-SPY J-Link/J-Trace driver. The C-SPY ST-LINK driver. The C-SPY TI Stellaris driver. The C-SPY TI XDS driver.
Description	Use this option to set the JTAG and SWD communication speed in kHz.
See also	<i>J-Link/J-Trace — Setup</i> , page 611.
	 <b>Project&gt;Options&gt;Debugger&gt;CMSIS-DAP&gt;Interface&gt;Interface speed</b> <b>Project&gt;Options&gt;Debugger&gt;I-jet&gt;Interface&gt;Interface speed</b> <b>Project&gt;Options&gt;Debugger&gt;J-Link/J-Trace&gt;Setup&gt;JTAG/SWD speed</b> <b>Project&gt;Options&gt;Debugger&gt;ST-LINK&gt;Setup&gt;Interface&gt;Interface speed</b> <b>Project&gt;Options&gt;Debugger&gt;TI Stellaris&gt;Setup&gt;JTAG/SWD speed</b>

**Project>Options>Debugger>TI XDS>Setup>Interface>Interface speed****--drv\_mem\_ap**

Syntax	<code>--drv_mem_ap=<i>n</i></code>	
Parameters	<i>n</i>	The number of the MEM-AP port where all Live Watch and Live Memory reads will be redirected.
For use with	The C-SPY I-jet driver. The C-SPY J-Link/J-Trace driver.	
Description	Use this option to enable Live Watch and Live Memory reads for Cortex-A and Cortex-R devices. All Live Watch and Live Memory reads will be redirected through the specified MEM-AP port. This requires the presence of a suitable MEM-AP port. <b>Note:</b> Because the memory is redirected through a MEM-AP port, the memory viewed through this port will not be the same as the memory viewed from the CPU, if the MMU translation is not one to one.	



To set this option, use **Project>Options>Debugger>Extra Options**.

**--drv\_reset\_to\_cpu\_start**

Syntax	<code>--drv_reset_to_cpu_start</code>	
For use with	The C-SPY GDB Server driver. The C-SPY J-Link/J-Trace driver. The C-SPY ST-LINK driver. The C-SPY TI Stellaris driver. The C-SPY TI XDS driver.	
Description	Normally, at reset, the debugger sets PC to the entry point of the application. This option omits setting the PC each time that the application is reset. This can be useful when you want to keep the reset value that the CPU sets at reset, for example to start executing from the first instruction pointed out by the vector table, or to run a bootloader or OS startup code before entering the start address of the application.	

This option also keeps the value of the `SP` (for Cortex-M) or `CPSR` register (for other devices) set by the CPU.



To set this option, use **Project>Options>Debugger>Extra Options**.

## --drv\_restore\_breakpoints

Syntax	<code>--drv_restore_breakpoints=<i>location</i></code>
Parameters	<i>location</i> Address or function name label
For use with	The C-SPY GDB Server driver. The C-SPY I-jet driver. The C-SPY J-Link/J-Trace driver. The C-SPY CMSIS-DAP driver. The C-SPY ST-LINK driver. The C-SPY TI XDS driver.
Description	Use this option to restore automatically any software breakpoints that were overwritten during system startup.
See also	<i>Breakpoints options</i> , page 154.



**Project>Options>Debugger>Driver>Breakpoints>Restore software breakpoints at**

## --drv\_swo\_clock\_setup

Syntax	<code>--drv_swo_clock_setup=<i>frequency, autodetect, wanted</i></code>
Parameters	<i>frequency</i> The exact clock frequency used by the internal processor clock, <code>HCLK</code> , in Hz. This value is used for configuring the SWO communication speed and for calculating timestamps.

	<i>autodetect</i>	0, Specify the wanted frequency using the parameter <i>wanted</i> .  1, Automatically uses the highest possible frequency that the J-Link debug probe can handle.
	<i>wanted</i>	The frequency to be used, if <i>autodetect</i> is 0, in Hz. Use <i>wanted</i> if data packets are lost during transmission.
For use with	The C-SPY J-Link/J-Trace driver. The C-SPY ST-LINK driver. The C-SPY TI XDS driver.	

**Description** Use this option to set up the CPU clock. If this option is not used, the CPU clock frequency is by default set to 72 MHz.



**Project>Options>Debugger>J-Link/J-Trace>Setup>Clock setup**

**Project>Options>Debugger>ST-LINK>Communication>Clock setup**

**Project>Options>Debugger>TI XDS>Communication>Clock setup**

## --drv\_trace\_settings

**Syntax** `--drv_trace_settings={Auto|ETB|ETM|SWO|None}`

### Parameters

Auto	Automatically selects the best possible mechanism and interface, depending on probe and board/device capabilities.
ETB	Collects trace data through the on-chip (ETB/MTB) interface.
ETM	Collects trace data through the parallel (ETM) interface.
SWO	Collects trace data through the serial (SWO) interface.
None	Disables trace. In this mode, C-SPY will not access any trace-related on-chip resources.

**For use with** The C-SPY I-jet driver.

**Description** Use this option to specify the mechanism and interface for trace data collection. For detailed information, see *I-jet — Trace*, page 607.



**Project>Options>Debugger>I-jet>Trace>Mode**

## **--drv\_vector\_table\_base**

**Syntax** `--drv_vector_table_base=expression`

**Parameters** *expression* A label or an address

**For use with** The C-SPY GDB Server driver.  
 The C-SPY I-jet driver.  
 The C-SPY J-Link/J-Trace driver.  
 The C-SPY CMSIS-DAP driver.  
 The C-SPY TI Stellaris driver.  
 The C-SPY TI XDS driver.  
 The C-SPY ST-LINK driver.  
 The C-SPY Simulator driver.

**Description** Use this option to specify the location of the reset vector (this also determines the placement of the initial stack pointer value for Cortex-M). This is useful if you want to override the default label—defined in the system startup code—in the application or if the application lacks this label, which can be the case if you debug code that is built by tools from another vendor.

The default label for the vector location is:

- `__vector_table` (Cortex-M)
- `__vector` (Cortex-Av7 and Cortex-Rv7)
- `__vector_v8` (Cortex-Av8 and Cortex-Rv8)



**Project>Options>Debugger>Extra Options.**

**-f**

Syntax	<code>-f filename</code>
Parameters	<p><i>filename</i></p> <p>A text file that contains the command line options (default filename extension <code>.xcl</code>).</p>
For use with	<code>cspybat</code>
Description	<p>Use this option to make <code>cspybat</code> read command line options from the specified file.</p> <p>In the command file, you format the items exactly as if they were on the command line itself, except that you may use multiple lines, because the newline character is treated like a space or tab character.</p> <p>Both C/C++ style comments are allowed in the file. Double quotes behave in the same way as in the Microsoft Windows command line environment.</p> <p>This option can be placed either before or after the <code>--backend</code> option on the command line.</p>



To set this option, use **Project>Options>Debugger>Extra Options**.

**--flash\_loader**

Syntax	<code>--flash_loader filename</code>
Parameters	<p><i>filename</i></p> <p>The flash loader specification XML file, with the filename extension <code>.board</code>.</p>
For use with	<code>cspybat</code>
Description	<p>Use this option to specify a flash loader specification XML file which contains all relevant information about the flash loading. There can be more than one such argument, in which case each argument will be processed in the specified order, resulting in several flash programming passes.</p>
See also	The <i>IAR Flash Loader Development Guide</i> .



To set related options, choose:

**Project>Options>Debugger>Download>Use flash loader(s)**

## --function\_profiling

Syntax	<code>--function_profiling <i>filename</i></code>
Parameters	<i>filename</i> The name of the log file where the profiling data is saved.
For use with	The C-SPY simulator driver. (Not available for all cores and devices.)
Description	Use this option to find the functions in your source code where the most time is spent during execution. The profiling information is saved to the specified file. For more information about function profiling, see <i>Profiling</i> , page 293.



**C-SPY driver>Function Profiling**

## --gdbserv\_exec\_command

Syntax	<code>--gdbserv_exec_command=" <i>string</i>"</code>
Parameters	<i>string</i> String or command sent to the GDB Server. For more information, see the GDB server documentation.
For use with	The C-SPY GDB Server driver.
Description	Use this option to send strings or commands to the GDB Server.



**Project>Options>Debugger>Extra Options**

## --jet\_board\_cfg

Syntax	<code>--jet_board_cfg=<i>probe_configuration_file</i></code>
Parameters	<i>probe_configuration_file</i> The full path to a probe configuration file.



For use with	The C-SPY I-jet driver. The C-SPY CMSIS-DAP driver.
Description	Use this option to specify a probe configuration file that defines the debug system on the board.  <b>Project&gt;Options&gt;Debugger&gt;CMSIS DAP&gt;Interface&gt;Probe configuration file</b> <b>Project&gt;Options&gt;Debugger&gt;I-jet&gt;Interface&gt;Probe configuration file</b>

## --jet\_board\_did

Syntax	<code>--jet_board_did={cpu #cpu_number}</code>
Parameters	<p><i>cpu</i> If a board configuration file is specified (using <code>--jet_board_cfg</code>) and the defined debug system contains more than one CPU, use this parameter to select a CPU. The value of <i>cpu</i> is a text string. The range of valid values are located in the probe configuration file.</p> <p><i>#cpu_number</i> If the debug system is a multicore SWD system, specify the CPU number on the DAP. If the debug system is a JTAG scan chain, and there are several CPUs at the specified TAP position, then specify the CPU number on target. Note that <i>#cpu_number</i> has no effect if a board configuration file is specified using <code>--jet_board_cfg</code>.</p>
For use with	The C-SPY I-jet driver. The C-SPY CMSIS-DAP driver.
Description	Use this option to specify which CPU to debug on a multicore system. <code>--jet_board_did=#cpu_number</code> is also applicable when <code>--jet_probe=cmsisdap</code> is specified.
Example	Selecting the CPU on a multicore device with a probe configuration file: <code>--jet-board-cfg=device.ProbeConfig --jet_board_did=A9_1</code>

Selecting the CPU on a multicore device with a JTAG scan chain, where several CPUs are found at the specified TAP position:

```
--jet_tap_position=1 --jet_ir_length=5 --jet_board_did=#2
```



**Project>Options>Debugger>CMSIS DAP>Interface>Probe configuration file>CPU**

**Project>Options>Debugger>CMSIS DAP>Interface>Probe config>Explicit>CPU number on target**

**Project>Options>Debugger>I-jet>Interface>Probe configuration file>CPU**

**Project>Options>Debugger>I-jet>Interface>Explicit probe configuration>CPU number on target**

## --jet\_cpu\_clock

Syntax	<code>--jet_cpu_clock=<i>frequency</i></code>	
Parameters	<i>frequency</i>	The clock frequency in Hz
For use with	The C-SPY I-jet driver.	
Description	Use this option to specify the exact clock frequency used by the internal processor clock, HCLK. This value is used for configuring the SWO communication speed and for calculating timestamps.	



**Project>Options>Debugger>I-jet>Trace>CPU clock**

## --jet\_disable\_pmu

Syntax	<code>--jet_disable_pmu</code>	
For use with	The C-SPY I-jet driver.	
Description	Use this option to disable the PMU event counting completely.	
	To set this option, use <b>Project&gt;Options&gt;Debugger&gt;Extra Options</b> .	



## --jet\_disable\_pmu\_dap

Syntax	<code>--jet_disable_pmu_dap</code>
For use with	The C-SPY I-jet driver.
Description	Use this option to disable the PMU DAP channel and revert to using CP15 instructions for PMU event counting. This disables live updating of counter values when the debugger is running.



To set this option, use **Project>Options>Debugger>Extra Options**.

## --jet\_ir\_length

Syntax	<code>--jet_ir_length=length</code>
Parameters	<i>length</i> The number of IR bits preceding the Arm core to connect to, for JTAG scan chains that mix Arm devices with other devices.
For use with	The C-SPY I-jet driver.
Description	Use this option to set the number of IR bits preceding the Arm core to connect to.
See also	<i>I-jet — Interface</i> , page 605



**Project>Options>Debugger>I-jet>Interface>Explicit probe configuration>Preceding bits**

## --jet\_power\_from\_probe

Syntax	<code>--jet_power_from_probe=[leave_on switch_off]</code>
Parameters	<i>leave_on</i> Continues to supply power to the target even after the debug session has been stopped.
	<i>switch_off</i> Turns off the power to the target when the debug session stops.

For use with	The C-SPY I-jet driver.
Description	Use this option to specify the status of the probe power supply after debugging. If this option is not specified, the probe will not supply power to the board.



**Project>Options>Debugger>I-jet>Setup>Target power**

## --jet\_probe

Syntax	<code>--jet_probe=[ijet cmsisdap]</code>	
Parameters	<code>ijet</code>	Specifies the C-SPY I-jet driver as the interface to an I-jet or I-jet Trace probe.
	<code>cmsisdap</code>	Specifies the C-SPY I-jet driver as the interface to a CMSIS-DAP system.
For use with	The C-SPY I-jet driver. The C-SPY CMSIS-DAP driver.	
Description	Use this option to specify the C-SPY I-jet driver as the interface to a debug system.	



**Project>Options>Debugger>Driver**

## --jet\_script\_file

Syntax	<code>--jet_script_file=path</code>	
Parameters	<code>path</code>	The path to the file where the scripted reset strategies are described.
For use with	The C-SPY I-jet driver. The C-SPY CMSIS-DAP driver.	
Description	Use this option to specify the file that describes the available scripted reset strategies, if any.	

See also

`--reset_style`, page 566 and `--jet_standard_reset`, page 553.



To set this option, use **Project>Options>Debugger>Extra Options**.

## --jet\_standard\_reset

Syntax

`--jet_standard_reset=strategy,duration,delay`

Parameters

*strategy*

The reset strategy. Choose between:

- 0, reset disabled
- 1, software reset
- 2, hardware reset
- 3, core reset
- 4, system reset.

The following reset strategies are available, if present in the file specified by `--jet_script_file` and defined by corresponding instances of `--reset_style`:

- 5, custom reset
- 6, reset by watchdog or reset register
- 7, reset and halt after bootloader
- 8, reset and halt before bootloader
- 9, connect during reset

*duration*

The time in milliseconds that the hardware reset asserts the reset signal (line `nSRST/nRESET`) low to reset the device.

Some devices might require a longer reset signal than the default 200 ms.

This parameter applies to the hardware reset, and to those custom reset strategies that use the hardware reset.

	<i>delay</i>	<p>The delay time, in milliseconds, after the reset signal has been de-asserted, before the debugger attempts to control the processor.</p> <p>The processor might be kept internally in reset for some time after the external reset signal has been de-asserted, and thus inaccessible for the debugger.</p> <p>This parameter applies to the Hardware reset, and to those custom reset strategies that use the Hardware reset.</p>
For use with	<p>The C-SPY CMSIS-DAP driver.</p> <p>The C-SPY I-jet driver.</p>	
Description	Use this option to select the reset strategy to be used when the debugger starts. Note that Cortex-M uses a different set of strategies than other devices.	
See also	<i>--reset_style</i> , page 566 and <i>--jet_script_file</i> , page 552.	
		<p><b>Project&gt;Options&gt;Debugger&gt;CMSIS DAP&gt;Setup&gt;Reset</b></p> <p><b>Project&gt;Options&gt;Debugger&gt;I-jet&gt;Setup&gt;Reset</b></p>

## **--jet\_startup\_connection\_timeout**

Syntax	<i>--jet_startup_connection_timeout=milliseconds</i>	
Parameters	<i>milliseconds</i>	The time in milliseconds.
For use with	<p>The C-SPY I-jet driver.</p> <p>The C-SPY CMSIS-DAP driver.</p>	
Description	Use this option to prolong the time that the C-SPY driver tries to connect to the target board.	
		To set this option, use <b>Project&gt;Options&gt;Debugger&gt;Extra Options</b> .

## --jet\_swo\_on\_d0

Syntax	--jet_swo_on_d0
For use with	The C-SPY I-jet driver.
Description	Use this option to specify that SWO trace data is output on the trace data pin D0. When using this option, both the SWD and the JTAG interface can handle SWO trace data.



**Project>Options>Debugger>I-jet>Trace>SWO on the TraceD0 pin**

## --jet\_swo\_prescaler

Syntax	--jet_swo_prescaler= <i>number</i>
Parameters	<i>number</i> The prescaler value, 1–100, which in turn determines the CPU clock frequency.
For use with	The C-SPY I-jet driver.
Description	Use this option to specify the prescaler for the SWO clock. The CPU clock frequency is divided by the number specified as the prescaler. If data packets are lost during transmission, try using a higher prescaler value.  If this option is not specified, a prescaler value is set automatically. This automatically set value is the highest possible frequency that the debug probe can handle.



**Project>Options>Debugger>I-jet>Trace>SWO prescaler**

## --jet\_swo\_protocol

Syntax	--jet_swo_protocol={ <i>auto</i>  Manchester UART}
Parameters	<i>auto</i> Automatically selects the communication protocol. <i>Manchester</i> Specifies the Manchester protocol. <i>UART</i> Specifies the UART protocol.

For use with	The C-SPY I-jet driver.
Description	Use this option to specify the communication protocol for the SWO channel. If this option is not specified, <code>auto</code> is automatically used.



**Project>Options>Debugger>I-jet>Trace>SWO protocol**

## --jet\_tap\_position

Syntax	<code>--jet_tap_position=tap_number multidrop_id</code>	
Parameters	<i>tap_number</i>	The TAP position of the device you want to connect to.
	<i>multidrop_id</i>	The target ID in a multi-drop system.
For use with	The C-SPY I-jet driver. The C-SPY CMSIS-DAP driver.	
Description	If you are using the JTAG interface, and there is more than one device on the JTAG scan chain, use this option to select a specific device. If you are using the SWD interface, and there is a multi-drop SWD system on the board, use this option to select a target ID.	
See also	<i>I-jet — Interface</i> , page 605.	



**Project>Options>Debugger>I-jet>Interface>Explicit probe configuration>Target number (TAP or Multidrop ID)**

## --jlink\_dcc\_timeout

Syntax	<code>--jlink_dcc_timeout=milliseconds</code>	
Parameters	<i>milliseconds</i>	The timeout in milliseconds. The valid range is 5-5000. The default value is 100 milliseconds.
For use with	The C-SPY J-Link/J-Trace driver.	
Description	Use this option to specify a timeout for a pending request from C-SPY to the DCC agent on target.	





To set this option, use **Project>Options>Debugger>Extra Options**.

## --jlink\_device\_select

Syntax	<code>--jlink_device_select=tap_number</code>
Parameters	<i>tap_number</i> The TAP position of the device you want to connect to.
For use with	The C-SPY J-Link/J-Trace driver.
Description	If there is more than one device on the JTAG scan chain, use this option to select a specific device.
See also	<i>I-jet — Interface</i> , page 605.



**Project>Options>Debugger>J-Link/J-Trace>Connection>JTAG scan chain>TAP number**

## --jlink\_exec\_command

Syntax	<code>--jlink_exec_command=cmdstr1; cmdstr2; cmdstr3 ...</code>
Parameters	<i>cmdstrn</i> J-Link/J-Trace command string.
For use with	The C-SPY J-Link/J-Trace driver.
Description	Use this option to make the debugger call the <code>__jlinkExecCommand</code> macro with one or several command strings, after target connection has been established.
See also	<i>__jlinkExecCommand</i> , page 466.



To set this option, use **Project>Options>Debugger>Extra Options**.

## --jlink\_initial\_speed

Syntax	<code>--jlink_initial_speed=<i>speed</i></code>	
Parameters	<i>speed</i>	The initial communication speed in kHz. If no speed is specified, 32 kHz will be used as the initial speed.
For use with	The C-SPY J-Link/J-Trace driver.	
Description	Use this option to set the initial JTAG communication speed in kHz.	
See also	<i>J-Link/J-Trace — Setup</i> , page 611.	



**Project>Options>Debugger>J-Link/J-Trace>Setup>JTAG speed>Fixed**

## --jlink\_ir\_length

Syntax	<code>--jlink_ir_length=<i>length</i></code>	
Parameters	<i>length</i>	The number of IR bits preceding the Arm core to connect to, for JTAG scan chains that mix Arm devices with other devices.
For use with	The C-SPY J-Link/J-Trace driver.	
Description	Use this option to set the number of IR bits preceding the Arm core to connect to.	
See also	<i>J-Link/J-Trace — Connection</i> , page 615.	



**Project>Options>Debugger>J-Link/J-Trace>Connection>JTAG scan chain>Preceding bits**

## --jlink\_reset\_strategy

Syntax	<code>--jlink_reset_strategy=<i>delay</i>,<i>strategy</i></code>	
Parameters	<i>delay</i>	For Cortex-M and Arm 7/9/11 with strategies 1-9, <i>delay</i> should be 0 (ignored). For Arm 7/9/11 with strategy 0, the delay should be one of 0-10000.
	<i>strategy</i>	For information about supported reset strategies, see the <i>J-Link/J-Trace User Guide</i> .
For use with	The C-SPY J-Link/J-Trace driver.	
Description	Use this option to select the reset strategy to be used at debugger startup.	
See also	<i>J-Link/J-Trace — Setup</i> , page 611.	



**Project>Options>Debugger>J-Link/J-Trace>Setup>Reset**

## --jlink\_script\_file

Syntax	<code>--jlink_script_file=<i>filename</i></code>	
Parameters	<i>filename</i>	The name of the J-Link script file.
For use with	The C-SPY J-Link/J-Trace driver.	
Description	Use this option to specify the J-Link script file to be used.  J-Link has a script language that can be used for setting up hardware. For certain targets, ready-made script files are automatically pointed out by IAR Embedded Workbench. In command line mode, the script file needs to be manually specified by using this option.	
See also	The <i>J-Link/J-Trace User Guide</i> ( <i>JLinkARM.pdf</i> , document number UM08001), for a detailed description of the script language.	





To set this option using a non-predefined script file, use **Project>Options>Debugger>Extra Options**.

## --jlink\_trace\_source

Syntax	<code>--jlink_trace_source={ETB ETM}</code>				
Parameters	<table> <tr> <td>ETB</td> <td>Selects ETB trace.</td> </tr> <tr> <td>ETM</td> <td>Selects ETM trace.</td> </tr> </table>	ETB	Selects ETB trace.	ETM	Selects ETM trace.
ETB	Selects ETB trace.				
ETM	Selects ETM trace.				
For use with	The C-SPY J-Link/J-Trace driver.				
Description	<p>Use this option to select either ETB or ETM as the trace source.</p> <p><b>Note:</b> This option only applies to J-Trace.</p>				
See also	<i>J-Link/J-Trace — Setup</i> , page 611.				
	 <b>Project&gt;Options&gt;Debugger&gt;J-Link/J-Trace&gt;Setup&gt;ETM/ETB</b>				

## --leave\_target\_running

Syntax	<code>--leave_target_running</code>
For use with	<p><code>cspybat</code>.</p> <p>Any C-SPY hardware debugger driver.</p> <p><b>Note:</b> Even if this option is supported by the C-SPY driver you are using, there might be device-specific limitations.</p>
Description	<p>Use this option to make the debugger leave the application running on the target hardware after the debug session is closed.</p> <p> Because existing breakpoints might not be automatically removed, consider disabling all breakpoints before using this option.</p> <p> <b>C-SPY driver&gt;Leave Target Running</b></p>

## --lmiftdi\_reset\_strategy

Syntax	<code>--lmiftdi_reset_strategy=delay, strategy</code>	
Parameters	<i>delay</i>	The delay time measured in milliseconds. <i>delay</i> is ignored and should be 0.
	<i>strategy</i>	The reset strategy:  0, (Software) Resets the core. This sets PC to the program entry address and SP to the initial stack pointer value.  1, (System) Resets the core and peripheral units. This sets PC to the program entry address and SP to the initial stack pointer value.
For use with	The C-SPY TI-Stellaris driver.	
Description	Use this option to select the reset strategy to be used at debugger startup.	
See also	<i>TI Stellaris — Setup</i> , page 625	



**Project>Options>Debugger>TI Stellaris>Setup>Reset**

## --macro

Syntax	<code>--macro filename</code>	
	Note that this option must be placed before the <code>--backend</code> option on the command line.	
Parameters	<i>filename</i>	The C-SPY macro file to be used (filename extension <code>mac</code> ).
For use with	<code>cspybat</code>	
Description	Use this option to specify a C-SPY macro file to be loaded before executing the target application. This option can be used more than once on the command line.	
See also	<i>Briefly about using C-SPY macros</i> , page 428.	



**Project>Options>Debugger>Setup>Setup macros>Use macro file**

**--macro\_param**

Syntax	<code>--macro_param [param=value]</code>
	Note that this option must be placed before the <code>--backend</code> option on the command line.
Parameters	<code>param=value</code> <code>param</code> is a parameter defined using the <code>__param</code> C-SPY macro construction. <code>value</code> is a value.
For use with	<code>cspybat</code>
Description	Use this option to assign a value to a C-SPY macro parameter. This option can be used more than once on the command line.
See also	<i>Macro parameters</i> , page 435.



To set this option, use **Project>Options>Debugger>Extra Options**

**--mapu**

Syntax	<code>--mapu</code>
For use with	The C-SPY simulator driver. (Not available for all cores and devices.)
Description	Specify this option to use the section information in the debug file for memory access checking. During the execution, the simulator will then check for accesses to unspecified memory ranges. If any such access is found, the C function call stack and a message will be printed on <code>stderr</code> and the execution will stop.
See also	<i>Monitoring memory and registers</i> , page 167.



To set related options, choose:

**Simulator>Memory Access Setup**

**--mspfet\_erase\_flash**

Syntax	<code>--mspfet_erase_flash=main main_info main_info_ip</code>
Parameters	<code>main</code> Erases the main flash memory

	<code>main_info</code>	Erases both flash memories—main and Information memory.
	<code>main_info_ip</code>	Erases the main and Information flash memories, including the IP protected area.

For use with The C-SPY TI MSP-FET driver.

Description Use this option to specify which flash memories to erase before download.



**Project>Options>Debugger>TI MSP-FET>Download>Flash erase**

## --mspfet\_interface\_speed

Syntax `--mspfet_interface_speed=fast|medium|slow`

Parameters

<code>fast</code>	The fast interface speed.
<code>medium</code>	The medium interface speed.
<code>slow</code>	The slow interface speed.

For use with The C-SPY TI MSP-FET driver.

Description Use this option to set the interface communication speed.



**Project>Options>Debugger>TI MSP-FET>Setup>Interface speed**

## --mspfet\_reset\_strategy

Syntax `--mspfet_reset_strategy=delay, strategy`

Parameters

<code>delay</code>	The delay time in milliseconds.
<code>strategy</code>	The reset strategy, where 0 is Normal.

For use with The C-SPY TI MSP-FET driver.

Description Use this option to select the reset strategy to use at debugger startup.

**Project>Options>Debugger>TI MSP-FET>Setup>Reset****--mspfet\_settlingtime**

Syntax	<code>--mspfet_settlingtime=<i>delay</i></code>	
Parameters	<i>delay</i>	The delay in milliseconds.
For use with	The C-SPY TI MSP-FET driver.	
Description	Use this option to specify a delay that will be used between switching on the target VCC and starting the identification of the Arm device.	

**Project>Options>Debugger>TI MSP-FET>Setup>Target VCC>Settling time****--mspfet\_vccvoltage**

Syntax	<code>-mspfet_vccvoltage=<i>voltage</i></code>	
Parameters	<i>voltage</i>	The target VCC voltage in mV.
For use with	The C-SPY TI MSP-FET driver.	
Description	Use this option to specify the target VCC voltage.	

**Project>Options>Debugger>TI MSP-FET>Setup>Target VCC>Target VCC****--multicore\_nr\_of\_cores**

Syntax	<code>--multicore_nr_of_cores=<i>cores</i></code>	
Parameters	<i>cores</i>	The number of cores on your device. This must be an integer from 2–8.
For use with	The C-SPY simulator driver. (Not available for all cores and devices.)	



**Description** For symmetric multicore debugging, specify the number of cores on your device. This option is not needed for debugging a single-core system, or for asymmetric multicore debugging.

**See also** *Multicore debugging*, page 391.



**Project>Options>Debugger>Multicore>Number of cores**

## -p

**Syntax** `-p filename`

**Parameters** `filename`  
The device description file to be used.

**For use with** All C-SPY drivers.

**Description** Use this option to specify the device description file to be used.

**See also** *Selecting a device description file*, page 57.



**Project>Options>Debugger>Setup>Device description file**

## --plugin

**Syntax** `--plugin filename`

Note that this option must be placed before the `--backend` option on the command line.

**Parameters** `filename`  
The plugin file to be used (filename extension `dll`).

**For use with** `cspybat`

**Description** Certain C/C++ standard library functions, for example `printf`, can be supported by C-SPY—for example, the C-SPY **Terminal I/O** window—instead of by real hardware devices. To enable such support in `cspybat`, a dedicated plugin module called `armlibsupportbat.dll` located in the `arm\bin` directory must be used.

Use this option to include this plugin during the debug session. This option can be used more than once on the command line.

**Note:** You can use this option to also include other plugin modules, but in that case the module must be able to work with `csybat` specifically. This means that the C-SPY plugin modules located in the `common\plugin` directory cannot normally be used with `csybat`.



**Project>Options>Debugger>Plugins**

## --proc\_stack\_stack

### Syntax

`--proc_stack_stack=startaddress, endaddress`

where *stack* is:

- one of `main` or `proc` for Cortex-M, and
- one of `usr`, `svc`, `irq`, `fiq`, `und`, or `abt` for other Arm cores

### Parameters

*startaddress*      The start address of the stack, specified either as a value or as an expression.

*endaddress*        The end address of the stack, specified either as a value or as an expression.

### For use with

All C-SPY drivers. Note that this command line option is only available when using C-SPY from the IDE—not in batch mode using `csybat`.

### Description

Use this option to provide C-SPY with information about reserved stacks. By default, C-SPY receives this information from the system startup code, but if you for some reason want to override the default values, this option can be useful.

### Example

`--proc_stack_irq=0x8000, 0x80FF`



To set this option, use **Project>Options>Debugger>Extra Options**.

## --reset\_style

### Syntax

`--reset_style="reset_id, reset_name, selected, menu_command"`

### Parameters

*reset\_id*            The number of the reset strategy, 0-9, as described for `--jet_standard_reset`

	<i>reset_name</i>	The name of the reset strategy, according to the file specified by <code>--jet_script_file</code> .  For the built-in reset strategies, this parameter is <code>-</code> . To override a built-in reset strategy, enter the label or function name in your reset script file.
	<i>selected</i>	0 or 1, where 1 sets the default reset strategy for the <b>Reset</b> drop-down menu
	<i>menu_command</i>	The name of the reset strategy as it will be displayed on the <b>Reset</b> drop-down menu.
For use with	The C-SPY I-jet driver.  The C-SPY CMSIS-DAP driver.	
Description	Use this option to specify the reset strategies that will be available when debugging, once for each reset strategy.	
Example	This example specifies a script file, sets the standard reset strategy, and specifies the reset strategies that will be available when debugging:  <pre>--jet_script_file=myDir\myProbeScriptFile --jet_standard_reset=9,0,0 --reset_style="0,-,0,Disabled (no reset)" --reset_style="1,-,0,Software" --reset_style="2,-,0,Hardware" --reset_style="3,-,0,Core" --reset_style="4,-,0,System" --reset_style="5,Custom,0,Custom reset" --reset_style="9,ConnectUnderReset,1,Connect during reset"</pre>	
See also	<code>--jet_script_file</code> , page 552 and <code>--jet_standard_reset</code> , page 553	



To set this option, use **Project>Options>Debugger>Extra Options**.

## --sdm\_debug\_architecture

Syntax	<code>--sdm_debug_architecture=<i>interface</i></code>	
Parameters	<i>interface</i>	The SDM debug architecture used for SDM debug authentication. Choose between:  <i>adi_v5</i> — Arm Debug Interface V5 (default) <i>adi_v6</i> — Arm Debug Interface V6 <i>nexus</i> — the Nexus (IEEE-ISTO 5001-2003) standard debug interface
For use with	The C-SPY CMSIS-DAP driver. The C-SPY I-jet driver. The C-SPY ST-LINK driver.	
Description	Use this option to specify the debug architecture used for SDM debug authentication.	
See also	<i>Debug authentication</i> , page 63.	
		To set this option, use <b>Project&gt;Options&gt;Debugger&gt;Extra Options</b> .

## --sdm\_library

Syntax	<code>--sdm_library=<i>path</i></code>	
Parameters	<i>path</i>	The path to the SDM library file (.dll).
For use with	The C-SPY CMSIS-DAP driver. The C-SPY I-jet driver. The C-SPY ST-LINK driver.	
Description	Use this option to specify the path to the library file (.dll) used for SDM debug authentication.  <b>Note:</b> This option cannot be used together with the option <code>--sdm_manifest</code> .	
See also	<i>Debug authentication</i> , page 63 and <i>--sdm_manifest</i> , page 569.	



Project>Options>Debugger>Authentication>Library file.

## --sdm\_library\_hint

Syntax	<code>--sdm_library_hint=<i>ID</i></code>
Parameters	<i>ID</i> An implementation-specific identifier.
For use with	The C-SPY CMSIS-DAP driver. The C-SPY I-jet driver. The C-SPY ST-LINK driver.
Description	Use this option if the SDM library does not use the standard SDM API. In that case, IAR Embedded Workbench must handle the authentication in a special way. For the STM32H5 device family and the corresponding library, the identifier is <code>st_sdm</code> .  In the IDE, the implementation-specific identifier is fetched from the device selection file ( <code>.i79</code> ).
See also	<i>Debug authentication</i> , page 63.



This option is not available in the IDE.

## --sdm\_manifest

Syntax	<code>--sdm_manifest=<i>path</i></code>
Parameters	<i>path</i> The path to the SDM manifest file ( <code>.xml</code> ).
For use with	The C-SPY CMSIS-DAP driver. The C-SPY I-jet driver. The C-SPY ST-LINK driver.
Description	Use this option to specify the path to the manifest file ( <code>.xml</code> ) that points out the library file used for SDM debug authentication.

See also

**Note:** This option cannot be used together with the option `--sdm_library`.*Debug authentication*, page 63 and *--sdm\_library*, page 568.**Project>Options>Debugger>Authentication>Manifest file.**

## --semihosting

Syntax

`--semihosting={none|iar_breakpoint}`

Parameters

No parameter	Use standard semihosting*.
none	Does not use semihosted I/O.
iar_breakpoint	Uses the IAR proprietary semihosting variant.

For use with

All C-SPY drivers.

Description

Use this option to enable semihosted I/O and to choose the kind of semihosting interface to use.

Note that if this option is not used, semihosting will by default be enabled and C-SPY will try to choose the correct semihosting mode automatically. This means that normally you do not have to use this option if your application is linked with semihosting.

To make semihosting work, your application must be linked with a semihosting library.

\* If no parameter is specified, the behavior is as described in the chapter *The DLIB runtime environment* in the *IAR C/C++ Development Guide for Arm*.

See also

For information about linking with semihosting, see the *IAR C/C++ Development Guide for Arm*.**Project>Options>General Options>Library Configuration**

## --silent

Syntax

`--silent`Note that this option must be placed before the `--backend` option on the command line.

For use with

cspybat

Description Use this option to omit the sign-on message.



This option is not available in the IDE.

## --sockets

Syntax `--sockets`

Note that this option must be placed before the `--backend` option on the command line.

For use with `cspybat`

Description Use this option to make the debugger use sockets instead of pipes for its internal communication. This can make the debugger work better when you run several `cspybat` instances in parallel on the same host computer.



This option is not available in the IDE.

## --stlink\_reset\_strategy

Syntax `--stlink_reset_strategy=delay, strategy`

Parameters

<i>delay</i>	The delay time measured in milliseconds. <i>delay</i> is ignored and should be 0.
<i>strategy</i>	<p>The reset strategy:</p> <ol style="list-style-type: none"> <li>0, (System) performs the standard reset procedure. Only available for debugging Cortex-M devices.</li> <li>1, (Hardware) uses the reset pin to perform a hardware reset. Only available for ST-LINK version 2.</li> <li>2, (Connect during reset) ST-LINK connects to the target while keeping Reset active (Reset is pulled low and remains low while connecting to the target). Only available for ST-LINK version 2 and when debugging Cortex-M devices.</li> <li>3, (Core) resets the core via the <code>VECTRESET</code> (Cortex-M) or <code>CWRR</code> (Cortex-A) bit—the peripheral units are not affected.</li> <li>4, (Software) Sets the <code>PC</code> to program entry address and <code>SP</code> to the initial stack pointer value.</li> </ol>

For use with	The C-SPY ST-LINK driver.
Description	Use this option to select the reset strategy to be used at debugger startup.
See also	<i>ST-LINK — Setup</i> , page 618



**Project>Options>Debugger>ST-LINK>Setup>Reset**

## **--suppress\_entrypoint\_warning**

Syntax	<code>--suppress_entrypoint_warning</code>
For use with	<code>cspybat</code>
Description	Use this option to disable the warning in the debug log when a debug session starts with the ELF entry point at address <code>0x0</code> (which according to the ELF standard means that there is no entry point). In practice, there is no problem with having the entry point at address <code>0x0</code> .



To set this option, use **Project>Options>Debugger>Extra Options**

## **--timeout**

Syntax	<code>--timeout milliseconds</code>
	Note that this option must be placed before the <code>--backend</code> option on the command line.
Parameters	<i>milliseconds</i> The number of milliseconds before the execution stops.
For use with	<code>cspybat</code>
Description	Use this option to limit the maximum allowed execution time.



This option is not available in the IDE.

## **--xds\_board\_file**

Syntax	<code>--xds_board_file=dat_file</code>
--------	--



Parameters	<i>dat_file</i>	The (path and) filename of the board file.
For use with	The C-SPY TI XDS driver.	
Description	Use this option to override the default board file by specifying a custom board file.	
		<b>Project&gt;Options&gt;Debugger&gt;TI XDS&gt;Setup&gt;Emulator&gt;Specify custom board file</b> <b>Project&gt;Options&gt;Debugger&gt;TI XDS&gt;Setup&gt;Emulator&gt;Board file</b>

## --xds\_reset\_strategy

Syntax	<code>--xds_reset_strategy=delay, strategy</code>	
Parameters	<i>delay</i>	The delay time measured in milliseconds.
	<i>strategy</i>	The reset strategy. For Cortex-M devices: 0, CPU reset 1, System Reset 2, Board reset. Only available for CC26xx and CC13xx devices. 3, Board reset, run and halt with delay. Available for all other Cortex-M devices. For other devices (not Cortex-M): 0, Software reset 1, Hardware reset
For use with	The C-SPY TI XDS driver.	
Description	Use this option to select the reset strategy to be used at debugger startup.	
See also	<i>TI XDS — Setup</i> , page 627	
		<b>Project&gt;Options&gt;Debugger&gt;TI XDS&gt;Setup&gt;Reset</b>

## **--xds\_rootdir**

Syntax	<code>--xds_rootdir=<i>path</i></code>
For use with	The C-SPY TI XDS driver.
Description	<p>Use this option to specify the path to the directory where the TI XDS driver package is installed. If you installed the package in an alternative location, you can use the global argument variable <code>XDS_EMUPACK_DIR</code> to set a new default value.</p> <p> To set this option, use <b>Project&gt;Options&gt;Debugger&gt;TI XDS&gt;Setup&gt;TI emulation package installation path</b>.</p>

# Flash loaders

- Introduction to the flash loader
- Using flash loaders
- Reference information on the flash loader

---

## Introduction to the flash loader

A flash loader is an agent that is downloaded to the target. It fetches your application from the debugger and programs it into flash memory. The flash loader uses the file I/O mechanism to read the application program from the host. You can select one or several flash loaders, where each flash loader loads a selected part of your application. This means that you can use different flash loaders for loading different parts of your application.

Flash loaders for various microcontrollers are provided with IAR Embedded Workbench for Arm. In addition to these, more flash loaders are provided by chip manufacturers and third-party vendors. The flash loader API, documentation, and several implementation examples are available to make it possible for you to implement your own flash loader.

---

## Using flash loaders

These tasks are covered:

- Setting up the flash loader(s)
- The flash loading mechanism
- Aborting a flash loader

### SETTING UP THE FLASH LOADER(S)

**To use a flash loader for downloading your application:**

- 1** Choose **Project>Options**.
- 2** Choose the **Debugger** category and click the **Download** tab.
- 3** Select the **Use Flash loader(s)** option. A default flash loader configured for the device you have specified will be used. The configuration is specified in a preconfigured `board` file.

- 4 To override the default flash loader or to modify the behavior of the default flash loader to suit your board, select the **Override default .board file** option, and **Edit** to open the **Flash Loader Configuration** dialog box. A copy of the `*.board` file will be created in your project directory and the path to the `*.board` file will be updated accordingly.
- 5 The **Flash Loader Overview** dialog box lists all currently configured flash loaders, see *Flash Loader Overview dialog box*, page 577. You can either select a flash loader or open the **Flash Loader Configuration** dialog box.

In the **Flash Loader Configuration** dialog box, you can configure the download. For information about the various flash loader options, see *Flash Loader Configuration dialog box*, page 579.

## THE FLASH LOADING MECHANISM

When the **Use flash loader(s)** option is selected and one or several flash loaders have been configured, these steps are performed when the debug session starts.

Steps 1 to 4 are performed for each flash loader in the flash loader configuration.

- 1 C-SPY downloads the flash loader into target RAM.
  - Steps 2 to 4 are performed one or more times depending on the size of the RAM and the size of the application image.
- 2 C-SPY writes code/data from the application image into target RAM (RAM buffer).
- 3 C-SPY starts execution of the flash loader.
- 4 The flash loader reads data from the RAM buffer and programs the flash memory.
- 5 The application image now resides in flash memory and can be started. The flash loader and the RAM buffer are no longer needed, so RAM is fully available to the application in the flash memory.

## ABORTING A FLASH LOADER

### To abort a flash loader:

- 1 Press Ctrl+Shift+. (period) for a short while.
- 2 A message that says that the flash loader has aborted is displayed in the **Debug Log** window.

This method can be used if you suspect that something is wrong with the execution, for example because it seems not to terminate in a reasonable time.

## Reference information on the flash loader

Reference information about:

- *Flash Loader Overview dialog box*, page 577
- *Flash Loader Configuration dialog box*, page 579

### Flash Loader Overview dialog box

The **Flash Loader Overview** dialog box is available from the **Project>Options>Debugger>Download** page.

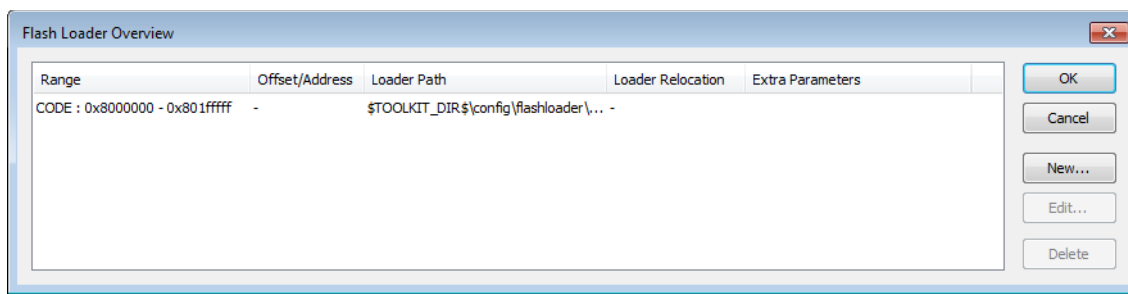

This dialog box lists all defined flash loaders. If you have selected a device on the **Project>Options>General Options>Target** page for which there is a flash loader, this flash loader is by default listed in the **Flash Loader Overview** dialog box.

#### Requirements

Available for supported hardware debugger systems.

#### Display area

Each row in the display area shows how you have set up one flash loader for flashing a specific part of memory:

##### Range

The part of your application to be programmed by the selected flash loader.

##### Offset/Address

The start of the memory where your application will be flashed. If the address is preceded by an **A**, the address is absolute. Otherwise, it is a relative offset to the start of the memory.

### **Loader Path**

The path to the flash loader `*.flash` file to be used (`*.out` for old-style flash loaders).

### **Loader Relocation**

For relocatable flash loaders, this is the start of the target RAM memory where the flash loader will be downloaded.

### **Extra Parameters**

List of extra parameters that will be passed to the flash loader.

Click on the column headers to sort the list by range, offset/address, etc.

## **Function buttons**

These function buttons are available:

### **OK**

The selected flash loader(s) will be used for downloading your application to memory.

### **Cancel**

Standard cancel.

### **New**

Displays a dialog box where you can specify what flash loader to use, see *Flash Loader Configuration dialog box*, page 579.

### **Edit**

Displays a dialog box where you can modify the settings for the selected flash loader, see *Flash Loader Configuration dialog box*, page 579.

### **Delete**

Deletes the selected flash loader configuration.

## Flash Loader Configuration dialog box

The **Flash Loader Configuration** dialog box is available from the **Flash Loader Overview** dialog box.

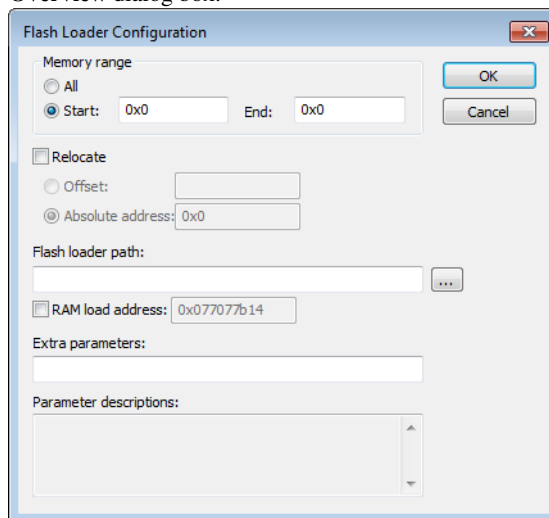

Use the **Flash Loader Configuration** dialog box to configure the download to suit your board. A copy of the default `board` file will be created in your project directory.

### Requirements

Available for supported hardware debugger systems.

### Memory range

Specify the part of your application to be downloaded to flash memory. Choose between:

#### All

The whole application is downloaded using this flash loader.

#### Start/End

Specify the start and the end of the memory area for which part of the application will be downloaded.

### Relocate

Overrides the default flash base address, in other words, relocates the location of the application in memory. This means that you can flash your application to a different location from where it was linked. Choose between:

### Offset

A numeric value for a relative offset. This offset will be added to the addresses in the application file.

### Absolute address

A numeric value for an absolute base address where the application will be flashed. The lowest address in the application will be placed on this address. Note that you can only use one flash loader for your application when you specify an absolute address.

You can use these numeric formats:

- 123456, decimal numbers
- 0x123456, hexadecimal numbers
- 0123456, octal numbers

The default base address used for writing the first byte—the lowest address—to flash is specified in the linker configuration file used for your application. However, it can sometimes be necessary to override the flash base address and start at a different location in the address space. This can, for example, be necessary for devices that remap the location of the flash memory.

### Flash loader path

Use the text box to specify the path to the flash loader file (\*.flash) to be used by your board configuration.

### RAM load address

If the flash loader is relocatable, this option overrides the default address in the target RAM memory that flash loader is downloaded to, in other words, relocates the flash loader. Use the text box to specify the address.

### Extra parameters

Some flash loaders define their own set of specific options. Use this text box to specify options to control the flash loader. For information about available flash loader options, see the **Parameter descriptions** field.

### Parameter descriptions

Displays a description of the extra parameters specified in the **Extra parameters** text box.



# Part 4. Additional reference information

This part of the *C-SPY® Debugging Guide for Arm* includes these chapters:

- Debugger options
- Additional information on C-SPY drivers

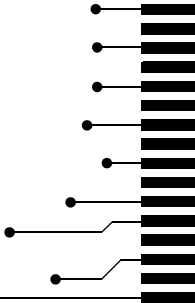

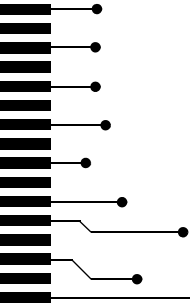

# Debugger options

- Setting debugger options
- Reference information on general debugger options
- Reference information on C-SPY hardware debugger driver options

---

## Setting debugger options

Before you start the C-SPY debugger you might need to set some options—both C-SPY generic options and options required for the target system (C-SPY driver-specific options).

### To set debugger options in the IDE:

- 1 Choose **Project>Options** to display the **Options** dialog box.
- 2 Select **Debugger** in the **Category** list.

For more information about the generic options, see *Reference information on general debugger options*, page 584.

- 3 On the **Setup** page, make sure to select the appropriate C-SPY driver from the **Driver** drop-down list.
- 4 To set the driver-specific options, select the appropriate driver from the **Category** list. Depending on which C-SPY driver you are using, different options are available.

C-SPY driver	Available options pages
C-SPY CADI driver	<i>CADI</i> — <i>Setup</i> , page 594
C-SPY CMSIS-DAP driver	<i>CMSIS-DAP</i> — <i>Setup</i> , page 595 <i>CMSIS-DAP</i> — <i>Interface</i> , page 598 <i>Breakpoints options</i> , page 154
C-SPY E2 driver	<i>E2</i> — <i>Setup</i> , page 600
C-SPY GDB Server driver	<i>GDB Server</i> , page 601 <i>Breakpoints options</i> , page 154
C-SPY G+LINK driver	<i>G+LINK</i> — <i>Setup</i> , page 601

Table 53: Options specific to the C-SPY drivers you are using

<b>C-SPY driver</b>	<b>Available options pages</b>
C-SPY I-jet driver	<i>I-jet — Setup</i> , page 602 <i>I-jet — Interface</i> , page 605 <i>I-jet — Trace</i> , page 607 <i>Breakpoints options</i> , page 154
C-SPY J-Link/J-Trace driver	<i>J-Link/J-Trace — Setup</i> , page 611 <i>J-Link/J-Trace — Connection</i> , page 615 <i>Breakpoints options</i> , page 154
C-SPY Nu-Link driver	<i>Nu-Link — Setup</i> , page 617
C-SPY PE micro driver	<i>PE micro — Setup</i> , page 617
C-SPY ST-LINK driver	<i>ST-LINK — Setup</i> , page 618 <i>ST-LINK — Communication</i> , page 621 <i>ST-LINK — Multicore</i> , page 622 <i>Breakpoints options</i> , page 154
C-SPY TI MSP-FET driver	<i>TI MSP-FET — Setup</i> , page 623 <i>TI MSP-FET — Download</i> , page 624
C-SPY TI Stellaris driver	<i>TI Stellaris — Setup</i> , page 625
C-SPY TI XDS driver	<i>TI XDS — Setup</i> , page 627 <i>TI XDS — Communication</i> , page 629
Third-party driver	<i>Third-Party Driver options</i> , page 630.

Table 53: Options specific to the C-SPY drivers you are using (Continued)

- 5 To restore all settings to the default factory settings, click the **Factory Settings** button.
- 6 When you have set all the required options, click **OK** in the **Options** dialog box.

## Reference information on general debugger options

Reference information about:

- *Setup*, page 585
- *Download*, page 586
- *Images*, page 587
- *Multicore*, page 588
- *Authentication*, page 590
- *Extra Options*, page 591
- *Plugins*, page 592

## Setup

The general **Setup** options select the C-SPY driver, the setup macro file, and device description file to use, and specify which default source code location to run to.

### Driver

Selects the C-SPY driver for the target system you have.

### Run to

Specifies the location C-SPY runs to when the debugger starts after a reset. By default, C-SPY runs to the `main` function.

To override the default location, specify the name of a different location you want C-SPY to run to. You can specify assembler labels or whatever can be evaluated as such, for example function names.

If the option is deselected, the program counter will contain the regular hardware reset address at each reset.

See also *Executing from reset*, page 56.

### Setup macros

Registers the contents of a setup macro file in the C-SPY startup sequence. Select **Use macro file** and specify the path and name of the setup file, for example `SetupSimple.mac`. If no extension is specified, the extension `mac` is assumed. A browse button is available.

It is possible to specify up to two different macro files.

### Device description file

A default device description file—either an IAR-specific `ddf` file or a CMSIS System View Description file—is selected automatically based on your project settings. To

override the default file, select **Override default** and specify an alternative file. A browse button is available.

For information about the device description file, see *Modifying a device description file*, page 61.

IAR-specific device description files for each Arm device are provided in the directory `arm\config` and have the filename extension `.ddf`.

## Download

By default, C-SPY downloads the application to RAM or flash when a debug session starts. The **Download** options let you modify the behavior of the download.

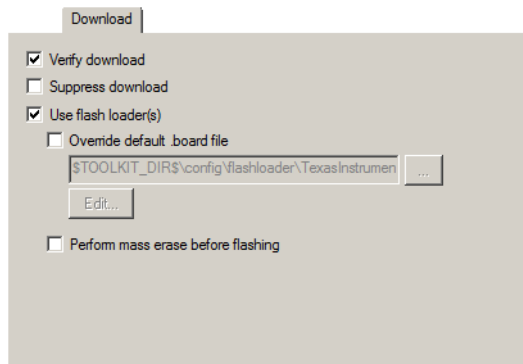

### Verify download

Verifies that the downloaded code image can be read back from target memory with the correct contents.

### Suppress download

Disables the downloading of code, while preserving the present content of the flash. This command is useful if you want to debug an application that already resides in target memory.

If this option is combined with the **Verify download** option, the debugger will read back the code image from non-volatile memory and verify that it is identical to the debugged application.

### Use flash loader(s)

Use this option to use one or several flash loaders for downloading your application to flash memory. If a flash loader is available for the selected chip, it is used by default. Press the **Edit** button to display the **Flash Loader Overview** dialog box.

See *Flash loaders*, page 575.

### Override default .board file

A default flash loader is selected based on your choice of device on the **General Options>Target** page. To override the default flash loader, select **Override default .board file** and specify the path to the flash loader you want to use. A browse button is available. Click **Edit** to display the **Flash Loader Overview** dialog box, see *Flash Loader Overview dialog box*, page 577.

### Perform mass erase before flashing

Use this option to perform a mass erase on your device. Mass erase uses an on-chip algorithm that is more efficient than erasing using the flash loader.

**Note:** This option is only available if your flash loader supports mass erase.

## Images

The **Images** options control the use of additional debug files to be downloaded.

Images

Download extra image  
 Path:  ...  
 Offset:   Debug info only

Download extra image  
 Path:  ...  
 Offset:   Debug info only

Download extra image  
 Path:  ...  
 Offset:   Debug info only

### Download extra Images

Controls the use of additional debug files to be downloaded:

#### Path

Specify the debug file to be downloaded. A browse button is available.

#### Offset

Specify an integer that determines the destination address for the downloaded debug file.

**Debug info only**

Makes the debugger download only debug information, and not the complete debug file.

If you want to download more than three debug images, use the related C-SPY macro, see `__loadImage`, page 472.

For more information, see *Loading multiple debug images*, page 59.

**Multicore**

The **Multicore** options configure multicore debugging.

**Number of cores**

For symmetric multicore debugging, specify the number of cores on your device. For asymmetric multicore debugging, specify the number of cores in the master project. (Normally, this will be 1.)

**Disabled**

Selecting this option makes the debug session symmetric multicore.

**Simple**

Selecting this option makes the debug session an asymmetric multicore debugger master. When you start a debug session, a new instance of the IAR Embedded Workbench IDE will be started, using the following options:

**Partner workspace**

Specify the workspace to be opened in the partner (slave) instance.



**Partner project**

Specify the name of the project in the workspace to be opened in the partner instance. For example, if the project filename is `MyPartnerProj.ewp`, specify `MyPartnerProj`.

**Partner configuration**

Specify the build configuration to be used when debugging the partner. For example, `Debug` or `Release`.

**Attach partner to running target**

If you have selected the command **Attach to Running Target** from the **Project** menu, which affects the master. You can also select **Attach partner to running target** to also make the debugger attach the partner to the running application at its current location, without resetting the target system.

For information about **Attach to Running Target**, see the *IDE Project Management and Building Guide for Arm*.

**Partner cores**

Specify the number of cores in the partner project.

**Override partner debugger location**

If the Embedded Workbench instance associated with the *partner* project is not installed in the same location as the Embedded Workbench instance associated with the *master* project, for example in `c:\Program Files\IAR Systems\Embedded Workbench N.n.`, you must specify the installation directory of the Embedded Workbench for the partner project. Note that the Embedded Workbench must be based on version 9.1.7 or later of the shared components—to check this, choose **Help>About>Product Info**.

**Advanced**

Selecting this option makes the debug session asymmetric multicore with one or more new instances of the IAR Embedded Workbench IDE.

**Session configuration**

Use the browse button to specify the XML multicore session file that contains the settings for the debug session. For more information about this file, see *The multicore session file*, page 399.

## Authentication

The **Authentication** options configure debug authentication.

The screenshot shows the 'Authentication' dialog box. It features a title bar with the text 'Authentication'. Inside the dialog, there is a checked checkbox labeled 'Enable debug authentication'. Below this, there is a section titled 'Secure Debug Manager' which contains two radio buttons. The first radio button is labeled 'Manifest file:' and is unselected. The second radio button is labeled 'Library file:' and is selected. To the right of the 'Library file:' radio button is a text input field containing the path 'C:\Embedded Workbench 9.2\arm\bin\psa\_s' and a browse button (three dots). At the bottom of the dialog, there is an unchecked checkbox labeled 'Apply authentication if status cannot be determined'.

Debug authentication reduces the risk that an attacker uses debug capabilities to compromise the target system. IAR Embedded Workbench supports debug authentication using the open-source Secure Debug Manager (SDM) mechanism.

For more information, see *Debug authentication*, page 63.

### Enable debug authentication

Enables/disables the debug authentication mechanism. If authentication is enabled, it is performed when the debug session starts. The authentication is revoked by a target reset. The type of reset that revokes the authentication is hardware-specific.

### Secure Debug Manager

Use one of these options to specify the authentication library file that corresponds to your target device. This library is needed for the SDM debug authentication. Choose between:

#### Manifest file

Specify the location of a manifest file (`.xnl`) that points out the actual library file.

#### Library file

Specify explicitly the path to the library file (`.dll`) used for SDM debug authentication.

### Apply authentication if status cannot be determined

Use this option if, for some reason, the detection mechanism fails and you want to force using the authentication procedure. This could be the case if you are using a device that is not explicitly supported yet by IAR Embedded Workbench.

## Extra Options

The **Extra Options** page provides you with a command line interface to C-SPY.

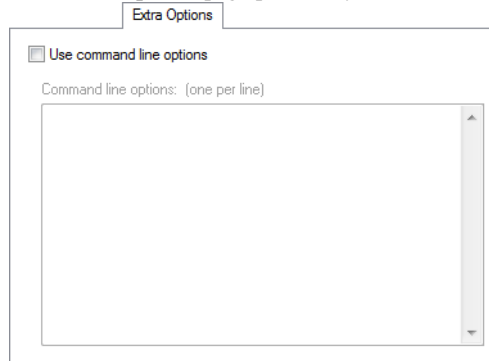

### Use command line options

Specify command line arguments that are not supported by the IDE to be passed to C-SPY.

Note that it is possible to use the `/args` option to pass command line arguments to the debugged application.

The syntax is:

```
/args arg0 arg1 ...
```

Multiple lines with `/args` are allowed, for example:

```
/args --logfile log.txt
```

```
/args --verbose
```

If you use `/args`, these variables must be defined in your application:

```
/* __argc, the number of arguments in __argv. */
__no_init __root int __argc;

/* __argv, an array of pointers to strings that holds the
arguments; must be large enough to fit the number of
parameters.*/
__no_init __root const char * __argv[MAX_ARGS];

/* __argvbuf, a storage area for __argv; must be large enough to
hold all command line parameters. */
__no_init __root char __argvbuf[MAX_ARG_SIZE];
```

## Plugins

The **Plugins** options select the C-SPY plugin modules to be loaded and made available during debug sessions.

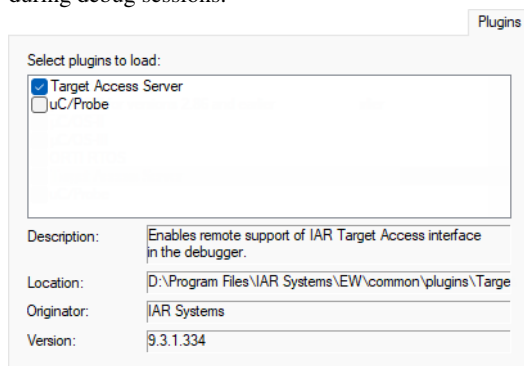

### Select plugins to load

Selects the plugin modules to be loaded and made available during debug sessions. The list contains the plugin modules delivered with the product installation.

### Description

Describes the plugin module.

### Location

Informs about the location of the plugin module.

Generic plugin modules are stored in the `common\plugins` directory. Target-specific plugin modules are stored in the `arm\plugins` directory.

**Originator**

Informs about the originator of the plugin module, which can be modules provided by IAR or by third-party vendors.

**Version**

Informs about the version number.

---

## Reference information on C-SPY hardware debugger driver options

Reference information about:

- *CADI — Setup*, page 594
- *CMSIS-DAP — Setup*, page 595
- *CMSIS-DAP — Interface*, page 598
- *E2 — Setup*, page 600
- *GDB Server*, page 601
- *G+LINK — Setup*, page 601
- *I-jet — Setup*, page 602
- *I-jet — Interface*, page 605
- *I-jet — Trace*, page 607
- *J-Link/J-Trace — Setup*, page 611
- *J-Link/J-Trace — Connection*, page 615
- *Nu-Link — Setup*, page 617
- *PE micro — Setup*, page 617
- *ST-LINK — Setup*, page 618
- *ST-LINK — Communication*, page 621
- *ST-LINK — Multicore*, page 622
- *TI MSP-FET — Setup*, page 623
- *TI MSP-FET — Download*, page 624
- *TI Stellaris — Setup*, page 625
- *TI XDS — Setup*, page 627
- *TI XDS — Communication*, page 629
- *Third-Party Driver options*, page 630

For reference information about the **Breakpoints** options page, see *Breakpoints options*, page 154.

## CADI — Setup

The **Setup** options control the C-SPY CADI driver:

### Name or PID of server to connect to

To use the C-SPY CADI driver, you must start an Arm Fast model virtual platform with a CADI server running (using the `-s` command when starting the Fast model). If multiple Fast model platforms are running, use this option to specify the name or the Process ID of the Fast model server to connect to.

### Memory

The memory type of the Fast model platform. Choose between **Physical** and **Virtual**.

### Log communication

Logs the communication between C-SPY and the target system to a file. To interpret the result, detailed knowledge of the interface is required.

## CMSIS-DAP — Setup

The **Setup** options control the C-SPY CMSIS-DAP driver.

The screenshot shows the 'Setup' dialog box for the CMSIS-DAP driver. It is divided into several sections:

- Reset:** A dropdown menu is set to 'Disabled (no reset)'. Below it are two input fields: 'Duration' with the value '300' and 'ms', and 'Delay after' with the value '200' and 'ms'.
- Emulator:** Contains an unchecked checkbox labeled 'Always prompt for probe selection' and a text input field labeled 'Serial no:'.
- Log communication:** An unchecked checkbox followed by a text input field containing '\$PROJ\_DIR\$\cspycomm.log' and a browse button (three dots).

### Reset

Selects the reset strategy to be used when the debugger starts. Note that the **Reset** option is only applicable for Cortex-M devices. Based on your hardware, one of the strategies is the default. Choose between:

#### Disabled (no reset)

No reset is performed.

#### Software

Sets PC to the program entry address. This is a software reset.

#### Hardware

The probe toggles the `nSRST/nRESET` line on the JTAG connector to reset the device. This reset usually also resets the peripheral units. The reset pulse timing is controlled by the **Duration** and **Delay after** options.

The processor should stop at the reset handler before executing any instruction. Some processors might not stop at the reset vector, but will be halted soon after, executing some instructions.

#### Core

Resets the core via the `VECTRESET` bit—the peripheral units are not affected.

#### System

Resets the core and peripherals. This is the default reset strategy.

#### Connect during reset

CMSIS-DAP connects to the target while keeping Reset active. Reset is pulled low and remains low while connecting to the target.

### Custom

Device-specific hardware reset. Some devices might require a special reset procedure or timing to enable debugging, or to bring the processor to a halt before it has executed any instruction.

A watchdog timer might be disabled.

Special debug modes, such as debugging in power-saving modes, might be turned on.

This option is only available for some devices.

### Reset by watchdog or reset register

Resets the processor using a software reset register or a watchdog reset. Peripheral units might not be reset.

This reset strategy is recommended when the processor cannot be stopped at the reset vector using the hardware reset.

Device-specific software reset. This option is only available for some devices.

### Reset and halt after bootloader

Some devices have a ROM bootloader that executes before the processor jumps to your application code. Use this reset strategy to let the bootloader code execute and to halt the processor at the entry of the application code.

Depending on the device, this reset strategy is implemented using the hardware, core, or system reset.

This option is only available for some devices.

### Reset and halt before bootloader

This reset strategy is complementary to the **Reset and halt after bootloader** strategy. Depending on the device, it is implemented using the hardware, core, or system reset.

This option is only available for some devices.

All of these strategies are available for both the JTAG and the SWD interface, and all strategies halt the CPU after the reset.

A software reset of the target does not change the settings of the target system—it only resets the program counter.

Normally, a C-SPY reset is a software reset only. If you use the **Hardware** option, C-SPY will generate an initial hardware reset when the debugger is started. This is performed once before download, and if the option **Use flash loader(s)** is selected, also once after flash download. See *Debugging code in flash*, page 65, and *Debugging code in RAM*, page 66.





Hardware resets can be a problem if the low-level setup of your application is not complete. If the low-level setup does not set up memory configuration and clocks, the application will not work after a hardware reset. To handle this in C-SPY, the setup macro function `execUserReset()` is suitable. For a similar example where `execUserPreload()` is used, see *Remapping memory*, page 63.

### Duration

The time in milliseconds that the hardware reset asserts the reset signal (line `nSRST/nRESET`) low to reset the device.

Some devices might require a longer reset signal than the default 200 ms.

This option applies to the hardware reset, and to those custom reset strategies that use the hardware reset.

### Delay after

The delay time, in milliseconds, after the reset signal has been de-asserted, before the debugger attempts to control the processor.

The processor might be kept internally in reset for some time after the external reset signal has been de-asserted, and thus inaccessible for the debugger.

This option applies to the hardware reset, and to those custom reset styles that use the hardware reset.

### Emulator

These options are used for identifying the debug probe to use.

#### Always prompt for probe selection

Makes C-SPY always ask you to confirm which probe to use, if more than one debug probe is connected to the host computer.

#### Serial no

Enter the serial number of the debug probe you are using.

### Log communication

Logs the communication between C-SPY and the target system to a file. To interpret the result, detailed knowledge of the interface is required.

## CMSIS-DAP — Interface

The **Interface** options specify the interface between CMSIS-DAP and the target system.

### Probe config

#### Auto

The CMSIS-DAP driver automatically identifies the target CPU. It uses the default probe configuration file, if there is one. This works best if there is only one CPU present.

#### From file

Specifies that the probe configuration file needs to be overridden, or that there are several target CPUs.

#### Explicit

Specify how to find the target CPU.

### Interface

Selects the communication interface between the debug probe and the target system. Choose between:

#### JTAG

Uses the JTAG interface.

#### SWD

Uses the SWD interface.

### Interface speed

Specifies the JTAG and SWD communication speed. Choose between:

#### Auto detect

Automatically uses the highest possible frequency for reliable operation.

**Adaptive**

Synchronizes the clock to the processor clock outside the core. Works only with Arm devices that have the RTCK JTAG signal available.

***n* MHz**

Sets the JTAG and SWD communication speed to the selected frequency.

If there are JTAG communication problems or problems in writing to target memory (for example during program download), these problems might be resolved if the speed is set to a lower frequency.

**Probe configuration file****Override default**

Specify a probe configuration file to be used instead of the default probe configuration file that comes with the product package.

**Select**

Specify how to find the target CPU.

**Explicit probe configuration****Multi-target debug system**

Specifies that the debug system consists of more than one CPU.

**Target number (TAP or Multidrop ID)**

If the debug system is a multi-drop SWD, specify the Multidrop ID (in hexadecimal notation) of the DAP where your CPU is located.

If the debug system is a JTAG scan chain, specify the Target number TAP (Test Access Port) position of the device you want to connect to. The TAP numbers start from zero. If there are several CPUs at the TAP position, you also need to specify the **CPU number on target**.

**Target with multiple CPUs**

Specifies that the target has several CPUs.

**CPU number on target**

If the debug system is a multicore SWD, specify the CPU number on the DAP.

If the debug system is a JTAG scan chain and there are several CPUs at the TAP position, specify the CPU number on the TAP.

## E2 — Setup

The **Setup** options control the E2/E2Lite interface.

The screenshot shows a 'Setup' dialog box with the following elements:

- Target power:** A checkbox labeled 'From the probe' is checked.
- Emulator:** A label 'Serial no:' is followed by an empty text input field.
- ID code (hex):** A text input field containing the hexadecimal string '0xFFFFFFFFFFFFFFFFFFFFFFFFFFFFFFFF'.
- Log communication:** An unchecked checkbox is followed by a text input field containing '\$PROJ\_DIR\$\cspycomm.log' and a browse button '...'.

### Target power

Select **From the probe** to specify that the supply voltage to your target device will be supplied by the probe.

### Emulator

If more than one debug probe is connected to the host computer, use the **Serial no** option to select the correct one.

### ID code (hex)

The hexadecimal ID code protects certain devices with an authentication check before the debug session is started. If an incorrect ID code is entered, a connection error will occur.

For more information, see the hardware manual for your device.

### Log communication

Logs the communication between C-SPY and the target system to a file. To interpret the result, detailed knowledge of the interface is required.

## GDB Server

The **GDB Server** options control the C-SPY GDB Server for the STR9-comStick evaluation board.

### TCP/IP address or hostname

Specify the IP address and port number of a GDB server—by default the port number 3333 is used. The TCP/IP connection is used for connecting to a J-Link server running on a remote computer.

### Log communication

Logs the communication between C-SPY and the target system to a file. To interpret the result, detailed knowledge of the interface is required.

## G+LINK — Setup

The **Setup** options specify the G+LINK interface.

## Log communication

Logs the communication between C-SPY and the target system to a file. To interpret the result, detailed knowledge of the interface is required.

## I-jet — Setup

The **Setup** options control the I-jet and I-jet Trace in-circuit debugging probes.

## Reset

Selects the reset strategy to be used when the debugger starts. Note that Cortex-M uses a different set of strategies than other devices. Based on your hardware, one of the strategies is the default. Choose between:

### Disabled (no reset)

No reset is performed.

### Software

Sets `PC` to the program entry address and `SP` to the initial stack pointer value. This is a software reset.

### Hardware

The probe toggles the `nSRST/nRESET` line on the JTAG connector to reset the device. This reset usually also resets the peripheral units. The reset pulse timing is controlled by the **Duration** and **Delay after** options.

The processor should stop at the reset handler before executing any instruction. Some processors might not stop at the reset vector, but will be halted soon after, executing some instructions.

### Core

Resets the core via the `VECTRESET` bit—the peripheral units are not affected. For Cortex-M devices only.

**System**

Resets the core and peripheral units by setting the `SYSRESETREQ` bit in the `AIRCR` register. Reset vector catch is used for stopping the CPU at the reset vector before the first instruction is executed. For Cortex-M devices only.

**Connect during reset**

I-jet connects to the target while keeping Reset active. Reset is pulled low and remains low while connecting to the target. This is the recommended reset strategy for STM32 devices.

**Custom**

Device-specific hardware reset. Some devices might require a special reset procedure or timing to enable debugging, or to bring the processor to a halt before it has executed any instruction.

A watchdog timer might be disabled.

Special debug modes, such as debugging in power-saving modes, might be turned on.

This option is only available for some devices.

**Reset by watchdog or reset register**

Resets the processor using a software reset register or a watchdog reset. Peripheral units might not be reset.

This reset strategy is recommended when the processor cannot be stopped at the reset vector using the hardware reset.

Device-specific software reset. This option is only available for some devices.

**Reset and halt after bootloader**

Some devices have a ROM bootloader that executes before the processor jumps to your application code. Use this reset strategy to let the bootloader code execute and to halt the processor at the entry of the application code.

Depending on the device, this reset strategy is implemented using the hardware, core, or system reset.

This option is only available for some devices.

All of these strategies are available for both the JTAG and the SWD interface, and all strategies halt the CPU after the reset.

A software reset of the target does not change the settings of the target system—it only resets the program counter and the mode register CPSR to its reset state. For some Arm9, Arm11, and Cortex-A devices, it also resets the CP15 system control

coprocessor, effectively disabling the virtual memory (MMU), caches and memory protection.

Normally, a C-SPY reset is a software reset only. If you use the **Hardware** option, C-SPY will generate an initial hardware reset when the debugger is started. This is performed once before download, and if the option **Use flash loader(s)** is selected, also once after flash download. See *Debugging code in flash*, page 65, and *Debugging code in RAM*, page 66.



Hardware resets can be a problem if the low-level setup of your application is not complete. If the low-level setup does not set up memory configuration and clocks, the application will not work after a hardware reset. To handle this in C-SPY, the setup macro function `execUserReset()` is suitable. For a similar example where `execUserPreload()` is used, see *Remapping memory*, page 63.

### Duration

The time in milliseconds that the hardware reset asserts the reset signal (line `nSRST/nRESET`) low to reset the device.

Some devices might require a longer reset signal than the default 200 ms.

This option applies to the hardware reset, and to those custom reset strategies that use the hardware reset.

### Delay after

The delay time, in milliseconds, after the reset signal has been de-asserted, before the debugger attempts to control the processor.

The processor might be kept internally in reset for some time after the external reset signal has been de-asserted, and thus inaccessible for the debugger.

This option applies to the hardware reset, and to those custom reset styles that use the hardware reset.

### Target power

If power for the target system is supplied from the probe, this option specifies the status of the power supply after debugging. Choose between:

#### Leave on after debugging

Continues to supply power to the target even after the debug session has been stopped.

#### Switch off after debugging

Turns off the power to the target when the debug session stops.



## Emulator

These options are used for identifying the debug probe to use.

### Always prompt for probe selection

Makes C-SPY always ask you to confirm which probe to use, if more than one debug probe is connected to the host computer.

### Serial no

Enter the serial number of the debug probe you are using.

## Log communication

Logs the communication between C-SPY and the target system to a file. To interpret the result, detailed knowledge of the interface is required.

## I-jet — Interface

The **Interface** options specify the interface between I-jet or I-jet Trace and the target system.

## Probe config

### Auto

The I-jet driver automatically identifies the target CPU. It uses the default probe configuration file, if there is one. This works best if there is only one CPU present.

### From file

Specifies that the probe configuration file needs to be overridden, or that there are several target CPUs.

### Explicit

Specify how to find the target CPU.

## Interface

Selects the communication interface between the debug probe and the target system. Choose between:

### JTAG

Uses the JTAG interface.

### SWD

Uses the SWO interface, which uses fewer pins than JTAG. Select SWD if you want to use the serial-wire output (SWO) communication channel. Note that if you select **stdout/stderr via SWO** on the **General Options>Library Configuration** page, SWD is selected automatically. For more information about SWO settings, see *SWO Trace Window Settings dialog box*, page 223.

### cJTAG

Uses the cJTAG interface.

## Interface speed

Specifies the JTAG and SWD communication speed. Choose between:

### Auto detect

Automatically uses the highest possible frequency for reliable operation.

### Adaptive

Synchronizes the clock to the processor clock outside the core. Works only with Arm devices that have the `RTCK` JTAG signal available.

### *n* MHz

If there are JTAG communication problems or problems in writing to target memory (for example during program download), these problems might be resolved if the speed is set to a lower frequency.

## Probe configuration file

### Override default

Specify a probe configuration file to be used instead of the default probe configuration file that comes with the product package.

### Select

Specify how to find the target CPU.

## Explicit probe configuration

### Multi-target debug system

Specifies that the debug system consists of more than one CPU.

**Target number (TAP or Multidrop ID)**

If the debug system is a multi-drop SWD, specify the Multidrop ID (in hexadecimal notation) of the DAP where your CPU is located.

If the debug system is a JTAG scan chain, specify the Target number TAP (Test Access Port) position of the device you want to connect to. The TAP numbers start from zero and are counted from the TDO end (TAP number 0 is the one connected to the TDO line). If there are several CPUs at the TAP position, you also need to specify the **CPU number on target**.

**Target with multiple CPUs**

Specifies that the target has several CPUs.

**CPU number on target**

If the debug system is a multicore SWD, specify the CPU number on the DAP.

If the debug system is a JTAG scan chain and there are several CPUs at the TAP position, specify the CPU number on the TAP.

**JTAG scan chain contains non-Arm devices**

Enables JTAG scan chains that mix Arm devices with other devices like, for example, FPGA.

**Preceding bits**

Specify the number of IR bits preceding the Arm core to connect to.

**I-jet — Trace**

The **Trace** options specify the trace behavior for I-jet.

Trace

**Trace data collection**  
 Mode: Auto  Allow ETB  
 Buffer limit: 100%

**SWO protocol**  
 Auto  
 Manchester  
 UART

CPU clock:  MHz  
 SWD prescaler: Auto  
 SWO on the TraceD0 pin

## Mode

Power measurement (either TrgPwr as provided by the probe or via I-scope) does not depend on a particular trace mode and is always possible (if the probe supports it).

The **Debug Log** window will include messages about the currently used trace mode. If a particular mode cannot be used, either due to probe or board/device limitations, trace will be disabled and a warning message will be displayed in the **Debug Log** window. This is how the support of a particular trace mode is checked:

- The probe must support the particular mode.
- The probe must support the particular mode on a specific core. For example, ETM on Arm9 is not supported by the I-jet Trace probe.
- The specific core must support the particular mode. For example, Cortex-M0 does not support SWO/ETM/ETB at all and Arm9 does not support SWO.
- The used adapter must support the specified mode. For example, ETM trace is not possible when the Arm20 adapter is used with I-jet Trace.
- The specific device must support the particular mode. For example, ETM trace is not possible on a Cortex-M3 without ETM, which cannot be detected until reading the on-chip TPIU configuration register.

The **Mode** option specifies the mechanism and interface for trace data collection. Choose between:

### Auto

Automatically selects the best possible mechanism and interface, depending on probe and board/device capabilities.

The basic modes are tried in probe-dependent order:

- I-jet—first SWO, then ETB (ETM is not supported).
- I-jet Trace—first ETM, then SWO, then ETB.

If none of these modes are available, trace will be disabled (as when **None** is selected). In **Auto** mode, more initial accesses to trace-related on-chip resources might be made. So, if you are using a specific probe and a specific mode, you might want to set the mode explicitly which will make C-SPY initialize/configure trace resources more efficiently.

### None

Disables trace. In this mode, C-SPY will not access any trace-related on-chip resources. You can use this mode when:

- You are experiencing connectivity problems. It might be easier to diagnose the reason for connectivity problems without the interference from initialization of trace resources.

- Trace might change some internal clocking and/or GPIO mux settings and as a result some applications might not work well with a specific trace mode.
- You want to exercise low-power modes. Internal on-chip trace logic and toggling trace pins will require some additional current and it might interfere with low-power measurements. In extreme cases, enabling clocks for trace/GPIO might prevent the CPU from actually entering low-power modes, because some clocks inside the CPU must be kept active.

### Serial (SWO)

Collects trace data through the serial (SWO) interface.

### Parallel (ETM)

Collects trace data through the parallel (ETM) interface.

### On-chip (ETB/MTB)

Collects trace data through the on-chip (ETB/MTB) interface.

## Allow ETB

Allows simultaneous on-chip (ETB) trace. This option is only available when **Mode** is **Serial (SWO)**.

## Buffer limit

Limits probe memory use. This option is only available if parallel (ETM) mode is used, either explicitly through **Parallel (ETM)** or implicitly through **Auto**.

Collected trace data is stored in probe memory.

Because reading and decoding large amounts of trace data takes time, it is possible to limit what portion of ETM memory will actually be read by C-SPY once trace data collection is stopped (either because the CPU stopped or because the buffer got full). Using the **Buffer limit** option limits the buffer use to a percentage of the total memory size. Using more probe memory yields more trace data, but will take longer to see results and use up more host memory. C-SPY will retrieve the most recent samples from the trace probe, and the rest of the collected trace data will be discarded.

There is no simple correlation between the number of raw ETM samples and the number of PC samples visible in the **ETM Trace** window. The ETM protocol itself is highly compressed, and the probe provides additional compression of ETM idle cycles, so it is not possible to guess how many instructions can be decoded from a certain number of raw ETM samples collected by the trace probe. If your application changes PC a lot, ETM will need to use more samples to send more PC bits and as such, trace data will not compress well. For a particular application profile, this number is usually constant (between 0.5 and 2 instructions for a 4-bit sample), so you must use your own judgment

to see what buffer limit that provides a good balance between the size of decoded data and C-SPY performance.

### **SWO protocol**

Specifies the communication protocol for the SWO channel. Choose between:

#### **Auto**

Automatically selects the best possible protocol and speed, depending on the device you are using.

#### **Manchester**

Specifies the Manchester protocol.

#### **UART**

Specifies the UART protocol.

### **CPU clock**

Specifies the exact clock frequency used by the internal processor clock, `HCLK`, in MHz. The value can have decimals. This value is used for configuring the SWO communication speed and for calculating timestamps.

### **SWO prescaler**

Specifies the clock prescaler of the SWO communication channel in KHz. The prescaler, in turn, determines the SWO clock frequency.

**Auto** automatically uses the highest possible frequency that the I-jet or I-jet Trace debug probe can handle. Use this setting if data packets are lost during transmission.

To override the SWO clock setup options, use the **Override project default** option in the **SWO Configuration** dialog box, see *SWO Configuration dialog box*, page 225.

### **SWO on the TraceD0 pin**

Specifies that SWO trace data is output on the trace data D0 pin. When using this option, both the SWD and the JTAG interface can handle SWO trace data.

Note that both the device and the board you are using must support this pin.

## J-Link/J-Trace — Setup

The **Setup** options specify the J-Link/J-Trace probe.

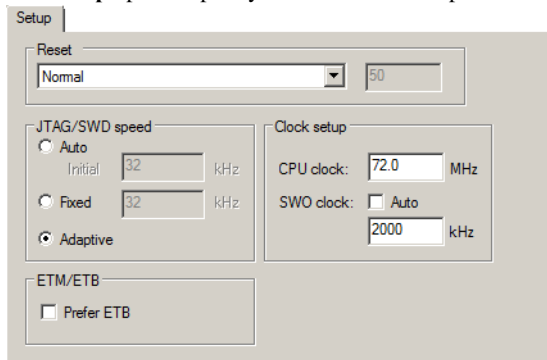

### Reset

Selects the reset strategy to be used when the debugger starts. Note that Cortex-M uses a different set of strategies than other devices. The actual reset strategy type number is specified for each available choice. Choose between:

#### Normal (0, default)

This is the default strategy. It does whatever is the best way to reset the target device, which for most devices is the same as the reset strategy **Core and peripherals (8)**. Some special handling might be needed for certain devices, for example devices which have a ROM bootloader that needs to run after reset and before your application is started.

#### Core (1)

Resets the core via the `VECTRESET` bit—the peripheral units are not affected.

#### Core and peripherals (8)

Resets the core and the peripherals.

#### Reset Pin (2)

J-Link pulls its `RESET` pin low to reset the core and the peripheral units. Normally, this causes the CPU `RESET` pin of the target device to go low as well, which results in a reset of both the CPU and the peripheral units.

#### Connect during reset (3)

J-Link connects to the target while keeping Reset active (reset is pulled low and remains low while connecting to the target). This is the recommended reset strategy for STM32 devices. This strategy is only available for STM32 devices.

### **Halt after bootloader (4 or 7)**

NXP Cortex-M0 devices. This is the same strategy as the **Normal** strategy, but the target is halted when the bootloader has finished executing. This is the recommended reset strategy for LPC11xx and LPC13xx devices.

Analog Devices Cortex-M3 devices (7), Resets the core and peripheral units by setting the `SYSRESETREQ` bit in the AIRCR. The core is allowed to perform the ADI kernel (which enables the debug interface) but the core is halted before the first instruction after the kernel is executed to guarantee that no user application code is performed after reset.

### **Halt before bootloader (5)**

This is the same strategy as the **Normal** strategy, but the target is halted before the bootloader has started executing. This strategy is normally not used, except in situations where the bootloader needs to be debugged. This strategy is only available for LPC11xx and LPC13xx devices.

### **Normal, disable watchdog (6, 9, or 10)**

First performs a Normal reset, to reset the core and peripheral units and halt the CPU immediately after reset. After the CPU is halted, the watchdog is disabled, because the watchdog is by default running after reset. If the target application does not feed the watchdog, J-Link loses connection to the device because it is permanently reset. This strategy is available for Freescale Kinetis devices (6), for NXP LPC 1200 devices (9), and for Samsung S3FN60D devices (10).

All of these strategies are available for both the JTAG and the SWD interface, and all strategies halt the CPU after the reset.

For other cores, choose between these strategies:

### **Hardware, halt after delay (ms) (0)**

Specify the delay between the hardware reset and the halt of the processor. This is used for making sure that the chip is in a fully operational state when C-SPY starts to access it. By default, the delay is set to zero to halt the processor as quickly as possible.

This is a hardware reset.

### **Hardware, halt using Breakpoint (1)**

After reset, J-Link continuously tries to halt the CPU using a breakpoint. Typically, this halts the CPU shortly after reset—in most systems, the CPU can execute some instructions before it is halted.

This is a hardware reset.



**Hardware, halt at 0 (4)**

Halts the processor by placing a breakpoint at the address zero. Note that this is not supported by all Arm microcontrollers.

This is a hardware reset.

**Hardware, halt using DBGRQ (5)**

After reset, J-Link continuously tries to halt the CPU using DBGRQ. Typically, this halts the CPU shortly after reset—in most systems, the CPU can execute some instructions before it is halted.

This is a hardware reset.

**Software (-)**

Sets PC to the program entry address.

This is a software reset.

**Software, Analog devices (2)**

Uses a reset sequence specific for the Analog Devices ADuC7xxx family. This strategy is only available if you have selected such a device from the **Device** drop-down list on the **General Options>Target** page.

This is a software reset.

**Hardware, NXP LPC (9)**

This strategy is only available if you have selected such a device from the **Device** drop-down list on the **General Options>Target** page.

This is a hardware reset specific to NXP LPC devices.

**Hardware, Atmel AT91SAM7 (8)**

This strategy is only available if you have selected such a device from the **Device** drop-down list on the **General Options>Target** page.

This is a hardware reset specific for the **Atmel AT91SAM7** family.

For more information about different reset strategies, see the *IAR J-Link and IAR J-Trace User Guide for JTAG Emulators for ARM Cores* available in the `arm\doc` directory.

A software reset of the target does not change the settings of the target system—it only resets the program counter and the mode register CPSR to its reset state. Normally, a C-SPY reset is a software reset only. If you use the Hardware reset option, C-SPY will generate an initial hardware reset when the debugger is started. This is performed once before download, and if the option **Use flash loader(s)** is selected, also once after flash download, see *Debugging code in flash*, page 65, and *Debugging code in RAM*, page 66.



Hardware resets can be a problem if the low-level setup of your application is not complete. If the low-level setup does not set up memory configuration and clocks, the application will not work after a hardware reset. To handle this in C-SPY, the setup macro function `execUserReset()` is suitable. For a similar example where `execUserPreload()` is used, see *Remapping memory*, page 63.

## JTAG/SWD speed

Specify the JTAG communication speed in kHz. Choose between:

### Auto

Automatically uses the highest possible frequency for reliable operation. The initial speed is the fixed frequency used until the highest possible frequency is found. The default initial frequency—1000 kHz—can normally be used, but in cases where it is necessary to halt the CPU after the initial reset, in as short time as possible, the initial frequency should be increased. If the CPU starts at a low clock speed, you might need to set a lower initial value, for example 32 kHz.

A high initial speed is necessary, for example, when the CPU starts to execute unwanted instructions—for example power down instructions—from flash or RAM after a reset. A high initial speed would in such cases ensure that the debugger can quickly halt the CPU after the reset.

The initial value must be in the range 1–50000 kHz.

### Fixed

Sets the JTAG communication speed in kHz. The value must be in the range 1–50000 kHz.

If there are JTAG communication problems or problems in writing to target memory (for example during program download), these problems might be resolved if the speed is set to a lower frequency.

### Adaptive

Synchronizes the clock to the processor clock outside the core. Works only with Arm devices that have the `RTCK` JTAG signal available. For information about adaptive speed, see the *J-Link/J-Trace User Guide* in the `arm\doc` directory.

## Clock setup

Specifies the CPU clock. Choose between:

### CPU clock

Specifies the exact clock frequency used by the internal processor clock, `HCLK`, in MHz. The value can have decimals. This value is used for configuring the SWO communication speed and for calculating timestamps.

### SWO clock

Specifies the clock frequency of the SWO communication channel in kHz.

#### Auto

Automatically uses the highest possible frequency that the debug probe can handle. If **Auto** is not selected, the wanted SWO clock value can be input in the text box. The value can have decimals. Use this option if data packets are lost during transmission.

To override the **Clock setup** options, use the **Override project default** option in the **SWO Configuration** dialog box, see *SWO Configuration dialog box*, page 225.

### ETM/ETB

The **Prefer ETB** option selects ETB trace instead of ETM trace, which is the default.

**Note:** This option only applies to J-Trace.

## J-Link/J-Trace — Connection

The **Connection** options specify the connection with the J-Link/J-Trace probe.

### Communication

Selects the communication channel between C-SPY and the J-Link debug probe. Choose between:

#### USB

Selects the USB connection. If **Serial number** is selected in the drop-down list, the J-Link debug probe with the specified serial number is chosen.

#### TCP/IP

Specify the IP address of a J-Link server. The TCP/IP connection is used for connecting to a J-Link server running on a remote computer.

**IP address**, specify the IP address of a J-Link probe connected to LAN.

**Auto detect**, automatically scans the network for J-Link probes. Use the dialog box to choose among the detected J-Link probes.

**Serial number**, connects to the J-Link probe on the network with the serial number that you specify.

## Interface

Selects the communication interface between the J-Link debug probe and the target system. Choose between:

### JTAG (default)

Uses the JTAG interface.

### SWD

Uses fewer pins than JTAG. Select **SWD** if you want to use the serial-wire output (SWO) communication channel. Note that if you select stdout/stderr via SWO on the **General Options>Library Configuration** page, **SWD** is selected automatically. For more information about SWO settings, see *SWO Trace Window Settings dialog box*, page 223.

## JTAG scan chain

Specifies the JTAG scan chain. Choose between:

### JTAG scan chain with multiple targets

Specifies that there is more than one device on the JTAG scan chain.

### TAP number

Specify the TAP (Test Access Port) position of the device you want to connect to. The TAP numbers start from zero.

### Scan chain contains non-Arm devices

Enables JTAG scan chains that mix Arm devices with other devices like, for example, FPGA.

### Preceding bits

Specify the number of IR bits before the Arm device to be debugged.

## Log communication

Logs the communication between C-SPY and the target system to a file. To interpret the result, detailed knowledge of the interface is required.

## Nu-Link — Setup

The **Setup** options specify the Nu-Link interface.

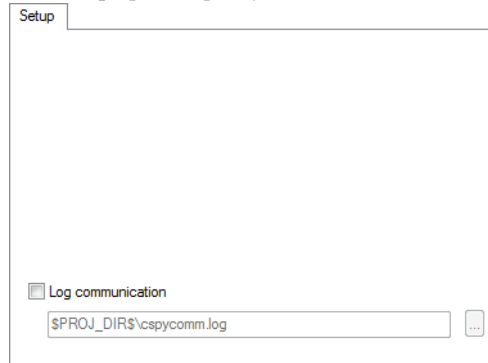

For information about this driver, see the file `NuMicro Cortex-M IAR ICE driver user manual.pdf` available in the `arm\bin\Nu-Link` directory.

### Log communication

Logs the communication between C-SPY and the target system to a file. To interpret the result, detailed knowledge of the interface is required.

## PE micro — Setup

The **Setup** options specify the PE micro interface.

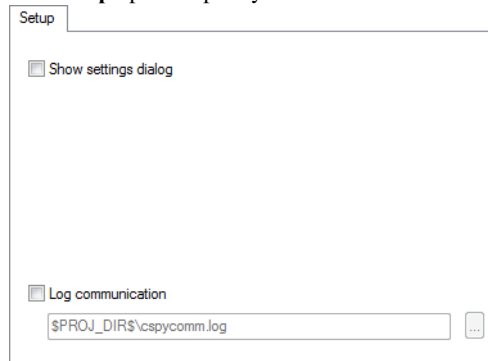

### Show settings dialog

Displays the **P&E Connection Manager** dialog box. For more information, see the file `PEMicroSettings.pdf`, available in the `arm\doc` directory.

## Log communication

Logs the communication between C-SPY and the target system to a file. To interpret the result, detailed knowledge of the interface is required.

## ST-LINK — Setup

The **Setup** options specify the ST-LINK interface.

## Emulator

Specify the emulator you are using. Choose between **Auto** (default) where the ST-LINK driver automatically selects the first emulator, or **ST-LINK/V1**, **ST-LINK/V2** or **ST-LINK/V3**.

### Serial no

If more than one debug probe is connected to the host computer, enter the serial number of the debug probe to identify the correct one.

### Always prompt for probe selection

Makes C-SPY always ask you to confirm which probe to use, if more than one debug probe is connected to the host computer.

**Reset**

Selects the reset strategy to be used when the debugger starts. The actual reset strategy type number is specified for each available choice. Choose between:

**System (0, default)**

Resets the core and peripheral units by setting the `SYSRESETREQ` bit in the `AIRCR` register. Reset vector catch is used for stopping the CPU at the reset vector before the first instruction is executed. Only available for Cortex-M devices.

**Hardware (1)**

The probe toggles the `nSRST/nRESET` line on the JTAG connector to reset the device. This reset usually also resets the peripheral units. Only available for ST-LINK version 2.

**Connect during reset (2)**

ST-LINK connects to the target while keeping the reset pin active (the reset pin is pulled low and remains low while connecting to the target). Only available for ST-LINK version 2 and when debugging Cortex-M devices.

**Core (3)**

Resets the core via the `VECTRESET` (Cortex-M) or `CWRR` (Cortex-A) bit—the peripheral units are not affected.

**Software reset (4)**

Sets the `PC` to program entry address and `SP` to the initial stack pointer value.

**Interface**

Selects the communication interface between the ST-LINK debug probe and the target system. Choose between:

**JTAG (default)**

Uses the JTAG interface.

**SWD**

Uses fewer pins than JTAG.

**Access port**

Use this option to specify the access port when using devices with more than one core—shared mode debugging. Choose between:

**Auto (default)**

A predefined value for the device is used. For most devices, the access port defaults to 0.

### Specify

For devices with more than one core, you can specify the number of the access port on the device you want to connect to, 0-3.

### Target power

Select **From the probe** to specify that the supply voltage to your target device will be supplied by the probe. Use **Target Vcc** to specify the voltage.

### Interface speed

Specify the JTAG and SWD communication speed. Choose between:

#### Default

Automatically uses the highest possible frequency for reliable operation. This is the only option for ST-LINK version 1.

#### *n* MHz

For ST-LINK version 2 and ST-LINK version 3, sets the JTAG and SWD communication speed to the selected frequency. This option is not available for ST-LINK version 1.

If the selected frequency is not supported by the specified probe, the closest and lowest supported frequency is automatically selected.

If there are JTAG communication problems or problems in writing to target memory (for example, during program download), these problems might be resolved if the speed is set to a lower frequency.



## ST-LINK — Communication

The **Communication** options specify the ST-LINK interface.

The screenshot shows a dialog box titled "Communication". It contains a "Clock setup" section with two rows: "CPU clock:" followed by a text box and "MHz", and "SWD clock:" followed by a radio button labeled "Auto" and a text box containing "2000" followed by "kHz". Below the "Clock setup" section is a checkbox labeled "Log communication" and a text box containing the path "\$PROJ\_DIR\$\cspycomm.log" with a browse button "..." to its right.

### Clock setup

Specifies the CPU clock. Choose between:

#### CPU clock

Specifies the exact clock frequency used by the internal processor clock, `HCLK`, in MHz. The value can have decimals. This value is used for configuring the SWO communication speed and for calculating timestamps.

#### SWO clock

Specifies the clock frequency of the SWO communication channel in kHz.

#### Auto

Automatically uses the highest possible frequency that the debug probe can handle. If **Auto** is not selected, the wanted SWO clock value can be input in the text box. The value can have decimals. Use this option if data packets are lost during transmission.

To override the **Clock setup** options, use the **Override project default** option in the **SWO Configuration** dialog box, see *SWO Configuration dialog box*, page 225.

### Log communication

Logs the communication between C-SPY and the target system to a file. To interpret the result, detailed knowledge of the interface is required.

## ST-LINK — Multicore

The **Multicore** options enable multicore and shared mode debugging for the ST-LINK interface.

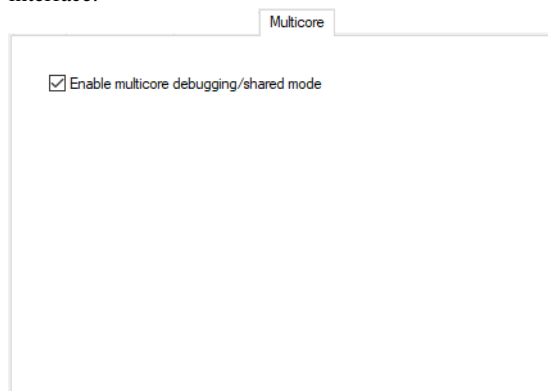

### Enable multicore debugging/shared mode

Enables multicore and shared mode debugging where two or more instances of IAR Embedded Workbench or an external tool share the same debug probe. Each instance accesses one core on the target device.

Multicore and shared mode debugging requires that you have installed the ST-LINK server. To install the server, run

```
arm\drivers\ST-LINK\st-stlink-server.1.0.6-1.msi.
```

See also, the option **Access Port** at *ST-LINK — Setup*, page 618.

For more information, see the application note from ST Microelectronics, *STM32H7x5/x7 dual-core microcontroller debugging* at [st.com](http://st.com).

## TI MSP-FET — Setup

The **Setup** options specify the TI MSP-FET interface.

### Connection

Controls the communication between C-SPY and the target device.

The C-SPY TI MSP-FET debugger can communicate with the target device via a number of different debug probes. Select the probe you are using. If you select *Automatic*, the debugger will automatically connect to the correct port.

Some emulator drivers support multiple emulators connected to the same host computer. Each emulator requires its own instance of IAR Embedded Workbench and each instance must identify its emulator. To identify an emulator, click the browse button to display a list of all detected emulators. To identify a connection, click the port in the list and the Mode LED on the attached emulator will light up.

### Target VCC

Specify the voltage provided by the USB interface:

#### Override default

Overrides the default voltage. The default voltage is displayed in the **Target VCC** text box, when you deselect the **Override default** option.

#### Target VCC

Specify the voltage with one decimal's precision in the range 1.0-4.0 V. This option can only be used when your target device is powered by the debug probe.

#### Settling time

Specify a delay (in milliseconds) that will be used between switching on the target VCC and starting the identification of the Arm device.

## Reset

Selects the reset strategy to be used when the debugger starts.

### Normal (0)

This is the default strategy. It does whatever is the best way to reset the target device.

## Interface

Determines the debug interface to use:

### Auto

Selects the debug interface automatically.

### JTAG

Selects the JTAG interface.

### SWD

Selects the SWD interface. SWD uses fewer pins than JTAG.

## Interface speed

Sets the JTAG communication speed. Choose between **Fast**, **Medium**, and **Slow**.

## TI MSP-FET — Download

The **Download** options specify the TI MSP-FET interface.

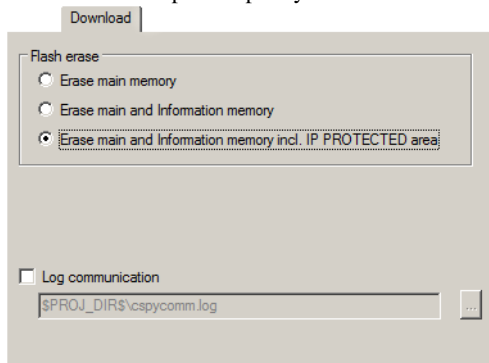

## Erase main memory

Erases only the main flash memory before download. The Information memory is not erased.

**Erase main and Information memory**

Erases both flash memories—main and Information memory—before download.

**Erase main and Information memory inc. IP PROTECTED area**

Erases the main and Information flash memories, including the IP protected area before download.

**Log communication**

Logs the communication between C-SPY and the target system to a file. To interpret the result, detailed knowledge of the interface is required.

**TI Stellaris — Setup**

The **Setup** options specify the TI Stellaris interface.

The screenshot shows the 'Setup' dialog box for TI Stellaris. It contains the following elements:

- Emulator**: A text box for 'Serial no:' and a checkbox for 'Always prompt for probe selection'.
- Reset**: A dropdown menu currently set to 'Software'.
- Interface**: Radio buttons for 'JTAG' and 'SWD', with 'SWD' selected.
- JTAG/SWD speed**: A text box containing '500' followed by 'kHz'.
- Log communication**: A checkbox and a text box containing '\$TOOLKIT\_DIRS\cspycomm.log' with a browse button.

**Emulator**

These options are used for identifying the debug probe to use.

**Always prompt for probe selection**

Makes C-SPY always ask you to confirm which probe to use, if more than one debug probe is connected to the host computer.

**Serial no**

Enter the serial number of the debug probe you are using.

## Reset

Selects the reset strategy to be used when the debugger starts. Based on your hardware, one of the strategies is the default. Choose between:

### Software (core) (0)

Resets the core. Sets `PC` to the program entry address and `SP` to the initial stack pointer value.

### System (1)

Resets the core and peripheral units. Sets `PC` to the program entry address and `SP` to the initial stack pointer value.

## Interface

Selects the communication interface between the TI Stellaris debug probe and the target system. Choose between:

### JTAG (default)

Uses the JTAG interface.

### SWD

Uses fewer pins than JTAG. Select SWD if you want to use the serial-wire output (SWO) communication channel. Note that if you select `stdout/stderr` via SWO on the **General Options>Library Configuration** page, SWD is selected automatically. For more information about SWO settings, see *SWO Trace Window Settings dialog box*, page 223.

## JTAG/SWD speed

Specify the JTAG communication speed in kHz.

## Log communication

Logs the communication between C-SPY and the target system to a file. To interpret the result, detailed knowledge of the interface is required.

## TI XDS — Setup

The **Setup** options control the TI XDS interface.

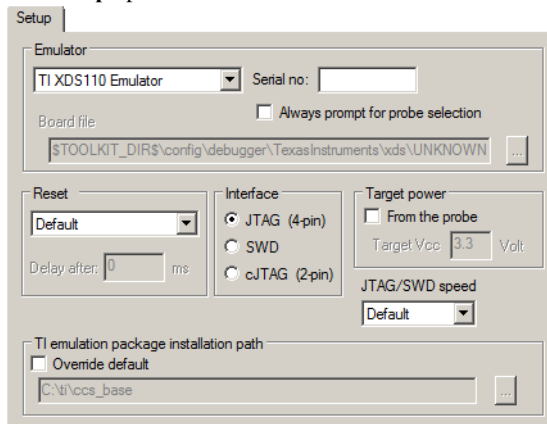

### Emulator

Specify the emulator you are using. If more than one debug probe is connected to the host computer, use the **Serial no** option to select the correct one.

To force the **Debug Probe Selection** dialog box to be displayed each time you start a debug session, use the option **Always prompt for probe selection**.

To override the default board file, first select the menu command **Specify custom board file** in the **Emulator** drop-down menu and then specify a board file using the **Board file** option.

### Reset

Selects the reset strategy to be used when the debugger starts. Based on your hardware, one of the strategies is the default. Choose between:

For Cortex-M devices:

#### CPU (0)

Resets the CPU.

#### System (1)

Resets the core and peripheral units.

#### Board (2)

Uses the reset pin to reset the device. Only available for CC26xx and CC13xx devices.

### **Board (3)**

Uses the reset pin to reset the device. Run and halt with delay. Available for all other Cortex-M devices.

For non-Cortex-M devices:

### **Software (0)**

Sets PC to the program entry address.

### **Hardware (1)**

Uses the reset pin to reset the device.

## **Interface**

Select the communication interface between the XDS debug probe and the target system.

## **Target power**

Select **From the probe** to specify that the supply voltage to your target device will be supplied by the probe. Use **Target Vcc** to specify the voltage.

This option is only available for the stand-alone TI XDS110 debug probe.

## **JTAG/SWD speed**

Specify the JTAG communication speed.

## **TI emulation package installation path**

Select **Override default** to override the default installation path of the Texas Instruments emulation package.



## TI XDS — Communication

The **Communication** options control the TI XDS interface.

### Clock setup

Specifies the CPU clock. Choose between:

#### CPU clock

Specifies the exact clock frequency used by the internal processor clock, `HCLK`, in MHz. The value can have decimals. This value is used for configuring the SWO communication speed and for calculating timestamps.

#### SWO clock

Specifies the clock frequency of the SWO communication channel in KHz.

#### Auto

Automatically uses the highest possible frequency that the debug probe can handle. If **Auto** is not selected, the wanted SWO clock value can be input in the text box. The value can have decimals. Use this option if data packets are lost during transmission.

To override the **Clock setup** options, use the **Override project default** option in the **SWO Configuration** dialog box, see *SWO Configuration dialog box*, page 225.

### COM port for SWO

Specifies the COM port to use for the SWO communication. Choose between:

#### Auto

The debugger automatically identifies the COM port that is associated with the debug probe.

### Specify

Specify the number of the COM port, 1-256.

### None

The debugger leaves the COM port unused and SWO trace is disabled.

### Log communication

Logs the communication between C-SPY and the target system to a file. To interpret the result, detailed knowledge of the interface is required.

## Third-Party Driver options

The **Third-Party Driver** options are used for loading any driver plugin provided by a third-party vendor. These drivers must be compatible with the C-SPY debugger driver specification.

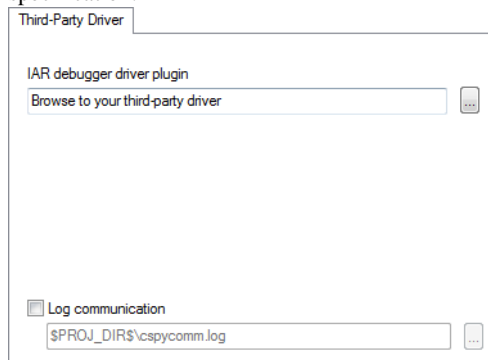

In addition to the options you can set here, you can set options for the third-party driver using the **Project>Options>Debugger>Extra Options** page.

### IAR debugger driver plugin

Specify the file path to the third-party driver plugin DLL file. A browse button is available for your convenience.

### Log communication

Logs the communication between C-SPY and the target system to a file. To interpret the result, detailed knowledge of the interface is required.

# Additional information on C-SPY drivers

This chapter describes the additional menus and features provided by the C-SPY® drivers. You will also find some useful hints about resolving problems.

---

## Reference information on C-SPY driver menus

This section gives reference information on the menus specific to the C-SPY drivers. More specifically, this means:

- *C-SPY driver*, page 631
- *Simulator menu (LAR native)*, page 632
- *Simulator menu (Imperas)*, page 634
- *CADI menu*, page 636
- *CMSIS-DAP menu*, page 637
- *E2 menu*, page 639
- *GDB Server menu*, page 640
- *G+LINK menu*, page 641
- *I-jet menu*, page 642
- *J-Link menu*, page 646
- *Nu-Link menu*, page 650
- *ST-Link menu*, page 650
- *TI MSP-FET menu*, page 653
- *TI Stellaris menu*, page 655
- *TI XDS menu*, page 656

### C-SPY driver

Before you start the C-SPY debugger, you must first specify a C-SPY driver in the **Options** dialog box, using the option **Debugger>Setup>Driver**.

When you start a debug session, a menu specific to that C-SPY driver will appear on the menu bar, with commands specific to the driver.

When we in this guide write “choose *C-SPY driver*>” followed by a menu command, *C-SPY driver* refers to the menu. If the feature is supported by the driver, the command will be on the menu.

## Simulator menu (IAR native)

The C-SPY simulator uses one of two debugger drivers. Which driver depends on which core or device you have selected for your application project, see *The IAR C-SPY Simulator*, page 48. When you use the IAR native simulator driver, this **Simulator** menu is added to the menu bar:

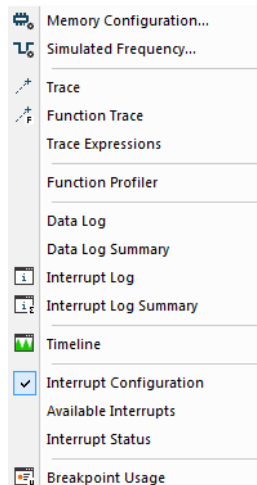

### Menu commands

These commands are available on the menu:



#### Memory Configuration

Displays a dialog box where you configure C-SPY to match the memory of your device, see *Memory Configuration dialog box for the C-SPY simulator*, page 196.



#### Trace

Opens a window which displays the collected trace data, see *Trace window*, page 229.



#### Function Trace

Opens a window which displays the trace data for function calls and function returns, see *Function Trace window*, page 238.

**Function Profiler**

Opens a window which shows timing information for the functions, see *Function Profiler window*, page 301.

**Data Log**

Opens a window which logs accesses to up to four different memory locations or areas, see *Data Log window*, page 266.

**Data Log Summary**

Opens a window which displays a summary of data accesses to specific memory location or areas, see *Data Log Summary window*, page 269.

**Interrupt Log**

Opens a window which displays the status of all defined interrupts, see *Interrupt Log window*, page 416.

**Interrupt Log Summary**

Opens a window which displays a summary of the status of all defined interrupts, see *Interrupt Log Summary window*, page 420.

**Timeline**

Opens a window which gives a graphical view of various kinds of information on a timeline, see *The application timeline*, page 257.

**Simulated Frequency**

Opens the **Simulated Frequency** dialog box where you can specify the simulator frequency used when the simulator displays time information, for example in the log windows. Note that this does not affect the speed of the simulator. For more information, see *Simulated Frequency dialog box*, page 635.

**Interrupt Configuration**

Opens a window where you can configure C-SPY interrupt simulation, see *Interrupt Configuration window*, page 410.

**Available Interrupts**

Opens a window with an overview of all available interrupts. You can also force an interrupt instantly from this window, see *Available Interrupts window*, page 413.

**Interrupt Status**

Opens a window from where you can instantly trigger an interrupt, see *Interrupt Status window*, page 414.



### Breakpoint Usage

Displays a window which lists all active breakpoints, see *Breakpoint Usage window*, page 140.

## Simulator menu (Imperas)

The C-SPY simulator uses one of two debugger drivers. Which driver depends on which core or device you have selected for your application project, see *The IAR C-SPY Simulator*, page 48. When you use the Imperas simulator driver, this **Simulator** menu is added to the menu bar:

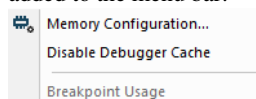

### Menu commands

These commands are available on the menu:

#### Memory Configuration

Displays a dialog box, see *Memory Configuration dialog box for the C-SPY simulator*, page 196.

#### Disable Debugger Cache

Disables memory caching and memory range checking in C-SPY.

Normally, C-SPY uses the memory range information in the **Memory Configuration** dialog box both to restrict access to certain parts of target memory and to cache target memory contents for improved C-SPY performance. Under certain rare circumstances, this is not appropriate, and you can choose **Disable Debugger Cache** to turn off the caching and memory range checking completely. All accesses from C-SPY will then result in corresponding accesses to the target system. Some of those circumstances are:

- When memory is remapped at runtime and cannot be specified as a fixed set of ranges.
- When the memory range setup is incorrect or incomplete.

#### Breakpoint Usage

Opens a window which lists all active breakpoints, see *Breakpoint Usage window*, page 140.

---

## Reference information on the C-SPY simulator

This section gives additional reference information on the C-SPY simulator, and reference information not provided elsewhere in this documentation.

Reference information about:

- *Simulated Frequency dialog box*, page 635

### Simulated Frequency dialog box

The **Simulated Frequency** dialog box is available from the C-SPY driver menu.

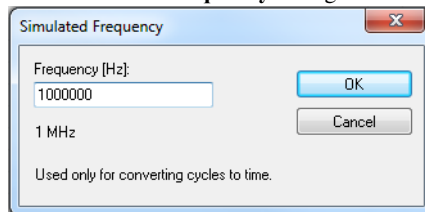

Use this dialog box to specify the simulator frequency used when the simulator displays time information.

#### Requirements

The C-SPY simulator. Not available for all cores and devices.

#### Frequency

Specify the frequency in Hz.

---

## Reference information on the C-SPY hardware debugger drivers

This section gives additional reference information on the C-SPY hardware debugger drivers, reference information not provided elsewhere in this documentation.

Reference information about:

- *CADI menu*, page 636
- *CMSIS-DAP menu*, page 637
- *E2 menu*, page 639
- *GDB Server menu*, page 640
- *I-jet menu*, page 642
- *J-Link menu*, page 646

- *Nu-Link menu*, page 650
- *ST-Link menu*, page 650
- *TI MSP-FET menu*, page 653
- *TI Stellaris menu*, page 655
- *TI XDS menu*, page 656

## CADI menu

When you are using the C-SPY CADI driver, the **CADI** menu is added to the menu bar:

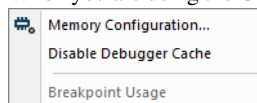

### Menu commands

These commands are available on the menu:

#### Memory Configuration

Displays a dialog box, see *Memory Configuration dialog box for C-SPY hardware debugger drivers*, page 200.

#### Disable Debugger Cache

Disables memory caching and memory range checking in C-SPY.

Normally, C-SPY uses the memory range information in the **Memory Configuration** dialog box both to restrict access to certain parts of target memory and to cache target memory contents for improved C-SPY performance. Under certain rare circumstances, this is not appropriate, and you can choose **Disable Debugger Cache** to turn off the caching and memory range checking completely. All accesses from C-SPY will then result in corresponding accesses to the target system. Some of those circumstances are:

- When memory is remapped at runtime and cannot be specified as a fixed set of ranges.
- When the memory range setup is incorrect or incomplete.

#### Breakpoint Usage

Opens a window which lists all active breakpoints, see *Breakpoint Usage window*, page 140.



## CMSIS-DAP menu

When you are using the C-SPY CMSIS-DAP driver, the **CMSIS-DAP** menu is added to the menu bar.

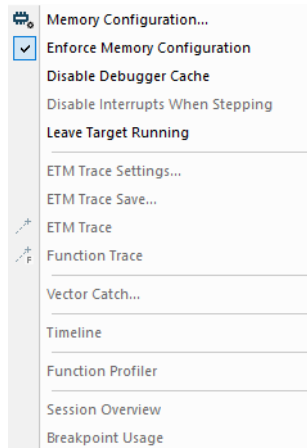

### Menu commands

These commands are available on the menu:

#### Memory Configuration

Displays a dialog box, see *Memory Configuration dialog box for C-SPY hardware debugger drivers*, page 200.

#### Enforce Memory Configuration

Prevents the driver from accessing any memory ranges in the zone `Memory` that have not been defined in the **Memory Configuration** dialog box.

#### Disable Debugger Cache

Disables memory caching and memory range checking in C-SPY.

Normally, C-SPY uses the memory range information in the **Memory Configuration** dialog box both to restrict access to certain parts of target memory and to cache target memory contents for improved C-SPY performance. Under certain rare circumstances, this is not appropriate, and you can choose **Disable Debugger Cache** to turn off the caching and memory range checking completely. All accesses from C-SPY will then result in corresponding accesses to the target system. Some of those circumstances are:

- When memory is remapped at runtime and cannot be specified as a fixed set of ranges.
- When the memory range setup is incorrect or incomplete.

### **Disable Interrupts When Stepping**

Ensures that only the stepped statements will be executed. Interrupts will not be executed. This command can be used when not running at full speed and some interrupts interfere with the debugging process.

### **Leave Target Running**

Leaves the application running on the target hardware after the debug session is closed.

Because existing breakpoints might not be automatically removed, consider disabling all breakpoints before using this menu command.

### **ETM Trace Settings**

Displays a dialog box, see *ETM Trace Settings dialog box (I-jet)*, page 219.

### **ETM Trace Save**

Displays a dialog box, see *Trace Save dialog box*, page 256.

### **ETM Trace**

Opens the ETM Trace window, see *Trace window*, page 229.

### **Function Trace**

Opens a window, see *Function Trace window*, page 238.

### **Vector Catch**

Displays a dialog box for setting a breakpoint directly on a vector in the interrupt vector table, see *Vector Catch dialog box*, page 157. Note that this command is not available for all Arm cores.

### **Timeline**

Opens a window, see *The application timeline*, page 257.

This menu command is only available when the SWD/SWO interface is used.

### **Function Profiler**

Opens a window which shows timing information for the functions, see *Function Profiler window*, page 301.

### **Session Overview**

Displays a window that lists information about the debug session, such as details about project settings, session settings, and the session state. To save the contents of the window to a file, choose **Save As** from the context menu.

### **Breakpoint Usage**

Opens a window which lists all active breakpoints, see *Breakpoint Usage window*, page 140.

## E2 menu

When you are using the C-SPY E2/E2Lite driver, the **E2** menu is added to the menu bar.

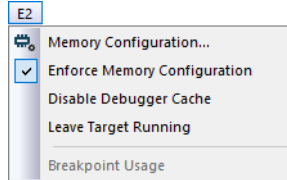

### Menu commands

These commands are available on the menu:

#### Memory Configuration

Displays a dialog box, see *Memory Configuration dialog box for C-SPY hardware debugger drivers*, page 200.

#### Enforce Memory Configuration

Prevents the driver from accessing any memory ranges in the zone *Memory* that have not been defined in the **Memory Configuration** dialog box.

#### Disable Debugger Cache

Disables memory caching and memory range checking in C-SPY.

Normally, C-SPY uses the memory range information in the **Memory Configuration** dialog box both to restrict access to certain parts of target memory and to cache target memory contents for improved C-SPY performance. Under certain rare circumstances, this is not appropriate, and you can choose **Disable Debugger Cache** to turn off the caching and memory range checking completely. All accesses from C-SPY will then result in corresponding accesses to the target system. Some of those circumstances are:

- When memory is remapped at runtime and cannot be specified as a fixed set of ranges.
- When the memory range setup is incorrect or incomplete.

#### Leave Target Running

Leaves the application running on the target hardware after the debug session is closed.

Because existing breakpoints might not be automatically removed, consider disabling all breakpoints before using this menu command.

#### Breakpoint Usage

Opens a window which lists all active breakpoints, see *Breakpoint Usage window*, page 140.

## GDB Server menu

When you are using the C-SPY GDB Server driver, the **GDB Server** menu is added to the menu bar.

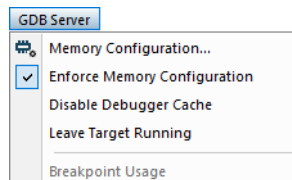

### Menu commands

These commands are available on the menu:

#### Memory Configuration

Displays a dialog box, see *Memory Configuration dialog box for C-SPY hardware debugger drivers*, page 200.

#### Enforce Memory Configuration

Prevents the driver from accessing any memory ranges in the zone `Memory` that have not been defined in the **Memory Configuration** dialog box.

#### Disable Debugger Cache

Disables memory caching and memory range checking in C-SPY.

Normally, C-SPY uses the memory range information in the **Memory Configuration** dialog box both to restrict access to certain parts of target memory and to cache target memory contents for improved C-SPY performance. Under certain rare circumstances, this is not appropriate, and you can choose **Disable Debugger Cache** to turn off the caching and memory range checking completely. All accesses from C-SPY will then result in corresponding accesses to the target system. Some of those circumstances are:

- When memory is remapped at runtime and cannot be specified as a fixed set of ranges.
- When the memory range setup is incorrect or incomplete.

#### Leave Target Running

Leaves the application running on the target hardware after the debug session is closed.

Because existing breakpoints might not be automatically removed, consider disabling all breakpoints before using this menu command.

### Breakpoint Usage

Opens a window which lists all active breakpoints, see *Breakpoint Usage window*, page 140.

## G+LINK menu

When you are using the C-SPY G+LINK driver, the **G+LINK** menu is added to the menu bar:

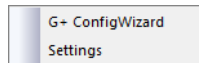

For information about G+LINK, see the file `G+ IAR EWARM ICE Driver Pack.pdf`, available in the `arm\bin\G+LinkPro` directory.

## I-jet menu

When you are using the C-SPY I-jet driver, the **I-jet** menu is added to the menu bar.

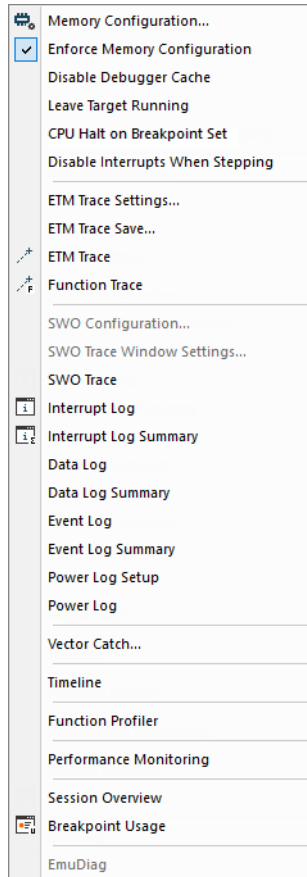

### Menu commands

These commands are available on the menu:

#### Memory Configuration

Displays a dialog box, see *Memory Configuration dialog box for C-SPY hardware debugger drivers*, page 200.

### Enforce Memory Configuration

Prevents the driver from accessing any memory ranges in the zone *Memory* that have not been defined in the **Memory Configuration** dialog box.

### Disable Debugger Cache

Disables memory caching and memory range checking in C-SPY.

Normally, C-SPY uses the memory range information in the **Memory Configuration** dialog box both to restrict access to certain parts of target memory and to cache target memory contents for improved C-SPY performance. Under certain rare circumstances, this is not appropriate, and you can choose **Disable Debugger Cache** to turn off the caching and memory range checking completely. All accesses from C-SPY will then result in corresponding accesses to the target system. Some of those circumstances are:

- When memory is remapped at runtime and cannot be specified as a fixed set of ranges.
- When the memory range setup is incorrect or incomplete.

### Leave Target Running

Leaves the application running on the target hardware after the debug session is closed.

Because existing breakpoints might not be automatically removed, consider disabling all breakpoints before using this menu command.

### CPU Halt on Breakpoint Set

Makes it possible to set a breakpoint in an executing application on hardware that does not support setting breakpoints while running. Setting a breakpoint halts the core, sets the breakpoint, and starts the core again.

### Disable Interrupts When Stepping

Ensures that only the stepped statements will be executed. Interrupts will not be executed. This command can be used when not running at full speed and some interrupts interfere with the debugging process.

### ETM Trace Settings

Displays a dialog box, see *ETM Trace Settings dialog box (I-jet)*, page 219.

### ETM Trace Save

Displays a dialog box, see *Trace Save dialog box*, page 256.

### ETM Trace

Opens the **ETM Trace** window, see *Trace window*, page 229.

### **Function Trace**

Opens the **Function Trace** window, see *Function Trace window*, page 238.

### **SWO Configuration**

Displays a dialog box, see *SWO Configuration dialog box*, page 225.

This menu command is only available when the SWD/SWO interface is used.

### **SWO Trace Window Settings**

Displays a dialog box, see *SWO Trace Window Settings dialog box*, page 223.

### **SWO Trace**

Opens the **SWO Trace** window to display the collected trace data, see *Trace window*, page 229.

This menu command is only available when the SWD/SWO interface is used.

### **Interrupt Log**

Opens a window, see *Interrupt Log window*, page 416.

This menu command is only available when the SWD/SWO interface is used.

### **Interrupt Log Summary**

Opens a window, see *Interrupt Log Summary window*, page 420.

This menu command is only available when the SWD/SWO interface is used.

### **Data Log**

Opens a window, see *Data Log window*, page 266.

This menu command is only available when the SWD/SWO interface is used.

### **Data Log Summary**

Opens a window, see *Data Log Summary window*, page 269.

This menu command is only available when the SWD/SWO interface is used.

### **Event Log**

Opens a window, see *Event Log window*, page 271.

### **Event Log Summary**

Opens a window, see *Event Log Summary window*, page 274.

### **Power Log Setup**

Opens a window, see *Power Log Setup window*, page 331.

### **Power Log**

Opens a window, see *Power Log window*, page 334.



**Vector Catch**

Displays a dialog box for setting a breakpoint directly on a vector in the interrupt vector table, see *Vector Catch dialog box*, page 157. Note that this command is not available for all Arm cores.

**Timeline**

Opens a window, see *Reference information on application timeline*, page 265.

This menu command is only available when the SWD/SWO interface is used.

**Function Profiler**

Opens a window which shows timing information for the functions, see *Function Profiler window*, page 301.

**Performance Monitoring**

Opens a window which shows event counters or CPU clock cycles through the Performance Monitoring Unit (PMU), see *Performance Monitoring window*, page 316.

**Session Overview**

Displays a window that lists information about the debug session, such as details about project settings, session settings, and the session state. To save the contents of the window to a file, choose **Save As** from the context menu.

**Breakpoint Usage**

Opens a window which lists all active breakpoints, see *Breakpoint Usage window*, page 140.

**EmuDiag**

Starts the **EmuDiag** application where you can diagnose the connection between the host computer, the probe, and the board.

## J-Link menu

When you are using the C-SPY J-Link driver, the **J-Link** menu is added to the menu bar.

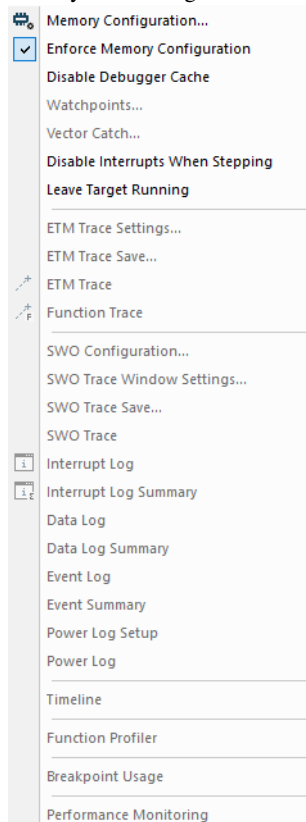

### Menu commands

These commands are available on the menu:

#### Memory Configuration

Displays a dialog box, see *Memory Configuration dialog box for C-SPY hardware debugger drivers*, page 200.

#### Enforce Memory Configuration

Prevents the driver from accessing any memory ranges in the zone `Memory` that have not been defined in the **Memory Configuration** dialog box.

**Disable Debugger Cache**

Disables memory caching and memory range checking in C-SPY.

Normally, C-SPY uses the memory range information in the **Memory Configuration** dialog box both to restrict access to certain parts of target memory and to cache target memory contents for improved C-SPY performance. Under certain rare circumstances, this is not appropriate, and you can choose **Disable Debugger Cache** to turn off the caching and memory range checking completely. All accesses from C-SPY will then result in corresponding accesses to the target system. Some of those circumstances are:

- When memory is remapped at runtime and cannot be specified as a fixed set of ranges.
- When the memory range setup is incorrect or incomplete.

**Watchpoints**

Displays a dialog box for setting watchpoints, see *Code breakpoints dialog box*, page 141.

**Vector Catch**

Displays a dialog box for setting a breakpoint directly on a vector in the interrupt vector table, see *Vector Catch dialog box*, page 157. Note that this command is not available for all Arm cores.

**Disable Interrupts When Stepping**

Ensures that only the stepped statements will be executed. Interrupts will not be executed. This command can be used when not running at full speed and some interrupts interfere with the debugging process.

**Leave Target Running**

Leaves the application running on the target hardware after the debug session is closed.

Because existing breakpoints might not be automatically removed, consider disabling all breakpoints before using this menu command.

**ETM Trace Settings**

Displays a dialog box to configure ETM trace data generation and collection, see *ETM Trace Settings dialog box (J-Link/J-Trace)*, page 221.

This menu command is only available when using either ETM or J-Link with ETB.

**ETM Trace Save**

Displays a dialog box to save the collected trace data to a file, see *Trace Save dialog box*, page 256.

This menu command is only available when using either ETM or J-Link with ETB.

#### **ETM Trace**

Opens the **ETM Trace** window to display the collected trace data, see *Trace window*, page 229.

This menu command is only available when using either ETM or J-Link with ETB.

#### **Function Trace**

Opens a window which displays the trace data for function calls and function returns, see *Function Trace window*, page 238.

This menu command is only available when using either ETM or J-Link with ETB.

#### **SWO Configuration**

Displays a dialog box, see *SWO Configuration dialog box*, page 225.

This menu command is only available when the SWD/SWO interface is used.

#### **SWO Trace Window Settings**

Displays a dialog box, see *SWO Trace Window Settings dialog box*, page 223.

This menu command is only available when the SWD/SWO interface is used.

#### **SWO Trace Save**

Displays a dialog box to save the collected trace data to a file, see *Trace Save dialog box*, page 256.

This menu command is only available when the SWD/SWO interface is used.

#### **SWO Trace**

Opens the **SWO Trace** window to display the collected trace data, see *Trace window*, page 229.

This menu command is only available when the SWD/SWO interface is used.

#### **Interrupt Log**

Opens a window, see *Interrupt Log window*, page 416.

This menu command is only available when the SWD/SWO interface is used.

#### **Interrupt Log Summary**

Opens a window, see *Interrupt Log Summary window*, page 420.

This menu command is only available when the SWD/SWO interface is used.

**Data Log**

Opens a window, see *Data Log window*, page 266.

This menu command is only available when the SWD/SWO interface is used.

**Data Log Summary**

Opens a window, see *Data Log Summary window*, page 269.

This menu command is only available when the SWD/SWO interface is used.

**Event Log**

Opens a window, see *Event Log window*, page 271.

**Event Log Summary**

Opens a window, see *Event Log Summary window*, page 274.

**Power Log Setup**

Opens a window, see *Power Log Setup window*, page 331.

**Power Log**

Opens a window, see *Power Log window*, page 334.

**Timeline**

Opens a window, see *The application timeline*, page 257.

This menu command is available when using ETM or SWD/SWO.

**Function Profiler**

Opens a window which shows timing information for the functions, see *Function Profiler window*, page 301.

**Breakpoint Usage**

Opens a window which lists all active breakpoints, see *Breakpoint Usage window*, page 140.

**Performance Monitoring**

Opens a window which shows event counters or CPU clock cycles through the Performance Monitoring Unit (PMU), see *Performance Monitoring window*, page 316.

## Nu-Link menu

When you are using the C-SPY Nu-Link driver, the **Nu-Link** menu is added to the menu bar:

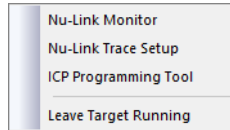

For information about the Nu-Link driver, contact Nuvoton Technology Corporation.

## ST-Link menu

When you are using the C-SPY ST-Link driver, the **ST-Link** menu is added to the menu bar.

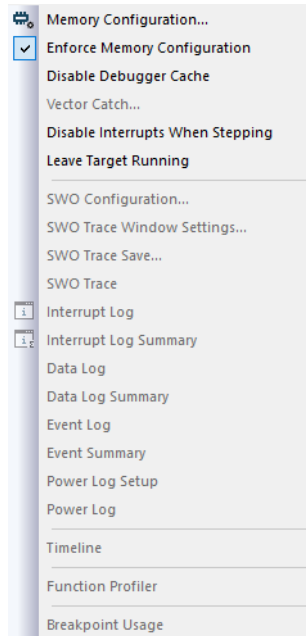

### Menu commands

These commands are available on the menu:

#### Memory Configuration

Displays a dialog box, see *Memory Configuration dialog box for C-SPY hardware debugger drivers*, page 200.

**Enforce Memory Configuration**

Prevents the driver from accessing any memory ranges in the zone *Memory* that have not been defined in the **Memory Configuration** dialog box.

**Disable Debugger Cache**

Disables memory caching and memory range checking in C-SPY.

Normally, C-SPY uses the memory range information in the **Memory Configuration** dialog box both to restrict access to certain parts of target memory and to cache target memory contents for improved C-SPY performance. Under certain rare circumstances, this is not appropriate, and you can choose **Disable Debugger Cache** to turn off the caching and memory range checking completely. All accesses from C-SPY will then result in corresponding accesses to the target system. Some of those circumstances are:

- When memory is remapped at runtime and cannot be specified as a fixed set of ranges.
- When the memory range setup is incorrect or incomplete.

**Vector Catch**

Opens a dialog box for setting a breakpoint directly on a vector in the interrupt vector table, see *Vector Catch dialog box*, page 157. Note that this command is not available for all Arm cores.

**Disable Interrupts When Stepping**

Ensures that only the stepped statements will be executed. Interrupts will not be executed. This command can be used when not running at full speed and some interrupts interfere with the debugging process.

**Leave Target Running**

Leaves the application running on the target hardware after the debug session is closed.

Because existing breakpoints might not be automatically removed, consider disabling all breakpoints before using this menu command.

**SWO Configuration<sup>1</sup>**

Displays a dialog box, see *SWO Configuration dialog box*, page 225.

**SWO Trace Window Settings<sup>1</sup>**

Displays a dialog box, see *SWO Trace Window Settings dialog box*, page 223.

**SWO Trace Save<sup>1</sup>**

Displays a dialog box to save the collected trace data to a file, see *Trace Save dialog box*, page 256.

### **SWO Trace<sup>1</sup>**

Opens the **SWO Trace** window to display the collected trace data, see *Trace window*, page 229.

### **Interrupt Log<sup>1</sup>**

Opens a window, see *Interrupt Log window*, page 416.

### **Interrupt Log Summary<sup>1</sup>**

Opens a window, see *Interrupt Log Summary window*, page 420.

### **Data Log<sup>1</sup>**

Opens a window, see *Data Log window*, page 266.

### **Data Log Summary<sup>1</sup>**

Opens a window, see *Data Log Summary window*, page 269.

### **Event Log**

Opens a window, see *Event Log window*, page 271.

### **Event Log Summary**

Opens a window, see *Event Log Summary window*, page 274.

### **Power Log Setup<sup>1</sup>**

Opens a window, see *Power Log Setup window*, page 331.

### **Power Log<sup>1</sup>**

Opens a window, see *Power Log window*, page 334.

### **Timeline<sup>2</sup>**

Opens a window, see *The application timeline*, page 257.

### **Function Profiler**

Opens a window which shows timing information for the functions, see *Function Profiler window*, page 301.

### **Breakpoint Usage**

Opens a window which lists all active breakpoints, see *Breakpoint Usage window*, page 140.

1 Only available when the SWD/SWO interface is used.

2 Available when using either ETM or SWD/SWO.



## TI MSP-FET menu

When you are using the C-SPY TI MSP-FET driver, the **TI MSP-FET** menu is added to the menu bar.

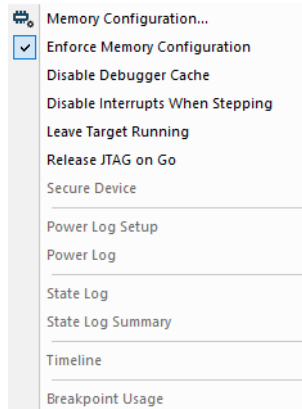

### Menu commands

These commands are available on the menu:

#### Memory Configuration

Displays a dialog box, see *Memory Configuration dialog box for C-SPY hardware debugger drivers*, page 200.

#### Enforce Memory Configuration

Prevents the driver from accessing any memory ranges in the zone `Memory` that have not been defined in the **Memory Configuration** dialog box.

#### Disable Debugger Cache

Disables memory caching and memory range checking in C-SPY.

Normally, C-SPY uses the memory range information in the **Memory Configuration** dialog box both to restrict access to certain parts of target memory and to cache target memory contents for improved C-SPY performance. Under certain rare circumstances, this is not appropriate, and you can choose **Disable Debugger Cache** to turn off the caching and memory range checking completely. All accesses from C-SPY will then result in corresponding accesses to the target system. Some of those circumstances are:

- When memory is remapped at runtime and cannot be specified as a fixed set of ranges.
- When the memory range setup is incorrect or incomplete.

### **Disable Interrupts When Stepping**

Ensures that only the stepped statements will be executed. Interrupts will not be executed. This command can be used when not running at full speed and some interrupts interfere with the debugging process.

### **Leave Target Running**

Leaves the application running on the target hardware after the debug session is closed.

### **Release JTAG on Go**

Sets the JTAG drivers in tri-state so that the device is released from JTAG control when the **Go** button is activated.



### **Secure Device**

Activates the flash memory protection lock. After this command has been executed, you must terminate the debug session and then reconnect the power to make it take effect.

### **Power Log Setup**

Opens a window, see *Power Log Setup window*, page 331.

### **Power Log**

Opens a window, see *Power Log window*, page 334.

### **State Log**

Opens a window, see *State Log window*, page 339.

### **State Log Summary**

Opens a window, see *State Log Summary window*, page 341.

### **Timeline**

Opens a window, see *The application timeline*, page 257.

### **Breakpoint Usage**

Opens a window which lists all active breakpoints, see *Breakpoint Usage window*, page 140.

## TI Stellaris menu

When you are using the C-SPY TI Stellaris driver, the **TI Stellaris** menu is added to the menu bar.

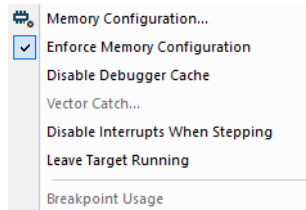

### Menu commands

These commands are available on the menu:

#### Memory Configuration

Displays a dialog box, see *Memory Configuration dialog box for C-SPY hardware debugger drivers*, page 200.

#### Enforce Memory Configuration

Prevents the driver from accessing any memory ranges in the zone `Memory` that have not been defined in the **Memory Configuration** dialog box.

#### Disable Debugger Cache

Disables memory caching and memory range checking in C-SPY.

Normally, C-SPY uses the memory range information in the **Memory Configuration** dialog box both to restrict access to certain parts of target memory and to cache target memory contents for improved C-SPY performance. Under certain rare circumstances, this is not appropriate, and you can choose **Disable Debugger Cache** to turn off the caching and memory range checking completely. All accesses from C-SPY will then result in corresponding accesses to the target system. Some of those circumstances are:

- When memory is remapped at runtime and cannot be specified as a fixed set of ranges.
- When the memory range setup is incorrect or incomplete.

#### Vector Catch

Opens a dialog box for setting a breakpoint directly on a vector in the interrupt vector table, see *Vector Catch dialog box*, page 157. Note that this command is not available for all Arm cores.

### Disable Interrupts When Stepping

Ensures that only the stepped statements will be executed. Interrupts will not be executed. This command can be used when not running at full speed and some interrupts interfere with the debugging process.

### Leave Target Running

Leaves the application running on the target hardware after the debug session is closed.

Because existing breakpoints might not be automatically removed, consider disabling all breakpoints before using this menu command.

### Breakpoint Usage

Opens a window which lists all active breakpoints, see *Breakpoint Usage window*, page 140.

## TI XDS menu

When you are using the C-SPY TI XDS driver, the **TI XDS** menu is added to the menu bar.

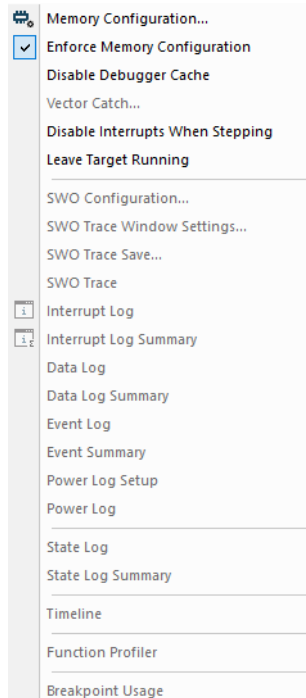

## Menu commands

These commands are available on the menu:

### Memory Configuration

Displays a dialog box, see *Memory Configuration dialog box for C-SPY hardware debugger drivers*, page 200.

### Enforce Memory Configuration

Prevents the driver from accessing any memory ranges in the zone `Memory` that have not been defined in the **Memory Configuration** dialog box.

### Disable Debugger Cache

Disables memory caching and memory range checking in C-SPY.

Normally, C-SPY uses the memory range information in the **Memory Configuration** dialog box both to restrict access to certain parts of target memory and to cache target memory contents for improved C-SPY performance. Under certain rare circumstances, this is not appropriate, and you can choose **Disable Debugger Cache** to turn off the caching and memory range checking completely. All accesses from C-SPY will then result in corresponding accesses to the target system. Some of those circumstances are:

- When memory is remapped at runtime and cannot be specified as a fixed set of ranges.
- When the memory range setup is incorrect or incomplete.

### Vector Catch

Opens a dialog box for setting a breakpoint directly on a vector in the interrupt vector table, see *Vector Catch dialog box*, page 157. Note that this command is not available for all Arm cores.

### Disable Interrupts When Stepping

Ensures that only the stepped statements will be executed. Interrupts will not be executed. This command can be used when not running at full speed and some interrupts interfere with the debugging process.

### Leave Target Running

Leaves the application running on the target hardware after the debug session is closed.

Because existing breakpoints might not be automatically removed, consider disabling all breakpoints before using this menu command.

### SWO Configuration

Displays a dialog box, see *SWO Configuration dialog box*, page 225.

### **SWO Trace Window Settings**

Displays a dialog box, see *SWO Trace Window Settings dialog box*, page 223.

### **SWO Trace Save**

Displays a dialog box to save the collected trace data to a file, see *Trace Save dialog box*, page 256.

### **SWO Trace**

Opens the **SWO Trace** window to display the collected trace data, see *Trace window*, page 229.

### **Interrupt Log**

Opens a window, see *Interrupt Log window*, page 416.

### **Interrupt Log Summary**

Opens a window, see *Interrupt Log Summary window*, page 420.

### **Data Log**

Opens a window, see *Data Log window*, page 266.

### **Data Log Summary**

Opens a window, see *Data Log Summary window*, page 269.

### **Event Log**

Opens a window, see *Event Log window*, page 271.

### **Event Log Summary**

Opens a window, see *Event Log Summary window*, page 274.

### **Power Log Setup**

Opens a window, see *Power Log Setup window*, page 331.

### **Power Log**

Opens a window, see *Power Log window*, page 334.

### **State Log**

Opens a window, see *State Log window*, page 339.

### **State Log Summary**

Opens a window, see *State Log Summary window*, page 341.

### **Timeline**

Opens a window, see *The application timeline*, page 257.

### **Function Profiler**

Opens a window which shows timing information for the functions, see *Function Profiler window*, page 301.

### Breakpoint Usage

Opens a window which lists all active breakpoints, see *Breakpoint Usage window*, page 140.

---

## Resolving problems

Debugging using the C-SPY hardware debugger systems requires interaction between many systems, independent from each other. For this reason, setting up this debug system can be a complex task. If something goes wrong, it might be difficult to locate the cause of the problem.

For information about the current debug session, choose **Session Overview** from the driver menu. Note that this window might not be supported by the C-SPY driver you are using.

This section includes suggestions for resolving the most common problems that can occur when debugging with the C-SPY hardware debugger systems.

For problems concerning the operation of the evaluation board, refer to the documentation supplied with it, or contact your hardware distributor.

### NO CONTACT WITH THE TARGET HARDWARE

There are several possible reasons for C-SPY to fail to establish contact with the target hardware. Do this:

- Check the communication devices on your host computer
- Verify that the cable is properly plugged in and not damaged or of the wrong type
- Make sure that the evaluation board is supplied with sufficient power
- Check that the correct options for communication have been specified in the IAR Embedded Workbench IDE.
- Check that the correct reset strategy is used.

Examine the linker configuration file to make sure that the application has not been linked to the wrong address.





# A

Abort (Report Assert option) . . . . . 95  
 \_\_abortLaunch (C-SPY system macro) . . . . . 448  
 absolute location, specifying for a breakpoint . . . . . 160  
 Access port (ST-LINK option) . . . . . 619  
 Access Type (Data breakpoints option) . . . . . 144  
 Access type (Edit Memory Access option) . . . . . 199  
 Access (Edit SFR option) . . . . . 195  
 accesses outside the bounds of arrays and other objects,  
   detecting . . . . . 361  
 Add Interrupt (Interrupt Configuration option) . . . . . 412  
 Address Bus Pattern (Address setting) . . . . . 144  
 Address Range (Find in Trace option) . . . . . 255  
 Address (Edit SFR option) . . . . . 195  
 Address (JTAG Watchpoints option) . . . . . 144  
 Advanced (multicore debugger option) . . . . . 589  
 Allow ETB (I-jet option) . . . . . 609  
 Ambiguous symbol (Resolve Symbol Ambiguity option) . . . . . 124  
 Any Size (Data setting) . . . . . 145  
 Any (Access Type setting) . . . . . 144  
 Any (Extern setting) . . . . . 145  
 Any (Mode setting) . . . . . 145  
 --application\_args (C-SPY command line option) . . . . . 527  
 application, built outside the IDE . . . . . 58  
 Apply authentication if status cannot be determined (multicore  
   debugger option) . . . . . 591  
 \_\_argCount (C-SPY system macro) . . . . . 444  
 assembler labels, viewing . . . . . 102  
 assembler source code, fine-tuning . . . . . 293  
 assembler symbols, in C-SPY expressions . . . . . 99  
 assembler variables, viewing . . . . . 102  
 assumptions, programming experience . . . . . 29  
 authentication of debugging . . . . . 63  
 Auto Scroll  
   (Timeline window context menu) . . . . . 279, 284, 288, 346, 424  
 Auto window . . . . . 104  
 Auto (Default breakpoint type setting) . . . . . 155  
 Auto (Probe config setting) . . . . . 598, 605

Autostep settings dialog box . . . . . 95  
 Available Interrupts window . . . . . 413

# B

--attach\_to\_running\_target  
   (C-SPY command line option) . . . . . 528  
 --backend (C-SPY command line option) . . . . . 528  
 backtrace information, viewing in Call Stack window . . . . . 88  
 batch mode, using C-SPY in . . . . . 515  
 --BE32 (C-SPY command line option) . . . . . 519  
 --BE8 (C-SPY command line option) . . . . . 519  
 Big Endian (Memory window context menu) . . . . . 175  
 bit loss or undefined behavior when shifting, detecting . . . . . 359  
 blocks, in C-SPY macros . . . . . 437  
 bold style, in this guide . . . . . 34  
 bounds of arrays and other objects, detect accesses  
   outside . . . . . 361  
 --bounds\_table\_size (linker option) . . . . . 380  
 Break Condition (JTAG Watchpoints option) . . . . . 143  
 breakpoint condition, example . . . . . 136–137  
 breakpoint dialog box  
   Code . . . . . 141  
   Data . . . . . 147  
   Data Log . . . . . 151  
   Immediate . . . . . 156  
   Log . . . . . 146  
   Trace Start Trigger . . . . . 239  
   Trace Stop Trigger . . . . . 240  
 Breakpoint type (Code breakpoints option) . . . . . 141  
 Breakpoint Usage window . . . . . 140  
 breakpoints  
   briefly about . . . . . 126  
   code, example . . . . . 486–487  
   connecting a C-SPY macro . . . . . 432  
   consumers of . . . . . 130  
   data . . . . . 147  
   data log . . . . . 151–152  
   description of . . . . . 126

disabling used by Stack window . . . . .	130	call stack information . . . . .	81
icons for in the IDE . . . . .	129	Call Stack window . . . . .	88
in Memory window . . . . .	133	for backtrace information. . . . .	81
listing all . . . . .	140	Call Stack (Timeline window context menu) . . . . .	279
reasons for using . . . . .	125	__cancelAllInterrupts (C-SPY system macro) . . . . .	449
setting . . . . .		__cancelInterrupt (C-SPY system macro). . . . .	449
in memory window . . . . .	133	Catch exceptions (Breakpoints option) . . . . .	155
using system macros . . . . .	134	Chain (Break Condition setting) . . . . .	144
using the dialog box . . . . .	132	checked heap, using . . . . .	351
single-stepping if not available . . . . .	56	Clear Group . . . . .	
toggling . . . . .	132	(Registers User Groups Setup window context menu) . . . . .	191
types of . . . . .	126	Clear trace data (Trace toolbar). . . . .	230
useful tips. . . . .	136	__clearBreak (C-SPY system macro) . . . . .	450
Breakpoints dialog box . . . . .		clock frequency, simulated . . . . .	635
Data Log (C-SPY hardware drivers) . . . . .	152	Clock setup (J-Link/J-Trace option) . . . . .	614
Trace Filter (I-jet) . . . . .	245	Clock setup (ST-LINK option) . . . . .	621
Trace Filter (J-Link). . . . .	251	Clock setup (TI XDS option) . . . . .	629
Trace Start (I-jet and CMSIS-DAP). . . . .	241	__closeFile (C-SPY system macro) . . . . .	450
Trace Start (J-Link/J-Trace). . . . .	246	CMSIS-DAP communication problem . . . . .	599
Trace Stop (I-jet and CMSIS-DAP). . . . .	243	CMSIS-DAP (C-SPY driver), menu . . . . .	637
Trace Stop (J-Link/J-Trace) . . . . .	249	code breakpoints . . . . .	
Breakpoints options (C-SPY options) . . . . .	154	overview . . . . .	126
Breakpoints window . . . . .	138	toggling . . . . .	132
Broadcast all branches (ETM Trace Settings option) . . . . .	222	code coverage . . . . .	
Browse (Trace toolbar) . . . . .	230	real-time. . . . .	84, 307
Buffer limit (I-jet Trace option) . . . . .	609	Code Coverage window . . . . .	308
byte order, setting in Memory window . . . . .	174	--code_coverage_file (C-SPY command line option) . . . . .	529
Byte (Data setting) . . . . .	145	code, covering execution of . . . . .	309
__bytes2Word16 (C-SPY system macro) . . . . .	444	COM port for SWO (TI XDS option) . . . . .	629
__bytes2Word32 (C-SPY system macro) . . . . .	444	command line options. . . . .	527
		typographic convention . . . . .	33
		command prompt icon, in this guide. . . . .	34
		communication problem . . . . .	
		CMSIS-DAP . . . . .	599
		I-jet . . . . .	606
		J-Link. . . . .	614
		ST-LINK . . . . .	620
		Communication (J-Link/J-Trace option). . . . .	615
		computer style (monospace font), typographic convention. . . . .	33
		conditional statements, in C-SPY macros . . . . .	437

## C

C function information, in C-SPY. . . . .	81
C symbols, in C-SPY expressions. . . . .	99
C variables, in C-SPY expressions . . . . .	99
Cache type (Edit Memory Range option) . . . . .	204
call chain, displaying in C-SPY . . . . .	81
Call Stack graph (Timeline window) . . . . .	277

- context menu, in windows . . . . . 102
- conventions, used in this guide . . . . . 33
- Copy Window Contents  
(Disassembly window context menu) . . . . . 87
- copyright notice . . . . . 2
- Core (Cores window) . . . . . 398
- cores
  - debugging multiple . . . . . 391
  - inspecting state of . . . . . 397
- Cores window . . . . . 397
- CPI (Generate setting) . . . . . 224
- cpu (C-SPY command line option) . . . . . 519
- CPU clock (I-jet Trace option) . . . . . 610
- CPU number on target  
(Explicit probe configuration setting) . . . . . 599, 607
- cspybat . . . . . 515
  - reading options from file (-f) . . . . . 547
- current position, in C-SPY Disassembly window . . . . . 84
- cursor, in C-SPY Disassembly window . . . . . 84
- Cycle accurate tracing (ETM Trace Settings option) . . . . . 222
- cycles (C-SPY command line option) . . . . . 529
- Cycles (Cores window) . . . . . 398
- C-RUN
  - creating rules for messages . . . . . 355
  - detecting various runtime errors . . . . . 355
  - getting started . . . . . 353
  - in non-interactive mode . . . . . 353
  - in the IDE . . . . . 351
  - requirements for . . . . . 352
  - setting options for . . . . . 373
  - using . . . . . 353
  - using the checked heap . . . . . 351
- C-RUN Messages Rules window . . . . . 378
- C-RUN Messages window . . . . . 376
- C-RUN runtime error checking . . . . . 349
- C-RUN runtime error checking, documentation . . . . . 32
- C-SPY
  - batch mode, using in . . . . . 515
  - debugger systems, overview of . . . . . 43
  - differences between drivers . . . . . 46
  - environment overview . . . . . 39
  - plugin modules, loading . . . . . 57
  - scripting. *See* macros
  - setting up . . . . . 56–57
  - starting the debugger . . . . . 58
- C-SPY drivers
  - overview . . . . . 45
  - specifying . . . . . 585
  - types of . . . . . 44
- C-SPY expressions . . . . . 98
  - evaluating, using Macro Quicklaunch window . . . . . 513
  - evaluating, using Quick Watch window . . . . . 118
  - in C-SPY macros . . . . . 436
  - Tooltip watch, using . . . . . 97
  - Watch window, using . . . . . 97
- C-SPY hardware debugger driver
  - extending functionality of . . . . . 63
- C-SPY hardware drivers, hardware installation . . . . . 50
- C-SPY macros
  - blocks . . . . . 437
  - conditional statements . . . . . 437
  - C-SPY expressions . . . . . 436
  - examples . . . . . 429
    - checking status of register . . . . . 432
    - creating a log macro . . . . . 433
    - execUserPreload, using . . . . . 63
    - remapping memory before download . . . . . 63
  - executing . . . . . 429
    - connecting to a breakpoint . . . . . 432
    - using Quick Watch . . . . . 432
    - using setup macro and setup file . . . . . 431
  - functions . . . . . 100, 434
  - keywords . . . . . 435–436, 438
  - loop statements . . . . . 437
  - macro statements . . . . . 436
  - parameters . . . . . 435
  - setup macro file . . . . . 428
  - executing . . . . . 431

setup macro functions	428
summary	439
system macros, summary of	444
using	427
variables	100, 435
C-SPY options	
Authentication	
Authentication (C-SPY options)	590
Extra Options	591
Images	587
Multicore	588
Plugins	592
Setup	585
C-SPYLink	45
C-STAT for static analysis, documentation for	32
C++ exceptions	
debugging	69–70
single stepping	76

## D

data breakpoints, overview	127
Data Bus Pattern (Data setting)	145
Data Coverage (Memory window context menu)	175
data coverage, in Memory window	173
data log breakpoints, overview	127
Data Log Events (SWO Configuration option)	226
Data Log graph (Timeline window)	282
Data Log Summary window	269
Data Log Summary (TI XDS menu)	658
Data Log window	266
Data Log (TI XDS menu)	658
Data Log (Timeline window context menu)	284
Data (JTAG Watchpoints option)	145
DCC (Debug Communications Channel)	90, 112
ddf (filename extension), selecting a file	57
debug authentication	63
Debug Log window	92
Debug menu (C-SPY main window)	68

Debug Probe Selection dialog box	51, 535–537
Debug (Report Assert option)	95
--debug_file (cspybat option)	531
debugger concepts, definitions of	42
debugger drivers	
<i>See</i> C-SPY drivers	45
simulator	48
Debugger Macros window	511
debugger system overview	43
debugging projects	
externally built applications	58
loading multiple images	59
debugging, RTOS awareness	41
--debug_auth_enforce (C-SPY command line option)	530
--debug_auth_settings (C-SPY command line option)	530
--debug_auth_type (C-SPY command line option)	531
--debug_heap (linker option)	381
Default breakpoint type (Breakpoints option)	155
default_no_bounds (pragma directive)	383
define_without_bounds (pragma directive)	383
define_with_bounds (pragma directive)	383
__delay (C-SPY system macro)	450
Delay after (CMSIS-DAP option)	597
Delay after (I-jet option)	604
Delay (Autostep Settings option)	96
Delete/revert All Custom SFRs (SFR Setup window context menu)	193
Device description file (debugger option)	585
device description files	57
definition of	61
modifying	61
specifying interrupts	478
Device Support Module	63
--device (C-SPY command line option)	532
--device_macro (C-SPY command line option)	532
Disable Debugger Cache (CADI menu)	634, 636
Disable Debugger Cache (CMSIS-DAP menu)	637
Disable Debugger Cache (GDB Server menu)	639–640
Disable Debugger Cache (I-jet menu)	643
Disable Debugger Cache (J-Link menu)	647

- Disable Debugger Cache (ST-Link menu) . . . . . 651
  - Disable Debugger Cache (TI MSP-FET menu). . . . . 653
  - Disable Debugger Cache (TI Stellaris menu) . . . . . 655
  - Disable Debugger Cache (TI XDS menu). . . . . 657
  - Disable Interrupts When Stepping (CMSIS-DAP menu) . 638
  - Disable Interrupts When Stepping (I-jet menu). . . . . 643
  - Disable Interrupts When Stepping (J-Link menu). . . . . 647
  - Disable Interrupts When Stepping (ST-Link menu) . . . . 651
  - Disable Interrupts When Stepping (TI MSP-FET menu) . 654
  - Disable Interrupts When Stepping (TI XDS menu). . . . . 657
  - `__disableInterrupts` (C-SPY system macro) . . . . . 451
  - `disable_check` (pragma directive) . . . . . 384
  - `--disable_interrupts` (C-SPY command line option) . . . . 532
  - Disassemble in Arm mode (Disassembly menu). . . . . 70
  - Disassemble in Arm64 mode (Disassembly menu). . . . . 71
  - Disassemble in Auto mode (Disassembly menu) . . . . . 71
  - Disassemble in Current processor mode  
(Disassembly menu) . . . . . 71
  - Disassemble in Thumb mode (Disassembly menu). . . . . 70
  - Disassembly menu (C-SPY main window). . . . . 70
  - Disassembly window . . . . . 83
    - context menu . . . . . 85, 398
  - disclaimer . . . . . 2
  - division by zero, detecting . . . . . 360
  - DLIB
    - consuming breakpoints . . . . . 130
    - naming convention. . . . . 34
  - do (macro statement) . . . . . 437
  - document conventions . . . . . 33
  - documentation
    - overview of guides. . . . . 31
    - overview of this guide . . . . . 30
    - this guide . . . . . 29
  - `--download_only` (C-SPY command line option) . . . . . 533
  - Driver (debugger option) . . . . . 585
  - `__driverType` (C-SPY system macro) . . . . . 451
  - `--drv_catch_exceptions` (C-SPY command line option) . . 533
  - `--drv_communication` (C-SPY command line option). . . 534
  - `--drv_communication_log` (C-SPY command line option) 538
  - `--drv_debugger_cache` (C-SPY command line option) . . 538
  - `--drv_default_breakpoint` (C-SPY command line option) . 539
  - `--drv_enforce_mem_config`  
(C-SPY command line option) . . . . . 540
  - `--drv_exclude_from_verify`  
(C-SPY command line option) . . . . . 540
  - `--drv_interface` (C-SPY command line option) . . . . . 541
  - `--drv_interface_speed` (C-SPY command line option) . . 542
  - `--drv_mem_ap` (C-SPY command line option) . . . . . 543
  - `--drv_reset_to_cpu_start` (C-SPY command line option) . 543
  - `--drv_restore_breakpoints` (C-SPY command line option) 544
  - `--drv_suppress_download` (C-SPY command line option) 519
  - `--drv_swo_clock_setup` (C-SPY command line option) . . 544
  - `--drv_trace_settings` (C-SPY command line option) . . . . 545
  - `--drv_vector_table_base` (C-SPY command line option). . 546
  - `--drv_verify_download` (C-SPY command line option) . . 519
  - Duration (CMSIS-DAP option) . . . . . 597
  - Duration (I-jet option). . . . . 604
- ## E
- Edit Breakpoint. . . . . 87
  - Edit Memory Range dialog box . . . . . 194
  - Edit Memory Range dialog box (C-SPY simulator) . . . . 198
  - Edit Memory Range dialog box  
(C-SPY hardware debugger drivers). . . . . 203
  - Edit Nickname (Debug Probe Selection dialog box). . . . . 51
  - Edit Settings (Trace toolbar). . . . . 230
  - edition, of this guide . . . . . 2
  - ELF entry point
    - disabling warning when 0x0 . . . . . 572
  - EmbeddedICE macrocell . . . . . 128
  - Emulator (TI XDS option) . . . . . 627
  - `__emulatorSpeed` (C-SPY system macro). . . . . 452
  - `__emulatorStatusCheckOnRead` (C-SPY system macro) . 453
  - Enable debug authentication (debugger option) . . . . . 590
  - Enable interrupt simulation  
(Interrupt Configuration option) . . . . . 412
  - Enable multicore debugging (ST-LINK option) . . . . . 622
  - Enable runtime checking (C-RUN option) . . . . . 374, 376
  - `__enableInterrupts` (C-SPY system macro) . . . . . 453

Enable/Disable Breakpoint (Disassembly window context menu) . . . . .	87
Enable/Disable (Trace toolbar) . . . . .	230
End address (Memory Save option) . . . . .	176
--endian (C-SPY command line option) . . . . .	519
endianness. <i>See</i> byte order	
Enforce Memory Configuration (CMSIS-DAP menu) . . . . .	637
Enforce Memory Configuration (GDB Server menu) . . . . .	639–640
Enforce Memory Configuration (I-jet menu) . . . . .	643
Enforce Memory Configuration (J-Link menu) . . . . .	646
Enforce Memory Configuration (ST-Link menu) . . . . .	651
Enforce Memory Configuration (TI MSP-FET menu) . . . . .	653
Enforce Memory Configuration (TI Stellaris menu) . . . . .	655
Enforce Memory Configuration (TI XDS menu) . . . . .	657
Enter Location dialog box. . . . .	159
Erase main and Information memory inc. IP PROTECTED area (TI MSP-FET option) . . . . .	625
Erase main and Information memory (TI MSP-FET option) . . . . .	625
Erase main memory (TI MSP-FET option) . . . . .	624
error checking (C-RUN), documentation . . . . .	32
ETB trace . . . . .	210
ETM trace . . . . .	210
ETM Trace Settings dialog box (I-jet) . . . . .	219
ETM/ETB (J-Link/J-Trace option) . . . . .	615
ETR trace . . . . .	210
__evaluate (C-SPY system macro) . . . . .	454
Evaluate Now (Macro Quicklaunch window context menu) . . . . .	514
Event Log Summary window . . . . .	274
Event Log window . . . . .	271
Event Log (Timeline window context menu) . . . . .	288
Events graph (Timeline window) . . . . .	286
examples	
C-SPY macros . . . . .	429
interrupts	
interrupt logging . . . . .	409
timer . . . . .	406
macros	
checking status of register . . . . .	432

creating a log macro . . . . .	433
using Quick Watch . . . . .	432
performing tasks and continue execution . . . . .	137
tracing incorrect function arguments . . . . .	136
EXC (Generate setting) . . . . .	224
Exception Viewer window . . . . .	93
execConfigureTraceETM (C-SPY setup macro) . . . . .	440
execConfigureTraceSWO (C-SPY setup macro) . . . . .	440
execUserAttach (C-SPY setup macro) . . . . .	441
execUserCoreConnect (C-SPY setup macro) . . . . .	444
execUserExecutionStarted (C-SPY setup macro) . . . . .	441
execUserExecutionStopped (C-SPY setup macro) . . . . .	441
execUserExit (C-SPY setup macro) . . . . .	443
execUserFlashExit (C-SPY setup macro) . . . . .	443
execUserFlashInit (C-SPY setup macro) . . . . .	442
execUserFlashReset (C-SPY setup macro) . . . . .	442
execUserPreload (C-SPY setup macro) . . . . .	441
execUserPreReset (C-SPY setup macro) . . . . .	443
execUserReset (C-SPY setup macro) . . . . .	443
execUserSetup (C-SPY setup macro) . . . . .	442
executed code, covering . . . . .	309
execution history, tracing . . . . .	217
execution mode . . . . .	45
Execution state (Cores window) . . . . .	397
__expandVar (C-SPY system macro) . . . . .	454
Explicit (Probe config setting) . . . . .	598, 605
expressions. <i>See</i> C-SPY expressions	
Extend to cover requested range (Trigger range setting) . . . . .	149, 153, 243, 245, 247, 250, 252
extended command line file, for cspybat . . . . .	547
Extern (JTAG Watchpoints option) . . . . .	145
Extra Options, for C-SPY . . . . .	591
E2 menu (C-SPY driver) . . . . .	639
E2 setup options . . . . .	600

## F

-f (cspybat option) . . . . .	547
Factory ranges (Memory Configuration option) . . . . .	201

Fast model platform . . . . . 594

File format (Memory Save option) . . . . . 176

file types

- device description, specifying in IDE . . . . . 57
- macro . . . . . 57, 585

filename extensions

- ddf, selecting device description file . . . . . 57
- mac, using macro file . . . . . 57

Filename (Memory Restore option) . . . . . 177

Filename (Memory Save option) . . . . . 177

Fill dialog box . . . . . 178

- \_\_fillMemory8 (C-SPY system macro) . . . . . 455
- \_\_fillMemory16 (C-SPY system macro) . . . . . 456
- \_\_fillMemory32 (C-SPY system macro) . . . . . 457
- \_\_fillMemory64 (C-SPY system macro) . . . . . 458

Find in Trace dialog box . . . . . 253

Find in Trace window . . . . . 255

Find in Trace (Disassembly window context menu) . . . . . 87

Find (Memory window context menu) . . . . . 175

Find (Trace toolbar) . . . . . 230

first activation time (interrupt property), definition of . . . . . 403

First activation (Interrupt Configuration option) . . . . . 411

Flash breakpoints dialog box . . . . . 158

Flash breakpoints, overview . . . . . 128

flash loader

- parameters to control . . . . . 580
- specifying relocation . . . . . 580
- specifying the path to . . . . . 580
- using . . . . . 575

Flash Loader Overview dialog box . . . . . 577

flash memory, load library module to . . . . . 473

- flash\_loader (C-SPY command line option) . . . . . 547
- \_\_fmessage (C-SPY macro keyword) . . . . . 438

Focus on Core (Cores window context menu) . . . . . 398

FOLD (Generate setting) . . . . . 224

for (macro statement) . . . . . 437

Force Interrupt

- (Available Interrupts window context menu) . . . . . 414

Force (SWO Trace Window Settings option) . . . . . 223

Forced Interrupts (Simulator menu) . . . . . 633

Format

- (Registers User Groups Setup window context menu) . . . 190
- fpu (C-SPY command line option) . . . . . 520
- From file (Probe config setting) . . . . . 598, 605
- From the probe (E2 setup option) . . . . . 600
- Function Profiler window . . . . . 301
- Function Profiler (I-jet menu) . . . . . 645
- Function Profiler (Simulator menu) . . . . . 633

function profiling

- real-time . . . . . 294

Function Trace window . . . . . 238

functions

- C-SPY running to when starting . . . . . 56, 585
- most time spent in, locating . . . . . 293
- function\_profiling (cspybat option) . . . . . 548

## G

GDB Server menu (C-SPY driver) . . . . . 640

- \_\_gdbserver\_exec\_command (C-SPY system macro) . . . 459
- gdbserv\_exec\_command (C-SPY command line option) 548

Generate (SWO Trace Window Settings option) . . . . . 224

- generate\_entries\_without\_bounds (compiler option) . . . 381
- generate\_entry\_\_without\_bounds (pragma directive) . . . 384
- \_\_getArg (C-SPY system macro) . . . . . 445
- \_\_getNumberOfCores (C-SPY system macro) . . . . . 459
- \_\_getSelectedCore (C-SPY system macro) . . . . . 459
- \_\_getTracePortSize (C-SPY system macro) . . . . . 460

Go To Source

- (Timeline window context menu) . . . 280, 285, 289, 347, 424

Go (Debug menu) . . . . . 79

G+LINK menu . . . . . 641

G+LINK, Setup options . . . . . 601

## H

Halfword (Data setting) . . . . . 145

hardware setup, power consumption because of . . . . . 327

Hardware (Default breakpoint type setting) . . . . . 155

__hasDAPRegs (C-SPY system macro) . . . . .	461
heap . . . . .	351
heap integrity violations, detecting . . . . .	370
heap memory leaks, detecting . . . . .	368
heap usage error, detecting . . . . .	367
highlighting, in C-SPY . . . . .	80
Hold time (Interrupt Configuration option). . . . .	411
hold time (interrupt property), definition of . . . . .	403
__hwJetResetWithStrategy (C-SPY system macro) . . . . .	461
__hwReset (C-SPY system macro) . . . . .	462
__hwResetRunToBp (C-SPY system macro) . . . . .	462
__hwResetWithStrategy (C-SPY system macro) . . . . .	464
__hwRunToBreakpoint (C-SPY system macro) . . . . .	464

## I

IAR debugger driver plugin (debugger option). . . . .	630
icons, in this guide . . . . .	34
ID code (E2 setup option). . . . .	600
if else (macro statement). . . . .	437
if (macro statement) . . . . .	437
Ignore (Report Assert option) . . . . .	95
--ignore_uninstrumented_pointers (compiler option) . . . . .	381
--ignore_uninstrumented_pointers (linker option). . . . .	382
Images window. . . . .	72
Images, loading multiple. . . . .	587
immediate breakpoints, overview . . . . .	127
implicit or explicit integer conversion, detecting . . . . .	355
Input Mode dialog box . . . . .	91
input, special characters in Terminal I/O window. . . . .	91
insert checks for (C-RUN option). . . . .	375
installation directory . . . . .	33
Instruction Profiling (Disassembly window context menu) . . . . .	86
integer conversion, detect implicit or explicit . . . . .	355
Intel-extended, C-SPY output format . . . . .	44
Interface speed . . . . .	598
Interface speed (I-jet option). . . . .	606
Interface speed (ST-LINK option) . . . . .	620
Interface (CMSIS-DAP option) . . . . .	598

Interface (I-jet option). . . . .	606
Interface (J-Link/J-Trace option) . . . . .	616
Interface (ST-LINK option) . . . . .	619
Interface (TI Stellaris option) . . . . .	626
Interface (TI XDS option). . . . .	628
interference, power consumption because of . . . . .	327
Interrupt Configuration window . . . . .	410
interrupt handling, power consumption during . . . . .	326
Interrupt Log graph in Timeline window . . . . .	422
Interrupt Log Summary window . . . . .	341, 420
Interrupt Log Summary (TI XDS menu). . . . .	658
Interrupt Log window . . . . .	416
Interrupt Log (TI XDS menu). . . . .	658
Interrupt Logs (Force setting). . . . .	224
Interrupt Status window . . . . .	414
interrupt system, using device description file . . . . .	405
interrupts	
adapting C-SPY system for target hardware . . . . .	405
simulated, introduction to . . . . .	401
timer, example . . . . .	406
using system macros . . . . .	404
Interrupts (Timeline window context menu). . . . .	424
__isBatchMode (C-SPY system macro) . . . . .	465
__isMacroSymbolDefined (C-SPY system macro). . . . .	466
italic style, in this guide . . . . .	33–34
ITM Log (Force setting). . . . .	224
ITM Stimulus Ports (SWO Configuration option) . . . . .	228
I-jet communication problem . . . . .	606
I-jet JTAG interface . . . . .	602
I-jet menu (C-SPY driver) . . . . .	642
I-jet Trace . . . . .	602

## J

--jet_board_cfg (C-SPY command line option) . . . . .	548
--jet_board_did (C-SPY command line option) . . . . .	549
--jet_cpu_clock (C-SPY command line option) . . . . .	550
--jet_disable_pmu (C-SPY command line option) . . . . .	550
--jet_disable_pmu_dap (C-SPY command line option). . . . .	551



- jet\_ir\_length (C-SPY command line option) . . . . . 551
  - jet\_power\_from\_probe (C-SPY command line option) . 551
  - jet\_probe (C-SPY command line option) . . . . . 552
  - jet\_script\_file (C-SPY command line option) . . . . . 552
  - jet\_standard\_reset (C-SPY command line option) . . . . 553
  - jet\_startup\_connection\_timeout  
(C-SPY command line option) . . . . . 554
  - jet\_swo\_on\_d0 (C-SPY command line option) . . . . . 555
  - jet\_swo\_prescaler (C-SPY command line option) . . . . 555
  - jet\_swo\_protocol (C-SPY command line option) . . . . 555
  - jet\_tap\_position (C-SPY command line option) . . . . . 556
  - \_\_jlinkExecCommand (C-SPY system macro) . . . . . 466
  - \_\_jlinkExecMacro (C-SPY system macro) . . . . . 467
  - jlink\_dcc\_timeout (C-SPY command line option) . . . . 556
  - jlink\_device\_select (C-SPY command line option) . . . 557
  - jlink\_exec\_command (C-SPY command line option) . 557
  - jlink\_initial\_speed (C-SPY command line option) . . . 558
  - jlink\_ir\_length (C-SPY command line option) . . . . . 558
  - jlink\_reset\_strategy (C-SPY command line option) . . . 559
  - jlink\_script\_file (C-SPY command line option) . . . . 559
  - jlink\_trace\_source (C-SPY command line option) . . . . 560
  - JTAG interfaces
    - I-jet . . . . . 602
    - J-Link . . . . . 611, 615
  - JTAG scan chain contains non-ARM devices  
(Explicit probe configuration setting) . . . . . 607
  - JTAG scan chain (CMSIS-DAP option) . . . . . 599
  - JTAG scan chain (I-jet option) . . . . . 606
  - JTAG scan chain (J-Link/J-Trace option) . . . . . 616
  - JTAG Watchpoints dialog box . . . . . 143
  - JTAG watchpoints, overview . . . . . 128
  - \_\_jtagCommand (C-SPY system macro) . . . . . 467
  - \_\_jtagCP15IsPresent (C-SPY system macro) . . . . . 468
  - \_\_jtagCP15ReadReg (C-SPY system macro) . . . . . 468
  - \_\_jtagCP15WriteReg (C-SPY system macro) . . . . . 468
  - \_\_jtagData (C-SPY system macro) . . . . . 469
  - \_\_jtagRawRead (C-SPY system macro) . . . . . 469
  - \_\_jtagRawSync (C-SPY system macro) . . . . . 470
  - \_\_jtagRawWrite (C-SPY system macro) . . . . . 471
  - \_\_jtagResetTRST (C-SPY system macro) . . . . . 472
  - JTAG/SWD speed (CMSIS-DAP option) . . . . . 598
  - JTAG/SWD speed (J-Link/J-Trace option) . . . . . 614
  - JTAG/SWD speed (TI Stellaris option) . . . . . 626
  - JTAG/SWD speed (TI XDS option) . . . . . 628
  - J-Link communication problem . . . . . 614
  - J-Link JTAG interface . . . . . 611, 615
  - J-Link menu (C-SPY driver) . . . . . 646
- ## L
- labels (assembler), viewing . . . . . 102
  - Leave Target Running (CMSIS-DAP menu) . . . . . 638
  - Leave Target Running (GDB Server menu) . . . . . 639–640
  - Leave Target Running (I-jet menu) . . . . . 643
  - Leave Target Running (J-Link menu) . . . . . 647
  - Leave Target Running (ST-Link menu) . . . . . 651
  - Leave Target Running (TI MSP-FET menu) . . . . . 654
  - Leave Target Running (TI Stellaris menu) . . . . . 656
  - Leave Target Running (TI XDS menu) . . . . . 657
  - leave\_target\_running (C-SPY command line option) . . 560
  - Length (Fill option) . . . . . 178
  - library functions
    - C-SPY support for using, plugin module . . . . . 565
  - lightbulb icon, in this guide . . . . . 34
  - Link condition (Trace Start option) . . . . . 248
  - Link condition (Trace Stop option) . . . . . 251, 253
  - linker options
    - typographic convention . . . . . 33
    - consuming breakpoints . . . . . 130
  - Little Endian (Memory window context menu) . . . . . 174
  - Live Watch window . . . . . 112
  - lmiiftdi\_reset\_strategy (C-SPY command line option) . . 561
  - \_\_loadImage (C-SPY system macro) . . . . . 472
  - loading multiple debug files, list currently loaded . . . . 72
  - loading multiple images . . . . . 59
  - Locals window . . . . . 106
  - log breakpoints, overview . . . . . 126
  - loop statements, in C-SPY macros . . . . . 437
  - low-power mode, power consumption during . . . . . 324

LSU (Generate setting) . . . . . 224

## M

mac (filename extension), using a macro file . . . . . 57  
--macro (C-SPY command line option) . . . . . 561  
macro files, specifying . . . . . 57, 585  
Macro Quicklaunch window . . . . . 513  
Macro Registration window . . . . . 509  
macro statements . . . . . 436  
macros  
    executing . . . . . 429  
    using . . . . . 427  
--macro-param (C-SPY command line option) . . . . . 562  
main function, C-SPY running to when starting . . . . . 56, 585  
\_\_makeString (C-SPY system macro) . . . . . 446  
--mapu (C-SPY command line option) . . . . . 562  
Mask (Address setting) . . . . . 144  
Mask (Data setting) . . . . . 145  
Mask (Match data setting) . . . . . 150, 242, 244, 248, 250, 253  
master project (multicore debugging) . . . . . 392  
Match data (Data breakpoints option) . . . . . 150  
Match data (Trace Start option) . . . . . 242, 244, 248  
Match data (Trace Stop option) . . . . . 250, 253  
Memory access checking (Memory Access Setup option) 197  
Memory Configuration dialog box (C-SPY simulator) . . . 196  
Memory Configuration dialog box  
(C-SPY hardware debugger drivers) . . . . . 200  
Memory Configuration (CADI menu) . . . . . 634, 636  
Memory Configuration (CMSIS-DAP menu) . . . . . 637  
Memory Configuration (GDB Server menu) . . . . . 639–640  
Memory Fill (Memory window context menu) . . . . . 175  
Memory Restore dialog box . . . . . 177  
Memory Restore (Memory window context menu) . . . . . 175  
Memory Save dialog box . . . . . 176  
Memory Save (Memory window context menu) . . . . . 175  
Memory window . . . . . 172  
memory zones . . . . . 165  
Memory (CADI option) . . . . . 594

\_\_memoryRestore (C-SPY system macro) . . . . . 473  
\_\_memorySave (C-SPY system macro) . . . . . 474  
menu bar, C-SPY-specific . . . . . 67  
\_\_message (C-SPY macro keyword) . . . . . 438  
\_\_messageBoxYesCancel (C-SPY system macro) . . . . . 475  
\_\_messageBoxYesNo (C-SPY system macro) . . . . . 476  
Messages window, amount of output . . . . . 92  
migration, from earlier IAR compilers . . . . . 32  
Mixed Mode (Disassembly window context menu) . . . . . 87  
Mode (JTAG Watchpoints option) . . . . . 145  
monospace font, meaning of in guide. *See* computer style  
Motorola, C-SPY output format . . . . . 44  
Move to PC (Disassembly window context menu) . . . . . 85  
--mspfet\_erase\_flash (C-SPY command line option) . . . . 562  
--mspfet\_interface\_speed (C-SPY command line option) . 563  
--mspfet\_reset\_strategy (C-SPY command line option) . . 563  
--mspfet\_settlingtime (C-SPY command line option) . . . 564  
--mspfet\_vccvoltage (C-SPY command line option) . . . . 564  
MTB trace . . . . . 210  
multicore debugging . . . . . 391  
    asymmetric multicore debugging . . . . . 392  
    session file . . . . . 399  
Multicore toolbar . . . . . 399  
Multicore (C-SPY options) . . . . . 588  
--multicore\_nr\_of\_cores (C-SPY command line option) . . 564  
Multi-target debug system (Explicit probe  
configuration setting) . . . . . 606  
Multi-target debug system  
(Explicit probe configuration setting) . . . . . 599

## N

Name or PID of server to connect to (CADI option) . . . . 594  
Name (Edit SFR option) . . . . . 194  
naming conventions . . . . . 34  
Navigate  
(Timeline window context menu) . . . 279, 283, 287, 345, 423  
Next Symbol (Symbolic Memory window context menu) 181  
Non User (Mode setting) . . . . . 145  
Normal (Break Condition setting) . . . . . 143

no\_arith\_checks (pragma directive) . . . . . 385  
no\_bounds (pragma directive) . . . . . 385  
Number of cores (debugger option) . . . . . 588  
Nu-Link . . . . . 46  
    Setup options . . . . . 617  
Nu-Link menu . . . . . 650

## O

OP Fetch (Access Type setting) . . . . . 144  
Open Setup Window (Timeline window context menu) . . 347  
\_\_openFile (C-SPY system macro) . . . . . 476  
Operation (Fill option) . . . . . 178  
operators, sizeof in C-SPY . . . . . 100  
optimizations, effects on variables . . . . . 101  
options  
    in the IDE . . . . . 583  
    on the command line . . . . . 527, 591  
Options (Stack window context menu) . . . . . 185  
\_\_orderInterrupt (C-SPY system macro) . . . . . 477  
Originator (debugger option) . . . . . 593  
overflow, signed or unsigned . . . . . 357  
Override default .board file (debugger option) . . . . . 587  
Override default (Probe configuration file setting) . . 599, 606  
Override project default (SWO Configuration option) . . 227  
overriding the default stack setup . . . . . 182

## P

-p (C-SPY command line option) . . . . . 565  
\_\_param (C-SPY macro keyword) . . . . . 436  
parameters  
    list of passed to the flash loader . . . . . 578  
    tracing incorrect values of . . . . . 81  
    typographic convention . . . . . 33  
part number, of this guide . . . . . 2  
partner project (multicore debugging) . . . . . 392  
PC samples (Force setting) . . . . . 224  
PC Sampling (SWO Configuration option) . . . . . 226

PC (Cores window) . . . . . 398  
#PC (symbol) in C-SPY macros . . . . . 99, 437  
#PC32 (symbol) in C-SPY macros . . . . . 99, 437  
#PC64 (symbol) in C-SPY macros . . . . . 99, 437  
Perform mass erase before flashing (debugger option) . . 587  
performance monitoring . . . . . 313  
    setting up . . . . . 315  
Performance Monitoring (I-jet menu) . . . . . 645  
peripheral units  
    debugging power consumption for . . . . . 321  
    detecting mistakenly unattended . . . . . 325  
    detecting unattended . . . . . 325  
    device-specific . . . . . 61  
    displayed in Registers window . . . . . 164  
    in an event-driven system . . . . . 326  
    in C-SPY expressions . . . . . 99  
    initializing using setup macros . . . . . 428  
peripheral units, in Register window . . . . . 164  
Please select one symbol  
    (Resolve Symbol Ambiguity option) . . . . . 124  
--plugin (C-SPY command line option) . . . . . 565  
plugin modules (C-SPY) . . . . . 44  
    loading . . . . . 57  
Plugins (C-SPY options) . . . . . 592  
\_\_popSimulatorInterruptExecutingStack  
    (C-SPY system macro) . . . . . 478  
pop-up menu. *See* context menu  
power consumption, measuring . . . . . 294, 321  
Power Log Setup window . . . . . 331  
Power Log window . . . . . 334  
Power Log (Timeline window context menu) . . . . . 346  
power sampling . . . . . 294  
Power Sampling (SWO Configuration option) . . . . . 229  
Preceding bits (JTAG scan chain setting) . . . . . 607  
prerequisites, programming experience . . . . . 29  
Previous Symbol  
    (Symbolic Memory window context menu) . . . . . 181  
probability (interrupt property) . . . . . 412  
    definition of . . . . . 403  
Probability % (Interrupt Configuration option) . . . . . 412

Probe config (CMSIS-DAP option) . . . . .	598
Probe config (I-jet option) . . . . .	605
Probe configuration file (CMSIS-DAP option) . . . . .	599
Probe configuration file (I-jet option) . . . . .	606
__probeType (C-SPY system macro) . . . . .	479
--proc_stack_XXX (C-SPY command line option) . . . . .	566
Profile Selection (Timeline window context menu) . . . . .	281, 347
profiling	
analyzing data . . . . .	296
on function level . . . . .	296
on instruction level . . . . .	298
profiling information, on functions and instructions . . . . .	293
profiling sources	
sampling . . . . .	294
trace (calls) . . . . .	294
trace (flat) . . . . .	294
program counter symbol, in C-SPY macros . . . . .	99, 437
program execution	
breaking . . . . .	126–127
in C-SPY . . . . .	75
multiple cores in C-SPY . . . . .	391
programming experience . . . . .	29
program. <i>See</i> application	
Progress bar (Trace toolbar) . . . . .	230
projects, for debugging externally built applications. . . . .	58
PTM trace . . . . .	210
publication date, of this guide . . . . .	2
P&E Micro . . . . .	46
Setup options . . . . .	617

## Q

Quick Watch window . . . . .	118
executing C-SPY macros . . . . .	432

## R

RAM (Edit Memory Access option) . . . . .	204
Range for (Viewing Range option) . . . . .	290

Range (Break Condition setting) . . . . .	144
Read (Access Type setting) . . . . .	144
__readAPReg (C-SPY system macro) . . . . .	480
__readDPReg (C-SPY system macro) . . . . .	480
__readFile (C-SPY system macro) . . . . .	481
__readFileByte (C-SPY system macro) . . . . .	481
reading guidelines . . . . .	29
__readMemoryBuffer (C-SPY system macro) . . . . .	447
__readMemoryByte (C-SPY system macro) . . . . .	482
__readMemory8 (C-SPY system macro) . . . . .	482
__readMemory16 (C-SPY system macro) . . . . .	482
__readMemory32 (C-SPY system macro) . . . . .	483
__readMemory64 (C-SPY system macro) . . . . .	483
reference information, typographic convention . . . . .	34
register groups . . . . .	164
predefined, enabling . . . . .	186
Register User Groups Setup window . . . . .	189
registered trademarks . . . . .	2
__registerMacroFile (C-SPY system macro) . . . . .	484
Registers window . . . . .	186
registers, displayed in Registers window . . . . .	186
Release JTAG on Go (TI MSP-FET menu) . . . . .	654
Removal All Groups	
(Registers User Groups Setup window context menu) . . . . .	191
Removal	
(Registers User Groups Setup window context menu) . . . . .	190
Remove All (Macro Quicklaunch window context menu) . . . . .	514
Remove (Macro Quicklaunch window context menu) . . . . .	514
Repeat interval (Interrupt Configuration option) . . . . .	411
repeat interval (interrupt property), definition of . . . . .	403
Replace (Memory window context menu) . . . . .	175
Report Assert dialog box . . . . .	94
reset vector, specifying location of . . . . .	546
Reset (CMSIS-DAP option) . . . . .	595
Reset (I-jet option) . . . . .	602
Reset (J-Link/J-Trace option) . . . . .	611
Reset (ST-Link option) . . . . .	619
Reset (TI Stellaris option) . . . . .	626
Reset (TI XDS option) . . . . .	627
__resetFile (C-SPY system macro) . . . . .	484

- reset\_style (C-SPY command line option) . . . . . 566
  - Resolve Source Ambiguity dialog box . . . . . 161
  - Restore software breakpoints at (Breakpoints option) . . . 155
  - Restore (Memory Restore option) . . . . . 177
  - \_\_restoreSoftwareBreakpoints (C-SPY system macro) . . . 484
  - return (macro statement) . . . . . 437
  - ROM-monitor, definition of . . . . . 44
  - ROM/Flash (Edit Memory Access option) . . . . . 205
  - RTOS awareness debugging . . . . . 41
  - RTOS awareness (C-SPY plugin module) . . . . . 42
  - Run to Cursor (Disassembly window context menu) . . . . 85
  - Run to Cursor, command for executing . . . . . 80
  - Run to (C-SPY option) . . . . . 56, 585
  - runtime checking, setting options for C-RUN . . . . . 373
  - runtime error checking . . . . . 349
    - getting started . . . . .
    - requirements for . . . . . 353
    - requirements for . . . . . 352
    - using C-RUN . . . . . 350
  - runtime error checking, documentation . . . . . 32
  - runtime\_checking (compiler option) . . . . . 382
  - Run/Step/Stop affect all cores  
(Cores window context menu) . . . . . 398
  - Run/Step/Stop affect current core only  
(Cores window context menu) . . . . . 398
  - R/W (Access Type setting) . . . . . 144
- ## S
- sampling, profiling source . . . . . 294
  - Save Custom SFRs (SFR Setup window context menu) . . 194
  - Save to File (Timeline window context menu) . . . . . 280
  - Save to File  
(Register User Groups Setup window context menu) . . . 191
  - Save (Memory Save option) . . . . . 177
  - Save (Trace toolbar) . . . . . 230
  - Scale (Viewing Range option) . . . . . 291
  - scripting C-SPY. *See* macros
  - sdm\_debug\_architecture (C-SPY command line option) 568
  - sdm\_library (C-SPY command line option) . . . . . 568
  - sdm\_library\_hint (C-SPY command line option) . . . . . 569
  - sdm\_manifest (C-SPY command line option) . . . . . 569
  - Secure Debug Manager . . . . . 63
  - Secure Debug Manager (debugger options) . . . . . 590
  - Secure Device (TI MSP-FET menu) . . . . . 654
  - Select Graphs  
(Timeline window context menu) . . . 281, 285, 289, 347, 425
  - Select plugins to load (debugger option) . . . . . 592
  - Select (Probe configuration file setting) . . . . . 599, 606
  - \_\_selectCore (C-SPY system macro) . . . . . 485
  - semihosting (C-SPY command line option) . . . . . 570
  - Serial no (E2 setup option) . . . . . 600
  - session file (multicore debugging) . . . . . 399
  - Session Overview (CMSIS-DAP menu) . . . . . 638
  - Session Overview (I-jet menu) . . . . . 645
  - Set Data Breakpoint (Memory window context menu) . . . 175
  - Set Data Log Breakpoint  
(Memory window context menu) . . . . . 176
  - Set Next Statement (Disassembly window context menu) . 87
  - \_\_setCodeBreak (C-SPY system macro) . . . . . 486
  - \_\_setDataBreak (C-SPY system macro) . . . . . 487
  - \_\_setDataLogBreak (C-SPY system macro) . . . . . 489
  - \_\_setLogBreak (C-SPY system macro) . . . . . 490
  - \_\_setSimBreak (C-SPY system macro) . . . . . 492
  - \_\_setTraceStartBreak (C-SPY system macro) . . . . . 493
  - \_\_setTraceStopBreak (C-SPY system macro) . . . . . 495
  - setup macro file, registering . . . . . 57
  - setup macro functions . . . . . 428
    - reserved names . . . . . 439
  - Setup macros (debugger option) . . . . . 585
  - Setup (C-SPY options) . . . . . 585
  - SFR
    - in Registers window . . . . . 187
    - using as assembler symbols . . . . . 99
  - SFR Setup window . . . . . 191
  - SFR/Uncached (Edit Memory Access option) . . . . . 205
  - shared mode debugging, ST-LINK . . . . . 619
  - shifting, detecting bit loss or undefined behavior . . . . 359
  - shortcut menu. *See* context menu
  - Show All (SFR Setup window context menu) . . . . . 193

Show Custom SFRs only (SFR Setup window context menu) . . . . .	193	stack.mac . . . . .	427
Show Factory SFRs only (SFR Setup window context menu) . . . . .	193	Stall processor on FIFO full (ETM Trace Settings option)	222
Show Numerical Value (Timeline window context menu) . . . . .	285, 289, 347	standard C, sizeof operator in C-SPY . . . . .	100
Show offsets (Stack window context menu) . . . . .	184	Start address (Fill option) . . . . .	178
Show timestamp (ETM Trace Settings option) . . . . .	222	Start address (Memory Save option) . . . . .	176
Show Timing (Timeline window context menu) . . . . .	280	Start Core (Cores window context menu) . . . . .	398
Show variables (Stack window context menu) . . . . .	184	State Log graph (Timeline window) . . . . .	344
signed or unsigned overflow, detecting . . . . .	357	State Log window . . . . .	339
--silent (C-SPY command line option) . . . . .	570	static analysis tool, documentation for . . . . .	32
Simple (multicore debugger option) . . . . .	588	Statics window . . . . .	115
Simulated Frequency dialog box . . . . .	635	Status (Cores window) . . . . .	398
simulating interrupts, enabling/disabling . . . . .	412	Step Into, description . . . . .	77
Simulator menu . . . . .	632, 634	Step Out, description . . . . .	78
simulator, introduction . . . . .	48	Step Over, description . . . . .	77
64-bit mode . . . . .		step points, definition of . . . . .	76
definition . . . . .	45	--stlink_reset_strategy (C-SPY command line option) . . . . .	571
Size (Edit SFR option) . . . . .	195	Stop Core (Cores window context menu) . . . . .	398
Size (Timeline window context menu) . . . . .	285, 289, 346–347	__strFind (C-SPY system macro) . . . . .	497
Size (Trace Filter option) . . . . .	252	ST-LINK communication problem . . . . .	620
Size (Trace Start option) . . . . .	243, 247	ST-LINK menu (C-SPY driver) . . . . .	650
Size (Trace Stop option) . . . . .	245, 249	__subString (C-SPY system macro) . . . . .	497
sizeof . . . . .	100	Suppress download (debugger option) . . . . .	586
slave. <i>See</i> partner		--suppress_entrypoint_warning (C-SPY command line option) . . . . .	572
SLEEP (Generate setting) . . . . .	224	SWD interface, information in Trace window . . . . .	213
Smart Analog . . . . .		switch, detect unhandled cases . . . . .	360
displaying collected data . . . . .	286	SWO communication channel . . . . .	
__smessage (C-SPY macro keyword) . . . . .	438	enabling . . . . .	541, 606, 616, 626
--sockets (C-SPY command line option) . . . . .	571	for timestamps in trace . . . . .	223
software delay, power consumption during . . . . .	324	SWO Configuration dialog box . . . . .	225
Software (Default breakpoint type setting) . . . . .	155	SWO on the TraceD0 pin (I-jet option) . . . . .	610
Solid Graph (Timeline window context menu) . . . . .	285	SWO prescaler (I-jet option) . . . . .	610
Sort by (Timeline window context menu) . . . . .	424	SWO protocol (I-jet option) . . . . .	608, 610
__sourcePosition (C-SPY system macro) . . . . .	496	SWO trace . . . . .	211
special function registers (SFR) . . . . .		SWO Trace Settings dialog box . . . . .	223
in Registers window . . . . .	187	SWO Trace Settings dialog box (I-jet) . . . . .	223
using as assembler symbols . . . . .	99	Symbolic Memory window . . . . .	179
Stack window . . . . .	182	Symbols window . . . . .	121
		symbols, in C-SPY expressions . . . . .	98
		__system1 (C-SPY system macro) . . . . .	498

\_\_system2 (C-SPY system macro) . . . . . 499  
 \_\_system3 (C-SPY system macro) . . . . . 500

## T

Target number (Explicit probe configuration setting) 599, 607  
 Target power (I-jet option) . . . . . 604  
 Target power (ST-LINK option) . . . . . 620  
 target system, definition of . . . . . 43  
 Target with multiple CPUs  
 (Explicit probe configuration setting) . . . . . 599, 607  
 \_\_targetDebuggerVersion (C-SPY system macro) . . . . . 500  
 TCP/IP address or hostname (GDB Server option) . . . . . 601  
 Terminal IO Log Files (Terminal IO Log Files option) . . . . . 91  
 Terminal I/O Log Files dialog box . . . . . 91  
 Terminal I/O window . . . . . 81, 90  
 Text search (Find in Trace option) . . . . . 254  
 Third-Party Driver (debugger options) . . . . . 630  
 TI emulation package installation path (TI XDS option) . . . . . 628  
 TI MSP-FET menu (C-SPY driver) . . . . . 653  
 TI Stellaris menu (C-SPY driver) . . . . . 655  
 TI XDS menu (C-SPY driver) . . . . . 656  
 Time Axis Unit  
 (Timeline window context menu) . . . . . 281, 285, 289, 347, 425  
 time interval, in Timeline window . . . . . 299  
 Time Stamps (Force setting) . . . . . 223  
 Timeline window . . . . . 422  
 Timeline window (Call Stack graph) . . . . . 277  
 Timeline window (Data Log graph) . . . . . 282  
 Timeline window (Events graph) . . . . . 286  
 Timeline window (State Log graph) . . . . . 344  
 --timeout (C-SPY command line option) . . . . . 572  
 timer interrupt, example . . . . . 406  
 timestamps in SWO trace . . . . . 223  
 Toggle Breakpoint (Code)  
 (Disassembly window context menu) . . . . . 86  
 Toggle Breakpoint (Log)  
 (Disassembly window context menu) . . . . . 86  
 Toggle Breakpoint (Trace Start)  
 (Disassembly window context menu) . . . . . 86

Toggle Breakpoint (Trace Stop)  
 (Disassembly window context menu) . . . . . 86  
 Toggle source (Trace toolbar) . . . . . 230  
 \_\_toLower (C-SPY system macro) . . . . . 501  
 tools icon, in this guide . . . . . 34  
 \_\_toString (C-SPY system macro) . . . . . 501  
 \_\_toUpper (C-SPY system macro) . . . . . 502  
 trace . . . . . 209, 257  
 Trace Filter breakpoints dialog box (I-jet) . . . . . 245  
 Trace Filter breakpoints dialog box (J-Link) . . . . . 251  
 Trace Save dialog box . . . . . 256  
 Trace Start breakpoints dialog box (J-Link/J-Trace) . . . . . 246  
 Trace Start breakpoints dialog box  
 (I-jet and CMSIS-DAP) . . . . . 241  
 Trace Start Trigger breakpoint dialog box . . . . . 239  
 trace start/stop trigger breakpoints, overview . . . . . 126  
 Trace Stop breakpoints dialog box (J-Link/J-Trace) . . . . . 249  
 Trace Stop breakpoints dialog box  
 (I-jet and CMSIS-DAP) . . . . . 243  
 Trace Stop Trigger breakpoint dialog box . . . . . 240  
 Trace window . . . . . 229  
 trace (calls), profiling source . . . . . 294  
 trace (flat), profiling source . . . . . 294  
 trademarks . . . . . 2  
 Trigger at (Trace Start option) . . . . . 242, 244, 246–247  
 Trigger at (Trace Stop option) . . . . . 249  
 Trigger range (Data breakpoints option) . . . . . 149  
 Trigger range (Data Log breakpoints option) . . . . . 153  
 Trigger range (Trace Start option) . . . . . 243, 245, 247, 250, 252  
 typographic conventions . . . . . 33

## U

Unavailable, C-SPY message . . . . . 101  
 unhandled cases in switch statements, detecting . . . . . 360  
 \_\_unloadImage (C-SPY system macro) . . . . . 502  
 Use command line options (debugger option) . . . . . 591  
 Use Extra Images (debugger option) . . . . . 587  
 Use flash loader (debugger option) . . . . . 586  
 Use manual ranges (Memory Access Setup option) . . . . . 197

Use ranges based on (Memory Access Setup option) . . . .	196
Used ranges (Memory Configuration option) . . . . .	202
user application, definition of . . . . .	43
User (Mode setting) . . . . .	145
using checked variant . . . . .	351

## V

Value (Address setting) . . . . .	144
Value (Data setting) . . . . .	145
Value (Fill option) . . . . .	178
Value (Match data setting) . . . . .	150, 242, 244, 248, 250, 253
__var (C-SPY macro keyword) . . . . .	435
variables	
effects of optimizations . . . . .	101
in C-SPY expressions . . . . .	99
information, limitation on . . . . .	101
variance (interrupt property), definition of . . . . .	403
Variance % (Interrupt Configuration option) . . . . .	411
Vector Catch dialog box . . . . .	157
Vector Catch (CMSIS-DAP menu) . . . . .	638
Vector Catch (I-jet menu) . . . . .	645
Vector Catch (J-Link menu) . . . . .	647
Vector Catch (ST-Link menu) . . . . .	651
Vector Catch (TI Stellaris menu) . . . . .	655
Vector Catch (TI XDS menu) . . . . .	657
Verify download (debugger option) . . . . .	586
version number	
of this guide . . . . .	2
Viewing Range dialog box . . . . .	290
Viewing Range	
(Timeline window context menu) . . . . .	284, 288, 346
virtual platform . . . . .	594
Visual State, C-SPY plugin module for . . . . .	45

## W

waiting for device, power consumption during . . . . .	324
__wallTime_ms (C-SPY system macro) . . . . .	503

warnings icon, in this guide . . . . .	34
Watch window . . . . .	109
using . . . . .	97
web sites, recommended . . . . .	32
while (macro statement) . . . . .	437
windows, specific to C-SPY . . . . .	71
Word (Data setting) . . . . .	145
Write (Access Type setting) . . . . .	144
__writeAPReg (C-SPY system macro) . . . . .	504
__writeDPRReg (C-SPY system macro) . . . . .	505
__writeFile (C-SPY system macro) . . . . .	505
__writeFileByte (C-SPY system macro) . . . . .	506
__writeMemoryBuffer (C-SPY system macro) . . . . .	448
__writeMemoryByte (C-SPY system macro) . . . . .	506
__writeMemory8 (C-SPY system macro) . . . . .	506
__writeMemory16 (C-SPY system macro) . . . . .	506
__writeMemory32 (C-SPY system macro) . . . . .	507
__writeMemory64 (C-SPY system macro) . . . . .	508

## X

--xds_board_file (C-SPY command line option) . . . . .	572
--xds_reset_strategy (C-SPY command line option) . . . . .	573
--xds_rootdir (C-SPY command line option) . . . . .	574

## Z

zone	
in C-SPY . . . . .	165
part of an absolute address . . . . .	160
Zone (Edit SFR option) . . . . .	195
Zoom	
(Timeline window context menu) . . . . .	279, 284, 288, 346, 424

## Symbols

__abortLaunch (C-SPY system macro) . . . . .	448
__argCount (C-SPY system macro) . . . . .	444
__as_get_base (operator) . . . . .	385



- \_\_as\_get\_bound (operator) . . . . . 385
- \_\_as\_make\_bounds (operator) . . . . . 386
- \_\_bytes2Word16 (C-SPY system macro) . . . . . 444
- \_\_bytes2Word32 (C-SPY system macro) . . . . . 444
- \_\_cancelAllInterrupts (C-SPY system macro) . . . . . 449
- \_\_cancelInterrupt (C-SPY system macro) . . . . . 449
- \_\_clearBreak (C-SPY system macro) . . . . . 450
- \_\_closeFile (C-SPY system macro) . . . . . 450
- \_\_delay (C-SPY system macro) . . . . . 450
- \_\_disableInterrupts (C-SPY system macro) . . . . . 451
- \_\_driverType (C-SPY system macro) . . . . . 451
- \_\_emulatorSpeed (C-SPY system macro) . . . . . 452
- \_\_emulatorStatusCheckOnRead (C-SPY system macro) . . . . . 453
- \_\_enableInterrupts (C-SPY system macro) . . . . . 453
- \_\_evaluate (C-SPY system macro) . . . . . 454
- \_\_expandVar (C-SPY system macro) . . . . . 454
- \_\_fillMemory8 (C-SPY system macro) . . . . . 455
- \_\_fillMemory16 (C-SPY system macro) . . . . . 456
- \_\_fillMemory32 (C-SPY system macro) . . . . . 457
- \_\_fillMemory64 (C-SPY system macro) . . . . . 458
- \_\_fmessage (C-SPY macro keyword) . . . . . 438
- \_\_gdbserver\_exec\_command (C-SPY system macro) . . . . . 459
- \_\_getArg (C-SPY system macro) . . . . . 445
- \_\_getNumberOfCores (C-SPY system macro) . . . . . 459
- \_\_getSelectedCore (C-SPY system macro) . . . . . 459
- \_\_getTracePortSize (C-SPY system macro) . . . . . 460
- \_\_hasDAPRegs (C-SPY system macro) . . . . . 461
- \_\_hwJetResetWithStrategy (C-SPY system macro) . . . . . 461
- \_\_hwReset (C-SPY system macro) . . . . . 462
- \_\_hwResetRunToBp (C-SPY system macro) . . . . . 462
- \_\_hwResetWithStrategy (C-SPY system macro) . . . . . 464
- \_\_hwRunToBreakpoint (C-SPY system macro) . . . . . 464
- \_\_isBatchMode (C-SPY system macro) . . . . . 465
- \_\_isMacroSymbolDefined (C-SPY system macro) . . . . . 466
- \_\_jlinkExecCommand (C-SPY system macro) . . . . . 466
- \_\_jlinkExecMacro (C-SPY system macro) . . . . . 467
- \_\_jtagCommand (C-SPY system macro) . . . . . 467
- \_\_jtagCP15IsPresent (C-SPY system macro) . . . . . 468
- \_\_jtagCP15ReadReg (C-SPY system macro) . . . . . 468
- \_\_jtagCP15WriteReg (C-SPY system macro) . . . . . 468
- \_\_jtagData (C-SPY system macro) . . . . . 469
- \_\_jtagRawRead (C-SPY system macro) . . . . . 469
- \_\_jtagRawSync (C-SPY system macro) . . . . . 470
- \_\_jtagRawWrite (C-SPY system macro) . . . . . 471
- \_\_jtagResetTRST (C-SPY system macro) . . . . . 472
- \_\_loadImage (C-SPY system macro) . . . . . 472
- \_\_makeString (C-SPY system macro) . . . . . 446
- \_\_memoryRestore (C-SPY system macro) . . . . . 473
- \_\_memorySave (C-SPY system macro) . . . . . 474
- \_\_message (C-SPY macro keyword) . . . . . 438
- \_\_messageBoxYesCancel (C-SPY system macro) . . . . . 475
- \_\_messageBoxYesNo (C-SPY system macro) . . . . . 476
- \_\_openFile (C-SPY system macro) . . . . . 476
- \_\_orderInterrupt (C-SPY system macro) . . . . . 477
- \_\_param (C-SPY macro keyword) . . . . . 436
- \_\_popSimulatorInterruptExecutingStack  
(C-SPY system macro) . . . . . 478
- \_\_probeType (C-SPY system macro) . . . . . 479
- \_\_readAPReg (C-SPY system macro) . . . . . 480
- \_\_readDPRReg (C-SPY system macro) . . . . . 480
- \_\_readFile (C-SPY system macro) . . . . . 481
- \_\_readFileByte (C-SPY system macro) . . . . . 481
- \_\_readMemoryBuffer (C-SPY system macro) . . . . . 447
- \_\_readMemoryByte (C-SPY system macro) . . . . . 482
- \_\_readMemory8 (C-SPY system macro) . . . . . 482
- \_\_readMemory16 (C-SPY system macro) . . . . . 482
- \_\_readMemory32 (C-SPY system macro) . . . . . 483
- \_\_readMemory64 (C-SPY system macro) . . . . . 483
- \_\_registerMacroFile (C-SPY system macro) . . . . . 484
- \_\_resetFile (C-SPY system macro) . . . . . 484
- \_\_restoreSoftwareBreakpoints (C-SPY system macro) . . . . . 484
- \_\_selectCore (C-SPY system macro) . . . . . 485
- \_\_setCodeBreak (C-SPY system macro) . . . . . 486
- \_\_setDataBreak (C-SPY system macro) . . . . . 487
- \_\_setDataLogBreak (C-SPY system macro) . . . . . 489
- \_\_setLogBreak (C-SPY system macro) . . . . . 490
- \_\_setSimBreak (C-SPY system macro) . . . . . 492
- \_\_setTraceStartBreak (C-SPY system macro) . . . . . 493
- \_\_setTraceStopBreak (C-SPY system macro) . . . . . 495

__smessage (C-SPY macro keyword) . . . . .	438	--debug_heap (linker option) . . . . .	381
__sourcePosition (C-SPY system macro) . . . . .	496	--device (C-SPY command line option) . . . . .	532
__strFind (C-SPY system macro) . . . . .	497	--device_macro (C-SPY command line option) . . . . .	532
__subString (C-SPY system macro) . . . . .	497	--disable_interrupts (C-SPY command line option) . . . . .	532
__system1 (C-SPY system macro) . . . . .	498	--download_only (C-SPY command line option) . . . . .	533
__system2 (C-SPY system macro) . . . . .	499	--drv_catch_exceptions (C-SPY command line option) . . . . .	533
__system3 (C-SPY system macro) . . . . .	500	--drv_communication (C-SPY command line option) . . . . .	534
__targetDebuggerVersion (C-SPY system macro) . . . . .	500	--drv_communication_log (C-SPY command line option) . . . . .	538
__toLower (C-SPY system macro) . . . . .	501	--drv_debugger_cache (C-SPY command line option) . . . . .	538
__toString (C-SPY system macro) . . . . .	501	--drv_default_breakpoint (C-SPY command line option) . . . . .	539
__ToUpper (C-SPY system macro) . . . . .	502	--drv_enforce_mem_config (C-SPY command line option) . . . . .	540
__unloadImage (C-SPY system macro) . . . . .	502	--drv_exclude_from_verify (C-SPY command line option) . . . . .	540
__var (C-SPY macro keyword) . . . . .	435	--drv_interface (C-SPY command line option) . . . . .	541
__wallTime_ms (C-SPY system macro) . . . . .	503	--drv_interface_speed (C-SPY command line option) . . . . .	542
__writeAPReg (C-SPY system macro) . . . . .	504	--drv_mem_ap (C-SPY command line option) . . . . .	543
__writeDPReg (C-SPY system macro) . . . . .	505	--drv_reset_to_cpu_start (C-SPY command line option) . . . . .	543
__writeFile (C-SPY system macro) . . . . .	505	--drv_restore_breakpoints (C-SPY command line option) . . . . .	544
__writeFileByte (C-SPY system macro) . . . . .	506	--drv_suppress_download (C-SPY command line option) . . . . .	519
__writeMemoryBuffer (C-SPY system macro) . . . . .	448	--drv_swo_clock_setup (C-SPY command line option) . . . . .	544
__writeMemoryByte (C-SPY system macro) . . . . .	506	--drv_trace_settings (C-SPY command line option) . . . . .	545
__writeMemory8 (C-SPY system macro) . . . . .	506	--drv_vector_table_base (C-SPY command line option) . . . . .	546
__writeMemory16 (C-SPY system macro) . . . . .	506	--drv_verify_download (C-SPY command line option) . . . . .	519
__writeMemory32 (C-SPY system macro) . . . . .	507	--endian (C-SPY command line option) . . . . .	519
__writeMemory64 (C-SPY system macro) . . . . .	508	--flash_loader (C-SPY command line option) . . . . .	547
-f (cspybat option) . . . . .	547	--fpu (C-SPY command line option) . . . . .	520
-p (C-SPY command line option) . . . . .	565	--function_profiling (cspybat option) . . . . .	548
--application_args (C-SPY command line option) . . . . .	527	--gdbserv_exec_command (C-SPY command line option) . . . . .	548
--attach_to_running_target (C-SPY command line option) . . . . .	528	--generate_entries_without_bounds (compiler option) . . . . .	381
--backend (C-SPY command line option) . . . . .	528	--ignore_uninstrumented_pointers (compiler option) . . . . .	381
--BE32 (C-SPY command line option) . . . . .	519	--ignore_uninstrumented_pointers (linker option) . . . . .	382
--BE8 (C-SPY command line option) . . . . .	519	--jet_board_cfg (C-SPY command line option) . . . . .	548
--bounds_table_size (linker option) . . . . .	380	--jet_board_did (C-SPY command line option) . . . . .	549
--code_coverage_file (C-SPY command line option) . . . . .	529		
--cpu (C-SPY command line option) . . . . .	519		
--cycles (C-SPY command line option) . . . . .	529		
--debug_auth_enforce (C-SPY command line option) . . . . .	530		
--debug_auth_settings (C-SPY command line option) . . . . .	530		
--debug_auth_type (C-SPY command line option) . . . . .	531		
--debug_file (cspybat option) . . . . .	531		

- jet\_cpu\_clock (C-SPY command line option) . . . . . 550
  - jet\_disable\_pmu (C-SPY command line option) . . . . . 550
  - jet\_disable\_pmu\_dap (C-SPY command line option) . . . . . 551
  - jet\_ir\_length (C-SPY command line option) . . . . . 551
  - jet\_power\_from\_probe (C-SPY command line option) . . . . . 551
  - jet\_probe (C-SPY command line option) . . . . . 552
  - jet\_script\_file (C-SPY command line option) . . . . . 552
  - jet\_standard\_reset (C-SPY command line option) . . . . . 553
  - jet\_startup\_connection\_timeout  
(C-SPY command line option) . . . . . 554
  - jet\_swo\_on\_d0 (C-SPY command line option) . . . . . 555
  - jet\_swo\_prescaler (C-SPY command line option) . . . . . 555
  - jet\_swo\_protocol (C-SPY command line option) . . . . . 555
  - jet\_tap\_position (C-SPY command line option) . . . . . 556
  - jlink\_dcc\_timeout (C-SPY command line option) . . . . . 556
  - jlink\_device\_select (C-SPY command line option) . . . . . 557
  - jlink\_exec\_command (C-SPY command line option) . . . . . 557
  - jlink\_initial\_speed (C-SPY command line option) . . . . . 558
  - jlink\_ir\_length (C-SPY command line option) . . . . . 558
  - jlink\_reset\_strategy (C-SPY command line option) . . . . . 559
  - jlink\_script\_file (C-SPY command line option) . . . . . 559
  - jlink\_trace\_source (C-SPY command line option) . . . . . 560
  - leave\_target\_running (C-SPY command line option) . . . . . 560
  - lmiftdi\_reset\_strategy (C-SPY command line option) . . . . . 561
  - macro (C-SPY command line option) . . . . . 561
  - macro\_param (C-SPY command line option) . . . . . 562
  - mapu (C-SPY command line option) . . . . . 562
  - mspfet\_erase\_flash (C-SPY command line option) . . . . . 562
  - mspfet\_interface\_speed (C-SPY command line option) . . . . . 563
  - mspfet\_reset\_strategy (C-SPY command line option) . . . . . 563
  - mspfet\_settlingtime (C-SPY command line option) . . . . . 564
  - mspfet\_vccvoltage (C-SPY command line option) . . . . . 564
  - multicore\_nr\_of\_cores (C-SPY command line option) . . . . . 564
  - plugin (C-SPY command line option) . . . . . 565
  - proc\_stack\_xxx (C-SPY command line option) . . . . . 566
  - reset\_style (C-SPY command line option) . . . . . 566
  - rtc\_enable (csybat option) . . . . . 387
  - rtc\_output (csybat option) . . . . . 387
  - rtc\_raw\_to\_txt (csybat option) . . . . . 387
  - rtc\_rules (csybat option) . . . . . 388
  - runtime\_checking (compiler option) . . . . . 382
  - sdm\_debug\_architecture (C-SPY command line option) . . . . . 568
  - sdm\_library (C-SPY command line option) . . . . . 568
  - sdm\_library\_hint (C-SPY command line option) . . . . . 569
  - sdm\_manifest (C-SPY command line option) . . . . . 569
  - semihosting (C-SPY command line option) . . . . . 570
  - silent (C-SPY command line option) . . . . . 570
  - sockets (C-SPY command line option) . . . . . 571
  - stlink\_reset\_strategy (C-SPY command line option) . . . . . 571
  - suppress\_entrypoint\_warning  
(C-SPY command line option) . . . . . 572
  - timeout (C-SPY command line option) . . . . . 572
  - xds\_board\_file (C-SPY command line option) . . . . . 572
  - xds\_reset\_strategy (C-SPY command line option) . . . . . 573
  - xds\_rootdir (C-SPY command line option) . . . . . 574
  - #PC (symbol) in C-SPY macros . . . . . 99, 437
  - #PC32 (symbol) in C-SPY macros . . . . . 99, 437
  - #PC64 (symbol) in C-SPY macros . . . . . 99, 437
- ## Numerics
- 1x Units (Symbolic Memory window context menu) . . . . . 181
  - 32-bit mode
    - definition . . . . . 45
  - 64-bit mode
    - definition . . . . . 45
  - 8x Units (Memory window context menu) . . . . . 174